

Construction Stormwater General Permit (CSWGP)

Stormwater Pollution Prevention Plan (SWPPP)

for

Raising Cane's Restaurant # C1360

Prepared for:

City of Puyallup

Development & Permitting Services

333 S Meridian

Puyallup, WA 98371

Permittee / Owner	Developer	Operator / Contractor
Raising Cane's	Raising Cane's	TBD

4110 S Meridian St

Puyallup, WA 98373

Certified Erosion and Sediment Control Lead (CESCL)

Name	Organization	Contact Phone Number
TBD	TBD	TBD

SWPPP Prepared By

Name	Organization	Contact Phone Number
Liz Willmot	Kimley-Horn	(206) 677-8610

SWPPP Preparation Date

03/09/2026

Project Construction Dates

Activity / Phase	Start Date	End Date
Construction	Winter 2027	Summer 2027

Table of Contents

Project Information (1.0)	5
Existing Conditions (1.1)	5
Proposed Construction Activities (1.2)	6
Construction Stormwater Best Management Practices (BMPs) (2.0).....	8
The 13 Elements (2.1)	8
Element 1: Preserve Vegetation / Mark Clearing Limits (2.1.1)	8
Element 2: Establish Construction Access (2.1.2)	9
Element 3: Control Flow Rates (2.1.3)	10
Element 4: Install Sediment Controls (2.1.4)	11
Element 5: Stabilize Soils (2.1.5)	12
Element 6: Protect Slopes (2.1.6).....	14
Element 7: Protect Drain Inlets (2.1.7)	15
Element 8: Stabilize Channels and Outlets (2.1.8).....	16
Element 9: Control Pollutants (2.1.9)	17
Element 10: Control Dewatering (2.1.10).....	20
Element 11: Maintain BMPs (2.1.11)	21
Element 12: Manage the Project (2.1.12).....	22
Element 13: Protect Low Impact Development (LID) BMPs (2.1.13).....	25
Pollution Prevention Team (3.0).....	26
Monitoring and Sampling Requirements (4.0)	27
Site Inspection (4.1)	27
Stormwater Quality Sampling (4.2)	27
Turbidity Sampling (4.2.1).....	27
pH Sampling (4.2.2).....	29
Discharges to 303(d) or Total Maximum Daily Load (TMDL) Waterbodies (5.0).....	30
303(d) Listed Waterbodies (5.1)	30
TMDL Waterbodies (5.2).....	30
Reporting and Record Keeping (6.0).....	31
Record Keeping (6.1).....	31
Site Log Book (6.1.1)	31

Records Retention (6.1.2)	31
Updating the SWPPP (6.1.3)	31
Reporting (6.2)	32
Discharge Monitoring Reports (6.2.1).....	32
Notification of Noncompliance (6.2.2).....	32

List of Tables

Table 1 – Summary of Site Pollutant Constituents	6
Table 2 – Pollutants.....	17
Table 3 – pH-Modifying Sources	19
Table 4 – Dewatering BMPs	20
Table 5 – Management	22
Table 6 – BMP Implementation Schedule.....	23
Table 7 – Team Information.....	26
Table 8 – Turbidity Sampling Method.....	27
Table 9 – pH Sampling Method.....	29

List of Appendices

- A. Site Map
- B. BMP Details
- C. Correspondence
- D. Site Inspection Form
- E. Construction Stormwater General Permit (CSWGP)
- F. 303(d) List Waterbodies / TMDL Waterbodies Information
- G. Contaminated Site Information
- H. Engineering Calculations

List of Acronyms and Abbreviations

Acronym / Abbreviation	Explanation
303(d)	Section of the Clean Water Act pertaining to Impaired Waterbodies
BFO	Bellingham Field Office of the Department of Ecology
BMP(s)	Best Management Practice(s)
CESCL	Certified Erosion and Sediment Control Lead
CO₂	Carbon Dioxide
CRO	Central Regional Office of the Department of Ecology
CSWGP	Construction Stormwater General Permit
CWA	Clean Water Act
DMR	Discharge Monitoring Report
DO	Dissolved Oxygen
Ecology	Washington State Department of Ecology
EPA	United States Environmental Protection Agency
ERO	Eastern Regional Office of the Department of Ecology
ERTS	Environmental Report Tracking System
ESC	Erosion and Sediment Control
GULD	General Use Level Designation
NPDES	National Pollutant Discharge Elimination System
NTU	Nephelometric Turbidity Units
NWRO	Northwest Regional Office of the Department of Ecology
pH	Power of Hydrogen
RCW	Revised Code of Washington
SPCC	Spill Prevention, Control, and Countermeasure
su	Standard Units
SWMMEW	Stormwater Management Manual for Eastern Washington
SWMMWW	Stormwater Management Manual for Western Washington
SWPPP	Stormwater Pollution Prevention Plan
TESC	Temporary Erosion and Sediment Control
SWRO	Southwest Regional Office of the Department of Ecology
TMDL	Total Maximum Daily Load
VFO	Vancouver Field Office of the Department of Ecology
WAC	Washington Administrative Code
WSDOT	Washington Department of Transportation
WWHM	Western Washington Hydrology Model

Project Information (1.0)

Project/Site Name: Raising Cane's Restaurant # C1360

Street/Location: 4110 S Meridian Street

City: Puyallup State: WA Zip code: 98373

Subdivision: Not specified

Receiving waterbody: Infiltrating into native soils onsite, Unnamed Perennial Stream west of project site tributary to

Existing Conditions (1.1)

Total acreage (including support activities such as off-site equipment staging yards, material storage areas, borrow areas).

Total acreage: 1.07 ac.

Disturbed acreage: 1.07 ac.

Existing structures: The existing site consists of one commercial building.

Landscape topography: The site has one commercial building with associated parking and drive aisle areas. The existing average slope is approximately 4% across the site, with a drop of 8 feet from west to east.

Drainage patterns: The site drains to existing catch basins onsite and existing neighborhood properties connected to the existing stormwater system with open natural grass-lined channels, that eventually outfalls into an unnamed perennial stream west of the site. The stream is publicly owned by the City of Puyallup Public Works.

Existing Vegetation: The existing site has one commercial building, with associated asphalt pavement parking and drive aisles. There is landscaping around the perimeter of the site. Existing site soil has been classified as Everett very gravelly sand loam, which is considered hydrologic soil group A.

Critical Areas: This project is located within Zone X, meaning that it is outside the bounds of the 100- and 500-year floodplain.

List of known impairments for 303(d) listed or Total Maximum Daily Load (TMDL) for the receiving waterbody: N/A

No suspected or known contaminants, refer to the Phase I Environmental Site Assessment prepared by Terracon Consultants, Inc. on March 19th, 2025.

Table 1 – Summary of Site Pollutant Constituents

Constituent (Pollutant)	Location	Depth	Concentration
N/A	N/A	N/A	N/A

Proposed Construction Activities (1.2)

Description of site development (example: subdivision):

This project proposes the development of a new 2,868 SF gross area restaurant with outdoor seating, two drive-thru lanes with canopies, and associated infrastructure in the City of Puyallup, WA.

Description of construction activities (example: site preparation, demolition, excavation):

Clearing and grubbing to install the appropriate temporary erosion and sediment control measures. The site will be regraded for roads, building foundation, temporary access points, and utility location. Install utility lines from existing utilities to the building structure. Install pavement on the majority of the site for roads and parking with landscaping around the perimeter of the site. A below grade water quality vault and gravel infiltration trench are proposed on site, as shown in the site plan in Appendix A.

Description of site drainage including flow from and onto adjacent properties. Must be consistent with Site Map in Appendix A:

The proposed improvements are delineated into one (1) drainage basin to capture stormwater runoff onsite. Onsite stormwater runoff is captured with proposed catch basins, and routed to a water quality vault before entering a gravel infiltration trench where the stormwater runoff will infiltrate to native soils. During storm events exceeding the 100-year storm, emergency overflow will leave the site via an overflow riser and outfall into the municipal along S Meridian Street for further conveyance, eventually out falling into unnamed perennial stream west of project site. The permanent gravel infiltration trench and below grade water quality vault are shown in the site plan in Appendix A.

Description of final stabilization (example: extent of revegetation, paving, landscaping):

Final stabilization of the proposed site will include new pavement over the majority of the disturbed areas, one onsite gravel infiltration trench, and stabilizing seeding, sodding, and landscaping on the remainder of the site.

Contaminated Site Information:

Proposed activities regarding contaminated soils or groundwater (example: on-site treatment system, authorized sanitary sewer discharge):

Construction activities will be addressed with erosion control measures and no contamination is anticipated.

An underground water quality vault will be placed upstream of the underground infiltration facility to treat water run-off before infiltrating into native soils. More than 300 trips are expected per day, meaning oil control will be required. Oil control is included in the proposed water quality vault.

Construction Stormwater Best Management Practices (BMPs) (2.0)

The SWPPP is a living document reflecting current conditions and changes throughout the life of the project. These changes may be informal (i.e. hand-written notes and deletions). Update the SWPPP when the CESCL has noted a deficiency in BMPs or deviation from original design.

The 13 Elements (2.1)

Element 1: Preserve Vegetation / Mark Clearing Limits (2.1.1)

To protect adjacent properties and to reduce the area of soil exposed to construction, the limits of construction will be clearly marked before land-disturbing activities begin.

List and describe BMPs:

- Silt Fence (BMP C233)
 - Silt fence will be used where delineated on the Temporary Erosion and Sediment Control (TESC) Plan to protect areas that should not be disturbed and to control on-site sedimentation throughout the construction process.

Installation Schedules: All BMPs to preserve vegetation and mark clearing limits are to be installed prior to clearing, demolition, and grading construction activities.

Inspection and Maintenance plan: See Appendix B

Responsible Staff: Certified Erosion and Sediment Control Lead

Element 2: Establish Construction Access (2.1.2)

Construction access and activities occurring on unpaved areas shall be minimized, where necessary, access points shall be stabilized to minimize the tracking of sediment onto public roads off-site. Street sweeping, street cleaning, and wheel wash shall be employed where necessary to prevent sediment from entering state waters. All wheel wash wastewater shall be controlled onsite and cannot be discharged into State waters.

List and describe BMPs:

- Stabilized Construction Access (BMP C105)
 - The stabilized construction access will be constructed at each entrance/exit to the site. Vehicles and construction equipment will be required to travel the full length of the stabilized construction access to reduce the amount of sediment leaving the site.

Installation Schedules: To be completed by Contractor and CESCL

Inspection and Maintenance plan: See Appendix B

Responsible Staff: Certified Erosion and Sediment Control Lead

Element 3: Control Flow Rates (2.1.3)

All stormwater infiltrates onsite and there will be no stormwater discharging from the project site. Construction of stormwater retention facilities must be done as one of the first steps in grading. A gravel infiltration trench will be constructed on the south side of the site.

Will you construct stormwater retention and/or detention facilities?

Yes No

Will you use permanent infiltration ponds or other low impact development (example: rain gardens, bio-retention, porous pavement) to control flow during construction?

Yes No

List and describe BMPs:

- Sediment Trap (BMP C240)
 - A sediment trap will be installed where delineated in the TESC plan to collect and store sediment during construction.
- Interceptor Dike and Swale (BMP C200)
 - An Interceptor Swale will be installed within the permanent facility footprint where delineated in the TESC plan to collect water and direct it towards the Sediment Trap

Installation Schedules: To be completed by Contractor and CESCL

Inspection and Maintenance plan: See Appendix B

Responsible Staff: Certified Erosion and Sediment Control Lead

Element 4: Install Sediment Controls (2.1.4)

Stormwater runoff from disturbed areas shall pass through appropriate sediment removal BMPs. Construct sediment control BMPs as one of the first steps of grading. Any damage to these BMPs will be repaired immediately. Stabilized areas should be inspected regularly, especially after large storm events.

List and describe BMPs:

- Silt Fence (BMP C233)
 - During site development, silt fence shall be installed along the perimeter of the site to prevent sedimentation from exiting the site by providing a temporary physical barrier.
- Sediment Trap (BMP C240)
 - A sediment trap will be installed where delineated in the TESC plan to collect and store sediment during construction.

Installation Schedules: To be completed by Contractor and CESCL

Inspection and Maintenance plan: See Appendix B

Responsible Staff: Certified Erosion and Sediment Control Lead

Element 5: Stabilize Soils (2.1.5)

All exposed and unworked soils shall be stabilized by the application of effective BMPs that protect the soil from the erosive forces of raindrops, flowing water, and wind throughout the life of the project. The project site is West of the Cascade Mountains Crest. Reference the table for the number of days soils can be left exposed during the dry and wet seasons. In general, the cut and fill slopes will be stabilized as soon as possible, and soil stockpiles will be temporarily covered with plastic sheeting. All stockpiled materials shall be stabilized from erosion and be located away from storm drain inlets and drainage channels, where possible.

West of the Cascade Mountains Crest

Season	Dates	Number of Days Soils Can be Left Exposed
During the Dry Season	May 1 – September 30	7 days
During the Wet Season	October 1 – April 30	2 days

Soils must be stabilized at the end of the shift before a holiday or weekend if needed based on the weather forecast.

Anticipated project dates: Start date: Winter 2027 End date: Summer 2027

Will you construct during the wet season?

Yes No

List and describe BMPs:

- Temporary and Permanent Seeding (BMP C120)
 - Following final grading activity, permanent seeding shall be placed on exposed soil to reduce erosion by stabilizing exposed soils.
- Mulching (BMP C121)
 - Provide immediate temporary protection of soils from erosion by mulching. Mulching soils also promotes the plants from the seeding of BMP C120E.
- Nets and Blankets (BMP C122)
 - Erosion control nets and blankets prevent erosion and hold seed (from BMP C120) and mulch (from C121) in place.
- Plastic Covering (BMP C123)
 - Cover cut and fill slopes and stockpiles for short periods (less than 6 months) to provide immediate erosion protection.
- Dust Control (BMP C140)
 - During the grading phase of construction, dust control will prevent wind erosion of soils.

Installation Schedules: To be completed by Contractor and CESCL

Inspection and Maintenance plan: See Appendix B

Responsible Staff: Certified Erosion and Sediment Control Lead

Element 6: Protect Slopes (2.1.6)

All cut and fill slopes will be designed, constructed, and protected in a manner that minimizes erosion. No steep slopes will be present during construction.

Will steep slopes be present at the site during construction?

Yes No

List and describe BMPs:

- Temporary and Permanent Seeding (BMP C120)
 - Following final grading activity, permanent seeding shall be placed on exposed soil to reduce erosion by stabilizing exposed soils.
- Mulching (BMP C121)
 - Provide immediate temporary protection of soils from erosion by mulching. Mulching soils also promotes the plants from the seeding of BMP C120.
- Plastic Covering (BMP C123)
 - Cover cut and fill slopes and stockpiles for short periods (less than 6 months) to provide immediate erosion protection.

Installation Schedules: To be completed by Contractor and CESCL

Inspection and Maintenance plan: See Appendix B

Responsible Staff: Certified Erosion and Sediment Control Lead

Element 7: Protect Drain Inlets (2.1.7)

All existing and proposed storm drain inlets and culverts made operable during construction shall be protected to prevent sedimentation from entering the stormwater conveyance system. The priority is to keep all access roads clean of sediment and keep street wash and wheel wash water separate from entering storm drains until treatment can be provided. Inlet protection will be implemented for all drainage inlets and culverts on or near the project site.

Inlet protection may function well for coarse sediment but is less effective in filtering finer particles and dissolved constituents. Inlet protection is the last component of a treatment train and protection of drain inlets include additional sediment and erosion control measures.

List and describe BMPs:

- Sediment Trap (BMP C240)
 - A sediment trap will be installed where delineated in the TESC plan to collect and store sediment during construction.
- Inlet Protection (BMP C220)
 - Prior to construction, storm drain inlet protection will be installed on all catch basins in the roadways along the frontage of any areas receiving stormwater from construction activities within the permitted area. Additionally, inlet protection will be installed as the proposed storm drain system is installed onsite.

Installation Schedules: To be completed by Contractor and CESCL

Inspection and Maintenance plan: See Appendix B

- Inlet protection devices will be cleaned (or removed and replaced), when sediment has filled the device by one third (1/3) or as specified by the manufacturer.
- Inlets will be inspected weekly at a minimum and daily during storm events.

Responsible Staff: Certified Erosion and Sediment Control Lead

Element 8: Stabilize Channels and Outlets (2.1.8)

West of the Cascade Mountains Crest

On-site conveyance channels must handle the peak 10-minute flow rate from a Type 1A, 10-year, 24-hour frequency storm for the developed condition. Alternatively, the 10-year, 1-hour flow rate predicted by an approved continuous runoff model, increased by a factor of 1.6, may be used.

The hydrologic analysis must use the existing land cover condition for predicting flow rates from tributary areas outside the project limits.

For tributary areas on the project site, the analysis must use the temporary or permanent project land cover condition, whichever will produce the highest flow rates.

If using the WWHM to predict flows, bare soil areas should be modeled as “landscaped area”.

Provide stabilization, including armoring material, adequate to prevent erosion of outlets, adjacent stream banks, slopes, and downstream reaches, will be installed at the outlets of all conveyance systems.

List and describe BMPs:

No additional BMPs shall be installed to address Element 8. No onsite channels or outlets leading outside of the site because all water infiltrates onsite. During major storm events, discharge will route through an emergency overflow standpipe to existing offsite stormwater infrastructure which outflows to an unnamed Perennial stream west of the site.

Installation Schedules: N/A

Inspection and Maintenance plan: N/A

Responsible Staff: N/A

Element 9: Control Pollutants (2.1.9)

All pollutants, including waste materials and demolition debris, that occur onsite shall be handled and disposed of in a manner to not contaminate stormwater. Preventative measures will be taken to keep the site clean and well organized.

The following pollutants are anticipated to be present on-site:

Table 2 – Pollutants

Pollutant (and source, if applicable)
Dust and Debris
Petroleum Products
Fertilizers and Pesticides
Concrete

List and describe BMPs:

- Concrete Handling (BMP C151)
 - Concrete handling measures will be implemented to prevent process water and slurry, which contain fine particles and have a high pH from concrete work, from discharging into stormwater and reaching waters of the State.
- Sawcutting and Surfacing Pollution Prevention (BMP C152)
 - Sawcutting and surfacing pollution prevention measures will be implemented to prevent process water and slurry, containing fine particles and high pH from sawcutting and surfacing operations, from discharging into stormwater and reaching waters of the State.
- Material Delivery, Storage, and Containment (BMP C153)
 - Any chemicals, such as fertilizers and pesticides, shall have cover, containment, and protection provided on site per Material Delivery measures to prevent, reduce, or eliminate the discharge of pollutants into receiving waters.
- Concrete Washout Area (BMP C154)
 - Provide a designated concrete washout area to prevent and reduce the discharge of pollutants from concrete waste.
- Dust Control (BMP C140)
 - Dust control will be installed to prevent wind transport of dust and debris from disturbed soil surfaces onto roadways, into drainage systems, and into receiving waters during grading and construction activities.
- Other BMPs will be administrated as necessary to address any additional pollutant sources on site which may include, but are not limited to, the following:
 - Fire hydrant and watermain flushing following pressure testing and purification
 - Cleaning foundation panels following concrete pours and/or slurry mixes from the spoils of the concrete truck
 - Flushing of newly installed irrigation systems

- Washing of pavement for stripping
- Construction workers washing tools following installation

Installation Schedules: To be completed by Contractor and CESCL

Inspection and Maintenance plan: See Appendix B

Responsible Staff: Certified Erosion and Sediment Control Lead

Will maintenance, fueling, and/or repair of heavy equipment and vehicles occur on-site?

Yes No

List and describe BMPs:

- Material Delivery, Storage, and Containment (BMP C153)
 - Any chemicals shall have cover, containment, and protection provided on site per Material Delivery measures to prevent, reduce, or eliminate the discharge of pollutants into receiving waters.
- All vehicles, equipment and petroleum product storage/dispensing areas will be inspected regularly to detect any leaks or spills and to identify maintenance needs to prevent leaks or spills.
- On-site fueling tanks and petroleum product storage containers shall include secondary containment.
- Spill prevention measures, such as drip pans, will be used when conducting maintenance and/or repair of vehicles or equipment.
- In order to perform emergency repairs on site, temporary plastic will be placed beneath the vehicle and over it as well if precipitation occurs.

Installation Schedules: To be completed by Contractor and CESCL

Inspection and Maintenance plan: See Appendix B

Responsible Staff: Certified Erosion and Sediment Control Lead

Will wheel wash or tire bath system BMPs be used during construction?

Yes **No**

Will pH-modifying sources be present on-site?

Yes No If yes, check the source(s).

Table 3 – pH-Modifying Sources

	None
	Bulk cement
	Cement kiln dust
	Fly ash
	Other cementitious materials
✓	New concrete washing or curing waters
✓	Waste streams generated from concrete grinding and sawing
✓	Exposed aggregate processes
	Dewatering concrete vaults
✓	Concrete pumping and mixer washout waters
	Recycled concrete
	Other (i.e. calcium lignosulfate) [please describe]

Washdown from any concrete trucks, chutes, pumps, internals, tools, or surfaces shall be washed out only into formed areas awaiting installation of concrete or asphalt. Unused concrete remaining in the truck and pump shall be returned to the originating batch plant for recycling. When no formed areas are available, wash water and leftover product shall be contained in a lined container and not disposed of in a manner that violates the respective groundwater or surface water standards. Slurry and cuttings shall be vacuumed during operations, shall not remain on permanent concrete or asphalt overnight, and shall not drain to any existing or proposed stormwater conveyance system.

List and describe BMPs:

- Concrete Handling (BMP C151)
 - Concrete handling measures will be implemented to prevent process water and slurry, which contain fine particles and have a high pH from concrete work, from discharging into stormwater and reaching waters of the State.
- Sawcutting and Surfacing Pollution Prevention (BMP C152)
 - Sawcutting and surfacing pollution prevention measures will be implemented to prevent process water and slurry, containing fine particles and high pH from sawcutting and surfacing operations, from discharging into stormwater and reaching waters of the State.
- Concrete Washout Area (BMP C154)
 - Provide a designated concrete washout area to prevent and reduce the discharge of pollutants from concrete waste.

Installation Schedules: To be completed by Contractor and CESCL

Inspection and Maintenance plan: See Appendix B

Responsible Staff: Certified Erosion and Sediment Control Lead

Concrete trucks must not be washed out onto the ground, or into storm drains, open ditches, streets, or streams. Excess concrete must not be dumped on-site, except in designated concrete washout areas with appropriate BMPs installed.

Element 10: Control Dewatering (2.1.10)

One (1) gravel infiltration trench are proposed onsite for permanent infiltration whereas a temporary sediment control basin will provide adequate infiltration in the construction phase of the project.

Table 4 – Dewatering BMPs

✓	Infiltration
	Transport off-site in a vehicle (vacuum truck for legal disposal)
	Ecology-approved on-site chemical treatment or other suitable treatment technologies
	Sanitary or combined sewer discharge with local sewer district approval (last resort)
	Use of sedimentation bag with discharge to ditch or swale (small volumes of localized dewatering)

List and describe BMPs:

- Sediment Trap (BMP C240)
 - A sediment trap will be installed within the permanent facility footprint where delineated in the TESC plan to collect and store sediment during construction
- Installation Schedules: To be completed by Contractor and CESCL
- Inspection and Maintenance plan: See Appendix B
- Responsible Staff: Certified Erosion and Sediment Control Lead

Element 11: Maintain BMPs (2.1.11)

All temporary and permanent Erosion and Sediment Control (ESC) BMPs shall be maintained and repaired as needed to ensure continued performance of their intended function.

Maintenance and repair shall be conducted in accordance with each particular BMP specification (see *Volume II of the SWMMWW* or *Chapter 7 of the SWMMEW*).

Visual monitoring of all BMPs installed at the site will be conducted at least once every calendar week and within 24 hours of any stormwater or non-stormwater discharge from the site. If the site becomes inactive and is temporarily stabilized, the inspection frequency may be reduced to once every calendar month.

All temporary ESC BMPs shall be removed within 30 days after final site stabilization is achieved or after the temporary BMPs are no longer needed.

Trapped sediment shall be stabilized on-site or removed. Disturbed soil resulting from removal of either BMPs or vegetation shall be permanently stabilized.

Additionally, protection must be provided for all BMPs installed for the permanent control of stormwater from sediment and compaction. BMPs that are to remain in place following completion of construction shall be examined and restored to full operating condition. If sediment enters these BMPs during construction, the sediment shall be removed and the facility shall be returned to conditions specified in the construction documents.

Element 12: Manage the Project (2.1.12)

The project will be managed based on the following principles:

- Projects will be phased to the maximum extent practicable and seasonal work limitations will be taken into account.
- Inspection and monitoring:
 - Inspection, maintenance and repair of all BMPs will occur as needed to ensure performance of their intended function.
 - Site inspections and monitoring will be conducted in accordance with Special Condition S4 of the CSWGP. Sampling locations are indicated on the [Site Map](#). Sampling station(s) are located in accordance with applicable requirements of the CSWGP.
- Maintain an updated SWPPP.
 - The SWPPP will be updated, maintained, and implemented in accordance with Special Conditions S3, S4, and S9 of the CSWGP.

As site work progresses the SWPPP will be modified routinely to reflect changing site conditions. The SWPPP will be reviewed monthly to ensure the content is current.

Table 5 – Management

✓	Design the project to fit the existing topography, soils, and drainage patterns
✓	Emphasize erosion control rather than sediment control
✓	Minimize the extent and duration of the area exposed
✓	Keep runoff velocities low
✓	Retain sediment on-site
✓	Thoroughly monitor site and maintain all ESC measures
✓	Schedule major earthwork during the dry season
	Other (please describe)

Element 13: Protect Low Impact Development (LID) BMPs (2.1.13)

Restore all facilities to fully functioning condition if they accumulate sediment during construction, including the removal of sediments and any sediment-laden soils within an infiltration BMP to meet the original design specifications.

Infiltration BMPs shall be protected from compaction by construction equipment and foot traffic. Protect completed lawn and landscaped areas from compaction during construction. All heavy equipment shall be kept off of existing soils under LID facilities that have been excavated to final grade to retain the infiltration rate of the soils.

List and describe BMPs:

- Silt Fence (BMP C233)
 - Silt fence will be used where delineated on the Temporary Erosion and Sediment Control (TESC) Plan to protect areas that should not be disturbed and to control on-site sedimentation throughout the construction process.

Installation Schedules: To be completed by Contractor and CESCL

Inspection and Maintenance plan: See Appendix B

Responsible Staff: Certified Erosion and Sediment Control Lead

Pollution Prevention Team (3.0)

Table 7 – Team Information

Title	Name(s)	Phone Number
Certified Erosion and Sediment Control Lead (CESCL)	TBD	TBD
Resident Engineer	TBD	TBD
Emergency Ecology Contact	TBD	TBD
Emergency Permittee/ Owner Contact	TBD	TBD
Non-Emergency Owner Contact	TBD	TBD
Monitoring Personnel	CESCL – See Above	
Ecology Regional Office	Southwest Region Office – Lacey	360-407-6300

Monitoring and Sampling Requirements (4.0)

Monitoring includes visual inspection, sampling for water quality parameters of concern, and documentation of the inspection and sampling findings in a site log book. A site log book will be maintained for all on-site construction activities and will include:

- A record of the implementation of the SWPPP and other permit requirements
- Site inspections
- Stormwater sampling data

See site inspection form under Appendix D.

The site log book must be maintained on-site within reasonable access to the site and be made available upon request to Ecology or the local jurisdiction.

Numeric effluent limits may be required for certain discharges to 303(d) listed waterbodies. See CSWGP Special Condition S8 and Section 5 of this template.

Site Inspection (4.1)

Site inspections will be conducted at least once every calendar week and within 24 hours following any discharge from the site. For sites that are temporarily stabilized and inactive, the required frequency is reduced to once per calendar month.

The discharge point(s) are indicated on the Site Map (see Appendix A) and in accordance with the applicable requirements of the CSWGP.

Stormwater Quality Sampling (4.2)

Turbidity Sampling (4.2.1)

Requirements include calibrated turbidity meter or transparency tube to sample site discharges for compliance with the CSWGP. Sampling will be conducted at all discharge points at least once per calendar week.

Method for sampling turbidity:

Table 8 – Turbidity Sampling Method

	Turbidity Meter/Turbidimeter (required for disturbances 5 acres or greater in size)
✓	Transparency Tube (option for disturbances less than 1 acre and up to 5 acres in size)

The benchmark for turbidity value is 25 nephelometric turbidity units (NTU) and a transparency less than 33 centimeters.

If the discharge's turbidity is 26 to 249 NTU or the transparency is less than 33 cm but equal to or greater than 6 cm, the following steps will be conducted:

1. Review the SWPPP for compliance with Special Condition S9. Make appropriate revisions within 7 days of the date the discharge exceeded the benchmark.
2. Immediately begin the process to fully implement and maintain appropriate source control and/or treatment BMPs as soon as possible. Address the problems within 10 days of the date the discharge exceeded the benchmark. If installation of necessary treatment BMPs is not feasible within 10 days, Ecology may approve additional time when the Permittee requests an extension within the initial 10-day response period.
3. Document BMP implementation and maintenance in the site log book.

If the turbidity exceeds 250 NTU or the transparency is 6 cm or less at any time, the following steps will be conducted:

1. Telephone or submit an electronic report to the applicable Ecology Region's Environmental Report Tracking System (ERTS) within 24 hours.
<https://www.ecology.wa.gov/About-us/Get-involved/Report-an-environmental-issue>
 - Southwest Region (Clallam, Clark, Cowlitz, Grays Harbor, Jefferson, Lewis, Mason, Pacific, Pierce, Skamania, Thurston, Wahkiakum,): (360) 407-6300
2. Immediately begin the process to fully implement and maintain appropriate source control and/or treatment BMPs as soon as possible. Address the problems within 10 days of the date the discharge exceeded the benchmark. If installation of necessary treatment BMPs is not feasible within 10 days, Ecology may approve additional time when the Permittee requests an extension within the initial 10-day response period
3. Document BMP implementation and maintenance in the site log book.
4. Continue to sample discharges daily until one of the following is true:
 - Turbidity is 25 NTU (or lower).
 - Transparency is 33 cm (or greater).
 - Compliance with the water quality limit for turbidity is achieved.
 - 1 - 5 NTU over background turbidity, if background is less than 50 NTU
 - 1% - 10% over background turbidity, if background is 50 NTU or greater
 - The discharge stops or is eliminated.

pH Sampling (4.2.2)

pH monitoring is required for “Significant concrete work” (i.e. greater than 1000 cubic yards poured concrete or recycled concrete over the life of the project). The use of engineered soils (soil amendments including but not limited to Portland cement-treated base [CTB], cement kiln dust [CKD] or fly ash) also requires pH monitoring.

For significant concrete work, pH sampling will start the first day concrete is poured and continue until it is cured, typically three (3) weeks after the last pour.

For engineered soils and recycled concrete, pH sampling begins when engineered soils or recycled concrete are first exposed to precipitation and continues until the area is fully stabilized.

If the measured pH is 8.5 or greater, the following measures will be taken:

1. Prevent high pH water from entering storm sewer systems or surface water.
2. Adjust or neutralize the high pH water to the range of 6.5 to 8.5 su using appropriate technology such as carbon dioxide (CO₂) sparging (liquid or dry ice).
3. Written approval will be obtained from Ecology prior to the use of chemical treatment other than CO₂ sparging or dry ice.

Method for sampling pH: N/A. We are not proposing greater than 1,000 CY of concrete, so no pH sampling is required.

Table 9 – pH Sampling Method

	pH meter
x	pH test kit
	Wide range pH indicator paper

Discharges to 303(d) or Total Maximum Daily Load (TMDL) Waterbodies (5.0)

303(d) Listed Waterbodies (5.1)

Is the receiving water 303(d) (Category 5) listed for turbidity, fine sediment, phosphorus, or pH?

Yes **No**

List the impairment(s):

- N/A

The receiving waterbody, Unnamed Perennial Stream, is impaired for: N/A.

All stormwater and dewatering discharges from the site are subject to an effluent limit of 8.5 su for pH and/or 25 NTU for turbidity.

If yes, discharges must comply with applicable effluent limitations in S8.C and S8.D of the CSWGP.

Describe the method(s) for 303(d) compliance:

List and describe BMPs:

- N/A

TMDL Waterbodies (5.2)

Waste Load Allocation for CWSGP discharges:

N/A

Discharges to TMDL receiving waterbodies will meet in-stream water quality criteria at the point of discharge.
--

The Construction Stormwater General Permit Proposed New Discharge to an Impaired Water Body form is included in Appendix F.

Reporting and Record Keeping (6.0)

Record Keeping (6.1)

Site Log Book (6.1.1)

A site log book will be maintained for all on-site construction activities and will include:

- A record of the implementation of the SWPPP and other permit requirements
- Site inspections
- Sample logs

Records Retention (6.1.2)

Records will be retained during the life of the project and for a minimum of three (3) years following the termination of permit coverage in accordance with Special Condition S5.C of the CSWGP.

Permit documentation to be retained on-site:

- CSWGP
- Permit Coverage Letter
- SWPPP
- Site Log Book

Permit documentation will be provided within 14 days of receipt of a written request from Ecology. A copy of the SWPPP or access to the SWPPP will be provided to the public when requested in writing in accordance with Special Condition S5.G.2.b of the CSWGP.

Updating the SWPPP (6.1.3)

The SWPPP will be modified if:

- Found ineffective in eliminating or significantly minimizing pollutants in stormwater discharges from the site.
- There is a change in design, construction, operation, or maintenance at the construction site that has, or could have, a significant effect on the discharge of pollutants to waters of the State.

The SWPPP will be modified within seven (7) days if inspection(s) or investigation(s) determine additional or modified BMPs are necessary for compliance. An updated timeline for BMP implementation will be prepared.

Reporting (6.2)

Discharge Monitoring Reports (6.2.1)

Cumulative soil disturbance is one (1) acre or larger; therefore, Discharge Monitoring Reports (DMRs) will be submitted to Ecology monthly. If there was no discharge during a given monitoring period the DMR will be submitted as required, reporting “No Discharge”. The DMR due date is fifteen (15) days following the end of each calendar month.

DMRs will be reported online through Ecology’s WQWebDMR System.

To sign up for WQWebDMR go to:

<https://www.ecology.wa.gov/Regulations-Permits/Guidance-technical-assistance/Water-quality-permits-guidance/WQWebPortal-guidance>

Notification of Noncompliance (6.2.2)

If any of the terms and conditions of the permit is not met, and the resulting noncompliance may cause a threat to human health or the environment, the following actions will be taken:

1. Ecology will be notified within 24-hours of the failure to comply by calling the applicable Regional office ERTS phone number (Regional office numbers listed below).
2. Immediate action will be taken to prevent the discharge/pollution or otherwise stop or correct the noncompliance. If applicable, sampling and analysis of any noncompliance will be repeated immediately and the results submitted to Ecology within five (5) days of becoming aware of the violation.
3. A detailed written report describing the noncompliance will be submitted to Ecology within five (5) days, unless requested earlier by Ecology.

Anytime turbidity sampling indicates turbidity is 250 NTUs or greater, or water transparency is 6 cm or less, the Ecology Regional office will be notified by phone within 24 hours of analysis as required by Special Condition S5.A of the CSWGP.

- Southwest Region at (360) 407-6300 for Clallam, Clark, Cowlitz, Grays Harbor, Jefferson, Lewis, Mason, Pacific, Pierce, Skamania, Thurston, or Wahkiakum

Include the following information:

1. Your name and / Phone number
2. Permit number
3. City / County of project
4. Sample results
5. Date / Time of call
6. Date / Time of sample

7. Project name

In accordance with Special Condition S4.D.5.b of the CSWGP, the Ecology Regional office will be notified if chemical treatment other than CO₂ sparging is planned for adjustment of high pH water.

Appendix/Glossary

A. Site Map

GRADING & DRAINAGE NOTES

- ALL CONSTRUCTION TO BE IN ACCORDANCE WITH THESE PLANS AND THE CITY/AHJ STANDARDS AND SPECIFICATIONS.
- PRIOR TO STARTING CONSTRUCTION, THE CONTRACTOR SHALL MAKE CERTAIN THAT ALL REQUIRED PERMITS AND APPROVALS HAVE BEEN OBTAINED. NO CONSTRUCTION OR FABRICATION SHALL BEGIN UNTIL THE CONTRACTOR HAS RECEIVED AND THOROUGHLY REVIEWED ALL PLANS AND OTHER DOCUMENTS APPROVED BY ALL OF THE PERMITTING AUTHORITIES.
- THE GENERAL CONTRACTOR AND ALL SUB-CONTRACTORS SHALL VERIFY THE SUITABILITY OF ALL EXISTING AND PROPOSED SITE CONDITIONS INCLUDING GRADES AND DIMENSIONS BEFORE COMMENCEMENT OF ANY CONSTRUCTION. THE ENGINEER SHALL BE NOTIFIED IMMEDIATELY OF ANY DISCREPANCIES. MINOR ADJUSTMENTS TO FINISH GRADE TO ACCOMPLISH SPOT DRAINAGE ARE ACCEPTABLE. IF NECESSARY, UPON PRIOR APPROVAL OF ENGINEER, PAVING INSTALLED SHALL "FLUSH OUT" AT ANY JUNCTURE WITH EXISTING PAVING.
- THE CONTRACTOR IS SPECIFICALLY CAUTIONED THAT THE LOCATION AND/OR ELEVATION OF EXISTING UTILITIES AS SHOWN ON THESE PLANS IS BASED ON RECORDS OF THE VARIOUS UTILITY COMPANIES, AND WHERE POSSIBLE, MEASUREMENTS TAKEN IN THE FIELD. THE INFORMATION IS NOT TO BE RELIED ON AS BEING EXACT OR COMPLETE. THE CONTRACTOR MUST CALL THE APPROPRIATE UTILITY COMPANIES AT LEAST 72 HOURS BEFORE ANY EXCAVATION TO REQUEST EXACT FIELD LOCATION OF UTILITIES. IT SHALL BE THE RESPONSIBILITY OF THE CONTRACTOR TO RELOCATE ALL EXISTING UTILITIES WHICH CONFLICT WITH THE PROPOSED IMPROVEMENTS SHOWN ON THE PLANS.
- ALL CUT OR FILL SLOPES SHALL BE 4:1 OR FLATTER UNLESS OTHERWISE NOTED.
- CONTRACTOR SHALL ADJUST AND/OR CUT EXISTING PAVEMENT AS NECESSARY TO ASSURE A SMOOTH FIT AND CONTINUOUS GRADE.
- CONTRACTOR SHALL ASSURE POSITIVE DRAINAGE AWAY FROM BUILDINGS FOR ALL NATURAL AND PAVED AREAS.
- TOPOGRAPHIC INFORMATION IS TAKEN FROM A TOPOGRAPHIC SURVEY BY LAND SURVEYORS. IF THE CONTRACTOR DOES NOT ACCEPT EXISTING TOPOGRAPHY AS SHOWN ON THE PLANS, WITHOUT EXCEPTION, THEN THE CONTRACTOR SHALL SUPPLY, AT THEIR EXPENSE, A TOPOGRAPHIC SURVEY BY A REGISTERED LAND SURVEYOR TO THE OWNER FOR REVIEW.
- CONTRACTOR SHALL REFER TO ARCHITECTURAL PLANS FOR EXACT BUILDING FOOTPRINT DIMENSIONS.
- CONTRACTOR SHALL REFER TO FINAL GEOTECH REPORT FOR BUILDING SUBGRADE AND SITE PREPARATION REQUIREMENTS.
- CONTRACTOR SHALL ADJUST EXISTING VALVES, MANHOLE RIMS, ETC. AS NECESSARY TO MATCH FINISHED GRADE.
- GRADING FOR ALL SIDEWALKS AND ACCESSIBLE ROUTES INCLUDING CROSSING DRIVEWAYS SHALL CONFORM TO ADA STANDARDS. SLOPES SHALL NOT EXCEED 5% LONGITUDINAL SLOPE OR 2% CROSS SLOPE. SIDEWALK ACCESS TO EXTERNAL BUILDING DOORS SHALL BE ADA COMPLIANT. CONTRACTOR SHALL NOTIFY ENGINEER IMMEDIATELY IF ADA CRITERIA CANNOT BE MET AT ANY LOCATION.
- ANY PROPOSED CONTOURS SHOWN ARE APPROXIMATE. PROPOSED SPOT ELEVATIONS AND DESIGNATED GRADIENT ARE TO BE USED IN THE EVENT OF ANY DISCREPANCIES.
- ALL FILL TO BE PLACED SHALL BE IN ACCORDANCE WITH THE CURRENT APPLICABLE GEOTECHNICAL REPORT RECOMMENDATIONS.

GRADING SUMMARY TABLE

CUT: 131 CUBIC YARDS
 FILL: 554 CUBIC YARDS
 NET FILL: 422 CUBIC YARDS

NOTE: THE ABOVE QUANTITIES ARE APPROXIMATE IN PLACE VOLUMES CALCULATED FROM THE EXISTING GROUND TO THE PROPOSED FINISHED GRADE.

THE EARTHWORK QUANTITIES ABOVE ARE APPROXIMATE. THEY HAVE NOT BEEN FACTORED TO ACCOUNT FOR CHANGES IN VOLUME DUE TO BUILDING, CLEARING AND GRUBBING, SHRINKAGE, OVER-EXCAVATION AND RE-COMPACTION, AND CONSTRUCTION METHODS. NOR DO THEY ACCOUNT FOR THE THICKNESS OF PAVEMENT SECTIONS, FOOTINGS, SLABS, REUSE OF PULVERIZED MATERIALS THAT WILL UNDERLIE NEW PAVEMENTS, ETC. THE CONTRACTOR SHALL RELY ON THEIR OWN EARTHWORK ESTIMATES FOR BIDDING PURPOSES.

APPROXIMATE AREAS OF EXCAVATION AND FILL HAVE BEEN NOTED IN THE PLANS AND LEGEND. AREAS OUTSIDE THESE LIMITS ARE AREAS OF LESS THAN ONE FOOT OR ZERO FILL AND EXCAVATION.

LEGEND

- PROPERTY LINE
- - - LEASE LINE
- - - EASEMENT LINE
- - - APPROXIMATE CIVIL LIMIT OF WORK LINE
- - - EXISTING CONTOUR
- - - PROPOSED CONTOUR
- - - GRADE BREAK LINE
- - - LOW POINT LINE
- - - RIDGE LINE
- XXX.XX PROPOSED SPOT ELEVATION
- (XXX.XX) EXISTING SPOT ELEVATION
- 2.00% PROPOSED FLOW (DIRECTION AND SLOPE)
- FFE FINISHED FLOOR ELEVATION
- SW TOP OF SIDEWALK
- ME MATCH EXISTING ELEVATION
- BC BOTTOM OF CURB
- TC TOP OF CURB
- FG FINISHED GRADE
- TW TOP OF WALL
- BW BOTTOM OF WALL

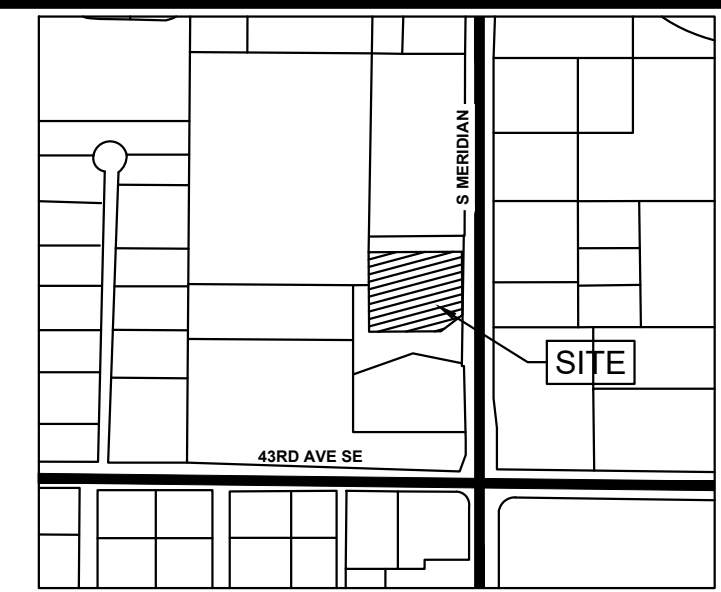
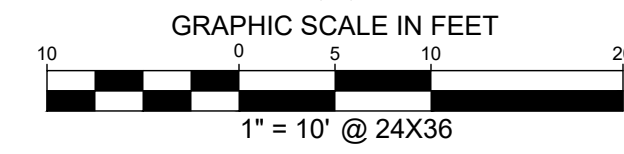

PM DESIGN

211 GATEWAY RD W
 SUITE 208
 NAPA, CA 94558
 CONTACT: CHET RUST
 PHONE: 707.475.5670
 EMAIL: CRUST@PMDC.COM

JEFF LIEBERMAN, ARCHITECT
 PM DESIGN GROUP, INC.



CONSULTANT:

Kimley-Horn

© 2026 KIMLEY-HORN AND ASSOCIATES, INC.

1201 Third Ave.
 Suite 2800
 Seattle, WA 98101
 CONTACT:
 LIZ WILLMOT, P.E.
 (206) 677-8610
 LIZ.WILLMOT@KIMLEY-HORN.COM



RAISING CANE'S
 RESTAURANT NO.: #C1360

4110 SOUTH MERIDIAN
 PUYALLUP, WA 98373

PROTOTYPE P&E-AV
 SCHEME
 VERSION 2025-1.0

REV	DATE	DESCRIPTION
02/24/26		80% CLIENT REVIEW SET
03/10/26		1ST CITY SUBMITTAL

DRAWN BY:
 CHECKED BY:
 ARCH. PROJECT NO.:
RAC25014.0
 SHEET NAME:

GRADING & DRAINAGE PLAN

SHEET NUMBER:
C5.0

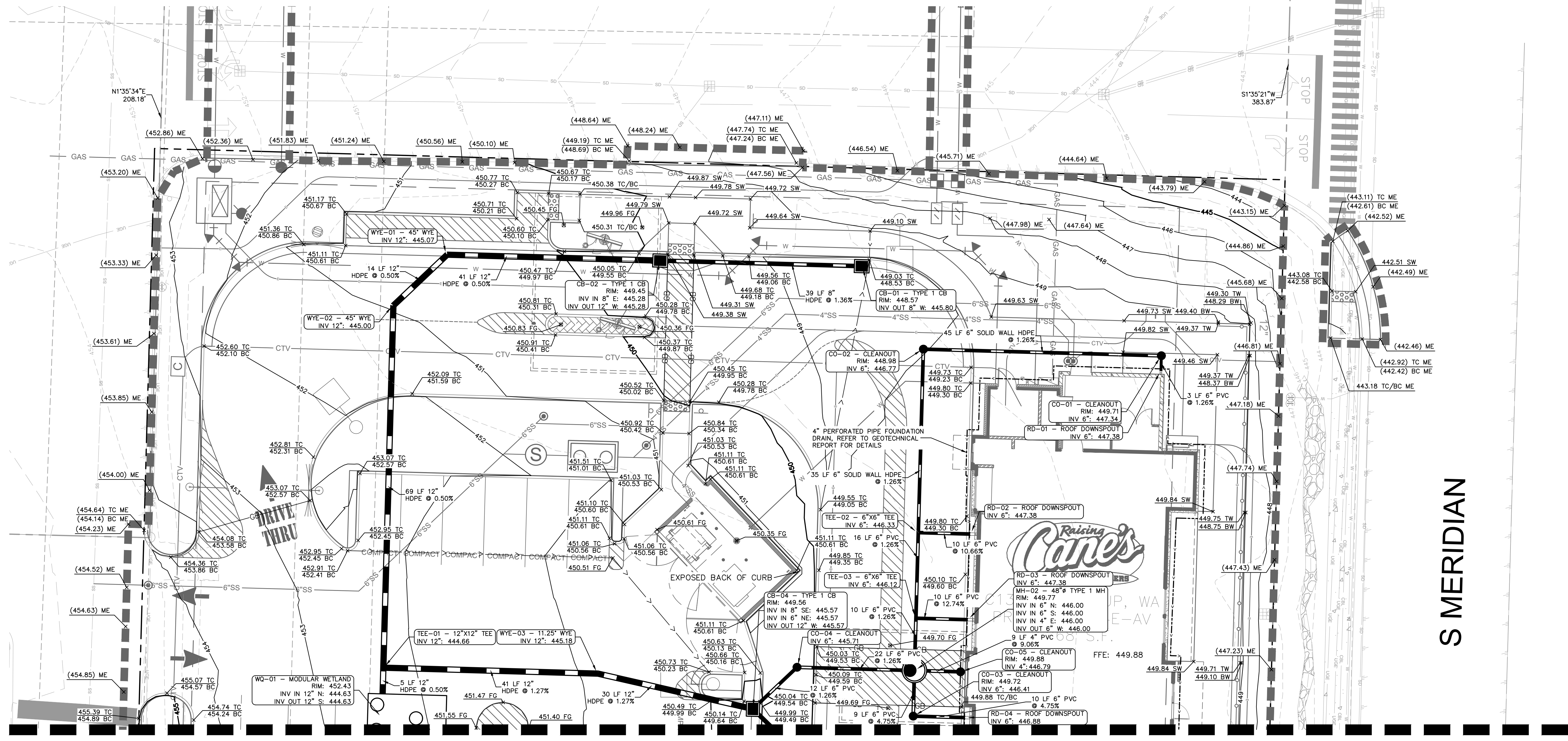

MATCHLINE - REFER TO SHEET C5.1

K:\SEA_Civil\090042 - Raising Cane's\090042022 - C1360 Meridian & 43rd, Puyallup, WA\CAD\PlanSheets\C5.0 GRADING & DRAINAGE PLAN.dwg Mar 10, 2026 2:30pm by: Toym,Chloehm

This document, together with the concepts and designs presented herein, is intended only for the specific purpose and client for which it was prepared. Review of and improper reliance on this document without written authorization and adaptation by Kimley-Horn and Associates, Inc. shall be without liability to Kimley-Horn and Associates, Inc.

1ST CITY SUBMITTAL : 03/10/26

GRADING & DRAINAGE NOTES

- ALL CONSTRUCTION TO BE IN ACCORDANCE WITH THESE PLANS AND THE CITY/AHJ STANDARDS AND SPECIFICATIONS.
- PRIOR TO STARTING CONSTRUCTION, THE CONTRACTOR SHALL MAKE CERTAIN THAT ALL REQUIRED PERMITS AND APPROVALS HAVE BEEN OBTAINED. NO CONSTRUCTION OR FABRICATION SHALL BEGIN UNTIL THE CONTRACTOR HAS RECEIVED AND THOROUGHLY REVIEWED ALL PLANS AND OTHER DOCUMENTS APPROVED BY ALL OF THE PERMITTING AUTHORITIES.
- THE GENERAL CONTRACTOR AND ALL SUB-CONTRACTORS SHALL VERIFY THE SUITABILITY OF ALL EXISTING AND PROPOSED SITE CONDITIONS INCLUDING GRADES AND DIMENSIONS BEFORE COMMENCEMENT OF ANY CONSTRUCTION. THE ENGINEER SHALL BE NOTIFIED IMMEDIATELY OF ANY DISCREPANCIES. MINOR ADJUSTMENTS TO FINISH GRADE TO ACCOMPLISH SPOT DRAINAGE ARE ACCEPTABLE. IF NECESSARY, UPON PRIOR APPROVAL OF ENGINEER, PAVING INSTALLED SHALL "FLUSH OUT" AT ANY JUNCTURE WITH EXISTING PAVING.
- THE CONTRACTOR IS SPECIFICALLY CAUTIONED THAT THE LOCATION AND/OR ELEVATION OF EXISTING UTILITIES AS SHOWN ON THESE PLANS IS BASED ON RECORDS OF THE VARIOUS UTILITY COMPANIES, AND WHERE POSSIBLE, MEASUREMENTS TAKEN IN THE FIELD. THE INFORMATION IS NOT TO BE RELIED ON AS BEING EXACT OR COMPLETE. THE CONTRACTOR MUST CALL THE APPROPRIATE UTILITY COMPANIES AT LEAST 72 HOURS BEFORE ANY EXCAVATION TO REQUEST EXACT FIELD LOCATION OF UTILITIES. IT SHALL BE THE RESPONSIBILITY OF THE CONTRACTOR TO RELOCATE ALL EXISTING UTILITIES WHICH CONFLICT WITH THE PROPOSED IMPROVEMENTS SHOWN ON THE PLANS.
- ALL CUT OR FILL SLOPES SHALL BE 4:1 OR FLATTER UNLESS OTHERWISE NOTED.
- CONTRACTOR SHALL ADJUST AND/OR CUT EXISTING PAVEMENT AS NECESSARY TO ASSURE A SMOOTH FIT AND CONTINUOUS GRADE.
- CONTRACTOR SHALL ASSURE POSITIVE DRAINAGE AWAY FROM BUILDINGS FOR ALL NATURAL AND PAVED AREAS.
- TOPOGRAPHIC INFORMATION IS TAKEN FROM A TOPOGRAPHIC SURVEY BY LAND SURVEYORS. IF THE CONTRACTOR DOES NOT ACCEPT EXISTING TOPOGRAPHY AS SHOWN ON THE PLANS, WITHOUT EXCEPTION, THEN THE CONTRACTOR SHALL SUPPLY, AT THEIR EXPENSE, A TOPOGRAPHIC SURVEY BY A REGISTERED LAND SURVEYOR TO THE OWNER FOR REVIEW.
- CONTRACTOR SHALL REFER TO ARCHITECTURAL PLANS FOR EXACT BUILDING FOOTPRINT DIMENSIONS.
- CONTRACTOR SHALL REFER TO FINAL GEOTECH REPORT FOR BUILDING SUBGRADE AND SITE PREPARATION REQUIREMENTS.
- CONTRACTOR SHALL ADJUST EXISTING VALVES, MANHOLE RIMS, ETC. AS NECESSARY TO MATCH FINISHED GRADE.
- GRADING FOR ALL SIDEWALKS AND ACCESSIBLE ROUTES INCLUDING CROSSING DRIVEWAYS SHALL CONFORM TO ADA STANDARDS. SLOPES SHALL NOT EXCEED 5% LONGITUDINAL SLOPE OR 2% CROSS SLOPE. SIDEWALK ACCESS TO EXTERNAL BUILDING DOORS SHALL BE ADA COMPLIANT. CONTRACTOR SHALL NOTIFY ENGINEER IMMEDIATELY IF ADA CRITERIA CANNOT BE MET AT ANY LOCATION.
- ANY PROPOSED CONTOURS SHOWN ARE APPROXIMATE. PROPOSED SPOT ELEVATIONS AND DESIGNATED GRADIENT ARE TO BE USED IN THE EVENT OF ANY DISCREPANCIES.
- ALL FILL TO BE PLACED SHALL BE IN ACCORDANCE WITH THE CURRENT APPLICABLE GEOTECHNICAL REPORT RECOMMENDATIONS.

LEGEND

- PROPERTY LINE
- - - LEASE LINE
- - - EASEMENT LINE
- - - APPROXIMATE CIVIL LIMIT OF WORK LINE
- - - EXISTING CONTOUR
- XXX PROPOSED CONTOUR
- GB GRADE BREAK LINE
- < - < LOW POINT LINE
- R RIDGE LINE
- XXX.XX PROPOSED SPOT ELEVATION
- (XXX.XX) EXISTING SPOT ELEVATION
- 2.00% PROPOSED FLOW (DIRECTION AND SLOPE)
- FFE FINISHED FLOOR ELEVATION
- SW TOP OF SIDEWALK
- ME MATCH EXISTING ELEVATION
- BC BOTTOM OF CURB
- TC TOP OF CURB
- FG FINISHED GRADE
- TW TOP OF WALL
- BW BOTTOM OF WALL

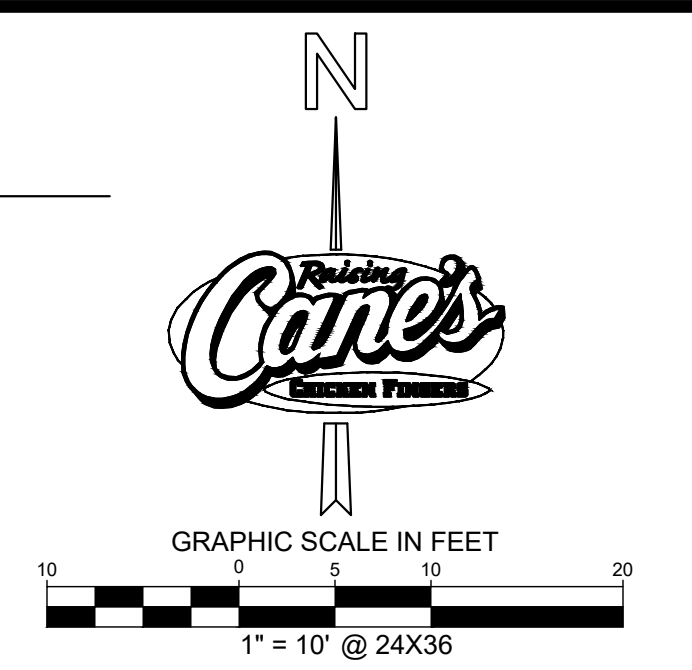

MATCHLINE - REFER TO SHEET C5.0

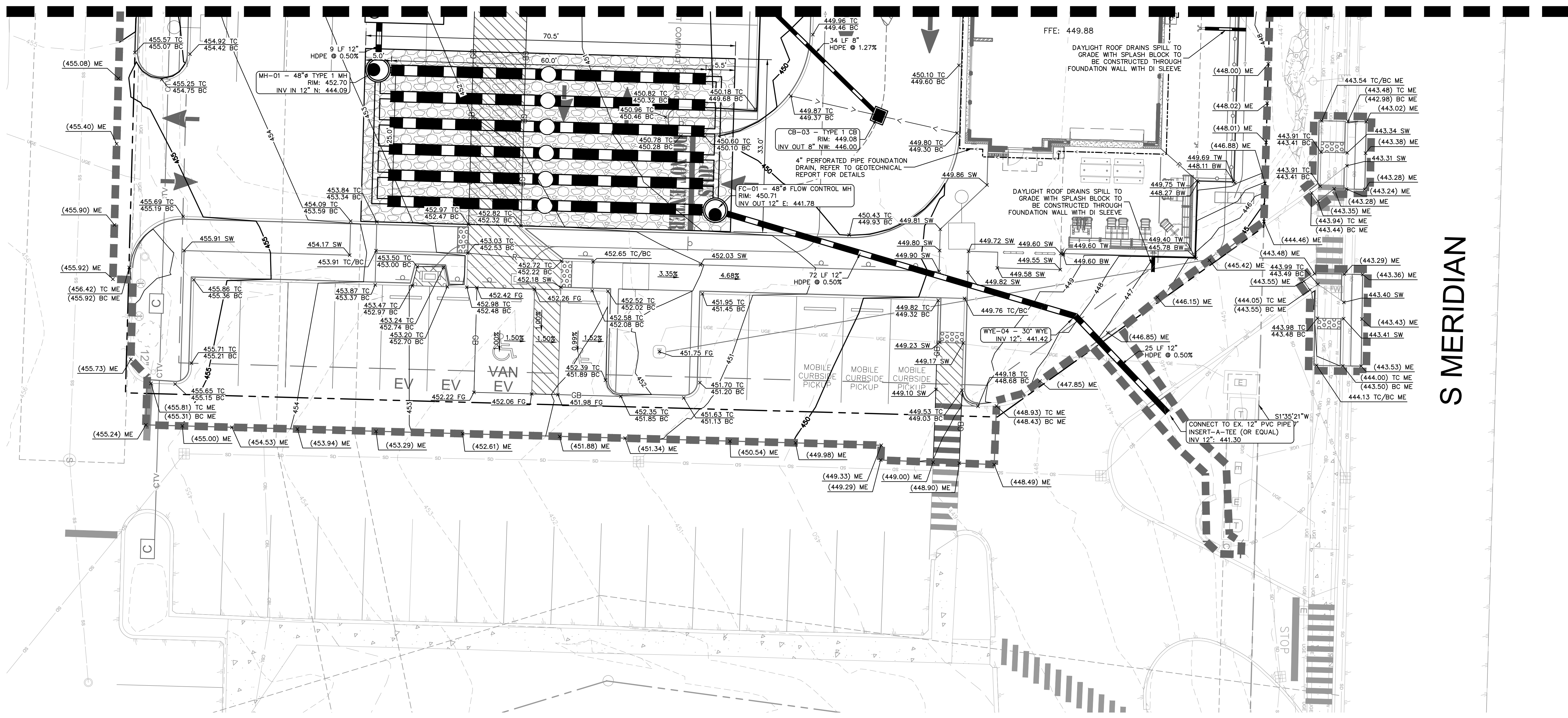

S MERIDIAN

PM DESIGN
 211 GATEWAY RD W
 SUITE 208
 NAPA, CA 94558
 CONTACT: CHET RUST
 PHONE: 707.475.5670
 EMAIL: CRUST@PMDESIGN.COM
 JEFF LIEDERMAN, ARCHITECT
 PM DESIGN GROUP, INC.



CONSULTANT:
Kimley-Horn
 © 2026 KIMLEY-HORN AND ASSOCIATES, INC.
 1201 Third Ave.
 Suite 2800
 Seattle, WA 98101
 CONTACT:
 LIZ WILLMOT, P.E.
 (206) 677-8610
 LIZ.WILLMOT@KIMLEY-HORN.COM



RAISING CANE'S
 RESTAURANT NO.: #C1360
 4110 SOUTH MERIDIAN
 PUYALLUP, WA 98373

REV	DATE	DESCRIPTION
02/24/26		80% CLIENT REVIEW SET
03/10/26		1ST CITY SUBMITTAL

DRAWN BY:
 CHECKED BY:
 ARCH. PROJECT NO.:
RAC25014.0
 SHEET NAME:
GRADING & DRAINAGE PLAN
 SHEET NUMBER:
C5.1

K:\SEA_Civil\090042 - Raising Cane's\090042022 - C1360 Meridian & 43rd, Puyallup, WA\CAD\PlanSheets\C5.0 GRADING & DRAINAGE PLAN.dwg Mar 10, 2026 2:30pm by: Toym,Chiehelm

This document, together with the concepts and designs presented herein, is an instrument of service, as an instrument of service, as intended only for the specific purpose and client for which it was prepared. Release of and improper reliance on this document without written authorization and adaptation by Kimley-Horn and Associates, Inc. shall be without liability to Kimley-Horn and Associates, Inc.

1ST CITY SUBMITTAL : 03/10/26

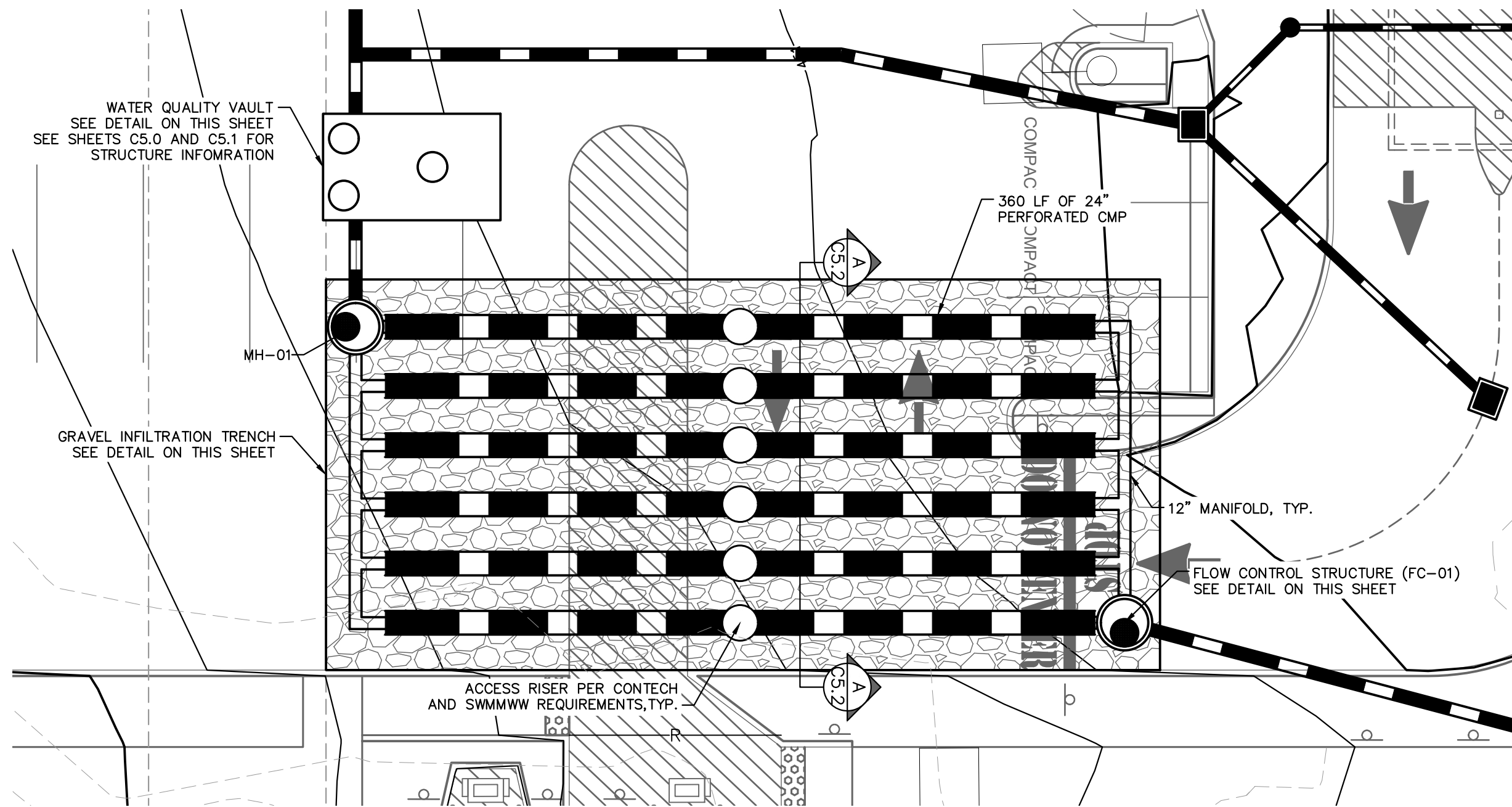

GRAVEL TRENCH - PLAN VIEW
SCALE: 1" = 10'

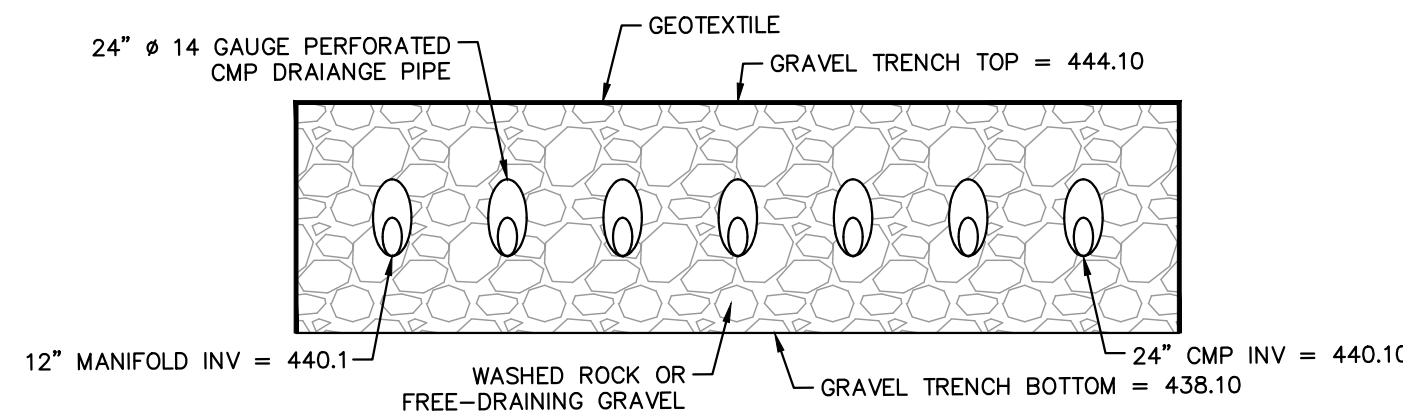

GRAVEL TRENCH - SECTION A-A
H: 1" = 10'
V: 1" = 5'

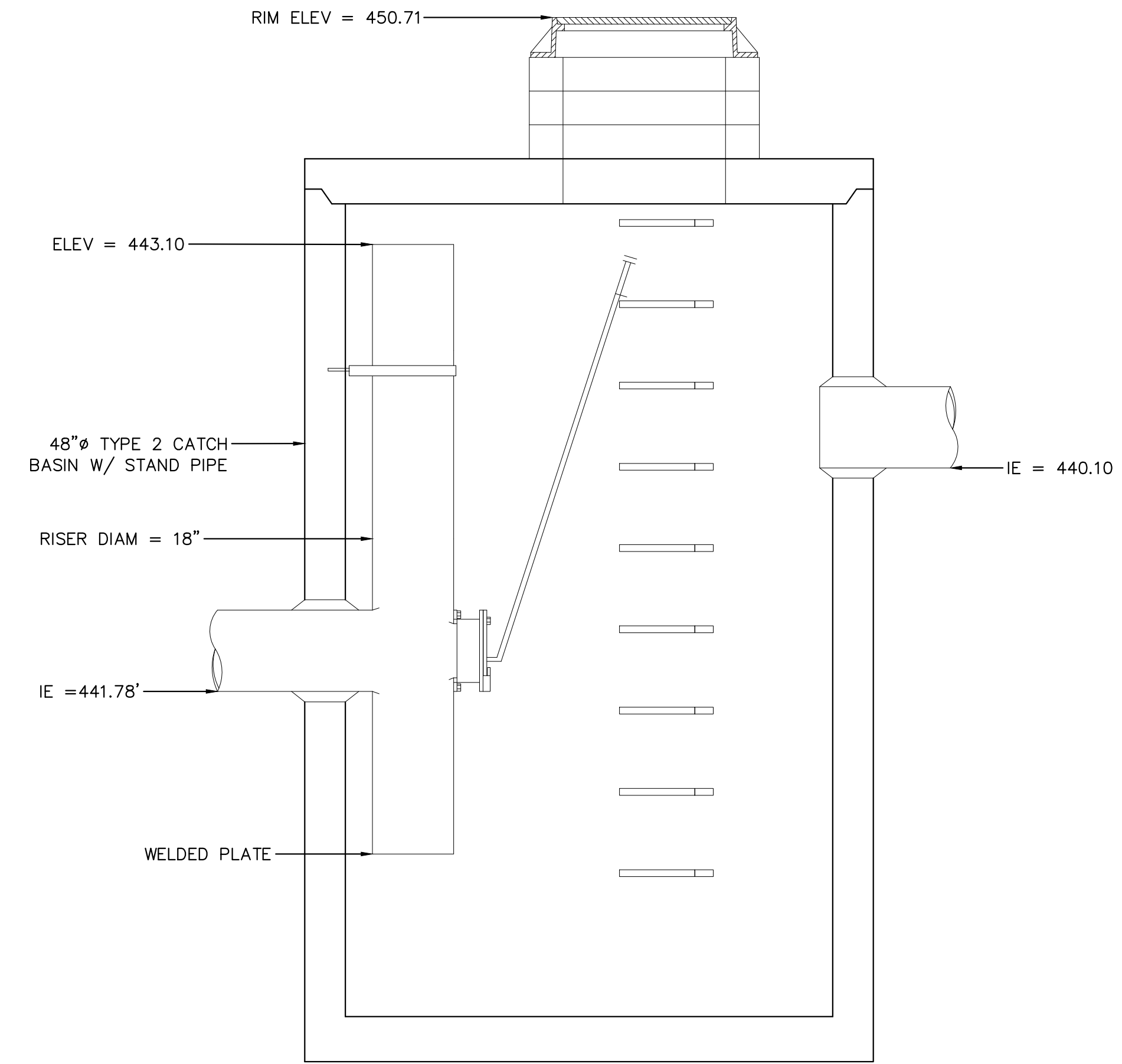

FLOW CONTROL STRUCTURE (FC-01) DETAIL
NTS

SITE SPECIFIC DATA			
PROJECT NUMBER			
PROJECT NAME			
PROJECT LOCATION			
STRUCTURE ID			
TREATMENT REQUIRED			
TREATMENT FLOW (CFS)			
PRETREATMENT LOADING RATE (GPM/SF)	2.1 GPM/SF		
WETLAND MEDIA LOADING RATE (GPM/SF)	1.0		
PEAK BYPASS REQUIRED (CFS) - IF APPLICABLE	(CFS)		
PIPE DATA	I.E.	MATERIAL	DIAMETER
INLET PIPE 1			
INLET PIPE 2			
OUTLET PIPE			
	PRETREATMENT	BIOFILTRATION	DISCHARGE
RIM ELEVATION			
SURFACE LOAD	PEDESTRIAN		
NOTES:			

* PRELIMINARY ONLY - NOT FOR CONSTRUCTION

INSTALLATION NOTES

- CONTRACTOR TO PROVIDE ALL LABOR, EQUIPMENT, MATERIALS AND INCIDENTALS REQUIRED TO OFFLOAD AND INSTALL THE SYSTEM AND APPURTENANCES IN ACCORDANCE WITH THIS DRAWING AND THE MANUFACTURER'S SPECIFICATIONS, UNLESS OTHERWISE STATED IN MANUFACTURER'S CONTRACT.
- UNIT MUST BE INSTALLED ON LEVEL BASE. MANUFACTURER RECOMMENDS A MINIMUM 6" LEVEL ROCK BASE UNLESS SPECIFIED BY THE PROJECT ENGINEER. CONTRACTOR IS RESPONSIBLE FOR VERIFYING PROJECT ENGINEER'S RECOMMENDED BASE SPECIFICATIONS.
- CONTRACTOR TO SUPPLY AND INSTALL ALL EXTERNAL CONNECTING PIPES. ALL PIPES MUST BE FLUSH WITH INSIDE SURFACE OF CONCRETE (PIPES CANNOT INTRUDE BEYOND FLUSH). INVERT OF OUTFLOW PIPE MUST BE FLUSH WITH DISCHARGE CHAMBER FLOOR. ALL PIPES SHALL BE SEALED WATERTIGHT PER MANUFACTURER'S STANDARD CONNECTION DETAIL.
- CONTRACTOR RESPONSIBLE FOR CONTACTING CONTECH FOR ACTIVATION OF UNIT. MANUFACTURER'S WARRANTY IS VOID WITHOUT PROPER ACTIVATION BY A CONTECH REPRESENTATIVE.
- VERTICAL HEIGHT VARIES BASED ON SITE SPECIFIC REQUIREMENTS.

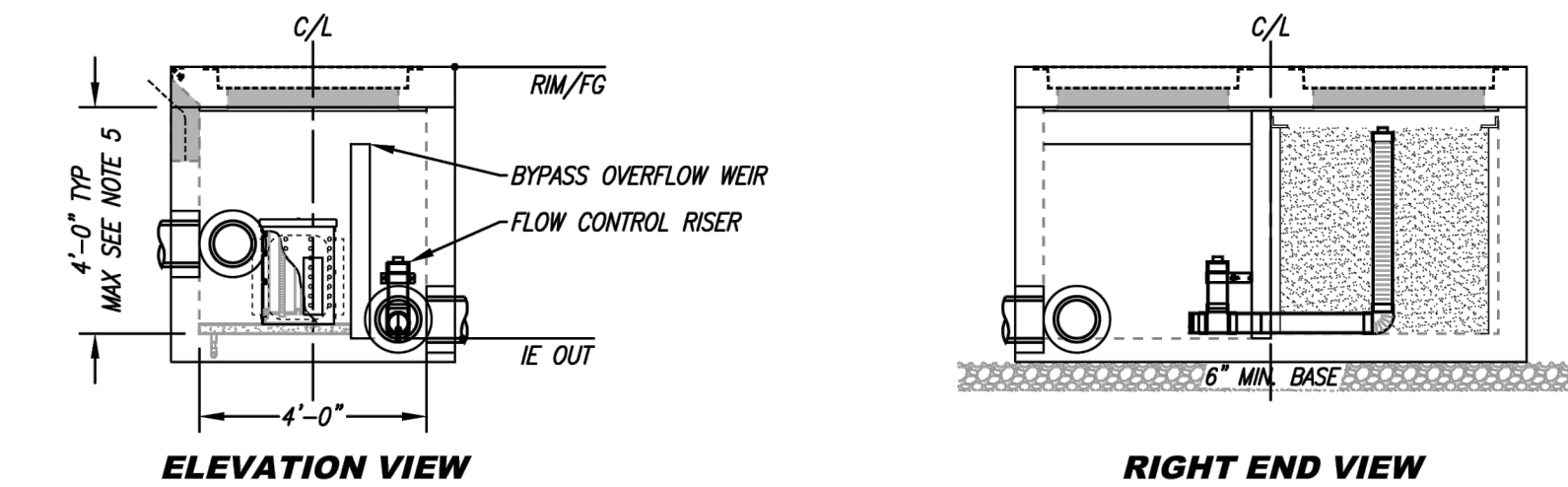
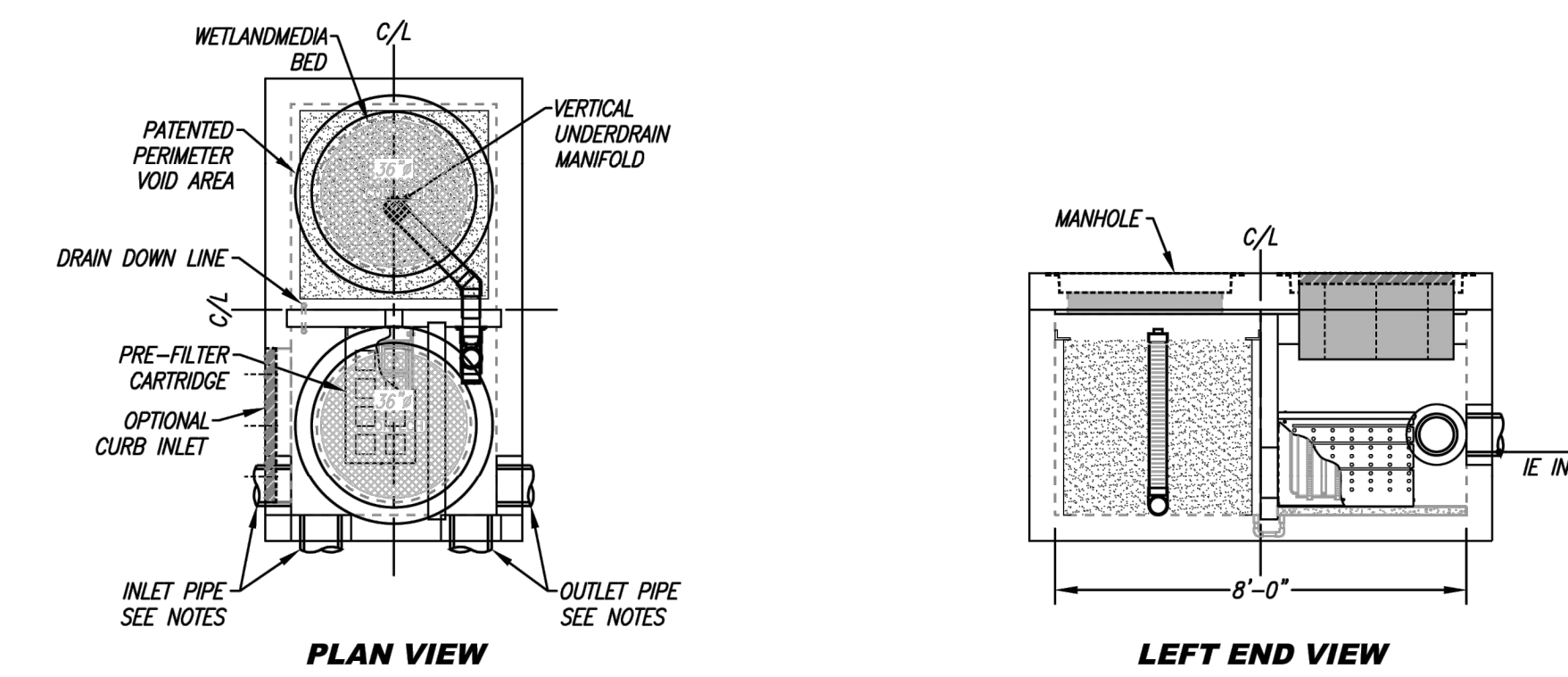

MODULAR WETLAND (WQ-01) DETAIL
NTS

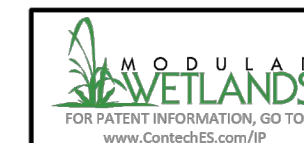

PROPRIETARY AND CONFIDENTIAL
THE INFORMATION CONTAINED IN THIS DOCUMENT IS THE SOLE PROPERTY OF CONTECH AND ITS COMPANIES. THIS DOCUMENT, NOR ANY PART THEREOF, MAY BE USED, REPRODUCED OR MODIFIED IN ANY MANNER WITHOUT THE WRITTEN CONSENT OF CONTECH.



MWS-L-4-8-V-UG
STORMWATER BIOFILTRATION SYSTEM
STANDARD DETAIL

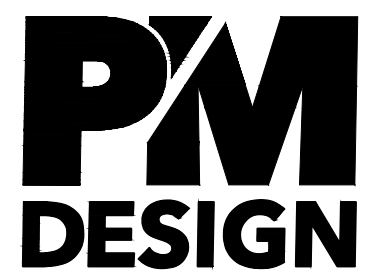

211 GATEWAY RD W
SUITE 208
NAPA, CA 94558
CONTACT: CHET RUSIT
PHONE: 707.475.5670
EMAIL: CRUSIT@PMDC.COM
JEFF LIEDERMAN, ARCHITECT
PM DESIGN GROUP, INC.



CONSULTANT:



© 2026 KIMLEY-HORN AND ASSOCIATES, INC.
1201 Third Ave.
Suite 2800
Seattle, WA 98101
CONTACT:
LIZ WILLMOT, P.E.
(206) 677-8610
LIZ.WILLMOT@KIMLEY-HORN.COM



PROTOTYPE P4E-AV
SCHEME
VERSION 2025-1.0
RAISING CANE'S
RESTAURANT NO.: #C1360
4110 SOUTH MERIDIAN
PUYALLUP, WA 98373

REV	DATE	DESCRIPTION
02/24/26		80% CLIENT REVIEW SET
03/10/26		1ST CITY SUBMITTAL

DRAWN BY:
CHECKED BY:
ARCH. PROJECT NO.:
RAC25014.0
SHEET NAME:
DRAINAGE
DETAILS
SHEET NUMBER:
C5.2

1ST CITY SUBMITTAL : 03/10/26

This document, together with the concepts and designs presented herein, is intended only for the specific purpose and client for which it was prepared. Review of and improper reliance on this document without written authorization and adaptation by Kimley-Horn and Associates, Inc. shall be without liability to Kimley-Horn and Associates, Inc.
 K:\SEA_Civil\090042 - Raising Cane's (PlanSheets)\C5.2--DRAINAGE DETAILS.dwg Mar 10, 2026 2:30pm by: Toyn, Chisholm

B. BMP Details

BMP C105: Stabilized Construction Access

Purpose

Stabilized construction accesses are established to reduce the amount of sediment transported onto paved roads outside the project site by vehicles or equipment. This is done by constructing a stabilized pad of quarry spalls at entrances and exits for project sites.

Conditions of Use

Construction accesses shall be stabilized wherever traffic will be entering or leaving a construction site if paved roads or other paved areas are within 1,000 feet of the site.

For residential subdivision construction sites, provide a stabilized construction access for each residence, rather than only at the main subdivision entrance. Stabilized surfaces shall be of sufficient length/width to provide vehicle access/parking, based on lot size and configuration.

On large commercial, highway, and road projects, the designer should include enough extra materials in the contract to allow for additional stabilized accesses not shown in the initial Construction SWPPP. It is difficult to determine exactly where access to these projects will take place; additional materials will enable the contractor to install them where needed.

Design and Installation Specifications

- See [Figure II-4.1: Stabilized Construction Access](#) for details. Note: the 100' minimum length of the access shall be reduced to the maximum practicable size when the size or configuration of the site does not allow the full length (100').
- Construct stabilized construction accesses with a 12-inch thick pad of 4-inch to 8-inch quarry spalls, a 4-inch course of asphalt treated base (ATB), or use existing pavement. Do not use crushed concrete, cement, or calcium chloride for construction access stabilization because these products raise pH levels in stormwater and concrete discharge to waters of the State is prohibited.
- A separation geotextile shall be placed under the spalls to prevent fine sediment from pumping up into the rock pad. The geotextile shall meet the standards listed in [Table II-4.2: Stabilized Construction Access Geotextile Standards](#).

Table II-4.2: Stabilized Construction Access Geotextile Standards

Geotextile Property	Required Value
---------------------	----------------

Geotextile Property	Required Value
Grab Tensile Strength (ASTM D4751)	200 psi min.
Grab Tensile Elongation (ASTM D4632)	30% max.
Mullen Burst Strength (ASTM D3786-80a)	400 psi min.
AOS (ASTM D4751)	No. 20 to No. 45 (U.S. standard sieve size)

- Consider early installation of the first lift of asphalt in areas that will be paved; this can be used as a stabilized access. Also consider the installation of excess concrete as a stabilized access. During large concrete pours, excess concrete is often available for this purpose.
- Fencing (see [BMP C103: High-Visibility Fence](#)) shall be installed as necessary to restrict traffic to the construction access.
- Whenever possible, the access shall be constructed on a firm, compacted subgrade. This can substantially increase the effectiveness of the pad and reduce the need for maintenance.
- Construction accesses should avoid crossing existing sidewalks and back of walk drains if at all possible. If a construction access must cross a sidewalk or back of walk drain, the full length of the sidewalk and back of walk drain must be covered and protected from sediment leaving the site.

Alternative Material Specification

WSDOT has raised safety concerns about the quarry spall rock specified above. WSDOT observes that the 4-inch to 8-inch rock sizes can become trapped between dually truck tires, and then released off-site at highway speeds. WSDOT has chosen to use a modified specification for the rock while continuously verifying that the stabilized construction access remains effective. To remain effective, the BMP must prevent sediment from migrating off site. To date, there has been no performance testing to verify operation of this new specification. Local jurisdictions may use the alternative specification, but must perform increased off-site inspection if they use, or allow others to use, it.

Stabilized construction accesses may use material that meets the requirements of WSDOT's *Standard Specifications for Road, Bridge, and Municipal Construction* Section 9-03.9(1) ([WSDOT, 2016](#)) for ballast except for the following special requirements.

The grading and quality requirements are listed in [Table II-4.3: Stabilized Construction Access Alternative Material Requirements](#).

Table II-4.3: Stabilized Construction Access Alternative Material Requirements

Sieve Size	Percent Passing
2½"	99 to 100
2"	65 to 100

Sieve Size	Percent Passing
¾"	40 to 80
No. 4	5 max.
No. 100	0 to 2
% Fracture	75 min.
<p>Notes:</p> <ol style="list-style-type: none"> 1. All percentages are by weight. 2. The sand equivalent value and dust ratio requirements do not apply. 3. The fracture requirement shall be at least one fractured face and will apply the combined aggregate retained on the No. 4 sieve in accordance with FOP for AASHTO T 335. 	

Maintenance Standards

Quarry spalls shall be added if the pad is no longer in accordance with the specifications.

- If the access is not preventing sediment from being tracked onto pavement, then alternative measures to keep the streets free of sediment shall be used. This may include replacement/cleaning of the existing quarry spalls, street sweeping, an increase in the dimensions of the access, or the installation of [BMP C106: Wheel Wash](#).
- Any sediment that is tracked onto pavement shall be removed by shoveling or street sweeping. The sediment collected by sweeping shall be removed or stabilized on site. The pavement shall not be cleaned by washing down the street, except when sweeping is ineffective and there is a threat to public safety. If it is necessary to wash the streets, the construction of a small sump to contain the wash water shall be considered. The sediment would then be washed into the sump where it can be controlled.
- Perform street sweeping by hand or with a high efficiency sweeper. Do not use a non-high efficiency mechanical sweeper because this creates dust and throws soils into storm systems or conveyance ditches.
- Any quarry spalls that are loosened from the pad, which end up on the roadway shall be removed immediately.
- If vehicles are entering or exiting the site at points other than the construction access(es), [BMP C103: High-Visibility Fence](#) shall be installed to control traffic.
- Upon project completion and site stabilization, all construction accesses intended as permanent access for maintenance shall be permanently stabilized.

Existing Road

Install driveway
culvert if there is a
roadside ditch present

4" - 8" quarry
spalls

Geotextile

100' min.

Notes:

1. Driveway shall meet the requirements of the permitting agency.
2. It is recommended that the access be crowned so that runoff drains off the pad.

12" minimum thickness

15' min.

Provide full width
of ingress/egress
area



DEPARTMENT OF
ECOLOGY
State of Washington

Stabilized Construction Access

Figure II-4.1: Stabilized Construction Access



[Download PDF](#)

Approved as Functionally Equivalent

Ecology has approved products as able to meet the requirements of this BMP. The products did not pass through the Technology Assessment Protocol – Ecology (TAPE) process. Local jurisdictions may choose not to accept these products, or may require additional testing prior to consideration for local use. Products that Ecology has approved as functionally equivalent are available for review on Ecology’s website at:

<https://ecology.wa.gov/Regulations-Permits/Guidance-technical-assistance/Stormwater-permittee-guidance-resources/Emerging-stormwater-treatment-technologies>

Washington State Department of Ecology

2024 Stormwater Management Manual for Western Washington (2024 SWMMWW)

Publication No. 24-10-013

BMP C120: Temporary and Permanent Seeding

Purpose

Seeding reduces erosion by stabilizing exposed soils. A well-established vegetative cover is one of the most effective methods of reducing erosion.

Conditions of Use

- Use seeding throughout the project on disturbed areas that have reached final grade or that will remain unworked for more than 30 days. See [II-2.5 Element 5: Stabilize Soils](#) for specific timelines for stabilizing exposed soils.
- See [Table II-4.4: Seeding Windows in Western Washington \(continued\)](#) for appropriate seeding windows.
- Review all disturbed areas in late August to early September and complete all seeding by the end of September. Otherwise, vegetation will not establish itself enough to provide more than average protection.
- Mulch is required at all times for seeding because it protects seeds from heat, moisture loss, and transport due to runoff. Mulch can be applied on top of the seed or simultaneously by hydroseeding. See [BMP C121: Mulching](#) for specifications.
- Seed and mulch all disturbed areas not otherwise vegetated at final site stabilization. Final stabilization means the completion of all soil disturbing activities at the site and the establishment of a permanent vegetative cover, or equivalent permanent stabilization measures (such as pavement, riprap, gabions, or geotextiles) which will prevent erosion. See [BMP T5.13: Post-Construction Soil Quality and Depth](#).

Table II-4.4: Seeding Windows in Western Washington

Month	Seeding Recommendations
January	Seeding requires a cover of mulch or an erosion control blanket until 75% grass cover is established
February	
March	

Table II-4.4: Seeding Windows in Western Washington (continued)

Month	Seeding Recommendations
April	Optimum seeding window
May	
June	
July	Seeding requires irrigation until 75% grass cover is established
August	
September	Optimum seeding window
October	Seeding requires a cover of mulch or an erosion control blanket until 75 percent grass cover is established
November	
December	

Design and Installation Specifications

General

- Install channels intended for vegetation before starting major earthwork and hydroseed with a Bonded Fiber Matrix (BFM). For vegetated channels that will have high flows, install erosion control blankets over the top of hydroseed. Before allowing water to flow in vegetated channels, establish a 75% vegetation cover. If vegetated channels cannot be established by seed before water flow, install sod or prevegetated mats in the channel bottom over top of hydromulch and erosion control blankets.
- Confirm the installation of all required stormwater control measures to prevent seed from washing away.
- Hydroseed applications shall include a minimum of 1,500 pounds per acre (lb/acre) of mulch with 3% tackifier. See [BMP C121: Mulching](#) for specifications.
- Areas that will have seeding only, and not landscaping, may need compost or meal-based mulch included in the hydroseed in order to establish vegetation. Re-install native topsoil on the disturbed soil surface before application. See [BMP T5.13: Post-Construction Soil Quality and Depth](#).
- When installing seed via hydroseeding operations, only about 1/3 of the seed actually ends up in contact with the soil surface. This reduces the ability to establish a good stand of grass quickly. To overcome this, consider increasing seed quantities by up to 50 percent.
- Vegetation establishment can be enhanced by one of the following two approaches:
 - Approach 1: Enhance vegetation establishment by dividing the hydromulch operation into two phases:

- Phase 1 – Install all seed and fertilizer with 25% to 30% mulch and tackifier onto the soil in the first lift.
 - Phase 2 – Install the remaining mulch and tackifier over the first lift.
- Approach 2: Vegetation can also be enhanced by:
 - Installing the mulch, seed, fertilizer, and tackifier in one lift;
 - Spreading or blowing straw over the top of the hydromulch at a rate of about 800 to 1,000 lb/acre; or
 - Holding straw in place with a standard tackifier.

Both of these approaches (Approach 1 and Approach 2) will increase cost moderately but will greatly improve and enhance vegetative establishment. The increased cost may be offset by the reduced need for:

- Irrigation,
- Reapplication of mulch, and
- Repair of failed slope surfaces.

Either of these approaches can use standard hydromulch (1,500 lb/acre minimum) and BFM/mechanically bonded fiber matrix (MBFM) (3,000 lb/acre minimum).

- Seed may be installed by hand if it is:
 - Temporary and covered by straw, mulch, or topsoil; or
 - Permanent in small areas (usually less than 1 acre) and covered with mulch, topsoil, or erosion blankets.
- Consult the local suppliers and/or the local conservation district for their recommendations for appropriate seed mixes and application rates. The appropriate mix depends on a variety of factors, including location, exposure, soil type, slope, and expected foot traffic.
- In addition to meeting erosion control functions and not hindering maintenance operations, selection of long-lived, successional growth native vegetation that can compete against or exclude weeds and grow with minimal maintenance after plant establishment is preferred. Provide diversity to the greatest extent possible and plan for a succession of flowering times to improve pollinator habitat.
- The seed mixes listed in [Table II-4.5: Temporary and Permanent Seed Mixes for Western Washington \(continued\)](#) include recommended mixes for both temporary and permanent seeding. Alternative seed mixes approved by the local jurisdiction may also be used.
- Apply the mixes in [Table II-4.5: Temporary and Permanent Seed Mixes for Western Washington \(continued\)](#), with the exception of the wet area seed mix, at a rate of 120 pounds per acre. This rate can be reduced if soil amendments or slow-release fertilizers are used. Apply the wet area seed mix at a rate of 60 pounds per acre.

Table II-4.5: Temporary and Permanent Seed Mixes for Western Washington

Common Name	Latin Name	% Weight	% Purity	% Germination
Temporary Erosion Control Seed Mix				
A standard mix for areas requiring a temporary vegetative cover.				
Chewings or annual blue grass	<i>Festuca rubra</i> var. <i>commutata</i> or <i>Poa anna</i>	40	98	90
Perennial rye	<i>Lolium perenne</i>	50	98	90
Redtop or colonial bentgrass	<i>Agrostis alba</i> or <i>Agrostis tenuis</i>	5	92	85
White dutch clover	<i>Trifolium repens</i>	5	98	90
Landscaping Seed Mix				
A recommended mix for landscaping seed.				
Perennial rye blend	<i>Lolium perenne</i>	70	98	90
Chewings and red fescue blend	<i>Festuca rubra</i> var. <i>commutata</i> or <i>Festuca rubra</i>	30	98	90
Low-Growing Turf Seed Mix				
A turf seed mix for dry situations where there is no need for watering. This mix requires very little maintenance.				
Dwarf tall fescue (several varieties)	<i>Festuca arundinacea</i> var.	45	98	90
Dwarf perennial rye (Barclay)	<i>Lolium perenne</i> var. <i>barclay</i>	30	98	90
Red fescue	<i>Festuca rubra</i>	20	98	90
Colonial bentgrass	<i>Agrostis tenuis</i>	5	98	90
Bioswale Seed Mix				
A seed mix for bioswales and other intermittently wet areas.				
Tall or meadow fescue	<i>Festuca arundinacea</i> or <i>Festuca elatior</i>	75-80	98	90
Seaside/Creeping bentgrass	<i>Agrostis palustris</i>	10-15	92	85
Redtop bentgrass	<i>Agrostis alba</i> or <i>Agrostis gigantea</i>	5-10	90	80
Wet Area Seed Mix				

Table II-4.5: Temporary and Permanent Seed Mixes for Western Washington (continued)

Common Name	Latin Name	% Weight	% Purity	% Germination
A low-growing, relatively non-invasive seed mix appropriate for very wet areas that are not regulated wetlands. Consult Hydraulic Permit Authority (HPA) for seed mixes if applicable.				
Tall or meadow fescue	<i>Festuca arundinacea</i> or <i>Festuca elatior</i>	60-70	98	90
Seaside/Creeping bentgrass	<i>Agrostis palustris</i>	10-15	98	85
Meadow foxtail	<i>Alepocurus pratensis</i>	10-15	90	80
Alsike clover	<i>Trifolium hybridum</i>	1-6	98	90
Redtop bentgrass	<i>Agrostis alba</i>	1-6	92	85
Meadow Seed Mix				
A recommended meadow seed mix for infrequently maintained areas or non-maintained areas where colonization by native plants is desirable. Likely applications include rural road and utility right-of-way. Seeding should take place in September or very early October in order to obtain adequate establishment prior to the winter months. Consider the appropriateness of clover, a fairly invasive species, in the mix. Amending the soil can reduce the need for clover.				
Redtop or Oregon bentgrass	<i>Agrostis alba</i> or <i>Agrostis oregonensis</i>	20	92	85
Red fescue	<i>Festuca rubra</i>	70	98	90
White dutch clover	<i>Trifolium repens</i>	10	98	90

Roughening and Rototilling

- The seedbed should be firm and rough. Roughen all soil no matter what the slope. Track walk slopes before seeding if engineering purposes require compaction. Backblading or smoothing of slopes greater than 4H:1V is not allowed if they are to be seeded.
- Restoration-based landscape practices require deeper incorporation than that provided by a simple, single-pass rototilling treatment. Wherever practical, initially rip the subgrade to improve long-term permeability, infiltration, and water inflow qualities. At a minimum, permanent areas shall receive soil amendments to achieve organic matter and permeability performance defined in engineered soil/landscape systems. For systems that are deeper than 8 inches, complete the rototilling process in multiple lifts, or prepare the soil amendments per the specifications and place to achieve the specified depth.

Fertilizers

- Conducting soil tests to determine the exact type and quantity of fertilizer needed is recommended. This will prevent the overapplication of fertilizer.
- Organic matter is the most appropriate form of fertilizer because it provides nutrients (including nitrogen, phosphorus, and potassium) in the least water-soluble form.
- In general, use 10-4-6 N-P-K (nitrogen-phosphorus-potassium) fertilizer at a rate of 90 pounds per acre.
- Always use slow-release fertilizers because they are more efficient and have fewer environmental impacts. Do not add fertilizer to the hydromulch machine, or agitate, more than 20 minutes before use. Too much agitation destroys the slow-release coating.
- There are numerous products available to take the place of chemical fertilizers, including several with seaweed extracts that are beneficial to soil microbes and organisms. If 100% cottonseed meal is used as the mulch in hydroseed, chemical fertilizer may not be necessary. Cottonseed meal provides a good source of long-term, slow-release, available nitrogen.

Bonded Fiber Matrix and Mechanically Bonded Fiber Matrix

- On steep slopes, use Bonded Fiber Matrix (BFM) or Mechanically Bonded Fiber Matrix (MBFM) products. Apply BFM/MBFM products at a minimum rate of 3,000 pounds per acre with approximately 10% tackifier. Achieve a minimum of 95% soil coverage during application. Numerous products are available commercially. Most products require 24-36 hours to cure before rainfall, and cannot be installed on wet or saturated soils. Generally, products come in 40-50 pound bags and include all necessary ingredients except for seed and fertilizer.
- Install products per manufacturer's instructions.
- BFMs and MBFMs provide good alternatives to blankets in most areas requiring vegetation establishment. Advantages over blankets include the following:
 - BFM and MBFMs do not require surface preparation.
 - Helicopters can assist in installing BFM and MBFMs in remote areas.
 - On slopes steeper than 2.5H:1V, blanket installers may require ropes and harnesses for safety.
 - Installing BFM and MBFMs can save at least \$1,000 per acre compared to blankets.

Maintenance Standards

- Reseed any seeded areas that fail to establish at least 75% cover (100% cover for areas that receive sheet or concentrated flows) of all seeded areas after 3 months of active growth following germination during the growing season. If reseeding is ineffective, use an alternate method, such as sodding, mulching, or nets/blankets. If winter weather prevents

adequate grass growth, this time limit may be relaxed at the discretion of the local authority when sensitive areas would otherwise be protected.

- Reseed and protect by mulch any areas that experience erosion after achieving adequate cover. If the erosion problem is drainage related, the problem shall be fixed and the eroded area reseeded and protected by mulch.
- Supply seeded areas with adequate moisture, but do not water to the extent that it causes runoff.

Approved as Functionally Equivalent

Ecology has approved products as able to meet the requirements of this BMP. The products did not pass through the Technology Assessment Protocol – Ecology (TAPE) process. Local jurisdictions may choose not to accept these products, or may require additional testing prior to consideration for local use. Products that Ecology has approved as functionally equivalent are available for review on Ecology's website at:

<https://ecology.wa.gov/Regulations-Permits/Guidance-technical-assistance/Stormwater-permittee-guidance-resources/Emerging-stormwater-treatment-technologies>

BMP C121: Mulching

Purpose

Mulching soils provides immediate temporary protection from erosion. Mulch also enhances plant establishment by conserving moisture, holding fertilizer, seed, and topsoil in place, and moderating soil temperatures. There are a variety of mulches that can be used. This section discusses only the most common types of mulch.

Conditions of Use

As a temporary cover measure, mulch should be used:

- For less than 30 days on disturbed areas that require cover.
- At all times for seeded areas, especially during the wet season and during the hot summer months.
- During the wet season on slopes steeper than 3H:1V with more than 10 feet of vertical relief.

Mulch may be applied at any time of the year and must be refreshed periodically.

For seeded areas, mulch may be made up of 100 percent:

- Cottonseed meal;
- Fibers made of wood, recycled cellulose, hemp, or kenaf;

- Compost;
- Or blends of these.

Tackifier shall be plant-based, such as guar or alpha plantago, or chemical-based such as polyacrylamide or polymers.

Generally, mulches come in 40-50 pound bags. Seed and fertilizer are added at time of application.

Recycled cellulose may contain polychlorinated biphenyl (PCBs). Ecology recommends that products should be evaluated for PCBs prior to use.

Refer to [BMP C126: Polyacrylamide \(PAM\) for Soil Erosion Protection](#) for conditions of use. PAM shall not be directly applied to water or allowed to enter a water body.

Any mulch or tackifier product used shall be installed per the manufacturer’s instructions.

Design and Installation Specifications

For mulch materials, application rates, and specifications, see [Table II-4.7: Mulch Standards and Guidelines \(continued\)](#). Consult with the local supplier or the local conservation district for their recommendations. Increase the application rate until the ground is 95% covered (i.e. not visible under the mulch layer). Note: Thickness may be increased for disturbed areas in or near sensitive areas or other areas highly susceptible to erosion.

Where the option of “Compost” is selected, it should be a coarse compost that meets the size gradations listed in [Table II-4.6: Size Gradations of Compost as Mulch Material](#) when tested in accordance with Test Method 02.02-B found in *Test Methods for the Examination of Composting and Compost* ([Thompson, 2001](#)).

Mulch used within the ordinary high-water mark of surface waters should be selected to minimize potential flotation of organic matter. Composted organic materials have higher specific gravities (densities) than straw, wood, or chipped material. Consult the Hydraulic Permit Authority (HPA) for mulch mixes if applicable.

Table II-4.6: Size Gradations of Compost as Mulch Material

Sieve Size	Percent Passing
3"	100%
1"	90% - 100%
3/4"	70% - 100%
1/4"	40% - 100%

Table II-4.7: Mulch Standards and Guidelines

Mulch Material	Guideline	Description
Straw	Quality Stand-	Air-dried; free from undesirable seed and coarse material.

Table II-4.7: Mulch Standards and Guidelines (continued)

Mulch Material	Guideline	Description
	ards	
	Application Rates	2" to 3" thick; 5 bales per 1,000 sf or 2 to 3 tons per acre
	Remarks	Cost-effective protection when applied with adequate thickness. Hand-application generally requires greater thickness than blown straw. The thickness of straw may be reduced by half when used in conjunction with seeding. In windy areas, straw must be held in place by crimping, using a tackifier, or covering with netting. Blown straw always has to be held in place with a tackifier because even light winds will blow it away. Straw, however, has several deficiencies that should be considered when selecting mulch materials. It often introduces and/or encourages the propagation of weed species, and it has no significant long-term benefits. Straw should only be used if mulches with long-term benefits are unavailable locally. It should also not be used within the ordinary high-water elevation of surface waters (due to flotation).
Hydromulch	Quality Standards	No growth inhibiting factors.
	Application Rates	Approx. 35-45 lbs per 1,000 sf or 1,500 - 2,000 lbs per acre
	Remarks	Shall be applied with hydromulcher. Shall not be used without seed and tackifier unless the application rate is at least doubled. Fibers longer than about 3/4 - 1 inch clog hydromulch equipment. Fibers should be kept to less than 3/4 inch.
Compost	Quality Standards	No visible water or dust during handling. Must be produced per WAC 173-350 , Solid Waste Handling Standards, but may have up to 35% biosolids.
	Application Rates	2" thick minimum; approximately 100 tons per acre (approximately 750 lbs per cubic yard)
	Remarks	More effective control can be obtained by increasing thickness to 3". Compost makes an excellent mulch for protecting final grades until landscaping because it can be directly seeded or tilled into soil as an amendment. Compost used for mulch has a coarser size gradation than compost used for BMP C125: Topsoiling / Composting or BMP T5.13: Post-Construction Soil Quality and Depth . It is more stable and practical to use in wet areas and during rainy weather conditions. Do not use compost near wetlands if biosolids are included. Do not use compost near phosphorous impaired water bodies.
Chipped Site Vegetation	Quality Standards	Gradations from fines to 6 inches in length for texture, variation, and interlocking properties. Include a mix of various sizes so that the

Table II-4.7: Mulch Standards and Guidelines (continued)

Mulch Material	Guideline	Description
		average size is between 2 and 4 inches.
	Application Rates	2" thick minimum.
	Remarks	<p>This is a cost-effective way to dispose of debris from clearing and grubbing, and it eliminates the problems associated with burning. Generally, it should not be used on slopes above approximately 10% because of its tendency to be transported by runoff. It is not recommended within 200 feet of surface waters. If permanent seeding or planting is expected shortly after mulch, the decomposition of the chipped vegetation may tie up nutrients important to grass establishment.</p> <p>Note: Thick application of this material over existing grass, herbaceous species, and some groundcovers could smother and kill vegetation.</p>
Wood-Based Mulch	Quality Standards	No visible water or dust during handling. Must be purchased from a supplier with a Solid Waste Handling Permit or one exempt from solid waste regulations.
	Application Rates	2" thick minimum; approximately 100 tons per acre (approximately 750 lbs. per cubic yard).
	Remarks	This material is often called "wood straw" or "hog fuel". The use of mulch ultimately improves the organic matter in the soil. Special caution is advised regarding the source and composition of wood-based mulches. Its preparation typically does not provide any weed seed control, so evidence of residual vegetation in its composition or known inclusion of weed plants or seeds should be monitored and prevented (or minimized).
Wood Strand Mulch	Quality Standards	A blend of loose, long, thin wood pieces derived from native conifer or deciduous trees with high length-to-width ratio.
	Application Rates	2" thick minimum.
	Remarks	Cost-effective protection when applied with adequate thickness. A minimum of 95% of the wood strand shall have lengths between 2 and 10 inches, with a width and thickness between 1/16 and 0.5 inches. The mulch shall not contain resin, tannin, or other compounds in quantities that would be detrimental to plant life. Sawdust or wood shavings shall not be used as mulch. See specification 9-14.4(4) from the <i>Standard Specifications for Road, Bridge, and Municipal Construction</i> (WSDOT, 2016)

Maintenance Standards

The thickness of the mulch cover must be maintained.

Any areas that experience erosion shall be remulched and/or protected with a net or blanket. If the erosion problem is drainage related, then the problem shall be fixed and the eroded area remulched.

BMP C122: Nets and Blankets

Purpose

Erosion control nets and blankets are intended to prevent erosion and hold seed and mulch in place on steep slopes and in channels so that vegetation can become well established. In addition, some nets and blankets can be used to permanently reinforce turf to protect drainage systems during high flows.

Nets (commonly called matting) are strands of material woven into an open, but high-tensile strength net (e.g. coconut fiber matting). Blankets are strands of material that are not tightly woven, but instead form a layer of interlocking fibers, typically held together by a biodegradable or photodegradable netting (for example, excelsior or straw blankets). They generally have lower tensile strength than nets, but cover the ground more completely. Coir (coconut fiber) fabric comes as both nets and blankets.

Conditions of Use

Erosion control netting and blankets shall be made of natural plant fibers unaltered by synthetic materials.

Erosion control nets and blankets should be used:

- To aid permanent vegetated stabilization of slopes 2H:1V or greater and with more than 10 feet of vertical relief.
- For drainage ditches and swales (highly recommended). The application of appropriate netting or blanket to drainage ditches and swales can protect bare soil from channelized runoff while vegetation is established. Nets and blankets also can capture a great deal of sediment due to their open, porous structure. Nets and blankets can be used to permanently stabilize channels and may provide a cost-effective, environmentally preferable alternative to riprap.

Disadvantages of nets and blankets include:

- Surface preparation is required.
- On slopes steeper than 2.5H:1V, net and blanket installers may need to be roped and harnessed for safety.
- They cost at least \$4,000 - \$6,000 per acre installed.

Advantages of nets and blankets include:

- Installation without mobilizing special equipment.
- Installation by anyone with minimal training

- Installation in stages or phases as the project progresses.
- Installers can hand place seed and fertilizer as they progress down the slope.
- Installation in any weather.
- There are numerous types of nets and blankets that can be designed with various parameters in mind. Those parameters include: fiber blend, mesh strength, longevity, biodegradability, cost, and availability.

An alternative to nets and blankets in some limited conditions is [BMP C202: Riprap Channel Lining](#). Ensure that [BMP C202: Riprap Channel Lining](#) is appropriate before using it as a substitute for nets and blankets.

Design and Installation Specifications

- See [Figure II-4.3: Channel Installation \(Clackamas County et al., 2008\)](#) and [Figure II-4.4: Slope Installation](#) for typical orientation and installation of nets and blankets used in channels and as slope protection. Note: these are typical only; all nets and blankets must be installed per manufacturer's installation instructions.
- Installation is critical to the effectiveness of these products. If good ground contact is not achieved, runoff can concentrate under the product, resulting in significant erosion.
- Install nets and blankets on slopes per the following steps:

1. Complete final grade and track walk up and down the slope. Soils should be raked and uniform prior to installing nets or blankets. To be effective, nets and blankets must have good adhesion to the soil.
2. Install hydromulch with seed and fertilizer.
3. Dig a small trench, approximately 12 inches wide by 6 inches deep along the top of the slope.
4. Install the leading edge of the net/blanket into the small trench and staple approximately every 18 inches.

NOTE: Staples are metal, "U"-shaped, and a minimum of 6 inches long. Longer staples are used in sandy soils. Biodegradable stakes are also available.

5. Roll the net/blanket slowly down the slope as the installer walks backward.

NOTE: The net/blanket rests against the installer's legs. Staples are installed as the net/blanket is unrolled. It is critical that the proper staple pattern is used for the net/blanket being installed. The net/blanket is not to be allowed to roll down the slope on its own as this stretches the net/blanket, making it impossible to maintain soil contact. In addition, no one is allowed to walk on the net/blanket after it is in place.

6. If the net/blanket is not long enough to cover the entire slope length, the trailing edge of the upper net/blanket should overlap the leading edge of the lower net/blanket and be stapled. On steeper slopes, this overlap should be installed in a small trench, stapled, and covered with soil.

- With the variety of products available, it is impossible to cover all the details of appropriate use and installation. Therefore, it is critical that the designer consult the manufacturer's information and that a site visit takes place in order to ensure that the product specified is appropriate. Information is also available in WSDOT's *Standard Specifications for Road, Bridge, and Municipal Construction* Division 8-01 and Division 9-14 ([WSDOT, 2016](#)).
- Use jute matting in conjunction with mulch ([BMP C121: Mulching](#)). Excelsior, woven straw blankets and coir (coconut fiber) blankets may be installed without mulch. There are many other types of erosion control nets and blankets on the market that may be appropriate in certain circumstances.
- In general, most nets (e.g., jute matting) require mulch in order to prevent erosion because they have a fairly open structure. Blankets typically do not require mulch because they usually provide complete protection of the surface.
- Extremely steep, unstable, wet, or rocky slopes are often appropriate candidates for use of synthetic blankets, as are riverbanks, beaches and other high-energy environments. If synthetic blankets are used, the soil should be hydromulched first.
- 100 percent biodegradable blankets are available for use in sensitive areas. These organic blankets are usually held together with a paper or fiber mesh and stitching which may last up to a year.
- Most netting used with blankets is photodegradable, meaning it breaks down under sunlight (not UV stabilized). However, this process can take months or years even under bright sun. Once vegetation is established, sunlight does not reach the mesh. It is not uncommon to find non-degraded netting still in place several years after installation. This can be a problem if maintenance requires the use of mowers or ditch cleaning equipment. In addition, birds and small animals can become trapped in the netting.

Maintenance Standards

- Maintain good contact with the ground. Erosion must not occur beneath the net or blanket.
- Repair and staple any areas of the net or blanket that are damaged or not in close contact with the ground.
- Fix and protect eroded areas if erosion occurs due to poorly controlled drainage.

Figure II-4.3: Channel Installation

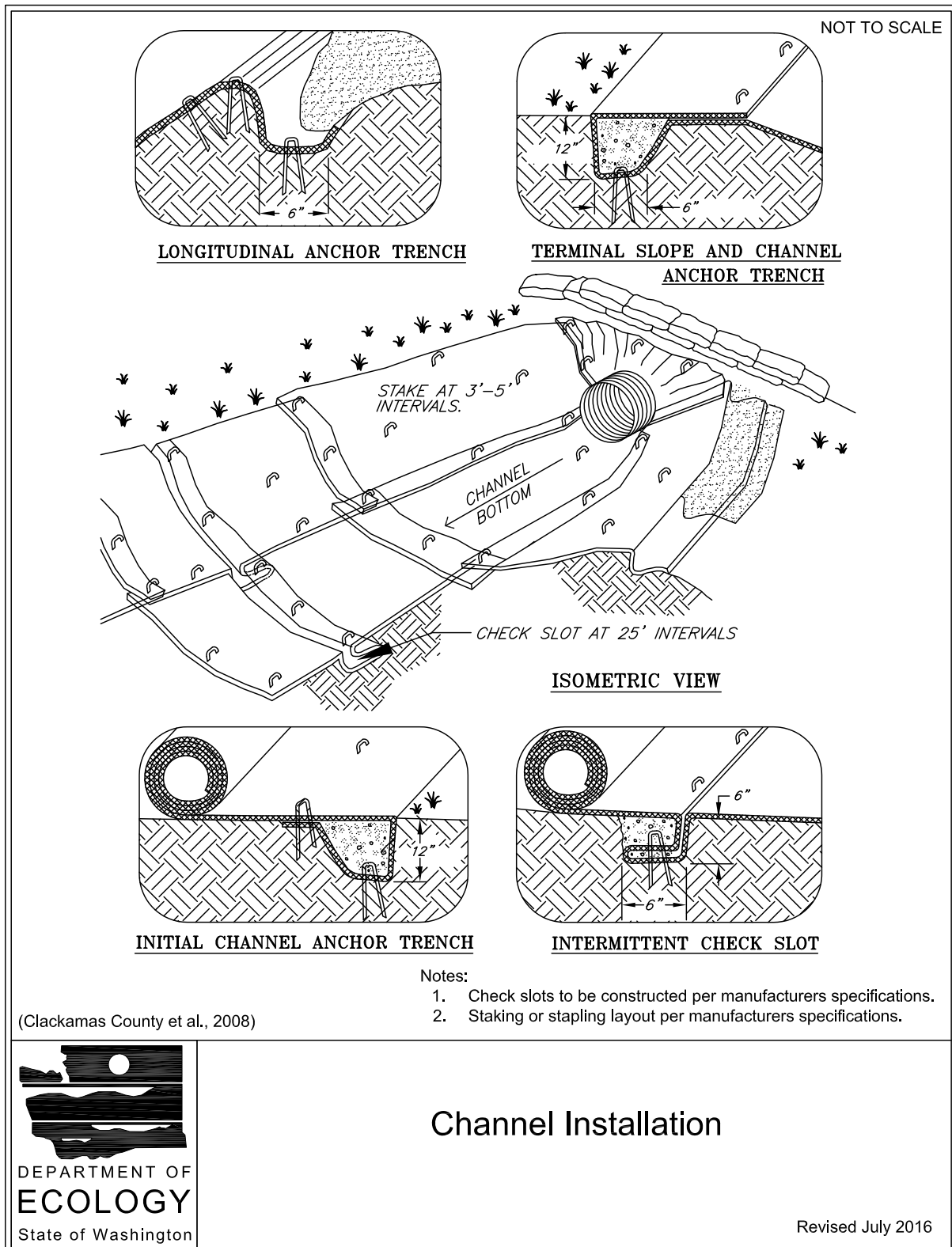
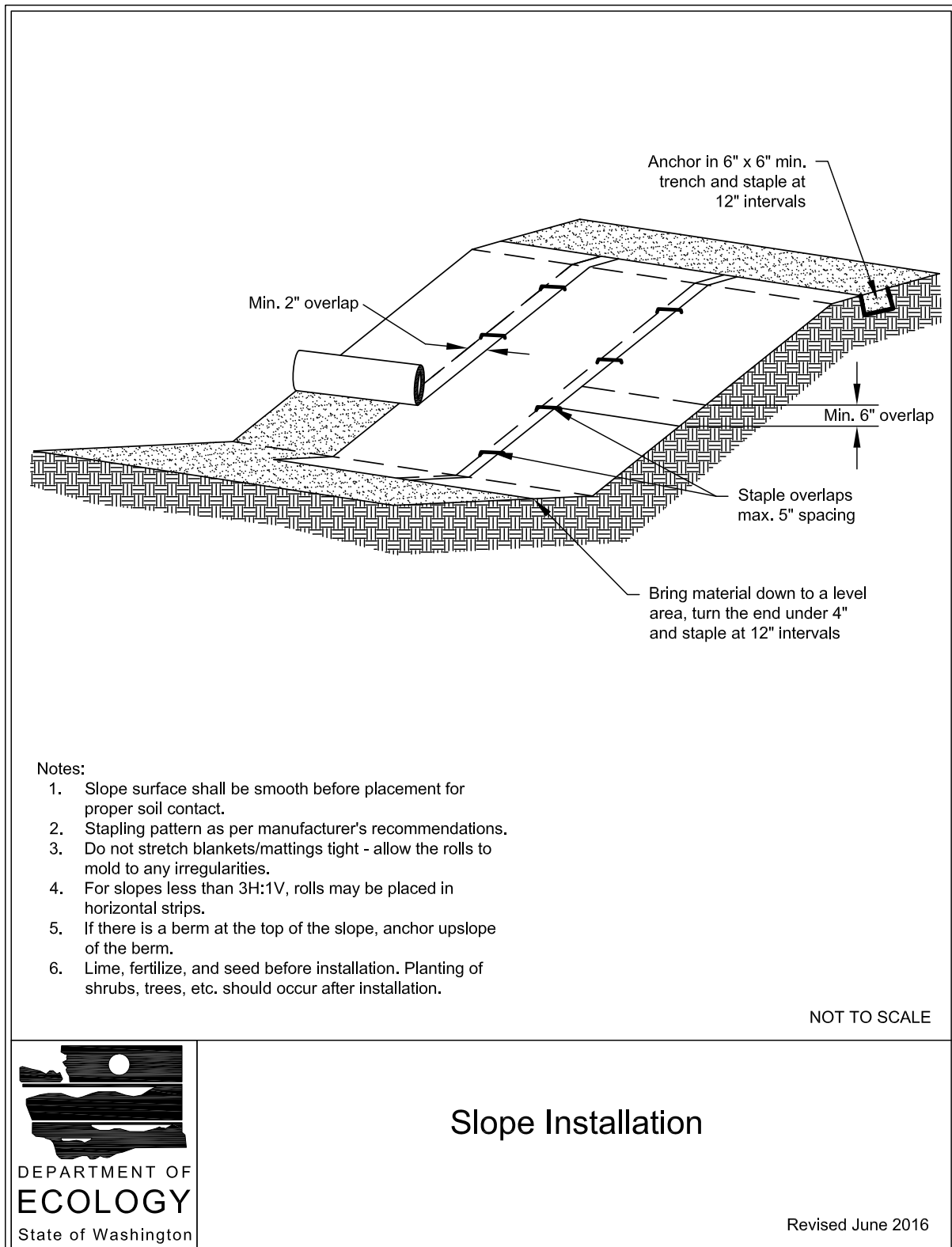

Figure II-4.4: Slope Installation



BMP C123: Plastic Covering

Purpose

Plastic covering provides immediate, short-term erosion protection to slopes and disturbed areas.

Conditions of Use

Plastic covering may be used on disturbed areas that require cover measures for less than 30 days, except as stated below.

- Plastic is particularly useful for protecting cut and fill slopes and stockpiles. However, the relatively rapid breakdown of most polyethylene sheeting makes it unsuitable for applications greater than six months.
- Due to rapid runoff caused by plastic covering, do not use this method upslope of areas that might be adversely impacted by concentrated runoff. Such areas include steep and/or unstable slopes.
- Plastic sheeting may result in increased runoff volumes and velocities, requiring additional on-site measures to counteract the increases. Creating a trough with wattles or other material can convey clean water away from these areas.
- To prevent undercutting, trench and backfill rolled plastic covering products.
- Although the plastic material is inexpensive to purchase, the cost of installation, maintenance, removal, and disposal add to the total costs of this BMP.
- Whenever plastic is used to protect slopes, install water collection measures at the base of the slope. These measures include plastic-covered berms, channels, and pipes used to convey clean rainwater away from bare soil and disturbed areas. Do not mix clean runoff from a plastic covered slope with dirty runoff from a project.
- Other uses for plastic include:
 - Temporary ditch liner.
 - Pond liner in temporary sediment pond.
 - Liner for bermed temporary fuel storage area if plastic is not reactive to the type of fuel being stored.
 - Emergency slope protection during heavy rains.
 - Temporary drainpipe (“elephant trunk”) used to direct water.

Design and Installation Specifications

- Plastic slope cover must be installed as follows:
 1. Run plastic up and down the slope, not across the slope.
 2. Plastic may be installed perpendicular to a slope if the slope length is less than 10 feet.
 3. Provide a minimum of 8-inch overlap at the seams.
 4. On long or wide slopes, or slopes subject to wind, tape all seams.
 5. Place plastic into a small (12-inch wide by 6-inch deep) slot trench at the top of the slope and backfill with soil to keep water from flowing underneath.
 6. Place sand filled burlap or geotextile bags every 3 to 6 feet along seams and tie them together with twine to hold them in place.
 7. Inspect plastic for rips, tears, and open seams regularly and repair immediately. This prevents high velocity runoff from contacting bare soil, which causes extreme erosion.
 8. Sandbags may be lowered into place tied to ropes. However, all sandbags must be staked in place.
- Plastic sheeting shall have a minimum thickness of 6 mil.
- If erosion at the toe of a slope is likely, a gravel berm, riprap, or other suitable protection shall be installed at the toe of the slope in order to reduce the velocity of runoff.

Maintenance Standards

- Torn sheets must be replaced and open seams repaired.
- Completely remove and replace the plastic if it begins to deteriorate due to ultraviolet radiation.
- Completely remove plastic when no longer needed.
- Dispose of old tires used to weight down plastic sheeting appropriately.

Approved as Functionally Equivalent

Ecology has approved products as able to meet the requirements of this BMP. The products did not pass through the Technology Assessment Protocol – Ecology (TAPE) process. Local jurisdictions may choose not to accept these products, or may require additional testing prior to consideration for local use. Products that Ecology has approved as functionally equivalent are available for review on Ecology's website at:

<https://ecology.wa.gov/Regulations-Permits/Guidance-technical-assistance/Stormwater-permittee-guidance-resources/Emerging-stormwater-treatment-technologies>

BMP C140: Dust Control

Purpose

Dust control prevents wind transport of dust from disturbed soil surfaces onto roadways, into drainage systems, and into surface waters.

Conditions of Use

Use dust control in areas (including roadways) subject to surface and air movement of dust where on-site or off-site impacts to roadways, drainage systems, or surface waters are likely.

Design and Installation Specifications

- Vegetate or mulch areas that will not receive vehicle traffic. In areas where planting, mulching, or paving is impractical, apply gravel or landscaping rock.
- Limit dust generation by clearing only those areas where immediate activity will take place, leaving the remaining area(s) in the original condition. Maintain the original ground cover as long as practical.
- Construct natural or artificial windbreaks or windscreens. These may be designed as enclosures for small dust sources.
- Sprinkle the site with water until the surface is wet. Repeat as needed. To prevent carryout of mud onto the street, refer to [BMP C105: Stabilized Construction Access](#) and [BMP C106: Wheel Wash](#).
- Irrigation water can be used for dust control. Irrigation systems should be installed as a first step on sites where dust control is a concern.
- Spray exposed soil areas with a dust palliative, following the manufacturer's instructions and cautions regarding handling and application. Used oil is prohibited from use as a dust suppressant. Local jurisdictions may approve other dust palliatives such as calcium chloride or PAM.
- PAM ([BMP C126: Polyacrylamide \(PAM\) for Soil Erosion Protection](#)) added to water at a rate of 0.5 pounds per 1,000 gallons of water per acre and applied from a water truck is more effective than water alone. This is due to the increased infiltration of water into the soil and reduced evaporation. In addition, small soil particles are bonded together and are not as easily transported by wind. Adding PAM may reduce the quantity of water needed for dust control.

Note that the application rate specified here applies to this BMP, and is not the same application rate that is specified in [BMP C126: Polyacrylamide \(PAM\) for Soil Erosion Protection](#), but the downstream protections still apply.

Refer to [BMP C126: Polyacrylamide \(PAM\) for Soil Erosion Protection](#) for conditions of use. PAM shall not be directly applied to water or allowed to enter a water body. PAM use shall

be reviewed and approved by the local permitting authority and discharge of PAM may be a basis for penalties per [RCW 90.48.080](#).

- Contact your local Air Pollution Control Authority for guidance and training on other dust control measures. Compliance with the local Air Pollution Control Authority constitutes compliance with this BMP. See the following website for more information:

<https://ecology.wa.gov/About-us/Our-role-in-the-community/Partnerships-committees/Clean-air-agencies>

- Use vacuum street sweepers.
- Remove mud and other dirt promptly so it does not dry and then turn into dust.
- Techniques that can be used for unpaved roads and lots include:
 - Lower speed limits. High vehicle speed increases the amount of dust stirred up from unpaved roads and lots.
 - Upgrade the road surface strength by improving particle size, shape, and mineral types that make up the surface and base materials.
 - Add surface gravel to reduce the source of dust emission. Limit the amount of fine particles (those smaller than .075 mm) to 10 to 20 percent.
 - Use geotextile fabrics to increase the strength of new roads or roads undergoing reconstruction.
 - Encourage the use of alternate, paved routes, if available.
 - Apply chemical dust suppressants using the admix method, blending the product with the top few inches of surface material. Suppressants may also be applied as surface treatments.
 - Limit dust-generating work on windy days.
 - Pave unpaved permanent roads and other trafficked areas.

Maintenance Standards

Respray area as necessary to keep dust to a minimum.

Conditions of Use

- Construction projects of any size or type can benefit from having materials on hand. A small commercial development project could have a roll of plastic and some gravel available for immediate protection of bare soil and temporary berm construction. A large earthwork project, such as highway construction, might have several tons of straw, several rolls of plastic, flexible pipe, sandbags, geotextile fabric and steel “T” posts.
- Materials should be stockpiled and readily available before any site clearing, grubbing, or earthwork begins. A large contractor or project proponent could keep a stockpile of materials that are available for use on several projects.
- If storage space at the project site is at a premium, the contractor could maintain the materials at their office or yard. The office or yard must be less than an hour from the project site.

Design and Installation Specifications

Depending on project type, size, complexity, and length, materials and quantities will vary. A good minimum list of items that will cover numerous situations includes:

- Clear plastic, 6 mil
- Drainpipe, 6 or 8 inch diameter
- Sandbags, filled
- Straw bales for mulching
- Quarry spalls
- Washed gravel
- Geotextile fabric
- Catch basin inserts
- Steel "T" posts
- Silt fence material
- Straw wattles

Maintenance Standards

- All materials with the exception of the quarry spalls, steel “T” posts, and gravel should be kept covered and out of both sun and rain.
- Re-stock materials as needed.

BMP C150: Materials on Hand

Purpose

Keep quantities of erosion prevention and sediment control materials on the project site at all times to be used for regular maintenance and emergency situations such as unexpected heavy rains. Having these materials on-site reduces the time needed to replace existing or implement new BMPs when inspections indicate that existing BMPs are not meeting the Construction SWPPP requirements. In addition, contractors can save money by buying some materials in bulk and storing them at their office or yard.

Conditions of Use

- Construction projects of any size or type can benefit from having materials on hand. A small commercial development project could have a roll of plastic and some gravel available for immediate protection of bare soil and temporary berm construction. A large earthwork project, such as highway construction, might have several tons of straw, several rolls of plastic, flexible pipe, sandbags, geotextile fabric and steel “T” posts.
- Materials should be stockpiled and readily available before any site clearing, grubbing, or earthwork begins. A large contractor or project proponent could keep a stockpile of materials that are available for use on several projects.
- If storage space at the project site is at a premium, the contractor could maintain the materials at their office or yard. The office or yard must be less than an hour from the project site.

Design and Installation Specifications

Depending on project type, size, complexity, and length, materials and quantities will vary. A good minimum list of items that will cover numerous situations includes:

- Clear plastic, 6 mil
- Drainpipe, 6 or 8 inch diameter
- Sandbags, filled
- Straw bales for mulching
- Quarry spalls
- Washed gravel
- Geotextile fabric
- Catch basin inserts
- Steel "T" posts
- Silt fence material
- Straw wattles

Maintenance Standards

- All materials with the exception of the quarry spalls, steel “T” posts, and gravel should be kept covered and out of both sun and rain.
- Re-stock materials as needed.

BMP C151: Concrete Handling

Purpose

Concrete work can generate process water and slurry that contain fine particles and high pH, both of which can violate water quality standards in the receiving water. Concrete spillage or concrete discharge to waters of the State is prohibited. Use this BMP to minimize and eliminate concrete, concrete process water, and concrete slurry from entering waters of the State.

Conditions of Use

Any time concrete is used, utilize these management practices. Concrete construction project components include, but are not limited to:

- Curbs
- Sidewalks
- Roads
- Bridges
- Foundations
- Floors
- Runways

Disposal options for concrete, in order of preference are:

1. Off-site disposal
2. Concrete wash-out areas (see [BMP C154: Concrete Washout Area](#))
3. De minimus washout to formed areas awaiting concrete

Design and Installation Specifications

- Wash concrete truck drums at an approved off-site location or in designated concrete washout areas only. Do not wash out concrete trucks onto the ground (including formed areas awaiting concrete), or into storm drains, open ditches, streets, or streams. Refer to [BMP C154: Concrete Washout Area](#) for information on concrete washout areas.
 - Return unused concrete remaining in the truck and pump to the originating batch plant for recycling. Do not dump excess concrete on site, except in designated concrete washout areas as allowed in [BMP C154: Concrete Washout Area](#).
- Wash small concrete handling equipment (e.g. hand tools, screeds, shovels, rakes, floats, trowels, and wheelbarrows) into designated concrete washout areas or into formed areas awaiting concrete pour.

- At no time shall concrete be washed off into the footprint of an area where an infiltration feature will be installed.
- Wash equipment difficult to move, such as concrete paving machines, in areas that do not directly drain to natural or constructed stormwater conveyance or potential infiltration areas.
- Do not allow washwater from areas, such as concrete aggregate driveways, to drain directly (without detention or treatment) to natural or constructed stormwater conveyances.
- Contain washwater and leftover product in a lined container when no designated concrete washout areas (or formed areas, allowed as described above) are available. Dispose of contained concrete and concrete washwater (process water) properly.
- Always use forms or solid barriers for concrete pours, such as pilings, within 15-feet of surface waters.
- Refer to [BMP C252: Treating and Disposing of High pH Water](#) for pH adjustment requirements.
- Refer to the Construction Stormwater General Permit (CSWGP) for pH monitoring requirements if the project involves one of the following activities:
 - Significant concrete work (as defined in the CSWGP).
 - The use of soils amended with (but not limited to) Portland cement-treated base, cement kiln dust or fly ash.
 - Discharging stormwater to segments of water bodies on the 303(d) list (Category 5) for high pH.

Maintenance Standards

Check containers for holes in the liner daily during concrete pours and repair the same day.

BMP C152: Sawcutting and Surfacing Pollution Prevention

Purpose

Sawcutting and surfacing operations generate slurry and process water that contain fine particles and have a high pH (concrete cutting), both of which can violate the water quality standards in the receiving water. Concrete spillage or concrete discharge to waters of the State is prohibited. Use this BMP to minimize and eliminate process water and slurry created by sawcutting or surfacing from entering waters of the State.

Conditions of Use

Utilize these management practices anytime sawcutting or surfacing operations take place. Sawcutting and surfacing operations include, but are not limited to:

- Sawing
- Coring
- Grinding
- Roughening
- Hydro-demolition
- Bridge and road surfacing

Design and Installation Specifications

- Vacuum slurry and cuttings during cutting and surfacing operations.
- Slurry and cuttings shall not remain on permanent concrete or asphalt pavement overnight.
- Slurry and cuttings shall not drain to any natural or constructed drainage conveyance including stormwater systems. This may require temporarily blocking catch basins.
- Dispose of collected slurry and cuttings in a manner that does not violate groundwater or surface water quality standards.
- Do not allow process water generated during hydro-demolition, surface roughening, or similar operations to drain to any natural or constructed drainage conveyance including stormwater systems. Dispose of process water in a manner that does not violate groundwater or surface water quality standards.
- Handle and dispose of cleaning waste material and demolition debris in a manner that does not cause contamination of water. Dispose of sweeping material from a pick-up sweeper at an appropriate disposal site.

Maintenance Standards

Continually monitor operations to determine whether slurry, cuttings, or process water could enter waters of the state. If inspections show that a violation of water quality standards could occur, stop operations and immediately implement preventive measures such as berms, barriers, secondary containment, and/or vacuum trucks.

BMP C153: Material Delivery, Storage, and Containment

Purpose

Prevent, reduce, or eliminate the discharge of pollutants to the stormwater system or water-courses from material delivery and storage. Minimize the storage of hazardous materials on-site, store materials in a designated area, and install secondary containment.

Conditions of Use

Use at construction sites with delivery and storage of the following materials:

- Petroleum products such as fuel, oil and grease
- Soil stabilizers and binders (e.g., polyacrylamide)
- Fertilizers, pesticides, and herbicides
- Detergents
- Asphalt and concrete compounds
- Hazardous chemicals such as acids, lime, adhesives, paints, solvents, and curing compounds
- Any other material that may be detrimental if released to the environment

Design and Installation Specifications

- The temporary storage area should be located away from vehicular traffic, near the construction entrance(s), and away from waterways or storm drains.
- Safety Data Sheets (SDS) should be supplied for all materials stored. Chemicals should be kept in their original labeled containers.
- Hazardous material storage on-site should be minimized.
- Hazardous materials should be handled as infrequently as possible.
- During the wet weather season (October 1 – April 30), consider storing materials in a covered area.
- Materials should be stored in secondary containments, such as an earthen dike, horse trough, or even a children’s wading pool for non-reactive materials such as detergents, oil, grease, and paints. Small amounts of material may be secondarily contained in “bus boy” trays or concrete mixing trays.
- Do not store chemicals, drums, or bagged materials directly on the ground. Place these items on a pallet and, when possible, within secondary containment.
- If drums must be kept uncovered, store them at a slight angle to reduce ponding of rain-water on the lids to reduce corrosion. Domed plastic covers are inexpensive and snap to the top of drums, preventing water from collecting.
- Liquids, petroleum products, and substances listed in 40 CFR Parts 110, 117, or 302 shall be stored in approved containers and drums and shall not be overfilled. Containers and drums shall be stored in temporary secondary containment facilities.
- Temporary secondary containment facilities shall provide for a spill containment volume able to contain 10% of the total enclosed container volume of all containers, or 110% of the capacity of the largest container within its boundary, whichever is greater.

- Secondary containment facilities shall be impervious to the materials stored therein for a minimum contact time of 72 hours.
- Sufficient separation should be provided between stored containers to allow for spill cleanup and emergency response access.
- During the wet weather season (Oct 1 – April 30), each secondary containment facility shall be covered during non-working days.
- Secondary containment facilities shall be covered at all times, except when in active use.
- Keep material storage areas clean, organized, and equipped with an ample supply of appropriate spill clean-up material (spill kit).
- The spill kit should include, at a minimum:
 - 1 - Water resistant nylon bag
 - 3 - Oil absorbent socks 3"x 4'
 - 2 - Oil absorbent socks 3"x 10'
 - 12 - Oil absorbent pads 17"x19"
 - 1 - Pair splash resistant goggles
 - 3 - Pairs nitrile gloves
 - 10 - Disposable bags with ties
 - Instructions

Maintenance Standards

- Secondary containment facilities shall be maintained free of accumulated rainwater and spills. In the event of spills or leaks, accumulated rainwater and spills shall be collected and placed into drums. These liquids shall be handled as hazardous waste unless testing determines them to be non-hazardous.
- Re-stock spill kit materials as needed.

BMP C154: Concrete Washout Area

Purpose

Prevent or reduce the discharge of pollutants from concrete waste to stormwater by conducting washout off-site, or performing on-site washout in a designated area.

Conditions of Use

Concrete washout areas are implemented on construction projects where:

- Concrete is used as a construction material
- It is not possible to dispose of all concrete wastewater and washout off-site (ready mix plant, etc.).
- Concrete truck drums are washed on-site.

Note that auxiliary concrete truck components (e.g. chutes and hoses) and small concrete handling equipment (e.g. hand tools, screeds, shovels, rakes, floats, trowels, and wheelbarrows) may be washed into formed areas awaiting concrete pour.

At no time shall concrete be washed off into the footprint of an area where an infiltration feature will be installed.

Design and Installation Specifications

Implementation

- Perform washout of concrete truck drums at an approved off-site location or in designated concrete washout areas only.
- Do not wash out concrete onto non-formed areas, or into storm drains, open ditches, streets, or streams.
- Wash equipment difficult to move, such as concrete paving machines, in areas that do not directly drain to natural or constructed stormwater conveyance or potential infiltration areas.
- Do not allow excess concrete to be dumped on-site, except in designated concrete washout areas as allowed above.
- Concrete washout areas may be prefabricated concrete washout containers, or self-installed structures (above-grade or below-grade).
- Prefabricated containers are most resistant to damage and protect against spills and leaks. Companies may offer delivery service and provide regular maintenance and disposal of solid and liquid waste.
- If self-installed concrete washout areas are used, below-grade structures are preferred over above-grade structures because they are less prone to spills and leaks.
- Self-installed above-grade structures should only be used if excavation is not practical.
- Concrete washout areas shall be constructed and maintained in sufficient quantity and size to contain all liquid and concrete waste generated by washout operations.

Education

- Discuss the concrete management techniques described in this BMP with the ready-mix concrete supplier before any deliveries are made.
- Educate employees and subcontractors on the concrete waste management techniques described in this BMP.

- Arrange for the contractor's superintendent or Certified Erosion and Sediment Control Lead (CESCL) to oversee and enforce concrete waste management procedures.
- A sign should be installed adjacent to each concrete washout area to inform concrete equipment operators to utilize the proper facilities.

Contracts

Incorporate requirements for concrete waste management into concrete supplier and sub-contractor agreements.

Location and Placement

- Locate concrete washout areas at least 50 feet from sensitive areas such as storm drains, open ditches, water bodies, or wetlands.
- Allow convenient access to the concrete washout area for concrete trucks, preferably near the area where the concrete is being poured.
- If trucks need to leave a paved area to access the concrete washout area, prevent track-out with a pad of rock or quarry spalls (see [BMP C105: Stabilized Construction Access](#)). These areas should be far enough away from other construction traffic to reduce the likelihood of accidental damage and spills.
- The number of concrete washout areas you install should depend on the expected demand for storage capacity.
- On large sites with extensive concrete work, concrete washout areas should be placed in multiple locations for ease of use by concrete truck drivers.

Concrete Truck Washout Procedures

- Washout of concrete truck drums shall be performed in designated concrete washout areas only.
- Concrete washout from concrete pumper bins can be washed into concrete pumper trucks and discharged into designated concrete washout areas or properly disposed of off-site.

Concrete Washout Area Installation

- Concrete washout areas should be constructed as shown in the figures below, with a recommended minimum length and minimum width of 10 ft, but with sufficient quantity and volume to contain all liquid and concrete waste generated by washout operations.
- Plastic lining material should be a minimum of 10 mil polyethylene sheeting and should be free of holes, tears, or other defects that compromise the impermeability of the material.
- Lath and flagging should be commercial type.
- Liner seams shall be installed in accordance with manufacturers' recommendations.

- Soil base shall be prepared free of rocks or other debris that may cause tears or holes in the plastic lining material.

Maintenance Standards

Inspection and Maintenance

- Inspect and verify that concrete washout areas are in place prior to the commencement of concrete work.
- Once concrete wastes are washed into the designated washout area and allowed to harden, the concrete should be broken up, removed, and disposed of per applicable solid waste regulations. Dispose of hardened concrete on a regular basis.
- During periods of concrete work, inspect the concrete washout areas daily to verify continued performance.
 - Check overall condition and performance.
 - Check remaining capacity (% full).
 - If using self-installed concrete washout areas, verify plastic liners are intact and side-walls are not damaged.
 - If using prefabricated containers, check for leaks.
- Maintain the concrete washout areas to provide adequate holding capacity with a minimum freeboard of 12 inches.
- Concrete washout areas must be cleaned, or new concrete washout areas must be constructed and ready for use once the concrete washout area is 75% full.
- If the concrete washout area is nearing capacity, vacuum and dispose of the waste material in an approved manner.
 - Do not discharge liquid or slurry to waterways, storm drains or directly onto ground.
 - Do not discharge to the sanitary sewer without local approval.
 - Place a secure, non-collapsing, non-water collecting cover over the concrete washout area prior to predicted wet weather to prevent accumulation and overflow of precipitation.
 - Remove and dispose of hardened concrete and return the structure to a functional condition. Concrete may be reused on-site or hauled away for disposal or recycling.
- When you remove materials from a self-installed concrete washout area, build a new structure; or, if the previous structure is still intact, inspect for signs of weakening or damage, and make any necessary repairs. Re-line the structure with new plastic after each cleaning.

Removal of Concrete Washout Areas

- When concrete washout areas are no longer required for the work, the hardened concrete, slurries and liquids shall be removed and properly disposed of.
- Materials used to construct concrete washout areas shall be removed from the site of the work and disposed of or recycled.
- Holes, depressions or other ground disturbance caused by the removal of the concrete washout areas shall be backfilled, repaired, and stabilized to prevent erosion.

Figure II-4.8: Concrete Washout Area with Straw Bales

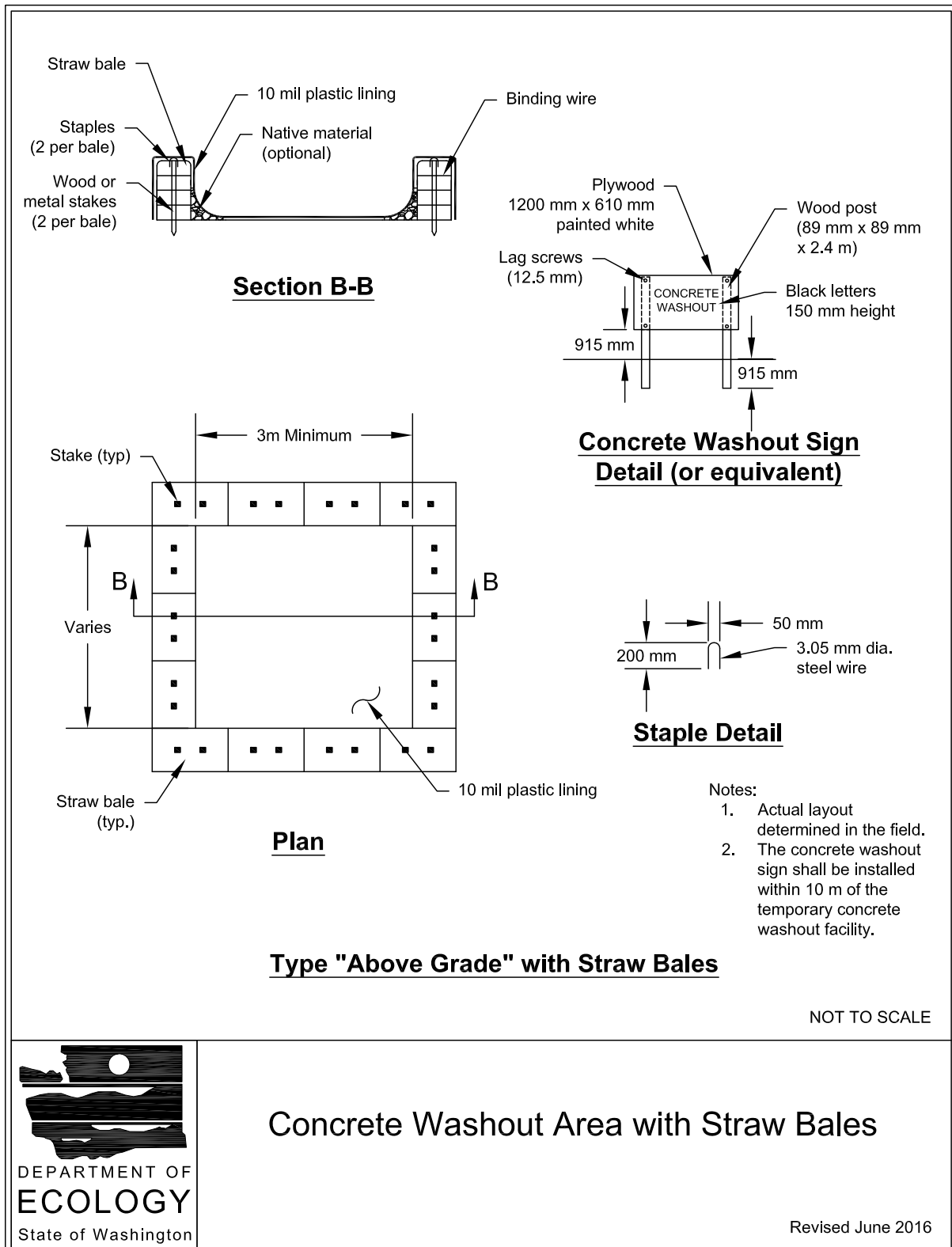

Concrete Washout Area with Straw Bales

Revised June 2016

Figure II-4.9: Prefabricated Concrete Washout Container with Ramp

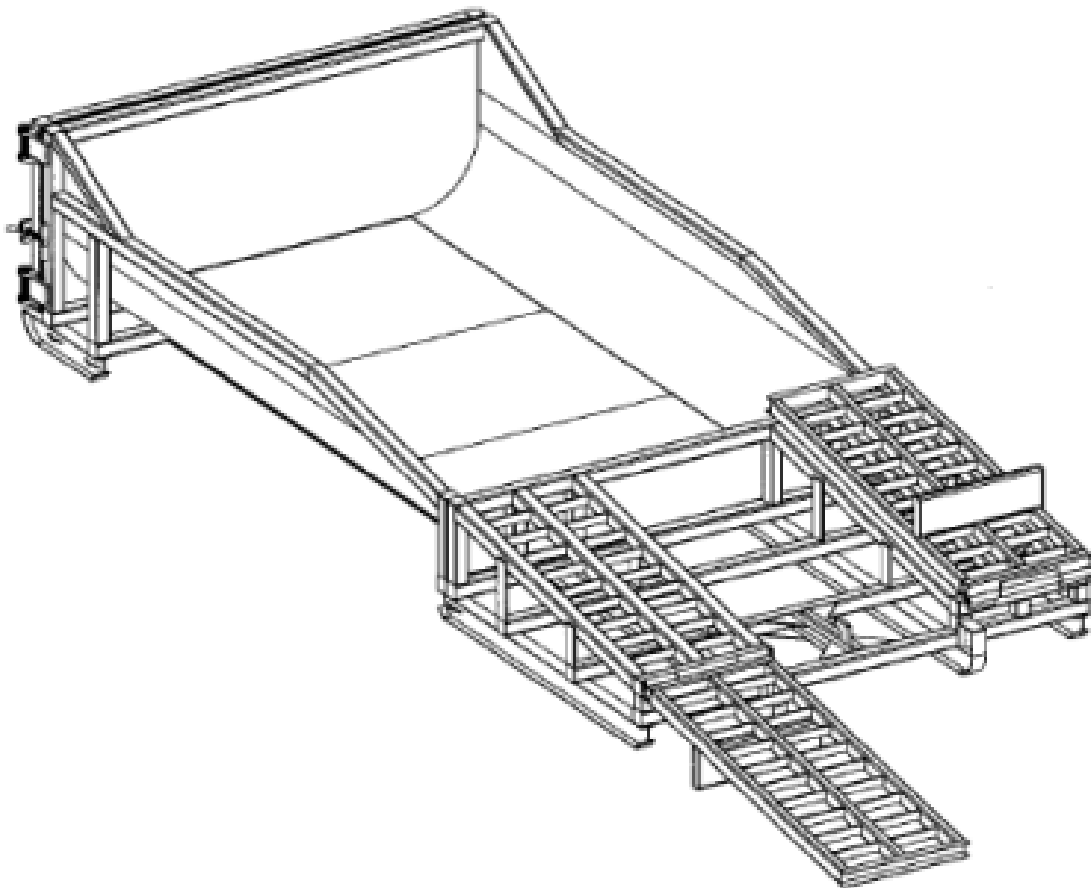

NOT TO SCALE



Prefabricated Concrete Washout Container with Ramp

Revised June 2016

BMP C200: Interceptor Dike and Swale

Purpose

Provide a dike of compacted soil or a swale at the top or base of a disturbed slope or along the perimeter of a disturbed construction area to convey stormwater. Use the dike and/or swale to intercept the runoff from unprotected areas and direct it to areas where erosion can be controlled. This can prevent storm runoff from entering the work area or sediment-laden runoff from leaving the construction site.

Conditions of Use

Use an interceptor dike or swale where runoff from an exposed site or disturbed slope must be conveyed to an erosion control BMP that can safely convey the stormwater.

- Locate upslope of a construction site to prevent runoff from entering the disturbed area.
- When placed horizontally across a disturbed slope, it reduces the amount and velocity of runoff flowing down the slope.
- Locate downslope to collect runoff from a disturbed area and direct it to a sediment trapping BMP (e.g. [BMP C240: Sediment Trap](#) or [BMP C241: Sediment Pond \(Temporary\)](#)).

Design and Installation Specifications

- Dike and/or swale and channel must be stabilized with temporary or permanent vegetation or other channel protection during construction.
- Steep grades require channel protection and check dams.
- Review construction for areas where overtopping may occur.
- Can be used at the top of new fill before vegetation is established.
- May be used as a permanent diversion channel to carry the runoff.
- Contributing area for an individual dike or swale should be one acre or less.
- Design the dike and/or swale to contain flows calculated by one of the following methods:
 - Single Event Hydrograph Method: The peak volumetric flow rate calculated using a 10-minute time step from a Type 1A, 10-year, 24-hour frequency storm for the worst-case land cover condition.

OR

- Continuous Simulation Method: The 10-year peak flow rate, as determined by an approved continuous runoff model with a 15-minute time step for the worst-case land cover condition. Worst-case land cover conditions (i.e. producing the most runoff) should be used for analysis. In most cases, this would be the land cover conditions just prior to final landscaping.

Interceptor Dikes

Interceptor dikes shall meet the following criteria:

- Top Width: 2 feet minimum.
- Height: 1.5 feet minimum on berm.
- Side Slope: 2H:1V or flatter.
- Grade: Depends on topography; however, dike system minimum is 0.5%, and maximum is 1%.
- Compaction: Minimum of 90% ASTM D698 standard proctor.
- Stabilization: Depends on velocity and reach. Inspect regularly to ensure stability.
- Ground Slopes less than 5%: Seed and mulch applied within 5 days of dike construction (see [BMP C121: Mulching](#)).
- Ground Slopes from 5% to 40%: Dependent on runoff velocities and dike materials. Stabilization should be done immediately using either sod or riprap, or other measures to avoid erosion.
- The upslope side of the dike shall provide positive drainage to the dike outlet. No erosion shall occur at the outlet. Provide energy dissipation measures as necessary. Sediment-laden runoff must be released through a sediment trapping BMP.
- Minimize construction traffic over temporary dikes. Use temporary cross culverts for channel crossing.
- See [Table II-4.9: Horizontal Spacing of Interceptor Dikes Along Ground Slope](#) for recommended horizontal spacing between dikes.

Table II-4.9: Horizontal Spacing of Interceptor Dikes Along Ground Slope

Average Slope	Slope Percent	Flowpath Length
20H:1V or less	3 - 5%	300 feet
(10 to 20)H:1V	5 - 10%	200 feet
(4 to 10)H:1V	10 - 25%	100 feet
(2 to 4)H:1V	25 - 50%	50 feet

Interceptor Swales

Interceptor swales shall meet the following criteria:

- Bottom Width: 2 feet minimum; the cross-section bottom shall be level.
- Depth: 1 foot minimum.
- Side Slope: 2H:1V or flatter.
- Grade: Maximum 5%, with positive drainage to a suitable outlet (such as [BMP C241: Sediment Pond \(Temporary\)](#)).
- Stabilization: Seed per [BMP C120: Temporary and Permanent Seeding](#), or [BMP C202: Riprap Channel Lining](#), 12 inches thick riprap pressed into the bank and extending at least 8 inches vertical from the bottom.

Maintenance Standards

- Inspect diversion dikes and interceptor swales once a week and after every rainfall. Immediately remove sediment from the flow area.
- Damage caused by construction traffic or other activity must be repaired before the end of each working day.
- Check outlets and make timely repairs as needed to avoid gully formation. When the area below the temporary diversion dike is permanently stabilized, remove the dike and fill and stabilize the channel to blend with the natural surface.

Washington State Department of Ecology

2024 Stormwater Management Manual for Western Washington (2024 SWMMWW)

Publication No. 24-10-013

BMP C160: Certified Erosion and Sediment Control Lead

Purpose

The project proponent designates at least one person as the responsible representative in charge of erosion and sediment control (ESC) and water quality protection. The designated person shall be responsible for ensuring compliance with all local, state, and federal erosion and sediment control and water quality requirements. Construction sites one acre or larger that discharge to waters of the State must designate a Certified Erosion and Sediment Control Lead (CESCL) as the responsible representative.

Conditions of Use

A CESCL shall be made available on projects one acre or larger that discharge stormwater to surface waters of the state. Sites less than one acre may have a person without CESCL certification conduct inspections.

The CESCL shall:

- Have a current certificate proving attendance in an ESC training course that meets the minimum ESC training and certification requirements established by Ecology.

Ecology has provided the minimum requirements for CESCL course training, as well as a list of ESC training and certification providers at:

<https://ecology.wa.gov/Regulations-Permits/Permits-certifications/Certified-erosion-sediment-control>

OR

- Be a Certified Professional in Erosion and Sediment Control (CPESC). For additional information go to:

<http://www.envirocertintl.org/cpesc/>

Specifications

- CESCL certification shall remain valid for three years.
- The CESCL shall have authority to act on behalf of the contractor or project proponent and shall be available, or on-call, 24 hours per day throughout the period of construction.
- The Construction SWPPP shall include the name, telephone number, fax number, and address of the designated CESCL. See [II-3 Construction Stormwater Pollution Prevention Plans \(Construction SWPPPs\)](#).
- A CESCL may provide inspection and compliance services for multiple construction projects in the same geographic region, but must be on site whenever earthwork activities are occurring that could generate release of turbid water.

- Duties and responsibilities of the CESCL shall include, but are not limited to, the following:
 - Maintaining a permit file on site at all times which includes the Construction SWPPP and any associated permits and plans.
 - Directing BMP installation, inspection, maintenance, modification, and removal.
 - Updating all project drawings and the Construction SWPPP with changes made.
 - Completing any sampling requirements including reporting results using electronic Discharge Monitoring Reports (WebDMR).
 - Facilitating, participating in, and taking corrective actions resulting from inspections performed by outside agencies or the owner.
 - Keeping daily logs and inspection reports. Inspection reports should include:
 - Inspection date/time.
 - Weather information; general conditions during inspection and approximate amount of precipitation since the last inspection.
 - Visual monitoring results, including a description of discharged stormwater. The presence of suspended sediment, turbid water, discoloration, and oil sheen shall be noted, as applicable.
 - Any water quality monitoring performed during inspection.
 - General comments and notes, including a brief description of any BMP repairs, maintenance or installations made as a result of the inspection.
 - A summary or list of all BMPs implemented, including observations of all ESC structures or practices. The following shall be noted:
 1. Locations of BMPs inspected.
 2. Locations of BMPs that need maintenance.
 3. Locations of BMPs that failed to operate as designed or intended.
 4. Locations of where additional or different BMPs are required.

BMP C162: Scheduling

Purpose

Sequencing a construction project can reduce the amount and duration of soil exposed to erosion by wind, rain, runoff, and vehicle tracking.

Conditions of Use

The construction sequence schedule is an orderly listing of all major land-disturbing activities together with the necessary erosion and sediment control (ESC) measures planned for the

project. This type of schedule guides the contractor on work to be done before other work is started so that serious erosion and sedimentation problems can be avoided.

Following a specified work schedule that coordinates the timing of land-disturbing activities and the installation of control measures is perhaps the most cost-effective way of controlling erosion during construction. The removal of ground cover leaves a site vulnerable to erosion. Construction sequencing that limits land clearing, provides timely installation of ESC BMPs, and restores protective cover quickly can significantly reduce the erosion potential of a site.

Design Considerations

- Minimize construction during rainy periods.
- Schedule projects to disturb only small portions of the site at any one time. Complete grading as soon as possible. Immediately stabilize the disturbed portion before grading the next portion. Practice staged seeding in order to revegetate cut and fill slopes as the work progresses.

II-4.3 Construction Runoff BMPs

BMP C200: Interceptor Dike and Swale

Purpose

Provide a dike of compacted soil or a swale at the top or base of a disturbed slope or along the perimeter of a disturbed construction area to convey stormwater. Use the dike and/or swale to intercept the runoff from unprotected areas and direct it to areas where erosion can be controlled. This can prevent storm runoff from entering the work area or sediment-laden runoff from leaving the construction site.

Conditions of Use

Use an interceptor dike or swale where runoff from an exposed site or disturbed slope must be conveyed to an erosion control BMP that can safely convey the stormwater.

- Locate upslope of a construction site to prevent runoff from entering the disturbed area.
- When placed horizontally across a disturbed slope, it reduces the amount and velocity of runoff flowing down the slope.
- Locate downslope to collect runoff from a disturbed area and direct it to a sediment trapping BMP (e.g. [BMP C240: Sediment Trap](#) or [BMP C241: Sediment Pond \(Temporary\)](#)).

Design and Installation Specifications

- Dike and/or swale and channel must be stabilized with temporary or permanent vegetation or other channel protection during construction.
- Steep grades require channel protection and check dams.

- Review construction for areas where overtopping may occur.
- Can be used at the top of new fill before vegetation is established.
- May be used as a permanent diversion channel to carry the runoff.
- Contributing area for an individual dike or swale should be one acre or less.
- Design the dike and/or swale to contain flows calculated by one of the following methods:
 - Single Event Hydrograph Method: The peak volumetric flow rate calculated using a 10-minute time step from a Type 1A, 10-year, 24-hour frequency storm for the worst-case land cover condition.

OR

 - Continuous Simulation Method: The 10-year peak flow rate, as determined by an approved continuous runoff model with a 15-minute time step for the worst-case land cover condition.

Worst-case land cover conditions (i.e. producing the most runoff) should be used for analysis. In most cases, this would be the land cover conditions just prior to final landscaping.

Interceptor Dikes

Interceptor dikes shall meet the following criteria:

- Top Width: 2 feet minimum.
- Height: 1.5 feet minimum on berm.
- Side Slope: 2H:1V or flatter.
- Grade: Depends on topography; however, dike system minimum is 0.5%, and maximum is 1%.
- Compaction: Minimum of 90% ASTM D698 standard proctor.
- Stabilization: Depends on velocity and reach. Inspect regularly to ensure stability.
- Ground Slopes less than 5%: Seed and mulch applied within 5 days of dike construction (see [BMP C121: Mulching](#)).
- Ground Slopes from 5% to 40%: Dependent on runoff velocities and dike materials. Stabilization should be done immediately using either sod or riprap, or other measures to avoid erosion.
- The upslope side of the dike shall provide positive drainage to the dike outlet. No erosion shall occur at the outlet. Provide energy dissipation measures as necessary. Sediment-laden runoff must be released through a sediment trapping BMP.
- Minimize construction traffic over temporary dikes. Use temporary cross culverts for channel crossing.

- See [Table II-4.9: Horizontal Spacing of Interceptor Dikes Along Ground Slope](#) for recommended horizontal spacing between dikes.

Table II-4.9: Horizontal Spacing of Interceptor Dikes Along Ground Slope

Average Slope	Slope Percent	Flowpath Length
20H:1V or less	3 - 5%	300 feet
(10 to 20)H:1V	5 - 10%	200 feet
(4 to 10)H:1V	10 - 25%	100 feet
(2 to 4)H:1V	25 - 50%	50 feet

Interceptor Swales

Interceptor swales shall meet the following criteria:

- Bottom Width: 2 feet minimum; the cross-section bottom shall be level.
- Depth: 1 foot minimum.
- Side Slope: 2H:1V or flatter.
- Grade: Maximum 5%, with positive drainage to a suitable outlet (such as [BMP C241: Sediment Pond \(Temporary\)](#)).
- Stabilization: Seed per [BMP C120: Temporary and Permanent Seeding](#), or [BMP C202: Riprap Channel Lining](#), 12 inches thick riprap pressed into the bank and extending at least 8 inches vertical from the bottom.

Maintenance Standards

- Inspect diversion dikes and interceptor swales once a week and after every rainfall. Immediately remove sediment from the flow area.
- Damage caused by construction traffic or other activity must be repaired before the end of each working day.
- Check outlets and make timely repairs as needed to avoid gully formation. When the area below the temporary diversion dike is permanently stabilized, remove the dike and fill and stabilize the channel to blend with the natural surface.

BMP C220: Inlet Protection

Purpose

Inlet protection prevents coarse sediment from entering drainage systems prior to permanent stabilization of the disturbed area.

Conditions of Use

Use inlet protection at inlets that are operational before permanent stabilization of the disturbed areas that contribute runoff to the inlet. Provide protection for all storm drain inlets downslope and within 500 feet of a disturbed or construction area, unless those inlets are preceded by a sediment trapping BMP.

Also consider inlet protection for lawn and yard drains on new home construction. These small and numerous drains coupled with lack of gutters can add significant amounts of sediment into the roof drain system. If possible, delay installing lawn and yard drains until just before landscaping, or cap these drains to prevent sediment from entering the system until completion of landscaping. Provide 18-inches of sod around each finished lawn and yard drain.

[Table II-4.11: Storm Drain Inlet Protection](#) lists several options for inlet protection. All of the methods for inlet protection tend to plug and require a high frequency of maintenance. Limit contributing drainage areas for an individual inlet to one acre or less. If possible, provide emergency overflows with additional end-of-pipe treatment where stormwater ponding would cause a hazard.

Table II-4.11: Storm Drain Inlet Protection

Type of Inlet Protection	Emergency Overflow	Applicable for Paved / Earthen Surfaces	Conditions of Use
Drop Inlet Protection			
Excavated drop inlet protection	Yes, temporary flooding may occur	Earthen	Applicable for heavy flows. Easy to maintain. Large area requirement: 30'x30'/acre
Block and gravel drop inlet protection	Yes	Paved or Earthen	Applicable for heavy concentrated flows. Will not pond.
Gravel and wire drop inlet protection	No	Paved or Earthen	Applicable for heavy concentrated flows. Will pond. Can withstand traffic.
Catch basin filters	Yes	Paved or Earthen	Frequent maintenance required.
Curb Inlet Protection			
Curb inlet protection with wooden weir	Small capacity overflow	Paved	Used for sturdy, more compact installation.
Block and gravel curb inlet protection	Yes	Paved	Sturdy, but limited filtration.
Culvert Inlet Protection			
Culvert inlet sediment trap	N/A	N/A	18 month expected life.

Design and Installation Specifications

Excavated Drop Inlet Protection

Excavated drop inlet protection consists of an excavated impoundment around the storm drain inlet. Sediment settles out of the stormwater prior to entering the storm drain. Design and installation specifications for excavated drop inlet protection include:

- Provide a depth of 1 to 2 feet as measured from the crest of the inlet structure.
- Side slopes of excavation should be no steeper than 2H:1V.
- Minimum volume of excavation is 35 cubic yards.
- Shape the excavation to fit the site, with the longest dimension oriented toward the longest inflow area.
- Install provisions for draining to prevent standing water.
- Clear the area of all debris.

- Grade the approach to the inlet uniformly.
- Drill weep holes into the side of the inlet.
- Protect weep holes with screen wire and washed aggregate.
- Seal weep holes when removing structure and stabilizing area.
- Build a temporary dike, if necessary, to the down slope side of the structure to prevent bypass flow.

Block and Gravel Filter

A block and gravel filter is a barrier formed around the inlet with standard concrete blocks and gravel. See [Figure II-4.17: Block and Gravel Filter](#). Design and installation specifications for block and gravel filters include:

- Provide a height of 1 to 2 feet above the inlet.
- Recess the first row of blocks 2-inches into the ground for stability.
- Support subsequent courses by placing a pressure treated wood (2x4) through the block opening.
- Do not use mortar.
- Lay some blocks in the bottom row on their side to allow for dewatering the pool.
- Place hardware cloth or comparable wire mesh with 0.5-inch openings over all block openings.
- Place gravel to just below the top of blocks on slopes of 2H:1V or flatter.
- An alternative design is a gravel berm surrounding the inlet, as follows:
 - Provide a slope of 3H:1V on the upstream side of the berm.
 - Provide a slope of 2H:1V on the downstream side of the berm.
 - Provide a 1-foot wide level rock area between the gravel berm and the inlet.
 - Use rocks 3 inches in diameter or larger on the upstream slope of the berm.
 - Use gravel 0.5 to 0.75 inch at a minimum thickness of 1-foot on the downstream slope of the berm.

Figure II-4.17: Block and Gravel Filter

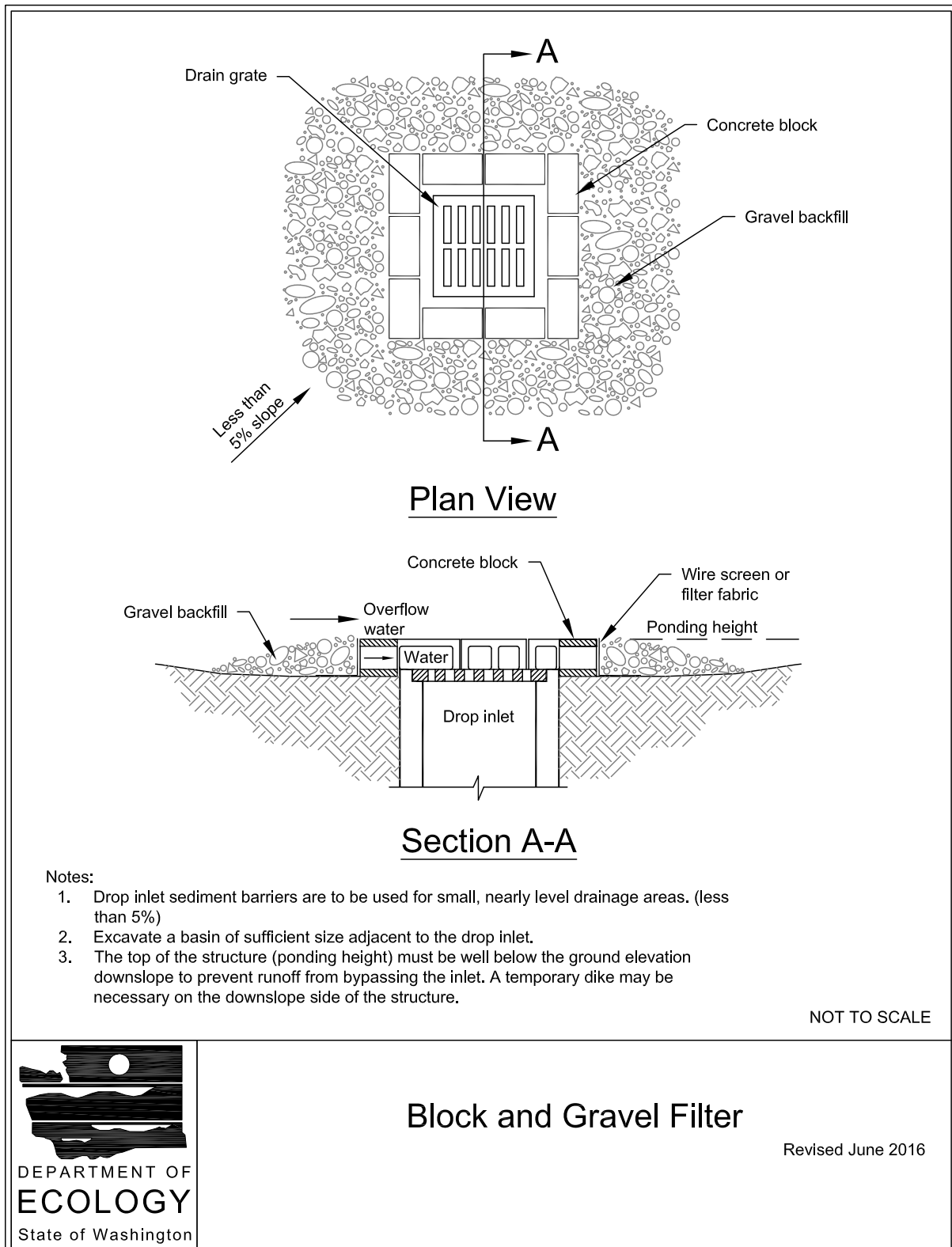

Gravel and Wire Mesh Filter

Gravel and wire mesh filters are gravel barriers placed over the top of the inlet. This method does not provide an overflow. Design and installation specifications for gravel and wire mesh filters include:

- Use a hardware cloth or comparable wire mesh with 0.5 inch openings.
 - Place wire mesh over the drop inlet so that the wire extends a minimum of 1-foot beyond each side of the inlet structure.
 - Overlap the strips if more than one strip of mesh is necessary.
- Place coarse aggregate over the wire mesh.
 - Provide at least a 12-inch depth of aggregate over the entire inlet opening and extend at least 18-inches on all sides.

Catch Basin Filters

Catch basin filters are designed by manufacturers for construction sites. The limited sediment storage capacity increases the amount of inspection and maintenance required, which may be daily for heavy sediment loads. To reduce maintenance requirements, combine a catch basin filter with another type of inlet protection. This type of inlet protection provides flow bypass without overflow and therefore may be a better method for inlets located along active rights-of-way. Design and installation specifications for catch basin filters include:

- Provides 5 cubic feet of storage.
- Requires dewatering provisions.
- Provides a high-flow bypass that will not clog under normal use at a construction site.
- Insert the catch basin filter in the catch basin just below the grating.

Curb Inlet Protection with Wooden Weir

Curb inlet protection with wooden weir is an option that consists of a barrier formed around a curb inlet with a wooden frame and gravel. Design and installation specifications for curb inlet protection with wooden weirs include:

- Use wire mesh with 0.5 inch openings.
- Use extra strength filter cloth.
- Construct a frame.
- Attach the wire and filter fabric to the frame.
- Pile coarse washed aggregate against the wire and fabric.
- Place weight on the frame anchors.

Block and Gravel Curb Inlet Protection

Block and gravel curb inlet protection is a barrier formed around a curb inlet with concrete blocks and gravel. See [Figure II-4.18: Block and Gravel Curb Inlet Protection](#). Design and installation specifications for block and gravel curb inlet protection include:

- Use wire mesh with 0.5 inch openings.
- Place two concrete blocks on their sides abutting the curb at either side of the inlet opening. These are spacer blocks.
- Place a 2x4 stud through the outer holes of each spacer block to align the front blocks.
- Place blocks on their sides across the front of the inlet and abutting the spacer blocks.
- Place wire mesh over the outside vertical face.
- Pile coarse aggregate against the wire to the top of the barrier.

Figure II-4.18: Block and Gravel Curb Inlet Protection

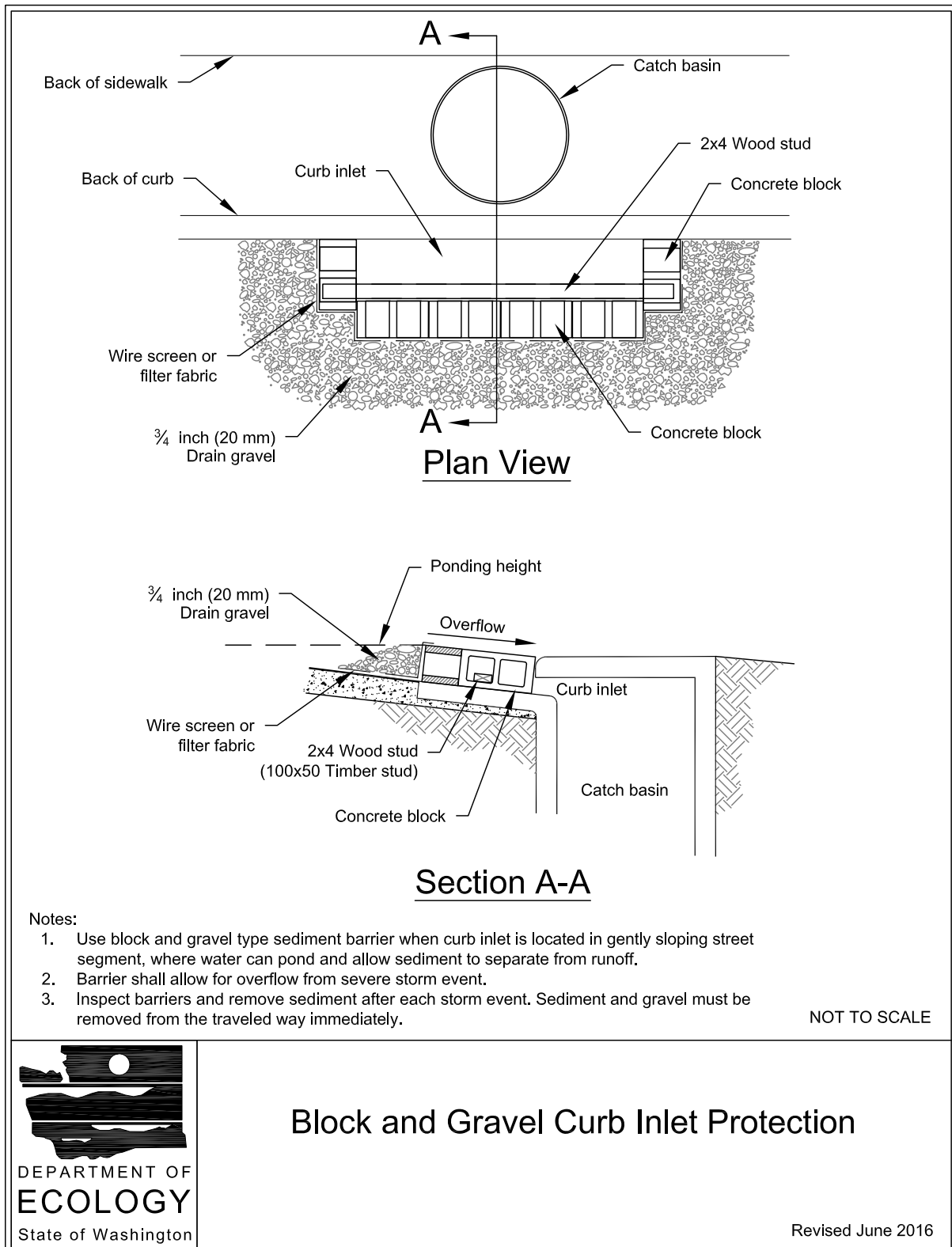

Curb and Gutter Sediment Barrier

A curb and gutter sediment barrier is a sandbag or rock berm (riprap and aggregate) 3 feet high and 3 feet wide in a horseshoe shape. See [Figure II-4.19: Curb and Gutter Barrier](#). Design and installation specifications for curb and gutter sediment barriers include:

- Construct a horseshoe shaped berm, faced with coarse aggregate if using riprap, 3 feet high and 3 feet wide, at least 2 feet from the inlet.
- Construct a horseshoe shaped sedimentation trap on the upstream side of the berm. Size the trap to sediment trap standards for protecting a culvert inlet.

Figure II-4.19: Curb and Gutter Barrier

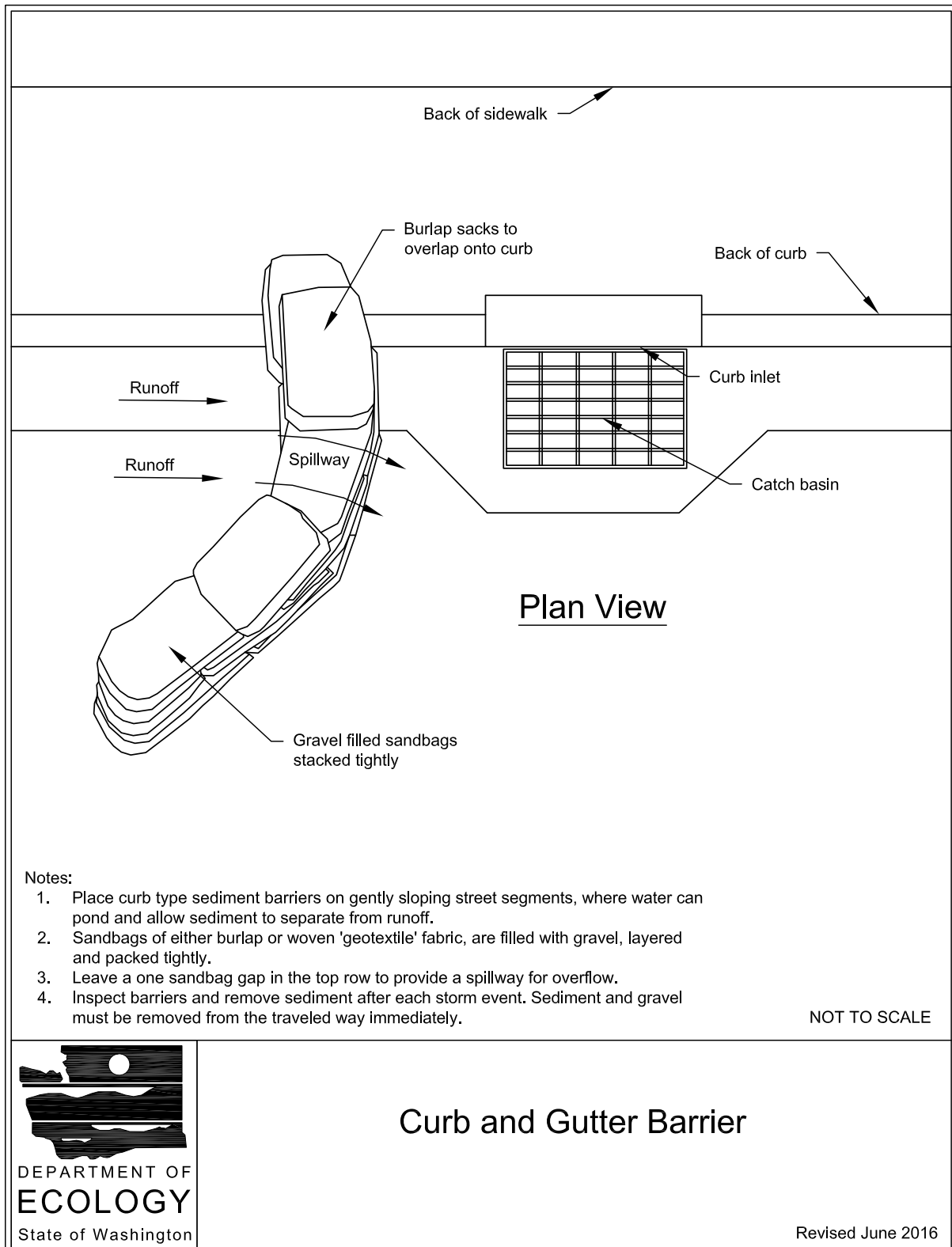

BMP C233: Silt Fence

Purpose

Silt fence reduces the transport of coarse sediment from a construction site by providing a temporary physical barrier to sediment and reducing the runoff velocities of overland flow.

Conditions of Use

Silt fence may be used downslope of all disturbed areas.

- Silt fence shall prevent sediment carried by runoff from going beneath, through, or over the top of the silt fence, but shall allow the water to pass through the fence.
- Silt fence is not intended to treat concentrated flows, nor is it intended to treat substantial amounts of overland flow. Convey any concentrated flows through the drainage system to a sediment trapping BMP.
- Do not construct silt fences in streams or use in V-shaped ditches. Silt fences do not provide an adequate method of silt control for anything deeper than sheet or overland flow.

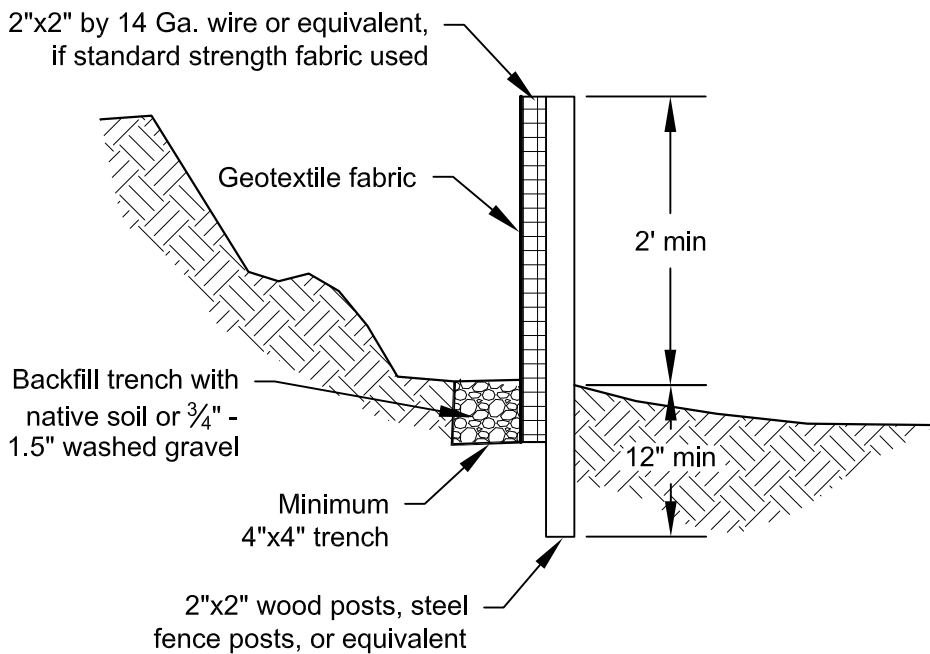
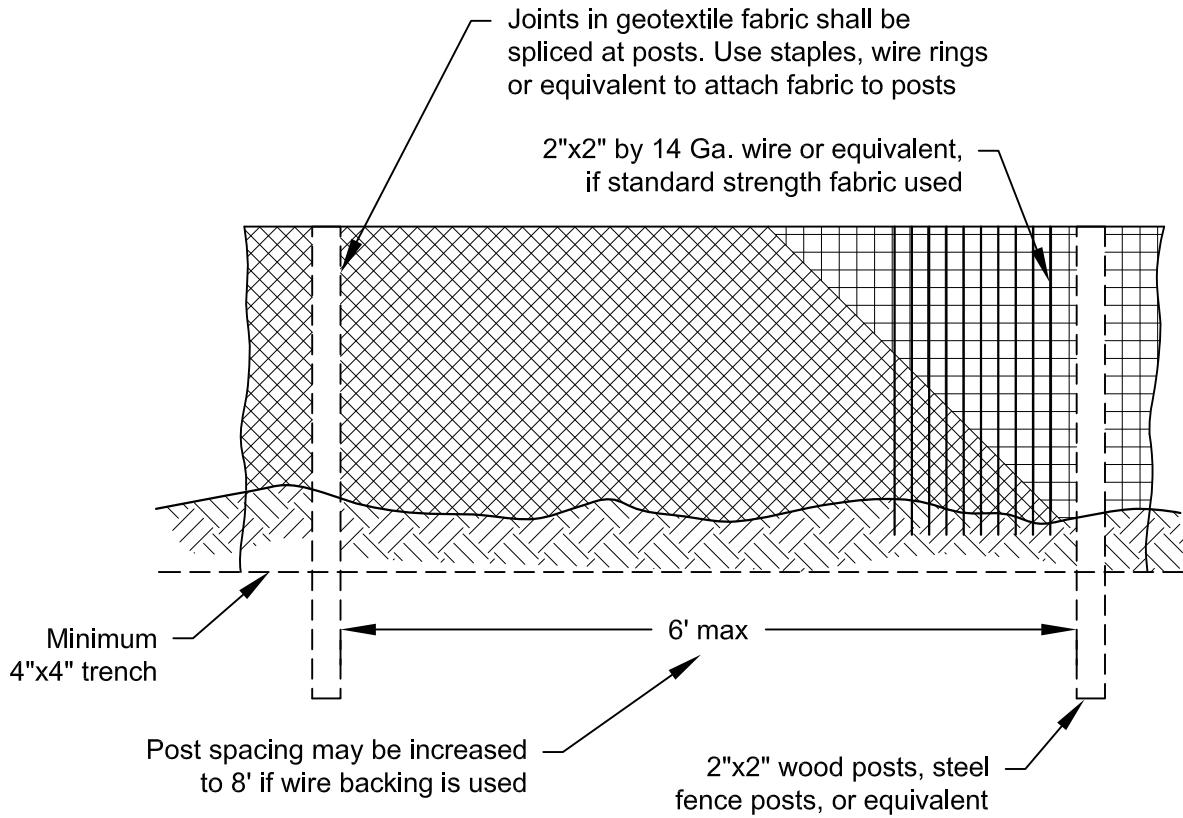

NOT TO SCALE



DEPARTMENT OF
ECOLOGY
 State of Washington

Silt Fence

Revised July 2017

Figure II-4.22: Silt Fence



[Download PDF](#)

Design and Installation Specifications

- Use in combination with other construction stormwater BMPs.
- Maximum slope steepness (perpendicular to the silt fence line) 1H:1V.
- Maximum sheet or overland flow path length to the silt fence of 100 feet.
- Do not allow flows greater than 0.5 cfs.
- Use geotextile fabric that meets the following standards. All geotextile properties listed below are minimum average roll values (i.e. the test result for any sampled roll in a lot shall meet or exceed the values shown in [Table II-4.12: Geotextile Fabric Standards for Silt Fence](#)):

Table II-4.12: Geotextile Fabric Standards for Silt Fence

Geotextile Property	Minimum Average Roll Value
Polymeric Mesh AOS (ASTM D4751)	0.60 mm maximum for slit film woven (#30 sieve). 0.30 mm maximum for all other geotextile types (#50 sieve). 0.15 mm minimum for all fabric types (#100 sieve).
Water Permittivity (ASTM D4491)	0.02 sec ⁻¹ minimum
Grab Tensile Strength (ASTM D4632)	180 lbs minimum for extra strength fabric. 100 lbs minimum for standard strength fabric.
Grab Tensile Strength (ASTM D4632)	30% maximum
Ultraviolet Resistance (ASTM D4355)	70% minimum

- Support standard strength geotextiles with wire mesh, chicken wire, 2-inch x 2-inch wire, safety fence, or jute mesh to increase the strength of the geotextile. Silt fence materials are available that have synthetic mesh backing attached.

- Silt fence material shall contain ultraviolet ray inhibitors and stabilizers to provide a minimum of 6 months of expected usable construction life at a temperature range of 0°F to 120°F.
- 100% biodegradable silt fence is available that is strong, long lasting, and can be left in place after the project is completed, if permitted by the local jurisdiction.
- Refer to [Figure II-4.22: Silt Fence](#) for standard silt fence details. Include the following Standard Notes for silt fence on construction plans and specifications:
 1. The Contractor shall install and maintain temporary silt fences at the locations shown in the Plans.
 2. Construct silt fences in areas of clearing, grading, or drainage prior to starting those activities.
 3. The silt fence shall have a 2-foot min. and a 2.5-foot max. height above the original ground surface.
 4. The geotextile fabric shall be sewn together at the point of manufacture to form fabric lengths as required. Locate all sewn seams at support posts. Alternatively, two sections of silt fence can be overlapped, provided that the overlap is long enough and that the adjacent silt fence sections are close enough together to prevent silt laden water from escaping through the fence at the overlap.
 5. Attach the geotextile fabric on the up-slope side of the posts and secure with staples, wire, or in accordance with the manufacturer's recommendations. Attach the geotextile fabric to the posts in a manner that reduces the potential for tearing.
 6. Support the geotextile fabric with wire or plastic mesh, dependent on the properties of the geotextile selected for use. If wire or plastic mesh is used, fasten the mesh securely to the up-slope side of the posts with the geotextile fabric up-slope of the mesh.
 7. Mesh support, if used, shall consist of steel wire with a maximum mesh spacing of 2-inches, or a prefabricated polymeric mesh. The strength of the wire or polymeric mesh shall be equivalent to or greater than 180 lbs grab tensile strength. The polymeric mesh must be as resistant to the same level of ultraviolet radiation as the geotextile fabric it supports.
 8. Bury the bottom of the geotextile fabric 4-inches min. below the ground surface. Backfill and tamp soil in place over the buried portion of the geotextile fabric, so that no flow can pass beneath the silt fence and scouring cannot occur. When wire or polymeric back-up support mesh is used, the wire or polymeric mesh shall extend into the ground 3-inches min.
 9. Drive or place the silt fence posts into the ground 18-inches min. A 12-inch min. depth is allowed if topsoil or other soft subgrade soil is not present and 18-inches cannot be reached. Increase fence post min. depths by 6 inches if the fence is located on slopes of 3H:1V or steeper and the slope is perpendicular to the fence. If required post depths cannot be obtained, the posts shall be adequately secured by bracing or guying to prevent overturning of the fence due to sediment loading.

10. Use wood, steel or equivalent posts. The spacing of the support posts shall be a maximum of 6 feet. Posts shall consist of one of the following:
 - Wood with minimum dimensions of 2 inches by 2 inches by 3 feet. Wood shall be free of defects such as knots, splits, or gouges.
 - No. 6 steel rebar or larger.
 - ASTM A 120 steel pipe with a minimum diameter of 1-inch.
 - U, T, L, or C shape steel posts with a minimum weight of 1.35 lbs./ft.
 - Other steel posts having equivalent strength and bending resistance to the post sizes listed above.
 11. Locate silt fences on contour as much as possible, except at the ends of the fence, where the fence shall be turned uphill such that the silt fence captures the runoff water and prevents water from flowing around the end of the fence.
 12. If the fence must cross contours, with the exception of the ends of the fence, place check dams perpendicular to the back of the fence to minimize concentrated flow and erosion. The slope of the fence line where contours must be crossed shall not be steeper than 3H:1V.
 - Check dams shall be approximately 1 foot deep at the back of the fence. Check dams shall be continued perpendicular to the fence at the same elevation until the top of the check dam intercepts the ground surface behind the fence.
 - Check dams shall consist of crushed surfacing base course, gravel backfill for walls, or shoulder ballast. Check dams shall be located every 10 feet along the fence where the fence must cross contours.
- Refer to [Figure II-4.23: Silt Fence Installation by Slicing Method](#) for slicing method details. The following are specifications for silt fence installation using the slicing method:
 1. The base of both end posts must be at least 2 to 4 inches above the top of the geotextile fabric on the middle posts for ditch checks to drain properly. Use a hand level or string level, if necessary, to mark base points before installation.
 2. Install posts 3 to 4 feet apart in critical retention areas and 6 to 7 feet apart in standard applications.
 3. Install posts 24 inches deep on the downstream side of the silt fence, and as close as possible to the geotextile fabric, enabling posts to support the geotextile fabric from upstream water pressure.
 4. Install posts with the nipples facing away from the geotextile fabric.
 5. Attach the geotextile fabric to each post with three ties, all spaced within the top 8 inches of the fabric. Attach each tie diagonally 45 degrees through the fabric, with each puncture at least 1-

inch vertically apart. Each tie should be positioned to hang on a post nipple when tightening to prevent sagging.

6. Wrap approximately 6 inches of the geotextile fabric around the end posts and secure with 3 ties.
7. No more than 24 inches of a 36 inch geotextile fabric is allowed above ground level.
8. Compact the soil immediately next to the geotextile fabric with the front wheel of the tractor, skid steer, or roller exerting at least 60 pounds per square inch. Compact the upstream side first and then each side twice for a total of four trips. Check and correct the silt fence installation for any deviation before compaction. Use a flat-bladed shovel to tuck the fabric deeper into the ground if necessary.

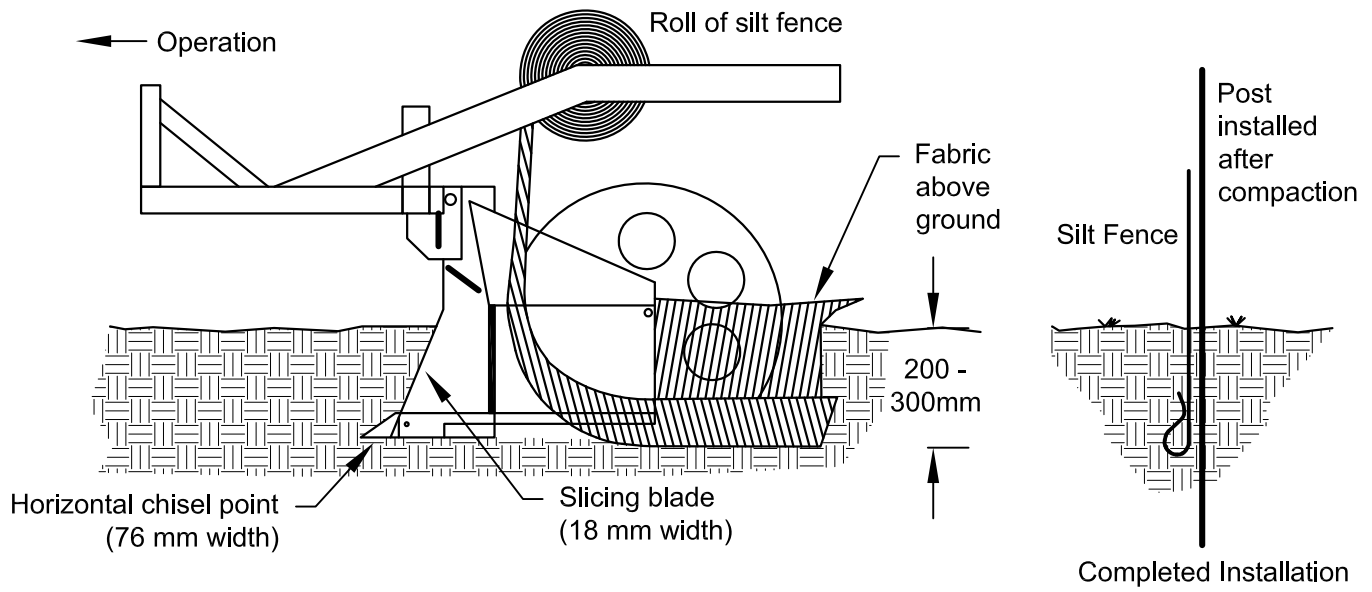
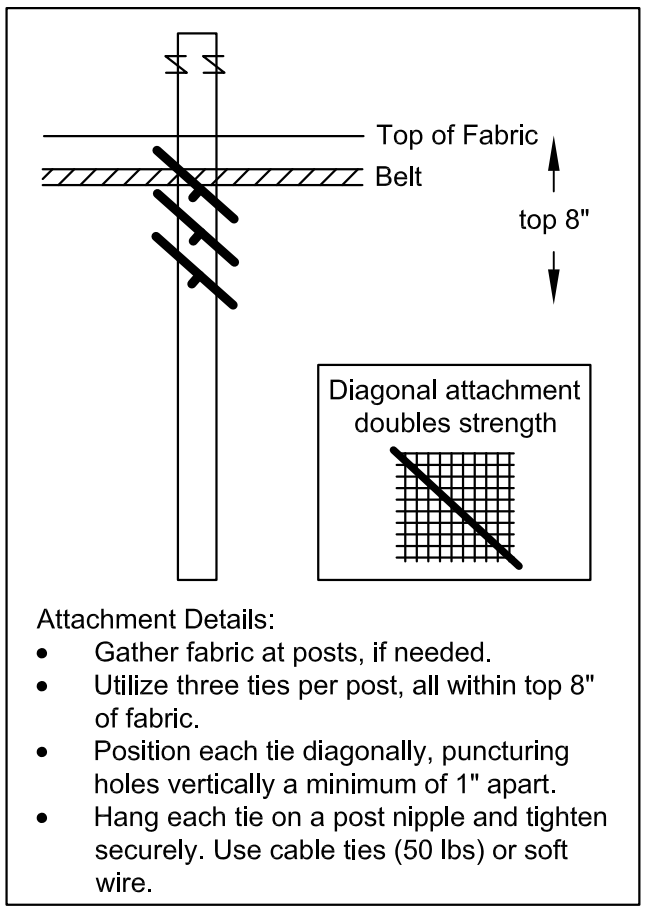
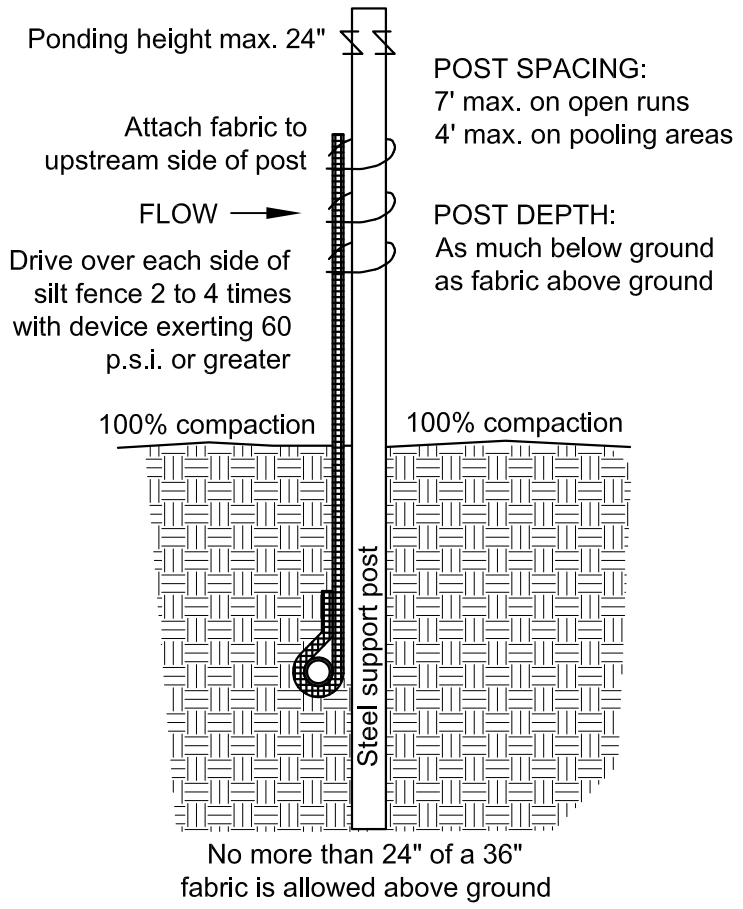

Vibratory plow is not acceptable because of horizontal compaction

NOT TO SCALE



Silt Fence Installation by Slicing Method

Figure II-4.23: Silt Fence Installation by Slicing Method

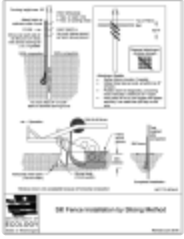

[Download PDF](#)

Maintenance Standards

- Repair any damage immediately.
- Intercept and convey all evident concentrated flows uphill of the silt fence to a sediment trapping BMP.
- Check the uphill side of the silt fence for signs of the fence clogging and acting as a barrier to flow and then causing channelization of flows parallel to the fence. If this occurs, replace the fence and remove the trapped sediment.
- Remove sediment deposits when the deposit reaches approximately one-third the height of the silt fence, or install a second silt fence.
- Replace geotextile fabric that has deteriorated due to ultraviolet breakdown.

Washington State Department of Ecology

2024 Stormwater Management Manual for Western Washington (2024 SWMMWW)

Publication No. 24-10-013

BMP C240: Sediment Trap

Purpose

A sediment trap is a small temporary ponding area with a gravel outlet used to collect and store sediment from sites during construction. Sediment traps, along with other perimeter controls, shall be installed before any land disturbance takes place in the contributing drainage area.

Conditions of Use

- Sediment traps are intended for use on sites where the contributing drainage area is less than 3 acres, with no unusual drainage features, and a projected build-out time of 6 months or less. The sediment trap is a temporary measure (with a design life of approximately 6 months) and shall be maintained until the contributing drainage area is permanently protected against erosion by vegetation and/or structures.
- Sediment traps are only effective in removing sediment down to about the medium silt size fraction. Runoff with sediment of finer grades (fine silt and clay) will pass through untreated, emphasizing the need to control erosion to the maximum extent first.
- Projects that are constructing permanent Flow Control BMPs, or permanent Runoff Treatment BMPs that use ponding for treatment, may use the rough-graded or final-graded permanent BMP footprint for the temporary sediment trap. When permanent BMP footprints are used as temporary sediment traps, the surface area requirement of the sediment trap must be met. If the surface area requirement of the sediment trap is larger than the surface area of the permanent BMP, then the sediment trap shall be enlarged beyond the permanent BMP footprint to comply with the surface area requirement.
- A floating pond skimmer may be used for the sediment trap outlet if approved by the Local Permitting Authority.
- Sediment traps may not be feasible on utility projects due to the limited work space or the short-term nature of the work. Portable tanks may be used in place of sediment traps for utility projects.

Design and Installation Specifications

- See [Figure II-4.26: Cross Section of Sediment Trap](#) and [Figure II-4.27: Sediment Trap Outlet](#) for details.
- To determine the sediment trap geometry, first calculate the design surface area (SA) of the trap, measured at the invert of the weir. Use the following equation:

$$SA = FS * (Q_2/V_s)$$

where:

SA = Design surface area of the trap (square feet)

FS = A safety factor of 2 to account for non-ideal settling.

Q₂ = The peak volumetric flow rate (cubic feet per second), calculated using one of the following options:

o Option 1 - Single Event Hydrograph Method

The peak volumetric flow rate calculated using a 10-minute time step from a Type 1A, 2-year, 24-hour frequency storm for the developed condition. The 10-year peak volumetric flow rate shall be used if the project size, expected timing and duration of construction, or downstream conditions warrant a higher level of protection.

o Option 2 - The Rational Method

For construction sites that are less than 1 acre, the peak volumetric flow rate calculated using the Rational Method.

V_s = The settling velocity of the soil particle of interest. The 0.02 mm (medium silt) particle with an assumed density of 2.65 g/cm³ has been selected as the particle of interest and has a settling velocity (V_s) of 0.00096 ft/sec.

Therefore, the equation for computing sediment trap surface area becomes:

$$SA = 2 \times Q_2 / 0.00096$$

or

2080 square feet per cfs of inflow

- Sediment trap depth shall be 3.5 feet minimum from the bottom of the trap to the top of the overflow weir.
- To aid in determining sediment depth, all sediment traps shall have a staff gauge with a prominent mark 1 foot above the bottom of the trap.
- Design the discharge from the sediment trap by using the guidance for discharge from temporary sediment ponds in [BMP C241: Sediment Pond \(Temporary\)](#).

Maintenance Standards

- Sediment shall be removed from the trap when it reaches 1 foot in depth.
- Any damage to the trap embankments or slopes shall be repaired.

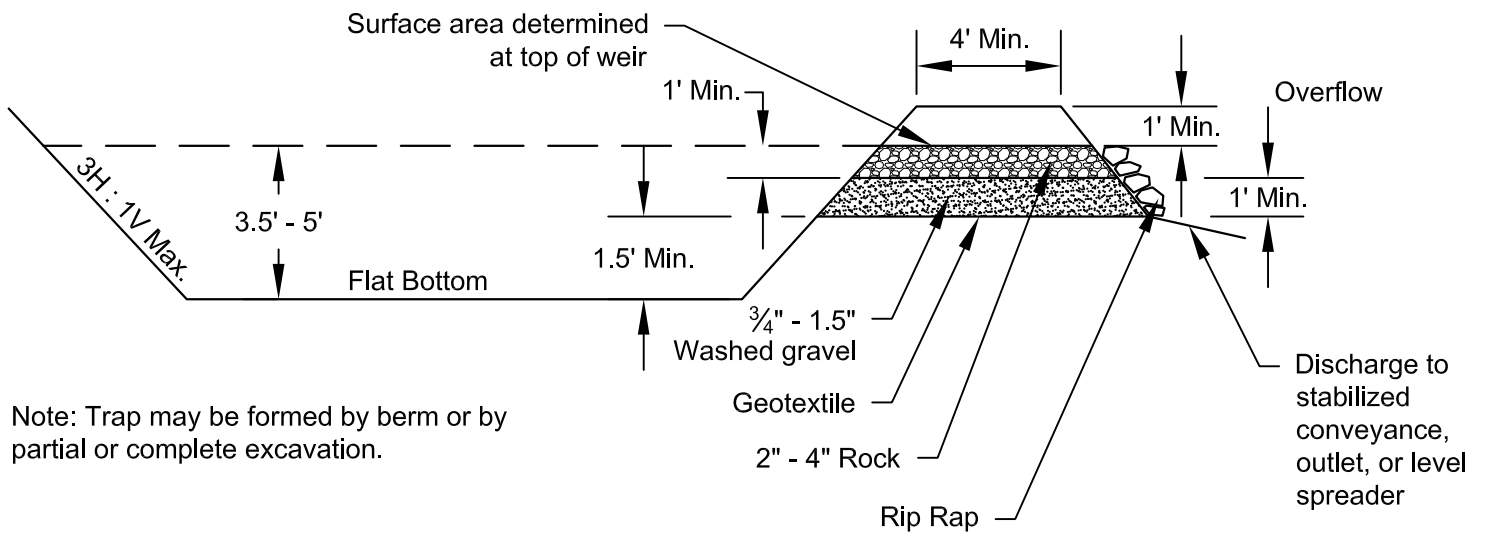

Note: Trap may be formed by berm or by partial or complete excavation.

NOT TO SCALE



DEPARTMENT OF
ECOLOGY
State of Washington

Cross Section of Sediment Trap

Revised June 2016

Figure II-4.26: Cross Section of Sediment Trap



[Download PDF](#)

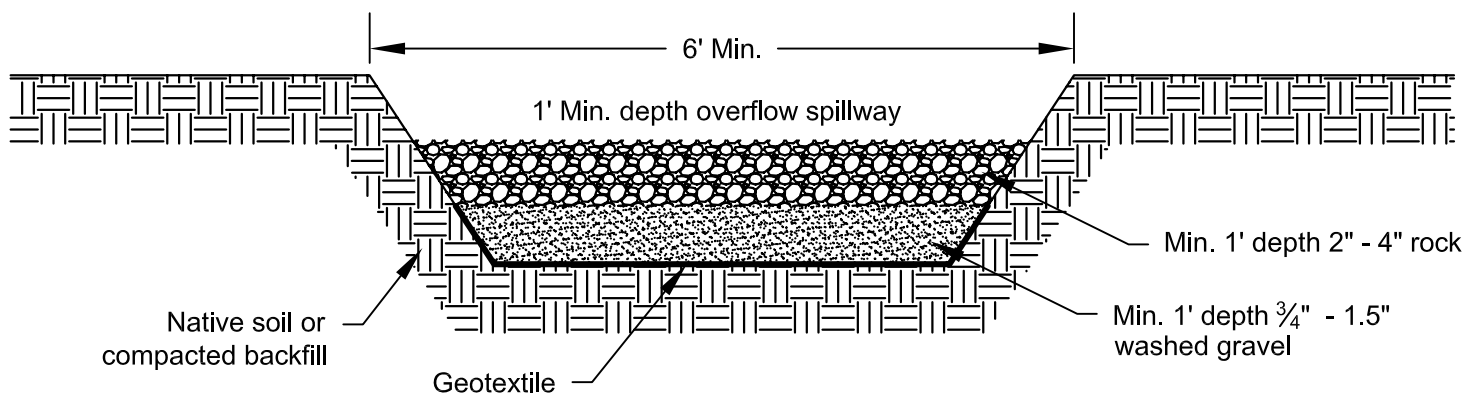

NOT TO SCALE

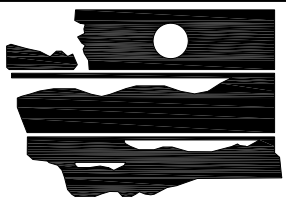

DEPARTMENT OF
ECOLOGY
State of Washington

Sediment Trap Outlet

Revised June 2016

Figure II-4.27: Sediment Trap Outlet

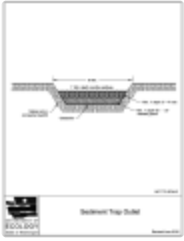

[Download PDF](#)

Washington State Department of Ecology

2024 Stormwater Management Manual for Western Washington (2024 SWMMWW)

Publication No. 24-10-013

C. Correspondence

Not Applicable

D. Site Inspection Form

Construction Stormwater Site Inspection Form

Project Name _____ **Permit #** _____ **Inspection Date** _____ **Time** _____

Name of Certified Erosion Sediment Control Lead (CESCL) or qualified inspector if *less than one acre*

Print Name: _____

Approximate rainfall amount since the last inspection (in inches): _____

Approximate rainfall amount in the last 24 hours (in inches): _____

Current Weather Clear Cloudy Mist Rain Wind Fog

A. Type of inspection: Weekly Post Storm Event Other

B. Phase of Active Construction (check all that apply):

Pre Construction/installation of erosion/sediment controls	<input type="checkbox"/>	Clearing/Demo/Grading	<input type="checkbox"/>	Infrastructure/storm/roads	<input type="checkbox"/>
Concrete pours	<input type="checkbox"/>	Vertical Construction/buildings	<input type="checkbox"/>	Utilities	<input type="checkbox"/>
Offsite improvements	<input type="checkbox"/>	Site temporary stabilized	<input type="checkbox"/>	Final stabilization	<input type="checkbox"/>

C. Questions:

- | | | | | |
|--|-----|----|-------|-------|
| 1. Were all areas of construction and discharge points inspected? | Yes | No | _____ | _____ |
| 2. Did you observe the presence of suspended sediment, turbidity, discoloration, or oil sheen | Yes | No | _____ | _____ |
| 3. Was a water quality sample taken during inspection? (<i>refer to permit conditions S4 & S5</i>) | Yes | No | _____ | _____ |
| 4. Was there a turbid discharge 250 NTU or greater, or Transparency 6 cm or less?* | Yes | No | _____ | _____ |
| 5. If yes to #4 was it reported to Ecology? | Yes | No | _____ | _____ |
| 6. Is pH sampling required? pH range required is 6.5 to 8.5. | Yes | No | _____ | _____ |

If answering yes to a discharge, describe the event. Include when, where, and why it happened; what action was taken, and when.

*If answering yes to # 4 record NTU/Transparency with continual sampling daily until turbidity is 25 NTU or less/ transparency is 33 cm or greater.

Sampling Results: _____ Date: _____

Parameter	Method (circle one)	Result			Other/Note
		NTU	cm	pH	
Turbidity	tube, meter, laboratory				
pH	Paper, kit, meter				

Construction Stormwater Site Inspection Form

D. Check the observed status of all items. Provide "Action Required" details and dates.

Element #	Inspection	BMPs Inspected			BMP needs maintenance	BMP failed	Action required (describe in section F)
		yes	no	n/a			
1 Clearing Limits	Before beginning land disturbing activities are all clearing limits, natural resource areas (streams, wetlands, buffers, trees) protected with barriers or similar BMPs? (high visibility recommended)						
2 Construction Access	Construction access is stabilized with quarry spalls or equivalent BMP to prevent sediment from being tracked onto roads?						
	Sediment tracked onto the road way was cleaned thoroughly at the end of the day or more frequent as necessary.						
3 Control Flow Rates	Are flow control measures installed to control stormwater volumes and velocity during construction and do they protect downstream properties and waterways from erosion?						
	If permanent infiltration ponds are used for flow control during construction, are they protected from siltation?						
4 Sediment Controls	All perimeter sediment controls (e.g. silt fence, wattles, compost socks, berms, etc.) installed, and maintained in accordance with the Stormwater Pollution Prevention Plan (SWPPP).						
	Sediment control BMPs (sediment ponds, traps, filters etc.) have been constructed and functional as the first step of grading.						
	Stormwater runoff from disturbed areas is directed to sediment removal BMP.						
5 Stabilize Soils	Have exposed un-worked soils been stabilized with effective BMP to prevent erosion and sediment deposition?						

Construction Stormwater Site Inspection Form

Element #	Inspection	BMPs Inspected			BMP needs maintenance	BMP failed	Action required (describe in section F)
		yes	no	n/a			
5 Stabilize Soils Cont.	Are stockpiles stabilized from erosion, protected with sediment trapping measures and located away from drain inlet, waterways, and drainage channels?						
	Have soils been stabilized at the end of the shift, before a holiday or weekend if needed based on the weather forecast?						
6 Protect Slopes	Has stormwater and ground water been diverted away from slopes and disturbed areas with interceptor dikes, pipes and or swales?						
	Is off-site storm water managed separately from stormwater generated on the site?						
	Is excavated material placed on uphill side of trenches consistent with safety and space considerations?						
	Have check dams been placed at regular intervals within constructed channels that are cut down a slope?						
7 Drain Inlets	Storm drain inlets made operable during construction are protected.						
	Are existing storm drains within the influence of the project protected?						
8 Stabilize Channel and Outlets	Have all on-site conveyance channels been designed, constructed and stabilized to prevent erosion from expected peak flows?						
	Is stabilization, including armoring material, adequate to prevent erosion of outlets, adjacent stream banks, slopes and downstream conveyance systems?						
9 Control Pollutants	Are waste materials and demolition debris handled and disposed of to prevent contamination of stormwater?						
	Has cover been provided for all chemicals, liquid products, petroleum products, and other material?						
	Has secondary containment been provided capable of containing 110% of the volume?						
	Were contaminated surfaces cleaned immediately after a spill incident?						
	Were BMPs used to prevent contamination of stormwater by a pH modifying sources?						

Construction Stormwater Site Inspection Form

Element #	Inspection	BMPs Inspected			BMP needs maintenance	BMP failed	Action required (describe in section F)
		yes	no	n/a			
9 Cont.	Wheel wash wastewater is handled and disposed of properly.						
10 Control Dewatering	Concrete washout in designated areas. No washout or excess concrete on the ground.						
	Dewatering has been done to an approved source and in compliance with the SWPPP.						
	Were there any clean non turbid dewatering discharges?						
11 Maintain BMP	Are all temporary and permanent erosion and sediment control BMPs maintained to perform as intended?						
12 Manage the Project	Has the project been phased to the maximum degree practicable?						
	Has regular inspection, monitoring and maintenance been performed as required by the permit?						
	Has the SWPPP been updated, implemented and records maintained?						
13 Protect LID	Is all Bioretention and Rain Garden Facilities protected from sedimentation with appropriate BMPs?						
	Is the Bioretention and Rain Garden protected against over compaction of construction equipment and foot traffic to retain its infiltration capabilities?						
	Permeable pavements are clean and free of sediment and sediment laden-water runoff. Muddy construction equipment has not been on the base material or pavement.						
	Have soiled permeable pavements been cleaned of sediments and pass infiltration test as required by stormwater manual methodology?						
	Heavy equipment has been kept off existing soils under LID facilities to retain infiltration rate.						

E. Check all areas that have been inspected. ✓

All in place BMPs All disturbed soils All concrete wash out area All material storage areas
 All discharge locations All equipment storage areas All construction entrances/exits

Construction Stormwater Site Inspection Form

F. Elements checked "Action Required" (section D) describe corrective action to be taken. List the element number; be specific on location and work needed. Document, initial, and date when the corrective action has been completed and inspected.

Element #	Description and Location	Action Required	Completion Date	Initials

Attach additional page if needed

Sign the following certification:

"I certify that this report is true, accurate, and complete, to the best of my knowledge and belief"

Inspected by: (print) _____ (Signature) _____ Date: _____

Title/Qualification of Inspector: _____

E. Construction Stormwater General Permit (CSWGP)

Refer to the 2026 Construction Stormwater General Permit from the Washington Department of Ecology, effective January 1 2026.

F. 303(d) List Waterbodies / TMDL Waterbodies Information

Not applicable – No known contaminants.

G. Contaminated Site Information

Not applicable – No known contaminants.

Refer to the Phase I Environmental Site Assessment prepared by Terracon Consultants, Inc. on March 19, 2025.

H. Engineering Calculations

Sediment Trap Calculations

Sediment Trap Calculations

Area 0.92 acres
Rational Coefficient 0.64573425
Rainfall Intensity 2.417 in/hr **10 yr**

	Peak Runoff
10 yr	1.44

$$SA = 2 \times Q_2 / 0.00096$$

SA (sf)	2992
---------	------

Intensity		
m*	5.70	
n*	0.533	
Tc	5.00	minutes
I	2.417	in/hr

*Tacoma values used for m & n
for table 2-4