

STORMWATER REPORT

For

**APL Properties
212 Todd Road NE
Puyallup, WA 98371**

**January 13th, 2023
Revised April 15th, 2024**



04/15/2024

**Prepared by:
Priscila Lee**

Encompass Engineering Job No. 21715

Prepared For:

**American Pride Lending, LLC
PO Box 1226
Kent, WA 98035**

Table of Contents

List of Figures 1

I. PROJECT OVERVIEW 1

II. CONDITIONS SUMMARY AND SITE ANALYSIS 2

III. OFF-SITE ANALYSIS 7

IV. PERMANENT STORMWATER CONTROL PLAN 10

V. CONVEYANCE SYSTEM ANALYSIS AND DESIGN.....12

VI. CONSTRUCTION STORMWATER POLLUTION PREVENTION PLAN (SWPPP)..... 13

VII. SPECIAL REPORTS AND STUDIES..... 15

VIII. OTHER PERMITS..... 15

IX. OPERATION AND MAINTENANCE MANUAL 15

X. DECLARATION OF COVENANT OR EASEMENT FOR PRIVATELY MAINTAINED FLOW CONTROL AND TREATMENT FACILITIES 15

XI. DECLARATION OF COVENANT OR EASEMENT FOR ON-SITE STORMWATER MANAGEMENT FACILITIES..... 15

XII. BOND QUANTITIES WORKSHEET 15

List of Figures

- Figure 1 – Vicinity Map
- Figure 2 – Soils Map and Legend
- Figure 3 – Drainage Review Flow Chart

Appendix A

Infiltration Evaluation by Earth Solutions NW, LLC (dated June 28, 2022)

Appendix B

Wetland and Stream Reconnaissance by Altmann Oliver Associates, LLC (dated July 15, 2022)

Appendix C

Operation and Maintenance Manual

Appendix D

WWHM Results

I. PROJECT OVERVIEW

Project: APL Properties
Site Address: 212 Todd Road NE, Puyallup, WA 98371
King County Tax Parcel: 042022-2008
Site Area: 39,779 SF (0.91 AC) – as surveyed
Zoning District: RM-20 (High Density Multi-Family Residential)

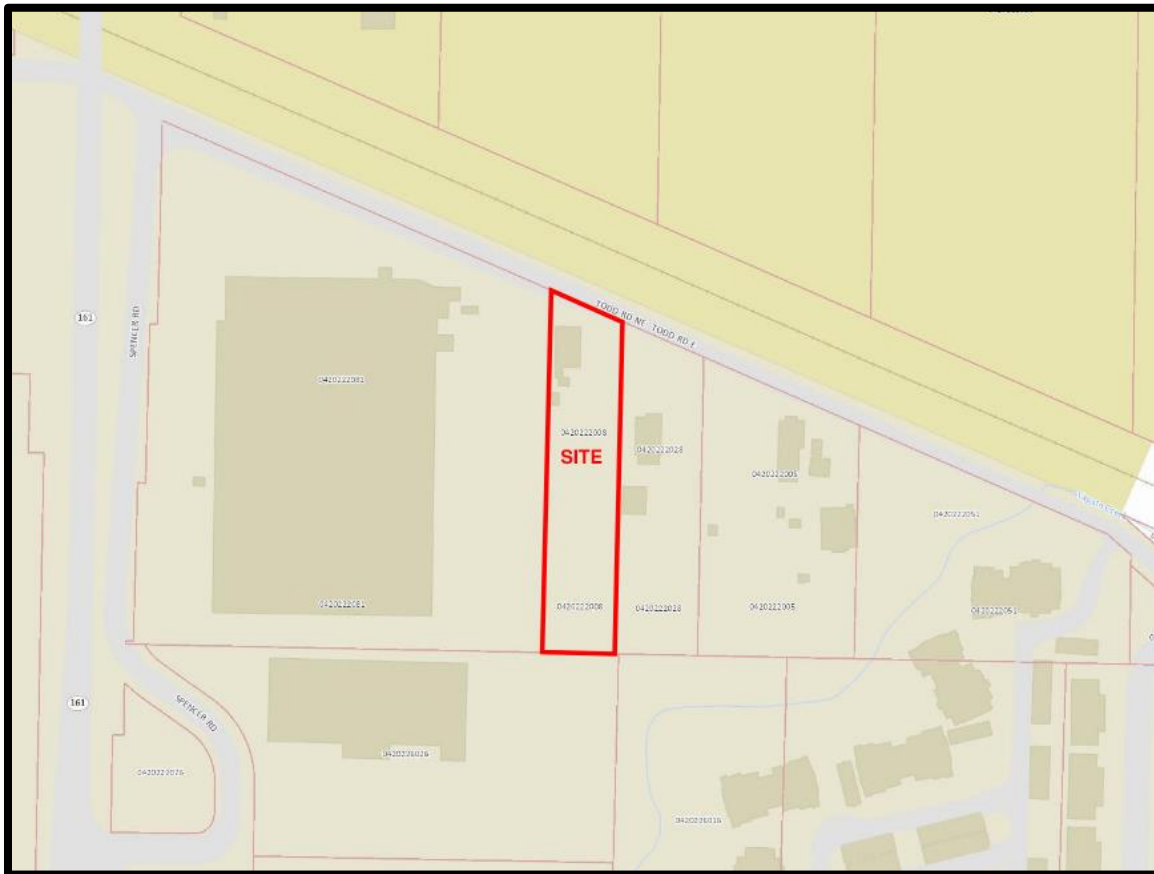

Figure 1: Vicinity Map

Pre-developed Site Conditions:

The proposed project is located within parcel number 042022-2008 on the south side of Todd Road NE in the City of Puyallup. The 39,779 SF (0.91 AC) parcel is currently developed with a 1,653 SF (foot print) single-family residence, a deck, and a gravel storage yard. The site is mostly flat with 0-2% slopes in the northern direction. The site is bordered to the north by Todd Road NE, to the east by a single-family residential lot, and to the west and south by industrial lots.

Critical areas: According to City of Puyallup – Critical Areas App the northern side of site is located within the wellhead protection area. Additionally, the site is located adjacent to the south to a stream CAT II and its buffer is located within the southeastern of the site. Please refer to Wetland and Stream Reconnaissance by Altmann Oliver Associates, LLC (Appendix B) for more information on stream and its associated buffer. No other critical areas were identified.

II. CONDITIONS SUMMARY AND SITE ANALYSIS

Existing Conditions:

The project proposes the demolition of all appurtenances. The project is located in the City of Puyallup on a 39,779 SF (0.91 AC) parcel that is zoned as RM-20 (High Density Multi-Family Residential). The site currently contains a 1,653 SF single-family residence, 137 SF of uncovered steps/ramp/decking, and 34,121 SF of uncovered storage yard gravel. According to City of Puyallup – Critical Areas App the northern side of site is located within the wellhead protection area; Additionally, there is a wetland located just southeast of the site that is associated with Wapato Creek. Please refer to Appendix B for more information on the wetland.

The soils on site have been classified by the United States Geological Survey (USGS) Web Soils Survey as Puyallup fine sandy loam (31A) – (see Figure 2 below). The site is generally flat with 0-2% slopes in the southern direction. The Infiltration Evaluation by Earth Solutions NW, LLC (Appendix A) indicates that the native soil is a combination of silty sand and sandy silt, with the groundwater table encountered beginning at 5-5.5 FT below grade. Please refer to Appendix A for a copy of the Infiltration Evaluation.



Map Unit Symbol	Map Unit Name	Acres in AOI	Percent of AOI
31A	Puyallup fine sandy loam	1.0	100.0%
Totals for Area of Interest		1.0	100.0%

Figure 2: Soils Map and Legend

Proposed Conditions:

The project proposes the construction of a total of 10,195 of roof area, a 10,145 SF of asphalt driveway located along the western side of the site, and 1,440 SF of walkways/steps. Additionally, the project proposes 328 SF off-site driveway in the public right of-way. This results in a total of 21,780 SF (54.75%); however, since there is 10,056 SF of ROW dedication the new site area is 38,723 SF (39,779 SF – 1,056 SF = 38,723 SF) 56.25% of on-site impervious area.

Site Analysis Conditions:

This project proposes to meet the requirements detailed in the 2019 Stormwater Management Manual for Western Washington (SWMMWW). Per Figure I-3.2 of the 2019 SWMMWW (shown as Figure 3 below), all minimum requirements apply to the new and replaced hard surfaces and converted vegetation areas on site. A summary of the minimum requirements is provided on the following page.

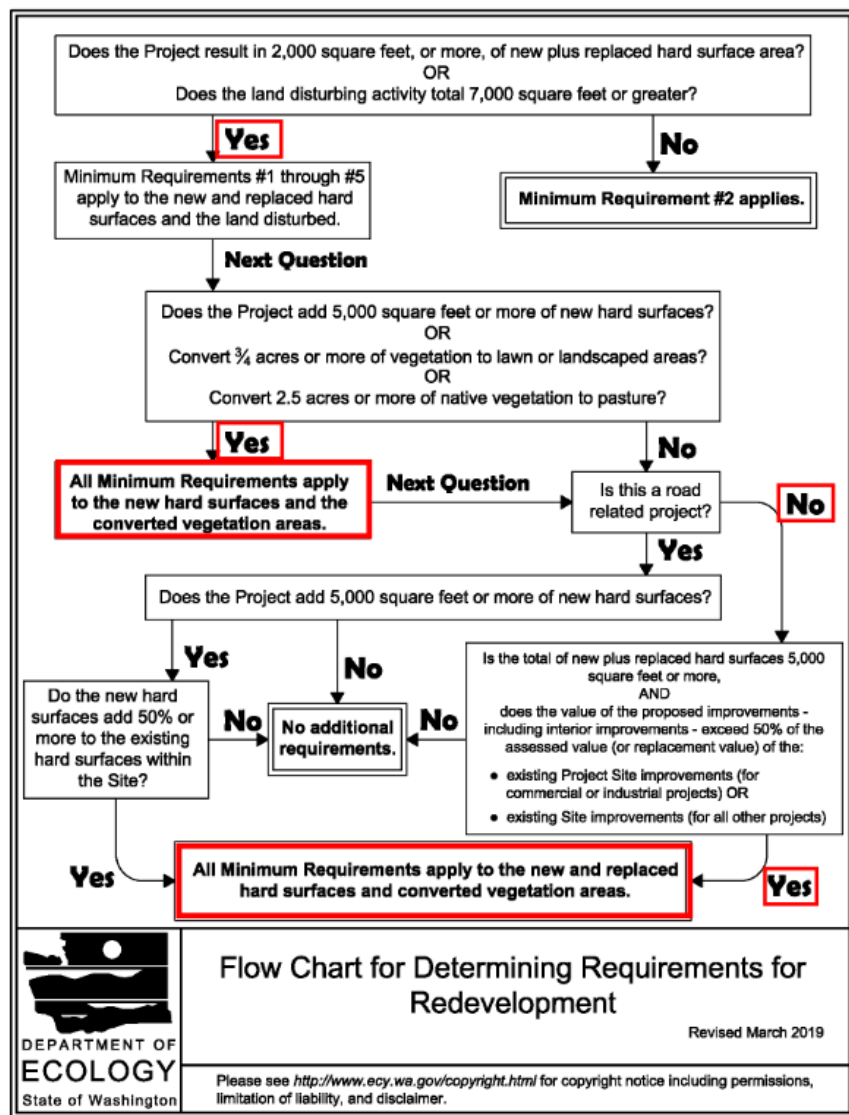

Figure 3: Drainage Review Flowchart

Minimum Requirement #1: Preparation of Stormwater Site Plans

This Stormwater Report and the Plan Set have been prepared to satisfy Minimum Requirement #1.

Minimum Requirement #2: Construction Stormwater Pollution Prevention Plan

A Temporary Erosion and Sediment Control (TESC) Plan for Construction Activities has been prepared for this project and submitted with the Civil Plans. A short form Construction Stormwater Pollution Prevention Plan has been included in Section V of this TIR.

Minimum Requirement #3: Source Control of Pollution

In order to meet the conservation flow control standard the project proposes an onsite Contech CMP detention tank. Stormwater from all new impervious areas will be collected and conveyed to a detention tank system where a Contech Filterra stormwater filter is installed prior to enter the detention system. Please refer to Appendix C for a copy of the full WWHM data output and Chapter IV for additional discussion on the flow control analysis.

Minimum Requirement #4: Preservation of Natural Drainage Systems and Outfalls

In the existing condition, stormwater runoff sheet flows through the lawn/gravel towards the south edge of the property or infiltrates on-site into the native soils. In the developed condition, stormwater from the new impervious areas will be collected and conveyed to a detention tank system where a Contech Filterra stormwater filter is installed prior to enter the detention system which will outlet the runoff into the public stormwater drainage system in Todd Road NE. See Offsite Analysis in Section III of this Stormwater Report for more details on the drainage patterns of the site.

Minimum Requirement #5: On-Site Stormwater Management

List #2 in Table I-3.2 of the 2019 SWMMWW was used to select on-site stormwater BMPs for projects triggering Minimum Requirements #1 through #9. The selection of BMPs for each surface is summarized below:

Lawn and Landscaped Areas:

All new lawn and landscaped areas will meet post-construction soil quality and depth requirements in accordance with BMP T5.13 in Chapter 5 of Volume V of the 2019 Stormwater Maintenance Manual for Western Washington (SWMMWW).

Roofs:

1. **Full Dispersion:** Full dispersion is infeasible due to the space limitations. There is not enough space available to satisfy the required over 100 FT vegetated flow path.
2. **Full Infiltration, Bioretention, Downspout Dispersion Perforated Stub-out Connections :** The site does not include enough to utilize any of the BMP'S , as the project encompasses most of the lot area; additionally, The Infiltration Evaluation by Earth Solutions NW, LLC (Appendix A) indicates that the native soil is a combination of silty sand and sandy silt, with the groundwater table encountered beginning at 5-5.5 FT below grade with an infiltration rate of 0.35 Inc-hour which indicates poor soils infiltration capacity, and limits the depth of the infiltration facilities.

Other Hard Surfaces:

1. **Full Dispersion:** Infeasible. A conforming 100 FT flow path is not available on-site.
2. **Permeable Pavement:** Infeasible. According to, The Infiltration Evaluation by Earth Solutions NW, LLC (Appendix A) indicates that the native soil is a combination of silty sand and sandy silt, with the groundwater table encountered beginning at 5-5.5 FT below grade with an infiltration rate of 0.35 Inc-hour was considered low to mitigate 10,145 SF of the proposed driveway due to the low infiltration rate indicating poor soils infiltration capacity.
3. **Bioretention:** Infeasible. The site does not include enough space for bioretention, as the project encompasses most of the lot area.
4. **Sheet Flow Dispersion/Concentrated Flow Dispersion:** Infeasible. The site does not include enough space for sheet flow dispersion or concentrated flow dispersion.

As none of the BMPs in List #2 are viable for the mitigation of the gravel storage yard, a 48" CMP perforated detention tank system with a Contech Filtterra stormwater filter will be utilized for flow control.

Minimum Requirement #6: Runoff Treatment

Proposed pollution generating impervious surfaces (PGIS) on the project site total 10,145 SF. Projects proposing more than 5,000 SF of new PGIS are required to meet the water quality requirements. Therefore, a Contech Filtterra stormwater filter is proposed prior to detention. Please refer to Section IV of this Stormwater Report for more information on the sizing and design of the proposed water quality devices.

Minimum Requirement #7: Flow Control

According to Section I-3.4.7 of the 2019 SWMMWW, projects that propose more than 10,000 SF of impervious surfaces are require flow control. This project added more than 10,000 SF (21,780 SF of impervious area), therefore flow control has been analyzed. The project proposes the addition of 48" CMP solid detention tank system to mitigate the entire 21,780 SF of impervious area. A Contech Filtterra water quality system will be installed prior to detention then released into the existing public stormwater system. The detention system was sized using WWHM. Please refer to Appendix D for a copy of the full WWHM data output. See Chapter IV of this TIR for additional discussion.

Minimum Requirement #8: Wetlands Protection

There are no wetlands on or adjacent to the project site.

Minimum Requirement #9: Operations and Maintenance

An Operation and Maintenance Manual is included as Appendix C.

Special Requirements**Special Requirement #1: Other Adopted Area-Specific Requirements**

Basin Plan – N/A
Master Drainage Plan – N/A
Salmon Conservation Plans – N/A
Flood Hazard Management Plan – N/A
Lake Management Plans – N/A

Special Requirement #2: Flood Hazard Area Delineation

The proposed project is not located within a delineated FEMA flood zone.

Special Requirement #3: Flood Protection Facilities

This project does not rely on or propose to modify or construct a new flood protection facility.

Special Requirement #4: Source controls

Source control is not warranted for this project.

Special Requirement #5: Oil Control

This project is not considered high-use or in need of oil control.

III. OFF-SITE ANALYSIS

In accordance with Section I-3.5.3 of the 2019 SMMWW, an off-site analysis was performed on February 23rd, 2024, at approximately 10:30 am. The weather was around 50 degrees and cloudy in moderately wet conditions.

Task 1: Define and Map the Study Area

This site is contained within the Wapato Creek Drainage Basin. The area of analysis extends from the site discharge point to approximately a quarter-mile downstream where stormwater runoff continues being conveyed through Wapato Creek. A Downstream Map is provided in Figure 7 below.

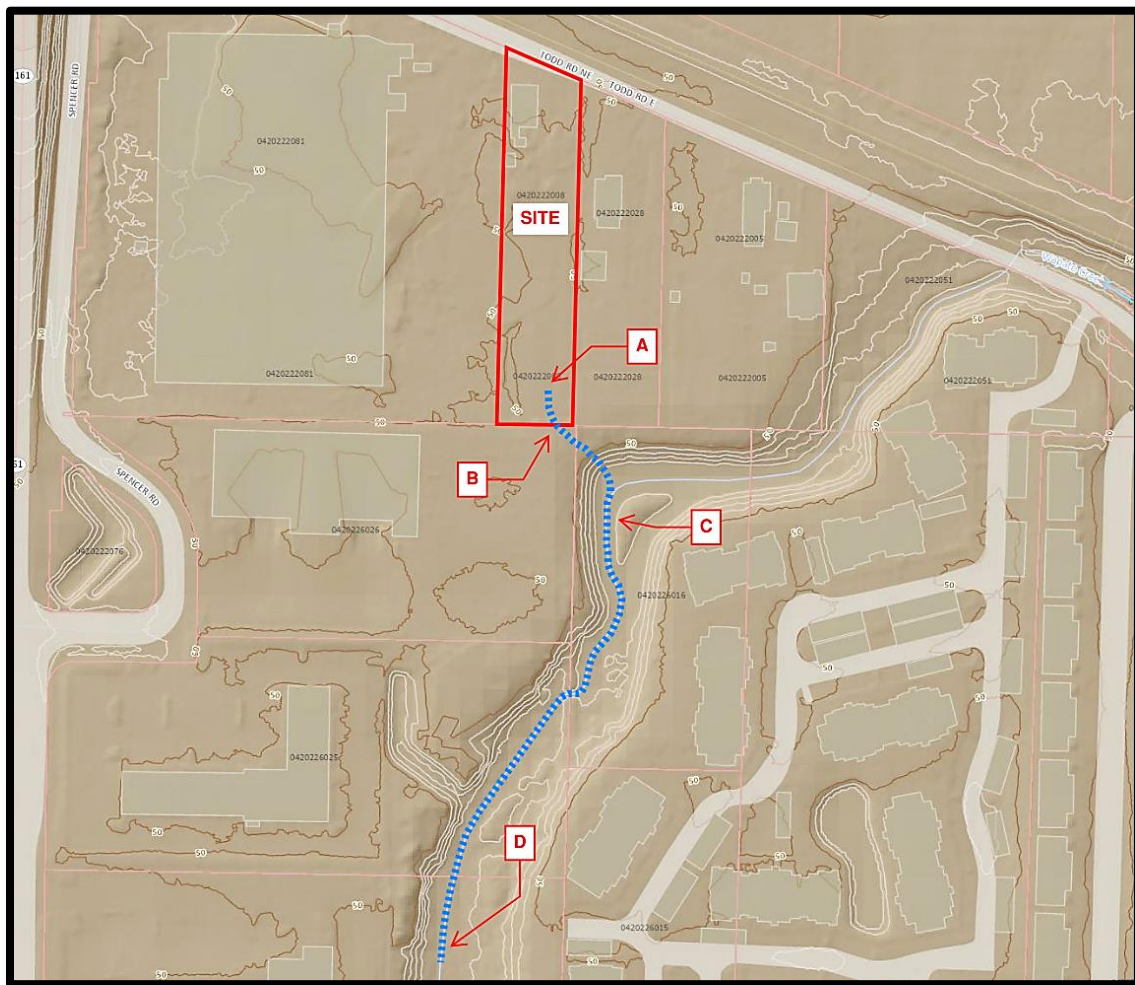

Figure 4: Downstream Map

Task 2: Review All Available Information on the Study Area

Per Pierce County resources, there have been no significant drainage complaints within a quarter mile downstream of the site. However, according to the Wetland and Stream Reconnaissance by Altmann Oliver Associates (Appendix B), there is a wetland associated with Wapato Creek located just southeast of the site.

Task 3: Field Inspect the Study Area

A field inspection was performed by Encompass Engineering & Surveying on February 23rd, 2021, at approximately 10:30pm. Please refer to Task 4 for a detailed description of the downstream drainage system and analysis.

Task 4: Describe the Drainage System and its existing and predicted problems

Stormwater runoff normally infiltrates into the onsite soils, but in the event of an extreme rain event it would sheet flow through a lawn/gravel areas (A) off the southern side of the site (B). This is the site's only Natural Discharge Area (NDA), which results in one Threshold Discharge Area (TDA). Once the stormwater runoff sheet flows toward the southern property line, it would begin to flow to the southeast for approximately 300 FT before eventually converging with Wapato Creek (C). Once entering Wapato Creek, the stormwater continues flowing to the south until the ¼ mile off-site limit is reached (D). This is where the offsite analysis was concluded.



Element A/B – Runoff sheet flows offsite to the south towards Wapato Creek



Element C –Runoff flow to the southeast for approximately 300 FT before eventually converging with Wapato Creek .

Table 1: Off-Site Analysis Drainage System

Symbol (see map)	Drainage Component Type	Drainage Component Description	Slope %	Distance from site discharge (¼ ml = 1,320 ft.)	Existing Problems	Potential Problems	Observations of field inspector, resource reviewer, or resident
A	SHEET FLOW	GRAVEL	0-2%	0'	NO	NO	NO IMMINENT PROBLEMS
B	SHEET FLOW	GRAVEL	0-2%	0'-400'	NO	NO	NO IMMINENT PROBLEMS
C	STREAM	WAPATO CREEK	N/A	400'	NO	NO	NO IMMINENT PROBLEMS

Task 5: Mitigation of Existing or Potential Problems

No relevant drainage complaints were identified within a quarter-mile of the site discharge location.

IV. PERMANENT STORMWATER CONTROL PLAN

Part A: Existing Site Hydrology

The 39,779 SF (0.91 AC) parcel is currently developed with a 1,653 SF (roof area) single-family residence, a 137 SF deck, and a 34,121 SF gravel storage yard.

Stormwater from the site generally sheet flows towards the southeastern property boundary across the site slopes of 0-2%. The project clearing limits have been modeled as 100% forest in the existing conditions model. Please refer to Figure 4 for an Existing Conditions Map.

Part B: Developed Site Hydrology

The project proposes mitigation of the 21,780 SF of all impervious surfaces. As this project proposes greater than 10,000 SF of impervious surface, flow control is required per Section I-3.4.7 of the 2019 SWMMWW. All impervious surfaces (21,780 SF) will be mitigated via a 48” CMP solid detention tank system (flow control facility) sized using WWHM. A Contech Filterra water quality system will be installed prior to detention. The detention system will be located in the southern portion of the site. Please refer to the Civil Plan Set for design details. Please refer to Appendix D for a copy of the full WWHM data output.

The Infiltration Evaluation by Earth Solutions NW, LLC (Appendix A) indicates that the native soil is a combination of silty sand and sandy silt, with the groundwater table encountered beginning at 5-5.5 FT below grade. The measured infiltration rate is 1.4 inches/hour, and the design infiltration rate is 0.3 inches/hour. Please refer to Appendix A for a copy of the Infiltration Evaluation.

The project clearing limits have been modeled as shown in Table 2 below.

Table 2: WWHM Area Breakdown

Condition	Existing		Developed	
	Measured	Modeled	Measured	Modeled
Forest, Flat:		37,437 SF (0.85 AC)		
Lawn/Flat:				15,657 (0.35 AC)
Roof, Flat:				10,195 SF (0.23 AC)
Walkways/Patios, Flat:				1,440 SF (0.03 AC)
Roads, Flat:				10,145 SF (0.24 AC)
Total Area:		37,437 SF (0.85 AC)	37,437 SF (0.85 AC)	37,437 SF (0.85 AC)

Part C: Performance Standards

Flow control facilities are required to meet the level 2 flow control standard. This requires that the predeveloped and developed discharge durations match for 50% of the 2-year peak flow up to the full 50-year peak flow. Please refer to Part D of this Section for further discussion.

The proposed development is considered a “Large Lot”; therefore, the site has been designed to comply with the Large Lot BMP Requirements detailed in Section 1.2.9.2.2 of the 2021 KCSWDM. Please refer to Core Requirement #9 in Section II of this TIR for further discussion.

Part D: Flow Control System

WWHM2012 was used to size the Contech CMP detention tank system for the site that meets the Conservation Flow Control standard. As shown in the WWHM2012 summary in Figure 8 below, the minimum required detention volume is 0.078 AC-FT (3,398 CF). In order to satisfy this requirement, the project proposes a infiltrating 48” diameter Contech CMP tank system with a storage volume of 3,430 CF to provide flow control for the site. As shown in the full WWHM output included in Appendix C, the proposed detention system meets the Conservation Flow control standard for discharge durations and peak discharge rates.

The screenshot displays the configuration for 'Contech CMP 1'. Key parameters include:

- Facility Name:** Contech CMP 1
- Downstream Connection:** Outlet 1 (0), Outlet 2 (0), Outlet 3 (0)
- Perforated CMP:** 48" diameter, 1 Manifold
- Outlet Structure Data:** Riser Height (4.5 ft), Riser Diameter (18 in), Riser Type (Flat), Notch Type
- Infiltration:** Measured Infiltration Rate (0.3 in/hr), Reduction Factor (1), Use Wetted Surface Area (sidewalls) (NO)
- Volume Calculations:** Total Volume Infiltrated (238.156 ac-ft), Total Volume Through Riser (22.509 ac-ft), Total Volume Through Facility (260.665 ac-ft), Percent Infiltrated (91.36%), Contech CMP Volume at Riser Head (0.078 ac-ft)

Figure 9: WWHM Detention Tank Information

Part E: Water Quality System

As this project proposes greater than 5,000 SF of pollution generating impervious surface, water quality is required ; therefore a Contech Filterra water quality system will be installed prior release stormwater into the detention system proposed to mitigate all impervious surfaces within the project.

V. CONVEYANCE SYSTEM ANALYSIS AND DESIGN

Conveyance system analysis and design is not warranted for this project.

VI. CONSTRUCTION STORMWATER POLLUTION PREVENTION PLAN (SWPPP)

1. Preserve Vegetation/Mark Clearing Limits
 - a. The clearing limits are shown on the TESC plans surrounding all proposed construction activity.
 - b. Retain the duff layer, native topsoil and natural vegetation in an undisturbed state to the maximum degree practicable.
2. Establish Construction Access
 - a. A stabilized construction entrance is shown for the project off of the alley.
 - b. If sediment is tracked off site, the affected roadways are to be cleaned thoroughly at the end of each day.
3. Control Sediment
 - a. The proposed sediment trap will be used to control flow rates during construction of the house and infrastructure improvements.
 - b. Silt fence will also be utilized to control sediment and protect adjacent properties.
4. Install Sediment Controls
 - a. The proposed sediment trap will be installed at the beginning of the project before major clearing and grading.
 - b. Silt fence will also be installed during the initial phase of construction.
5. Stabilize Soils
 - a. Stabilize expose and unworked soils. Soils must not remain exposed and unworked for more than the time periods set forth below to prevent erosion:
 - During the dry season (May 1 – September 30): 7 days
 - During the wet season (October 1 – April 30): 2 days
 - Stabilize soils at the end of the shift before a holiday or weekend if needed based on the weather forecast.
 - b. Stockpiled soils to be covered with plastic.
 - c. All disturbed areas shall be stabilized with landscaping or some other method prior to final construction approval.
6. Protect Slopes
 - a. Design and construct cut-and-fill slopes in a manner to minimize erosion.
7. Protect Drain Inlets
 - a. Protect storm drain inlets made operable during construction so that stormwater runoff does not enter the conveyance system without first being filtered or treated to remove sediment.
 - b. Clean or remove and replace inlet protection devices when sediment has filled one third of the available storage (unless a different standard is specified by the product manufacturer).
8. Stabilize Channels and Outlets
 - a. No channels or outlets are proposed.
9. Control Pollutants
 - a. Design, install, implement and maintain effective pollution prevention measures to minimize the discharge of pollutants.
 - b. Handle and dispose all pollutants, including waste materials and demolition debris that occur on-site in a manner that does not cause contamination of stormwater.

- c. Provide cover, containment, and protection from vandalism for all chemicals, liquid products, petroleum products, and other materials that have the potential to pose a threat to human health or the environment. On-site fueling tanks must include secondary containment. Secondary containment means placing tanks or containers within an impervious structure capable of containing 110% of the volume contained in the largest tank within the containment structure. Double-walled tanks do not require additional secondary containment.
 - d. Conduct maintenance, fueling and repair of heavy equipment and vehicles using spill prevention and control measures. Clean contaminated surfaces immediately following any spill incident.
 - e. Discharge wheel wash or tire bath wastewater to a separate on-site treatment system that prevents discharge to surface water, such as closed-loop recirculation or upland application, or to the sanitary sewer, with local sewer district approval.
 - f. Apply fertilizers and pesticides in a manner and at application rates that will not result in loss of chemical to stormwater runoff. Follow manufacturers' label requirements for application rates and procedures.
 - g. Use BMPs to prevent contamination of stormwater runoff by pH modifying sources. The sources for this contamination include, but are not limited to: bulk cement, cement kiln dust, fly ash, new concrete washing and curing waters, waste streams generated from concrete grinding and sawing, exposed aggregate processes, dewatering concrete vaults, concrete pumping and mixer washout waters.
 - h. Adjust the pH of stormwater if necessary to prevent violations of water quality standards.
 - i. Assure that washout of concrete trucks is performed off-site or in designated concrete washout areas only. Do not wash out concrete trucks onto the ground, or into storm drains, open ditches, streets, or streams. Do not dump excess concrete on-site, except in designated concrete washout areas. Concrete spillage or concrete discharge to surface waters of the State is prohibited.
 - j. Obtain written approval from Ecology before using chemical treatment other than CO₂ or dry ice to adjust pH.
10. Control Dewatering
 - a. Dewatering is not anticipated at this site.
 11. Maintain BMPs
 - a. Maintain and repair all temporary and permanent erosion and sediment control BMPs as needed to assure continued performance of their intended function in accordance with BMP specifications.
 - b. Remove all temporary erosion and sediment control BMPs within 30 days after achieving final site stabilization or after the temporary BMPs are no longer needed. All disturbed areas shall be stabilized with landscaping or some other method prior to final construction approval.
 12. Manage the Project
 - a. Maintain an updated SWPPP
 13. Protect Low Impact Development BMPs.

VII. SPECIAL REPORTS AND STUDIES

- Infiltration Evaluation by Earth Solutions NW, LLC (dated June 28, 2022)
- Wetland and Stream Reconnaissance by Altmann Oliver Associates, LLC (dated July 15, 2022)

VIII. OTHER PERMITS

- Building permits

IX. OPERATION AND MAINTENANCE MANUAL

An Operation and Maintenance Manual is included as Appendix C.

X. DECLARATION OF COVENANT OR EASEMENT FOR PRIVATELY MAINTAINED FLOW CONTROL AND TREATMENT FACILITIES

This document will be prepared and submitted if requested by the City of Puyallup.

XI. DECLARATION OF COVENANT OR EASEMENT FOR ON-SITE STORMWATER MANAGEMENT FACILITIES

This document will be prepared and submitted if requested by the City of Puyallup.

XII. BOND QUANTITIES WORKSHEET

Bond quantities will be prepared and submitted if requested by the City of Puyallup.

Appendix A

Infiltration Evaluation by Earth Solutions NW, LLC (dated June 28, 2022)



June 28, 2022
ES-8413

Earth Solutions NW LLC

Geotechnical Engineering, Construction
Observation/Testing and Environmental Services

American Pride Lending, LLC
P.O. Box 1226
Kent, Washington 98035

Attention: Mr. Sikander Sekhon

**Subject: Infiltration Evaluation
Proposed Site Improvements
212 Todd Road Northeast
Puyallup, Washington**

Reference: Department of Ecology, State of Washington
2014 Stormwater Management Manual for Western Washington (SMMWW)

Schuster, et al.
Geologic Map of Tacoma, November 2015

Dear Mr. Sekhon:

As requested, Earth Solutions NW, LLC (ESNW) has prepared this infiltration evaluation for the subject site.

Project Description

We understand low impact development flow control best management practices (BMPs) are being evaluated to control stormwater. Infiltration of stormwater is being evaluated as part of the overall stormwater design.

If the above design assumptions are incorrect or change, ESNW should be contacted to review the recommendations provided in this report. ESNW should review final designs to confirm that our geotechnical recommendations have been incorporated into project plans.

Surface

The subject site is located at 212 Todd Road Northeast in Puyallup, Washington, as illustrated on the attached Vicinity Map (Plate 1). The site consists of one tax parcel (Pierce County parcel number 2354300575). The site is currently developed a single-family residence in the northwest corner of the property; the remainder of the property is covered with gravel. The site topography is relatively level.

Subsurface

An ESNW representative observed, logged, and sampled five test pits, excavated at accessible locations within the property boundaries, on March 7, 2022 using a mini-trackhoe and operator provided by our firm. Shallow groundwater monitoring wells were installed within test pits TP-3, TP-4, and TP-5. The approximate locations of the test pits are depicted on the attached Plate 2 (Test Pit Location Plan). Please refer to the test pit logs provided as attachments for a more detailed description of subsurface conditions. Representative soil samples collected at the test pit locations were evaluated in general accordance with Unified Soil Classification System (USCS) and USDA methods and procedures.

Fill

Existing gravel fill was encountered at all test pit locations extending to about one foot below the existing ground surface (bgs). The gravel fill was associated with the gravel-surfacing material observed throughout the majority of the site.

Native Soil

Underlying surficial existing fill, native soil was encountered primarily as loose to medium dense silty sand and sandy silt (USCS: SM and ML, respectively). Caving within the test pits was observed, beginning at depths of about three and one-half to seven and one-half feet bgs. The native soil was generally observed to be in a wet condition.

Geologic Setting

The referenced geologic map identifies alluvium deposits throughout the site and surrounding area. According to the geologic map resource, alluvium deposits are loose, stratified to massively bedded fluvial silt, sand, and gravel. Based on our field observations, native soil likely to be exposed on site will be consistent with alluvium deposits.

Groundwater

The local groundwater table was observed beginning at depths of about five to five and one-half feet bgs during the fieldwork on March 7, 2022. It is likely that the local groundwater table rises a foot or two throughout the peak of the wet season; ESNW can complete seasonal groundwater level monitoring upon request. Groundwater flow rates and elevations fluctuate depending on many factors, including precipitation duration and intensity, the time of year, and soil conditions. In general, groundwater flow rates are higher during the winter, spring, and early summer months.

Infiltration Evaluation

Our evaluation of site infiltration capacity was completed by excavating a series of test pits throughout the site, and completing two small-scale pilot infiltration tests (PITs). As indicated in the *Subsurface* section of this report, native soils encountered during our fieldwork were characterized primarily as silty sand and sandy silt, with the groundwater table encountered beginning at about five to five and one-half feet bgs.

PITs were performed within TP-1 and TP-2 at a depth of roughly four feet bgs; the measured infiltration rates were 4.2 and 1.4 inches per hour, respectively. For preliminary design purposes, we recommend assuming a measured infiltration rate of 1.4 inches per hour. The measured rate must be reduced by the following correction factors:

- Measured infiltration rate 1.4 inches per hour
- Site variability (CF_v) 0.5
- Test method (CF_t) 0.5
- Degree of influent control (CF_m) 0.9

The correction factors, along with the measured infiltration rate, were applied to determine the design infiltration rate. Based on our in-situ test results, it is our opinion the following infiltration rate can be used for preliminary design purposes if pursued:

- Design infiltration rate 0.3 inches per hour

If infiltration is pursued, the facilities will need to maintain proper separation from the local groundwater table. Depending on total impervious area proposed to be directed to infiltration facilities, additional PITs may be necessary.

ESNW can provide further evaluation and recommendations for site BMPs as plans develop. ESNW should review final stormwater management plans to provide supplementary recommendations, as needed.

Limitations

The recommendations and conclusions provided in this letter are professional opinions consistent with the level of care and skill that is typical of other members in the profession currently practicing under similar conditions in this area. A warranty is not expressed or implied. Variations in the soil and groundwater conditions observed at the test sites may exist and may not become evident until construction. ESNW should reevaluate the conclusions in this letter if variations are encountered.

Additional Services

ESNW can complete additional PITs and seasonal groundwater level monitoring upon request. ESNW should have an opportunity to review the final design with respect to the geotechnical recommendations provided in this letter. ESNW should also be retained to provide testing and consultation services during the earthwork phase of construction.

We trust this letter meets your current needs. Should you have questions regarding the content herein, or require additional information, please call.

Sincerely,

EARTH SOLUTIONS NW, LLC



06/28/2022

Henry T. Wright, P.E.
Associate Principal Engineer

Attachments: Plate 1 – Vicinity Map
Plate 2 – Test Pit Location Plan
Test Pit Logs
Grain Size Distribution

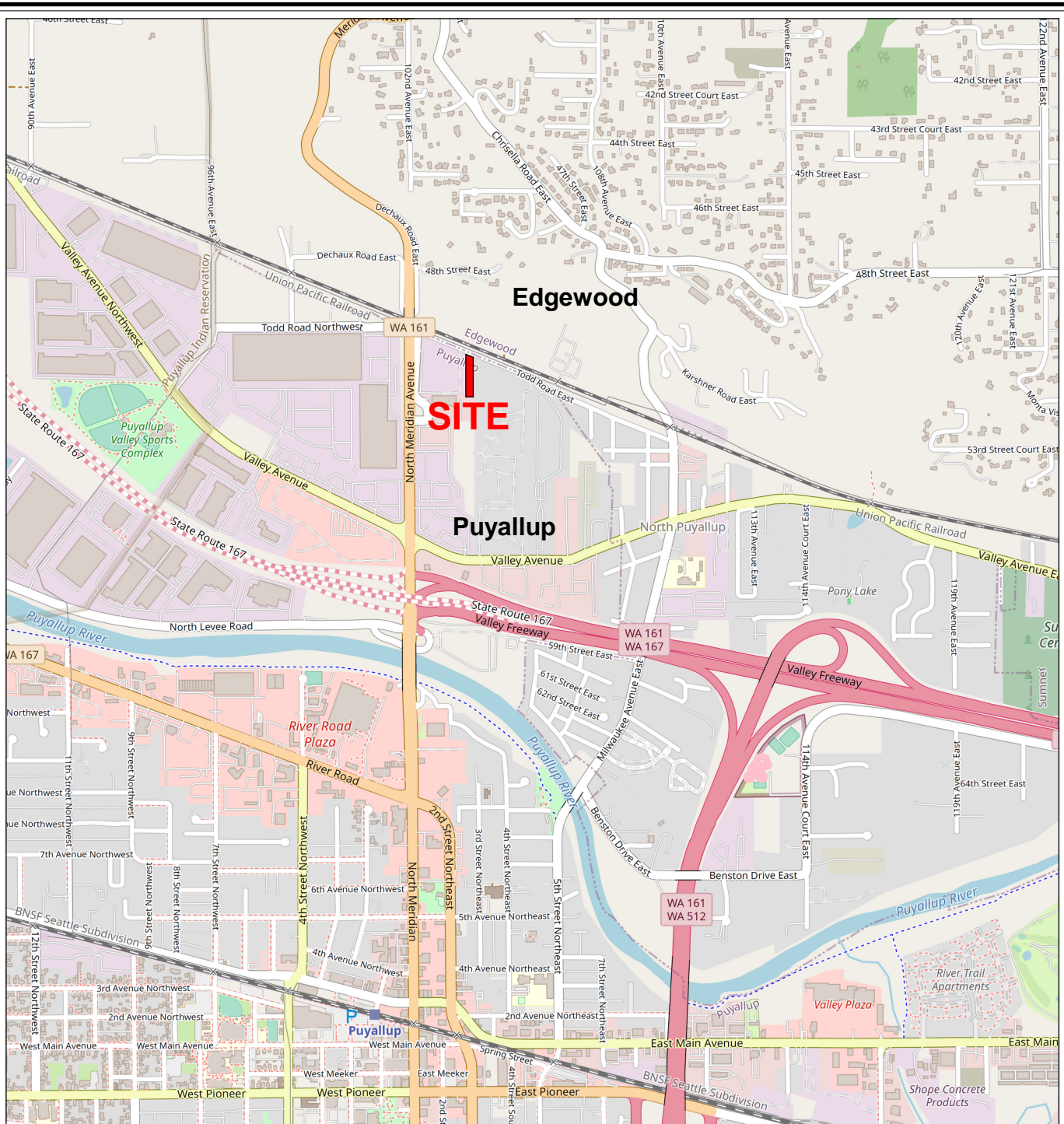

Reference:
Pierce County, Washington
OpenStreetMap.org



Earth Solutions NW_{LLC}
Geotechnical Engineering, Construction
Observation/Testing and Environmental Services



Vicinity Map
212 Todd Road N.E.
Puyallup, Washington

NOTE: This plate may contain areas of color. ESNW cannot be responsible for any subsequent misinterpretation of the information resulting from black & white reproductions of this plate.

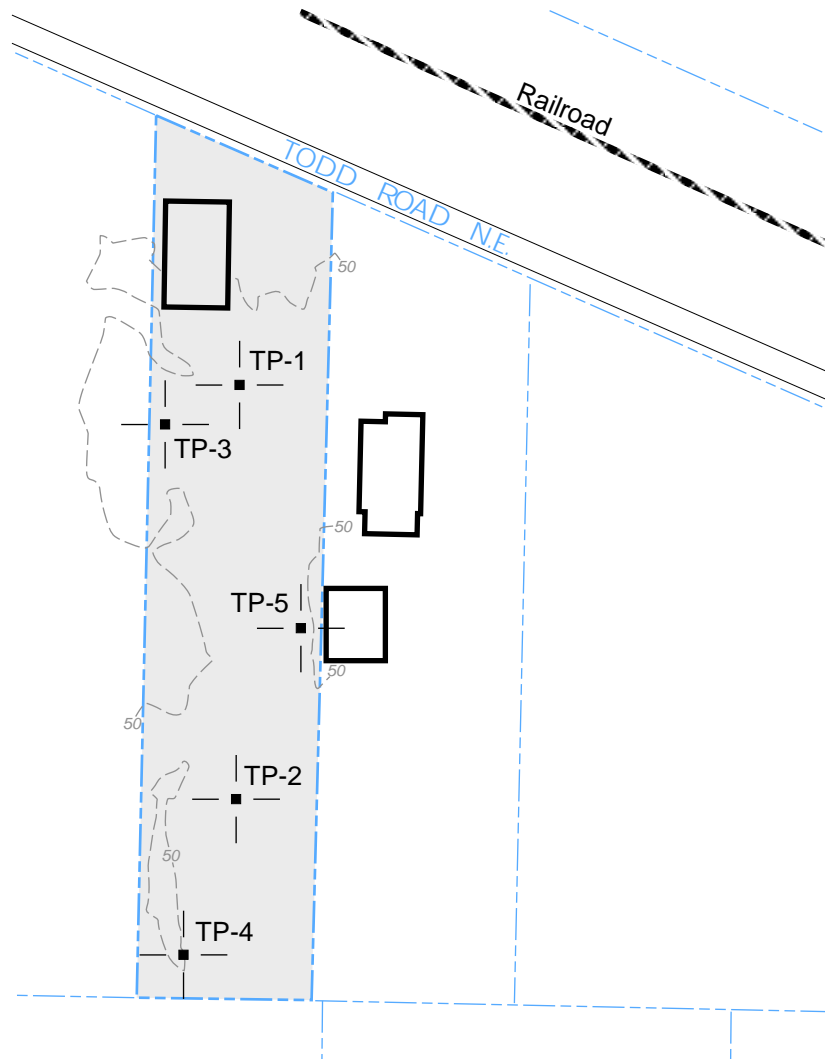
Drwn. CAM	Date 05/24/2022	Proj. No. 8413
Checked SES	Date May 2022	Plate 1

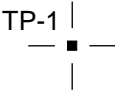
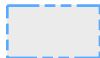

LEGEND

- 
 TP-1 | Approximate Location of ESNW Test Pit, Proj. No. ES-8413, March 2022
- 
 Subject Site
- 
 Existing Building

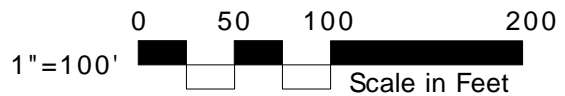

NOTE: The graphics shown on this plate are not intended for design purposes or precise scale measurements, but only to illustrate the approximate test locations relative to the approximate locations of existing and / or proposed site features. The information illustrated is largely based on data provided by the client at the time of our study. ESNW cannot be responsible for subsequent design changes or interpretation of the data by others.

NOTE: This plate may contain areas of color. ESNW cannot be responsible for any subsequent misinterpretation of the information resulting from black & white reproductions of this plate.



Earth Solutions NW_{LLC}









Geotechnical Engineering, Construction
Observation/Testing and Environmental Services

Test Pit Location Plan
212 Todd Road N.E.
Puyallup, Washington

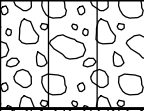
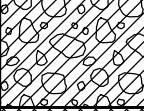
Drwn. CAM	Date 05/24/2022	Proj. No. 8413
Checked SES	Date May 2022	Plate 2

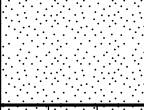
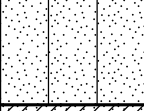
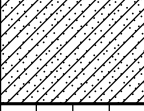
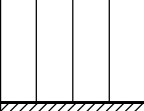
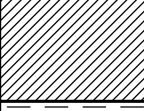
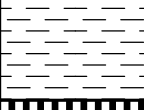
Earth Solutions NW_{LLC}

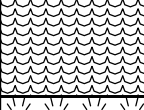
SOIL CLASSIFICATION CHART

MAJOR DIVISIONS			SYMBOLS		TYPICAL DESCRIPTIONS
			GRAPH	LETTER	
COARSE GRAINED SOILS MORE THAN 50% OF MATERIAL IS LARGER THAN NO. 200 SIEVE SIZE	GRAVEL AND GRAVELLY SOILS (LITTLE OR NO FINES)	CLEAN GRAVELS		GW	WELL-GRADED GRAVELS, GRAVEL - SAND MIXTURES, LITTLE OR NO FINES
		(LITTLE OR NO FINES)		GP	POORLY-GRADED GRAVELS, GRAVEL - SAND MIXTURES, LITTLE OR NO FINES
		GRAVELS WITH FINES		GM	SILTY GRAVELS, GRAVEL - SAND - SILT MIXTURES
	MORE THAN 50% OF COARSE FRACTION RETAINED ON NO. 4 SIEVE (APPRECIABLE AMOUNT OF FINES)	GRAVELS WITH FINES		GC	CLAYEY GRAVELS, GRAVEL - SAND - CLAY MIXTURES
		(APPRECIABLE AMOUNT OF FINES)		SW	WELL-GRADED SANDS, GRAVELLY SANDS, LITTLE OR NO FINES
		CLEAN SANDS		SP	POORLY-GRADED SANDS, GRAVELLY SAND, LITTLE OR NO FINES
	SAND AND SANDY SOILS (LITTLE OR NO FINES)	CLEAN SANDS		SM	SILTY SANDS, SAND - SILT MIXTURES
		(LITTLE OR NO FINES)		SC	CLAYEY SANDS, SAND - CLAY MIXTURES
		SANDS WITH FINES		ML	INORGANIC SILTS AND VERY FINE SANDS, ROCK FLOUR, SILTY OR CLAYEY FINE SANDS OR CLAYEY SILTS WITH SLIGHT PLASTICITY
FINE GRAINED SOILS MORE THAN 50% OF MATERIAL IS SMALLER THAN NO. 200 SIEVE SIZE	SILTS AND CLAYS LIQUID LIMIT LESS THAN 50	(LITTLE OR NO FINES)		CL	INORGANIC CLAYS OF LOW TO MEDIUM PLASTICITY, GRAVELLY CLAYS, SANDY CLAYS, SILTY CLAYS, LEAN CLAYS
		(APPRECIABLE AMOUNT OF FINES)		OL	ORGANIC SILTS AND ORGANIC SILTY CLAYS OF LOW PLASTICITY
		SANDS WITH FINES		MH	INORGANIC SILTS, MICACEOUS OR DIATOMACEOUS FINE SAND OR SILTY SOILS
	SILTS AND CLAYS LIQUID LIMIT GREATER THAN 50	(LITTLE OR NO FINES)		CH	INORGANIC CLAYS OF HIGH PLASTICITY
		(APPRECIABLE AMOUNT OF FINES)		OH	ORGANIC CLAYS OF MEDIUM TO HIGH PLASTICITY, ORGANIC SILTS
		SANDS WITH FINES		PT	PEAT, HUMUS, SWAMP SOILS WITH HIGH ORGANIC CONTENTS
HIGHLY ORGANIC SOILS				PT	PEAT, HUMUS, SWAMP SOILS WITH HIGH ORGANIC CONTENTS

DUAL SYMBOLS are used to indicate borderline soil classifications.

The discussion in the text of this report is necessary for a proper understanding of the nature of the material presented in the attached logs.







Earth Solutions NW, LLC
 15365 N.E. 90th Street, Suite 100
 Redmond, Washington 98052
 Telephone: 425-449-4704
 Fax: 425-449-4711

TEST PIT NUMBER TP-1

PAGE 1 OF 1

PROJECT NUMBER ES-8413 PROJECT NAME 212 Todd Road N.E.
 DATE STARTED 3/7/22 COMPLETED 3/7/22 GROUND ELEVATION _____
 EXCAVATION CONTRACTOR NW Excavating LATITUDE _____ LONGITUDE _____
 EXCAVATION METHOD _____ GROUND WATER LEVEL:
 LOGGED BY SES CHECKED BY HTW ∇ AT TIME OF EXCAVATION 5.0 ft
 NOTES Surface Conditions: gravel pad

DEPTH (ft)	SAMPLE TYPE NUMBER	TESTS	U.S.C.S.	GRAPHIC LOG	MATERIAL DESCRIPTION
0.0					
			GP		Gray poorly graded GRAVEL, loose, damp (Fill) -fabric at contact
2.5		MC = 27.0% OC = 4.4%			Dark brown silty SAND, loose to medium dense, wet
5.0		MC = 27.2% Fines = 48.6%	SM		-infiltration test at 4' [USDA Classification: slightly gravelly very fine sandy LOAM] -becomes wet ∇ -groundwater table
7.5					-slight caving to BOH
10.0		MC = 32.6% Fines = 30.5%			[USDA Classification: fine sandy LOAM]

Test pit terminated at 10.0 feet below existing grade. Groundwater table encountered at 5.0 feet during excavation. Caving observed from 7.5 feet to BOH.

GENERAL BH / TP / WELL - 8413.GPJ - GRAPHICS TEMPLATE WITH LAT AND LONG.GDT - 5/24/22



Earth Solutions NW, LLC
 15365 N.E. 90th Street, Suite 100
 Redmond, Washington 98052
 Telephone: 425-449-4704
 Fax: 425-449-4711

TEST PIT NUMBER TP-2

PAGE 1 OF 1

PROJECT NUMBER ES-8413 PROJECT NAME 212 Todd Road N.E.
 DATE STARTED 3/7/22 COMPLETED 3/7/22 GROUND ELEVATION _____
 EXCAVATION CONTRACTOR NW Excavating LATITUDE _____ LONGITUDE _____
 EXCAVATION METHOD _____ GROUND WATER LEVEL:
 LOGGED BY SES CHECKED BY HTW ∇ AT TIME OF EXCAVATION 5.0 ft
 NOTES Surface Conditions: gravel pad

DEPTH (ft)	SAMPLE TYPE NUMBER	TESTS	U.S.C.S.	GRAPHIC LOG	MATERIAL DESCRIPTION
0.0					
			GP		Gray poorly graded GRAVEL, loose, damp (Fill)
2.5		MC = 35.6% OC = 6.2%			Dark brown silty SAND, loose to medium dense, wet
5.0		MC = 28.4% Fines = 42.9%	SM		-infiltration test at 4', becomes wet [USDA Classification: slightly gravelly very fine sandy LOAM]
				∇	-groundwater table
7.5					Dark brown sandy SILT, loose to medium dense, wet
			ML		-slight caving to BOH
10.0		MC = 44.4% Fines = 98.4%			[USDA Classification: slightly gravelly LOAM]

Test pit terminated at 10.0 feet below existing grade. Groundwater table encountered at 5.0 feet during excavation. Caving observed from 7.0 feet to BOH.

GENERAL BH / TP / WELL - 8413.GPJ - GRAPHICS TEMPLATE WITH LAT AND LONG.GDT - 5/24/22





Earth Solutions NW, LLC
 15365 N.E. 90th Street, Suite 100
 Redmond, Washington 98052
 Telephone: 425-449-4704
 Fax: 425-449-4711

TEST PIT NUMBER TP-3

PAGE 1 OF 1

PROJECT NUMBER ES-8413 PROJECT NAME 212 Todd Road N.E.
 DATE STARTED 3/7/22 COMPLETED 3/7/22 GROUND ELEVATION _____
 EXCAVATION CONTRACTOR NW Excavating LATITUDE _____ LONGITUDE _____
 EXCAVATION METHOD _____ GROUND WATER LEVEL:
 LOGGED BY SES CHECKED BY HTW ∇ AT TIME OF EXCAVATION 5.5 ft
 NOTES Surface Conditions: gravel pad

DEPTH (ft)	SAMPLE TYPE NUMBER	TESTS	U.S.C.S.	GRAPHIC LOG	MATERIAL DESCRIPTION
0.0					
			GP		Gray poorly graded GRAVEL, loose, damp (Fill)
2.5		MC = 18.9%	SM		Dark brown silty SAND, loose to medium dense, wet
5.0					
7.5		MC = 37.9%	ML		Dark brown sandy SILT, loose to medium dense, wet ∇ -groundwater table, moderate caving to BOH -mottled texture
		MC = 34.6%			

Test pit terminated at 9.5 feet below existing grade. Groundwater table encountered at 5.5 feet during excavation. Caving observed from 5.5 feet to BOH.



GENERAL BH / TP / WELL - 8413.GPJ - GRAPHICS TEMPLATE WITH LAT AND LONG.GDT - 5/24/22



Earth Solutions NW, LLC
 15365 N.E. 90th Street, Suite 100
 Redmond, Washington 98052
 Telephone: 425-449-4704
 Fax: 425-449-4711

TEST PIT NUMBER TP-4

PROJECT NUMBER ES-8413 PROJECT NAME 212 Todd Road N.E.
 DATE STARTED 3/7/22 COMPLETED 3/7/22 GROUND ELEVATION _____
 EXCAVATION CONTRACTOR NW Excavating LATITUDE _____ LONGITUDE _____
 EXCAVATION METHOD _____ GROUND WATER LEVEL:
 LOGGED BY SES CHECKED BY HTW ∇ AT TIME OF EXCAVATION 5.0 ft
 NOTES Surface Conditions: gravel pad

DEPTH (ft)	SAMPLE TYPE NUMBER	TESTS	U.S.C.S.	GRAPHIC LOG	MATERIAL DESCRIPTION
0.0					
			GP		Gray poorly graded GRAVEL, loose, damp (Fill)
2.5		MC = 24.6%	SM		Brown silty SAND, loose to medium dense, wet
5.0		MC = 41.1%	ML		Dark brown sandy SILT, loose to medium dense, wet ∇ -mottled texture ∇ -groundwater table -slight caving to BOH
7.5					
10.0		MC = 33.6%			

Test pit terminated at 10.0 feet below existing grade. Groundwater table encountered at 5.0 feet during excavation. Caving observed from 6.5 feet to BOH.

GENERAL BH / TP / WELL - 8413.GPJ - GRAPHICS TEMPLATE WITH LAT AND LONG.GDT - 5/24/22



Earth Solutions NW, LLC
 15365 N.E. 90th Street, Suite 100
 Redmond, Washington 98052
 Telephone: 425-449-4704
 Fax: 425-449-4711

TEST PIT NUMBER TP-5

PAGE 1 OF 1

PROJECT NUMBER ES-8413 PROJECT NAME 212 Todd Road N.E.
 DATE STARTED 3/7/22 COMPLETED 3/7/22 GROUND ELEVATION _____
 EXCAVATION CONTRACTOR NW Excavating LATITUDE _____ LONGITUDE _____
 EXCAVATION METHOD _____ GROUND WATER LEVEL:
 LOGGED BY SES CHECKED BY HTW ∇ AT TIME OF EXCAVATION 5.0 ft
 NOTES Surface Conditions: gravel pad

DEPTH (ft)	SAMPLE TYPE NUMBER	TESTS	U.S.C.S.	GRAPHIC LOG	MATERIAL DESCRIPTION
0.0					
			GP		Gray poorly graded GRAVEL, loose, damp (Fill)
		MC = 23.8%			Brown silty SAND, loose to medium dense, wet
2.5			SM		-slight caving to BOH
					∇ -groundwater table
5.0		MC = 37.2%			Dark brown sandy SILT, loose to medium dense, wet
7.5			ML		
10.0		MC = 34.2%			

Test pit terminated at 10.0 feet below existing grade. Groundwater table encountered at 5.0 feet during excavation. Caving observed from 3.0 feet to BOH.

GENERAL BH / TP / WELL - 8413.GPJ - GRAPHICS TEMPLATE WITH LAT AND LONG.GDT - 5/24/22



Earth Solutions NW, LLC
 15365 N.E. 90th Street, Suite 100
 Redmond, Washington 98052
 Telephone: 425-449-4704
 Fax: 425-449-4711

GRAIN SIZE DISTRIBUTION

PROJECT NUMBER ES-8413

PROJECT NAME 212 Todd Road N.E

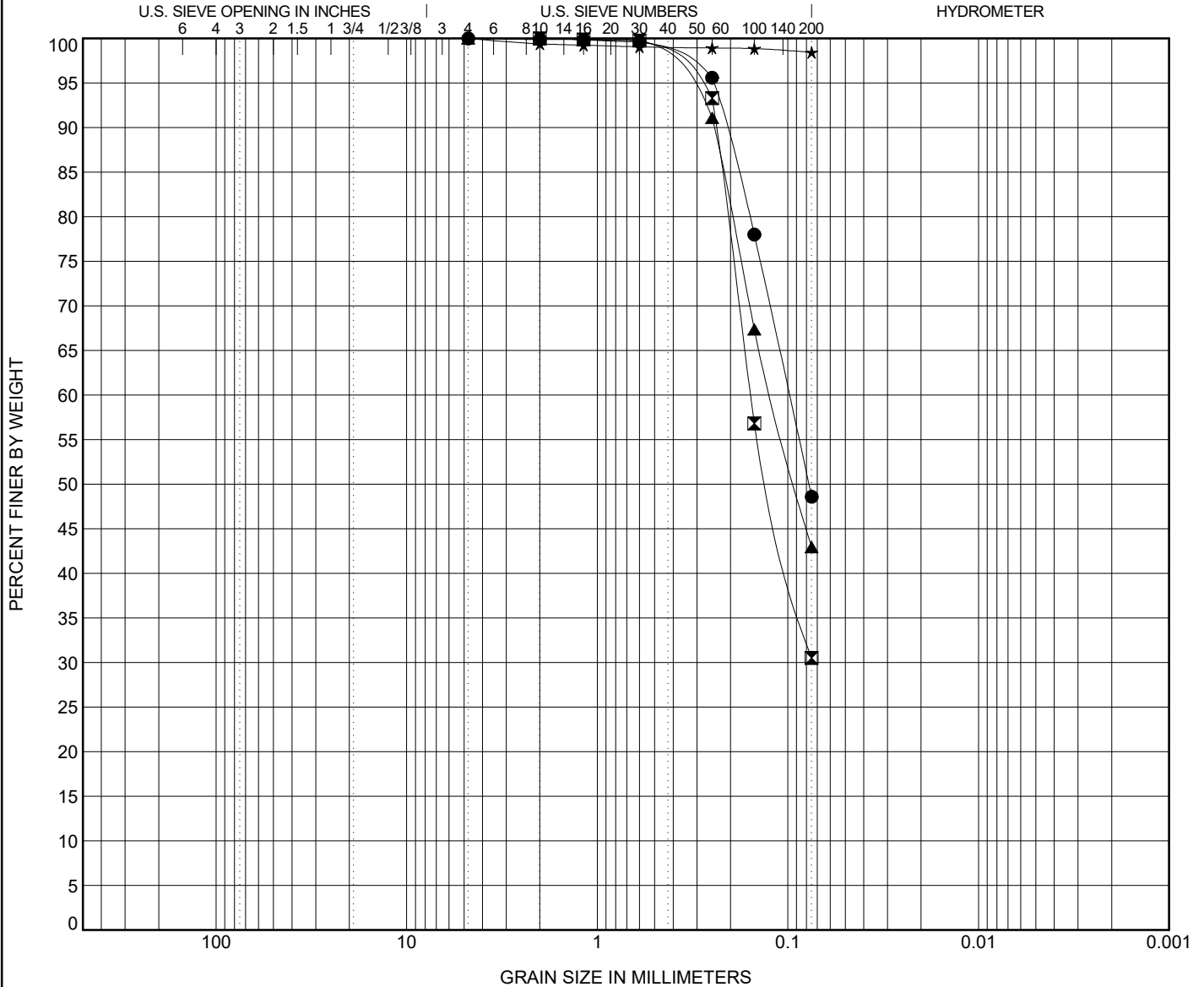

COBBLES	GRAVEL		SAND			SILT OR CLAY
	coarse	fine	coarse	medium	fine	

Specimen Identification	Classification							Cc	Cu
● TP-01 4.00ft.	USDA: Dk Brown Slightly Gravelly Very Fine Sandy Loam. USCS: SM.								
☒ TP-01 10.00ft.	USDA: Dk Brown Fine Sandy Loam. USCS: SM.								
▲ TP-02 4.00ft.	USDA: Dk Brown Slightly Gravelly Very Fine Sandy Loam. USCS: SM.								
★ TP-02 10.00ft.	USDA: Dk Brown Slightly Gravelly Loam. USCS: ML.								

Specimen Identification	D100	D60	D30	D10	LL	PL	PI	%Silt	%Clay
● TP-01 4.0ft.	4.75	0.098						48.6	
☒ TP-01 10.0ft.	2	0.157						30.5	
▲ TP-02 4.0ft.	4.75	0.122						42.9	
★ TP-02 10.0ft.	4.75							98.4	

GRAIN SIZE USDA ES-8413 212 TODD ROAD N.E.GPJ GINT US LAB.GDT 3/10/22

Appendix B

Wetland and Stream Reconnaissance by Altmann Oliver Associates, LLC (dated
July 15, 2022)

Altmann Oliver Associates, LLC

AOA



PO Box 578

Carnation, WA 98014

Office (425) 333-4535

Fax (425) 333-4509

Environmental
Planning &
Landscape
Architecture

July 15, 2022

AOA-6739

Amy Donlan
ADonlan@encompasses.net

**SUBJECT: Wetland and Stream Reconnaissance for 212 Todd Road NE
Parcel 042022-2008, Puyallup, WA (P-21-0146)**

Dear Amy:

On March 1, 2022 I conducted an initial wetland and stream reconnaissance on and adjacent to the subject property utilizing the methodology outlined in the May 2010 *Regional Supplement to the Corps of Engineers Wetland Delineation Manual: Western Mountains, Valleys, and Coast Region (Version 2.0)*. An additional field investigation was conducted by AOA on June 23, 2022.

At the time of the field investigations the property was entirely graveled except for a small house in the northwest corner of the site. Topography is flat and no significant native plant communities or wetlands are located on the property.

Wapato Creek flows from north to south off-site to the southeast. Although access was very limited, a narrow Riverine wetland (Wetland A) was observed in places along the creek. However, no wetlands were observed adjacent the creek in the area in closest proximity to the subject property. **Attachment A** contains a data sheet prepared for the off-site upland area immediately adjacent the creek within closest proximity to the property.

WAPATO CREEK AND WETLAND A

Wapato Creek is known to support salmonids and would therefore be considered a Type II stream by the City of Puyallup. Type II streams require a minimum standard buffer of 100 feet per PMC 21.06.1050(2)(b). Wetland A consists of a narrow Riverine Hydrogeomorphic (HGM) class wetland. Vegetation within Wetland A and the riparian corridor of Wapato Creek in the vicinity of the site consisted primarily of a forested plant community that included red alder (*Alnus rubra*), Pacific willow (*Salix lasiandra*), Himalayan blackberry (*Rubus armeniacus*), climbing nightshade (*Solanum dulcamara*), and English ivy (*Hedera helix*).

Amy Donlan
July 15, 2022
Page 2 of 2

Wetland A meets the criteria for a Category II wetland with 6 Habitat Points per the current City of Puyallup rating system (**Attachment B**). Category II wetlands with 6 Habitat Points require a standard 150-foot buffer adjacent high intensity land uses per PMC 21.06.930(2)(c). However, since Wetland A is not located adjacent to the creek in proximity to the site, it appears the Wapato Creek buffer would be more restrictive.

BUFFER RESTORATION

The City of Puyallup requires that the minimum critical area buffer be vegetated with native species as part of any proposed project. Since the 100-foot Wapato Creek buffer extends into the subject property (see survey) and the buffer area is currently gravel, a buffer restoration planting plan will be required as part of a proposed site plan.

If you have any questions regarding the reconnaissance, please give me a call.

Sincerely,

ALTMANN OLIVER ASSOCIATES, LLC

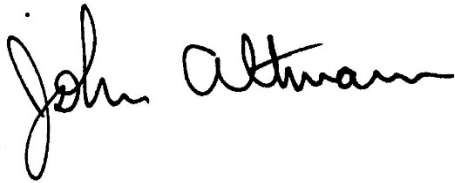
A handwritten signature in black ink that reads "John Altmann". The signature is written in a cursive, flowing style.

John Altmann
Ecologist

Attachments

City of Puyallup
Parcel 042022-2008

AOA-6739

Critical Areas Map

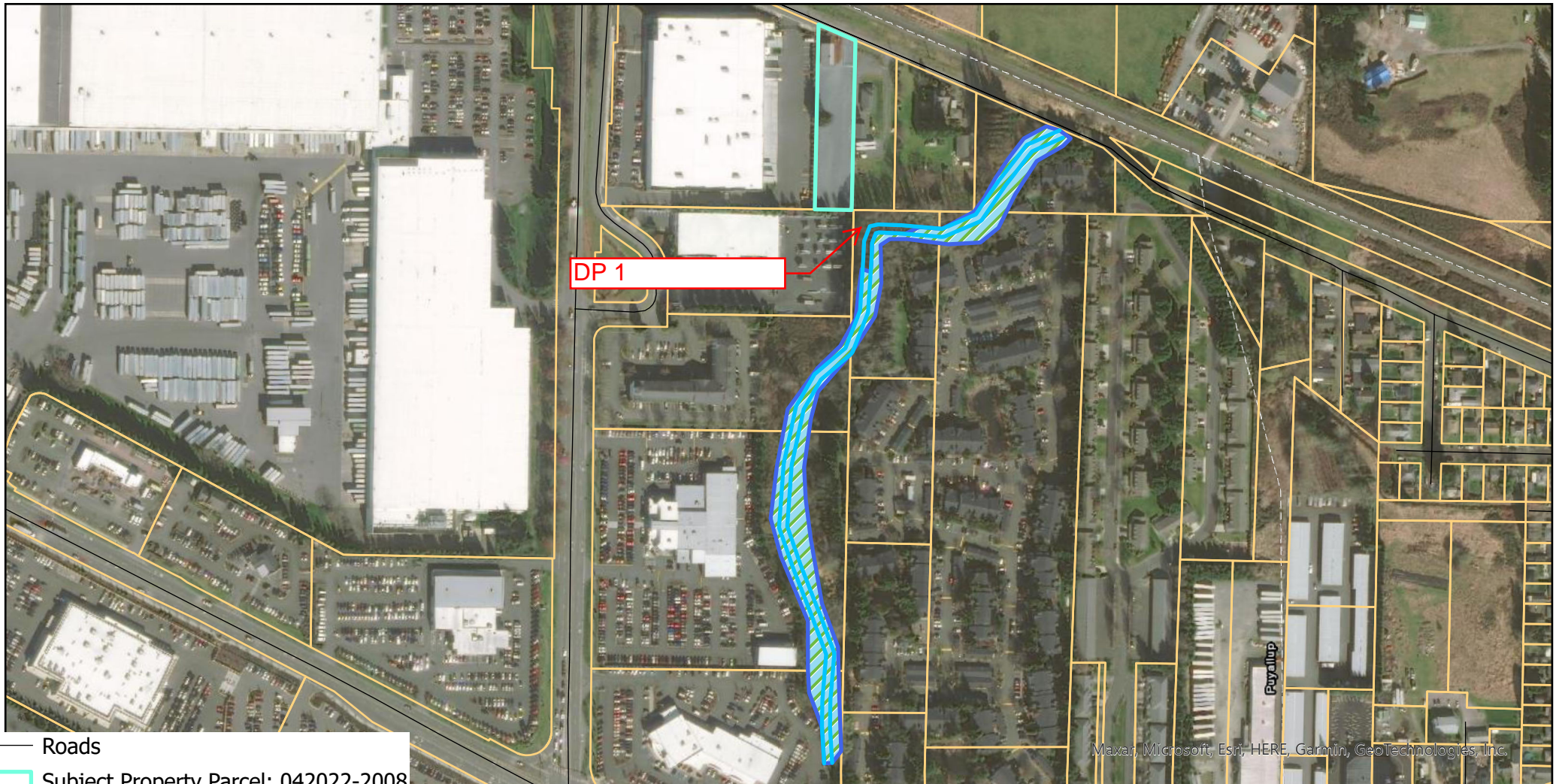

AMERICAN PRIDE LENDING, LLC

A PORTION OF THE NW 1/4 OF THE NW 1/4 OF SEC. 22, T 20 N., R 04 E., W.M.
PIERCE COUNTY, STATE OF WASHINGTON

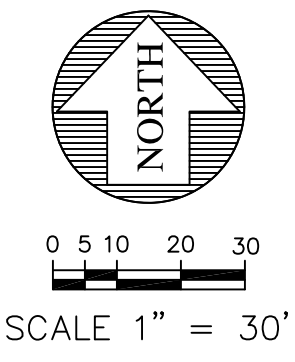
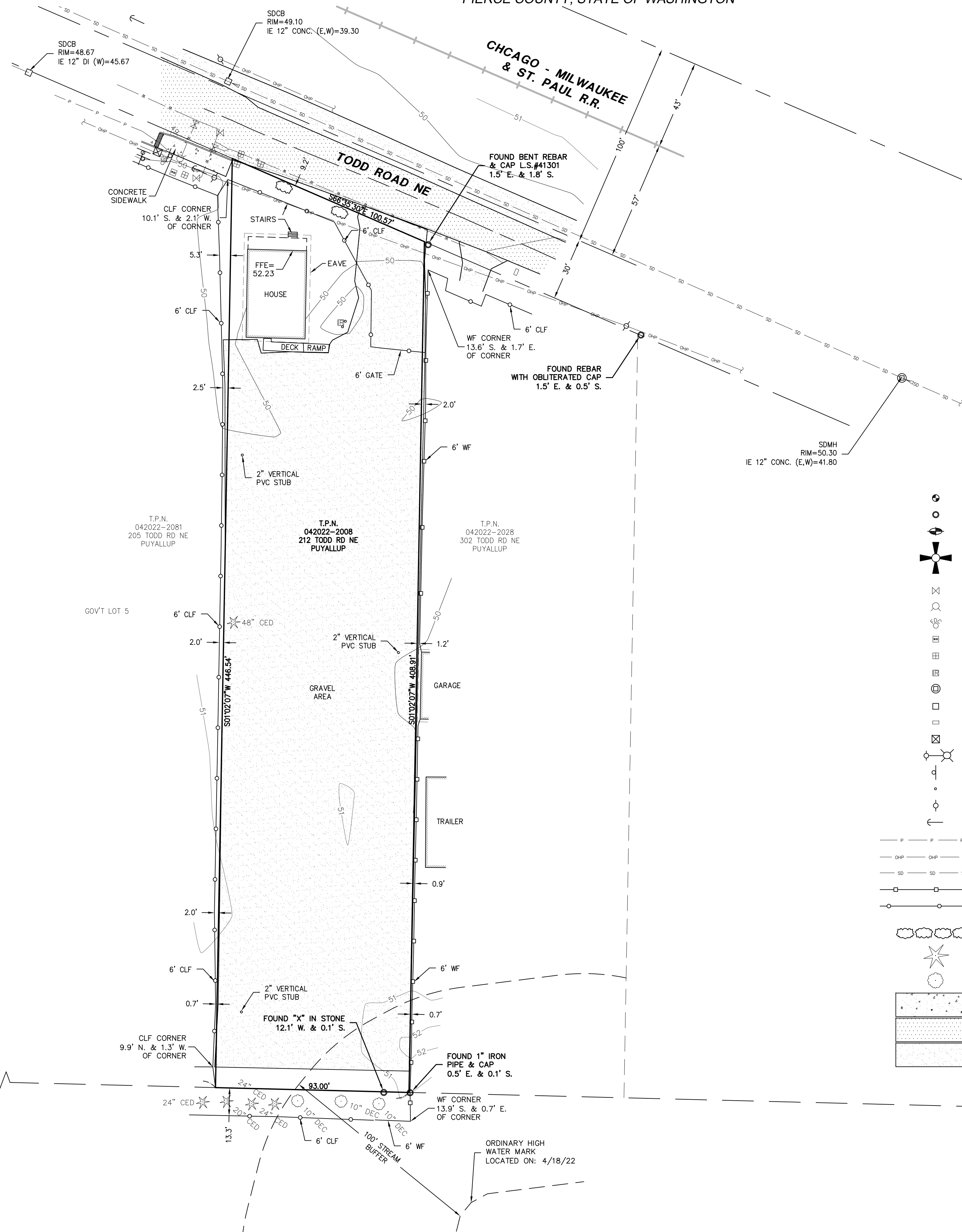

LEGEND

- FOUND MONUMENT IN CASE
- FOUND REBAR & CAP
- BENCHMARK
- SECTION CORNER
- WATER VALVE
- FIRE HYDRANT
- FIRE DEPARTMENT CONNECTION
- WATER VALVE BOX
- WATER METER
- IRRIGATION CONTROL VALVE
- STORM MANHOLE
- CATCH BASIN
- MAILBOX
- JUNCTION BOX
- LIGHT POLE
- SIGN POST
- POST
- UTILITY POLE
- GUY ANCHOR
- UNDERGROUND POWER LINE
- OVERHEAD POWER LINE
- STORM LINE
- WOOD FENCE (WF)
- CHAIN LINK FENCE (CLF)
- HEDGE LINE
- EVERGREEN TREE
- DECIDUOUS TREE
- CONCRETE
- ASPHALT
- GRAVEL

TAX PARCEL

042022-2008

VERTICAL DATUM

NAVD 88

BENCHMARK

HELD CITY OF PUYALLUP BENCHMARK NW-TODD 7
CONVERTED NGVD 29 ELEVATION OF 39.68' TO NAVD 88
ELEVATION OF 43.17 BY ADDING THE 3.49' PER CORPSCON
DATA CONVERSION SOFTWARE

HORIZONTAL DATUM

NAD 83/(2011) WASHINGTON SOUTH ZONE PER THE
WASHINGTON STATE REFERENCE NETWORK - CHECKED TO
PIERCE COUNTY REFERENCE NETWORK VIA TIES TO FOUND
MONUMENTS SM 3572 AND SM 3662

BASIS OF BEARINGS

HELD A BEARING OF S 01°02'07" W ALONG THE WEST LINE
OF GOV'T LOT 5 FROM THE FOUND MONUMENT AT THE NW
CORNER THEREOF TO A MONUMENT LOCATED ALONG THE
EXTENSION OF SAID WEST LINE LOCATED AT THE CENTER OF
INTERSECTION OF MERIDIAN AVE AND SPENCER RD E

INSTRUMENTATION

INSTRUMENT USED: 5 SECOND TOTAL STATION.
FIELD SURVEY WAS BY CLOSED TRAVERSE LOOPS, MINIMUM
CLOSURE OF LOOPS WAS 1:22,000, IN ACCORDANCE WITH
WAC 332-130-090.

LEGAL DESCRIPTION

BEGINNING AT A POINT 683 FEET EAST OF THE SOUTHWEST
CORNER OF LOT 5 IN SECTION 22, TOWNSHIP 20 NORTH,
RANGE 4 EAST OF THE WILLAMETTE MERIDIAN;
THENCE NORTH PARALLEL WITH THE WEST BOUNDARY OF
SAID LOT, 442 FEET MORE OR LESS TO THE RIGHT OF WAY
OF CHICAGO, MILWAUKEE & ST PAUL RAILWAY COMPANY;
THENCE NORTHWESTERLY ALONG SAID RIGHT OF WAY 100
FEET;
THENCE SOUTH PARALLEL WITH AND 93 FEET DISTANCE
FROM EAST BOUNDARY OF TRACT 478 FEET MORE OR LESS
TO A POINT 93 FEET WEST OF THE POINT OF BEGINNING;
THENCE EAST 93 FEET TO THE POINT OF BEGINNING.

EXCEPT THE NORTHERLY 15 FEET FOR TODD ROAD
NORTHEAST.

SITUATE IN THE CITY OF PUYALLUP, COUNTY OF PIERCE,
STATE OF WASHINGTON.

REFERENCES

- ROS 201604295004 (R1)
- ROS 202012225005
- ROS 9005230358
- CHICAGO, MILWAUKEE AND ST PAUL RR NORTH PUYALLUP
TRACK MAPS

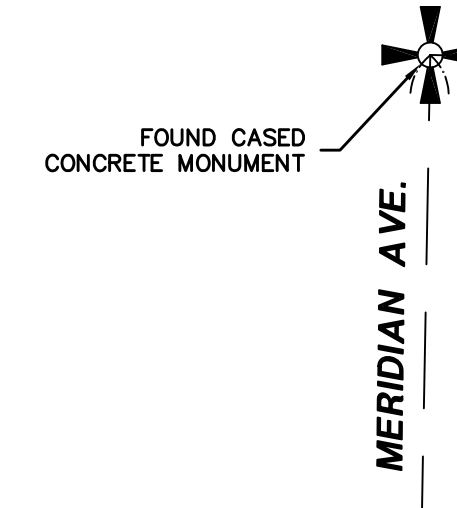

MERIDIAN AVE.

N01°02'07"E 1553.22' (MEASURED) (BASIS OF BEARING)
N01°02'07"E 1287.97' HELD PER RT

590.00'
S88°34'02"E 683.00' HELD PER DEED

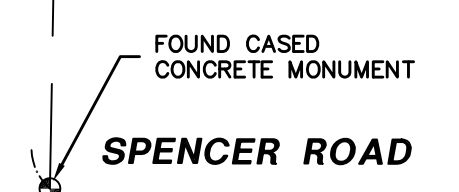

REVISIONS	DESCRIPTION	BY	DATE

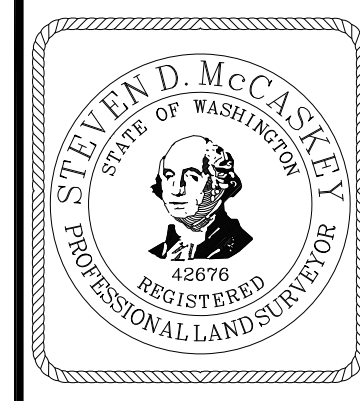

BOUNDARY TOPOGRAPHIC SURVEY
FOR
AMERICAN PRIDE LENDING, LLC

Encompass
ENGINEERING & SURVEYING

Western Washington Division
165 NE Juniper Street, Suite 200
Eastern Washington Division
407 Southwater Blvd. • Clk. Elm, WA 98922 • Phone: (509) 674-7433

JOB NO.	21715
DATE	07/07/22
SCALE	1"=30'
DESIGNED	N/A
DRAWN	LFM
CHECKED	SDM
APPROVED	SDM

ATTACHMENT A

DATA SHEETS

WETLAND DETERMINATION DATA FORM – Western Mountains, Valleys, and Coast Region

Project Site: Parcel: 042022-2008 City/County: Puyallup/ Sampling Date: 6-23-22
 Applicant/Owner: Sekhon State: WA Sampling Point: DP#1
 Investigator(s): John Altmann Section, Township, Range: S22, T20N, R4E
 Landform (hillslope, terrace, etc.): Slope Local relief (concave, convex, none): concave Slope (%):
 Subregion (LRR): A Lat: 47.210042 Long: -122.290862 Datum: NAD83
 Soil Map Unit Name: 31A NWI classification: PFO1C
 Are climatic / hydrologic conditions on the site typical for this time of year? Yes No (If no, explain in Remarks.)
 Are Vegetation , Soil , or Hydrology , significantly disturbed? Are "Normal Circumstances" present? Yes No
 Are Vegetation , Soil , or Hydrology , naturally problematic? (If needed, explain any answers in Remarks.)

SUMMARY OF FINDINGS – Attach site map showing sampling point locations, transects, important features, etc.

Hydrophytic Vegetation Present?	Yes <input type="checkbox"/>	No <input checked="" type="checkbox"/>	Is the Sampled Area within a Wetland?	Yes <input type="checkbox"/>	No <input checked="" type="checkbox"/>
Hydric Soil Present?	Yes <input type="checkbox"/>	No <input checked="" type="checkbox"/>		Yes <input type="checkbox"/>	No <input checked="" type="checkbox"/>
Wetland Hydrology Present?	Yes <input type="checkbox"/>	No <input checked="" type="checkbox"/>		Yes <input type="checkbox"/>	No <input checked="" type="checkbox"/>
Remarks: Upslope of OHW 1-2					

VEGETATION – Use scientific names of plants

Tree Stratum (Plot size: 10')	Absolute % Cover	Dominant Species?	Indicator Status	Dominance Test Worksheet:																
1. <u><i>Alnus rubra</i></u>	<u>90</u>	<u>yes</u>	<u>FAC</u>	Number of Dominant Species That Are OBL, FACW, or FAC: <u>2</u> (A) Total Number of Dominant Species Across All Strata: <u>5</u> (B) Percent of Dominant Species That Are OBL, FACW, or FAC: <u>40</u> (A/B)																
2. <u><i>Pseudotsuga menziesii</i></u>	<u>10</u>	<u>no</u>	<u>FACU</u>																	
3. _____	_____	_____	_____																	
4. _____	_____	_____	_____																	
50% = <u>50</u> , 20% = <u>20</u>	<u>100</u>	= Total Cover																		
<u>Sapling/Shrub Stratum (Plot size: 10')</u>				Prevalence Index worksheet: <table style="width: 100%; border: none;"> <tr> <td style="text-align: center; border: none;">Total % Cover of:</td> <td style="text-align: center; border: none;">Multiply by:</td> </tr> <tr> <td style="border: none;">OBL species _____</td> <td style="border: none;">x1 = _____</td> </tr> <tr> <td style="border: none;">FACW species _____</td> <td style="border: none;">x2 = _____</td> </tr> <tr> <td style="border: none;">FAC species _____</td> <td style="border: none;">x3 = _____</td> </tr> <tr> <td style="border: none;">FACU species _____</td> <td style="border: none;">x4 = _____</td> </tr> <tr> <td style="border: none;">UPL species _____</td> <td style="border: none;">x5 = _____</td> </tr> <tr> <td style="border: none;">Column Totals: _____ (A)</td> <td style="border: none;">_____ (B)</td> </tr> <tr> <td colspan="2" style="border: none; text-align: center;">Prevalence Index = B/A = _____</td> </tr> </table>	Total % Cover of:	Multiply by:	OBL species _____	x1 = _____	FACW species _____	x2 = _____	FAC species _____	x3 = _____	FACU species _____	x4 = _____	UPL species _____	x5 = _____	Column Totals: _____ (A)	_____ (B)	Prevalence Index = B/A = _____	
Total % Cover of:	Multiply by:																			
OBL species _____	x1 = _____																			
FACW species _____	x2 = _____																			
FAC species _____	x3 = _____																			
FACU species _____	x4 = _____																			
UPL species _____	x5 = _____																			
Column Totals: _____ (A)	_____ (B)																			
Prevalence Index = B/A = _____																				
1. <u><i>Ilex aquifolium</i></u>	<u>40</u>	<u>yes</u>	<u>FACU</u>																	
2. <u><i>Oemleria cerasiformis</i></u>	<u>15</u>	<u>yes</u>	<u>FACU</u>																	
3. <u><i>Corylus cornuta</i></u>	<u>10</u>	<u>no</u>	<u>FACU</u>																	
4. <u><i>Rubus armeniacus</i></u>	<u>10</u>	<u>no</u>	<u>FAC</u>																	
5. _____	_____	_____	_____																	
50% = <u>37.5</u> , 20% = <u>15</u>	<u>75</u>	= Total Cover																		
<u>Herb Stratum (Plot size: 10')</u>																				
1. <u><i>Equesetum telmetia</i></u>	<u>30</u>	<u>yes</u>	<u>FACW</u>																	
2. _____	_____	_____	_____																	
3. _____	_____	_____	_____																	
4. _____	_____	_____	_____																	
5. _____	_____	_____	_____																	
6. _____	_____	_____	_____																	
7. _____	_____	_____	_____																	
8. _____	_____	_____	_____																	
9. _____	_____	_____	_____																	
10. _____	_____	_____	_____																	
11. _____	_____	_____	_____																	
50% = <u>15</u> , 20% = <u>6</u>	<u>30</u>	= Total Cover																		
<u>Woody Vine Stratum (Plot size: 10')</u>																				
1. <u><i>Hedera helix</i></u>	<u>100</u>	<u>yes</u>	<u>FACU</u>																	
2. _____	_____	_____	_____																	
50% = <u>50</u> , 20% = <u>20</u>	<u>100</u>	= Total Cover																		
% Bare Ground in Herb Stratum _____																				
Hydrophytic Vegetation Indicators: <input type="checkbox"/> 1 – Rapid Test for Hydrophytic Vegetation <input type="checkbox"/> 2 - Dominance Test is >50% <input type="checkbox"/> 3 - Prevalence Index is ≤3.0 ¹ <input type="checkbox"/> 4 - Morphological Adaptations ¹ (Provide supporting data in Remarks or on a separate sheet) <input type="checkbox"/> 5 - Wetland Non-Vascular Plants ¹ <input type="checkbox"/> Problematic Hydrophytic Vegetation ¹ (Explain) ¹ Indicators of hydric soil and wetland hydrology must be present, unless disturbed or problematic.																				
Hydrophytic Vegetation Present? <table style="width: 100%; border: none;"> <tr> <td style="width: 60%;"></td> <td style="text-align: center;">Yes <input type="checkbox"/></td> <td style="text-align: center;">No <input checked="" type="checkbox"/></td> </tr> </table>					Yes <input type="checkbox"/>	No <input checked="" type="checkbox"/>														
	Yes <input type="checkbox"/>	No <input checked="" type="checkbox"/>																		
Remarks:																				

SOIL

Sampling Point: DP#1

Profile Description: (Describe to the depth needed to document the indicator or confirm the absence of indicators.)

Depth (inches)	Matrix		Redox Features				Texture	Remarks
	Color (moist)	%	Color (moist)	%	Type ¹	Loc ²		
0-15	10 YR 3/3	100	_____	_____	_____	_____	clay loam	_____
_____	_____	_____	_____	_____	_____	_____	_____	_____
_____	_____	_____	_____	_____	_____	_____	_____	_____
_____	_____	_____	_____	_____	_____	_____	_____	_____
_____	_____	_____	_____	_____	_____	_____	_____	_____
_____	_____	_____	_____	_____	_____	_____	_____	_____
_____	_____	_____	_____	_____	_____	_____	_____	_____

¹Type: C= Concentration, D=Depletion, RM=Reduced Matrix, CS=Covered or Coated Sand Grains. ²Location: PL=Pore Lining, M=Matrix

Hydric Soil Indicators: (Applicable to all LRRs, unless otherwise noted.)

- Histosol (A1)
- Histic Epipedon (A2)
- Black Histic (A3)
- Hydrogen Sulfide (A4)
- Depleted Below Dark Surface (A11)
- Thick Dark Surface (A12)
- Sandy Mucky Mineral (S1)
- Sandy Gleyed Matrix (S4)

- Sandy Redox (S5)
- Stripped Matrix (S6)
- Loamy Mucky Mineral (F1) **(except MLRA 1)**
- Loamy Gleyed Matrix (F2)
- Depleted Matrix (F3)
- Redox Dark Surface (F6)
- Depleted Dark Surface (F7)
- Redox Depressions (F8)

Indicators for Problematic Hydric Soils³:

- 2 cm Muck (A10)
- Red Parent Material (TF2)
- Very Shallow Dark Surface (TF12)
- Other (Explain in Remarks)

³Indicators of hydrophytic vegetation and wetland hydrology must be present, unless disturbed or problematic.

Restrictive Layer (if present):

Type: _____
Depth (inches): _____

Hydric Soils Present? Yes No

Remarks:

HYDROLOGY

Wetland Hydrology Indicators:

Primary Indicators (minimum of one required; check all that apply)

- Surface Water (A1)
- High Water Table (A2)
- Saturation (A3)
- Water Marks (B1)
- Sediment Deposits (B2)
- Drift Deposits (B3)
- Algal Mat or Crust (B4)
- Iron Deposits (B5)
- Surface Soil Cracks (B6)
- Inundation Visible on Aerial Imagery (B7)
- Sparsely Vegetated Concave Surface (B8)
- Water-Stained Leaves (B9) **(except MLRA 1, 2, 4A, and 4B)**
- Salt Crust (B11)
- Aquatic Invertebrates (B13)
- Hydrogen Sulfide Odor (C1)
- Oxidized Rhizospheres along Living Roots (C3)
- Presence of Reduced Iron (C4)
- Recent Iron Reduction in Tilled Soils (C6)
- Stunted or Stresses Plants (D1) **(LRR A)**
- Other (Explain in Remarks)

Secondary Indicators (2 or more required)

- Water-Stained Leaves (B9) **(MLRA 1, 2, 4A, and 4B)**
- Drainage Patterns (B10)
- Dry-Season Water Table (C2)
- Saturation Visible on Aerial Imagery (C9)
- Geomorphic Position (D2)
- Shallow Aquitard (D3)
- FAC-Neutral Test (D5)
- Raised Ant Mounds (D6) **(LRR A)**
- Frost-Heave Hummocks (D7)

Field Observations:

Surface Water Present? Yes No Depth (inches): _____
 Water Table Present? Yes No Depth (inches): _____
 Saturation Present? (includes capillary fringe) Yes No Depth (inches): _____

Wetland Hydrology Present? Yes No

Describe Recorded Data (stream gauge, monitoring well, aerial photos, previous inspections), if available:

Remarks: Dry

ATTACHMENT B

WETLAND RATING

RATING SUMMARY – Western Washington

Name of wetland (or ID #): Parcel 0420222008 Date of site visit: 3/1/2022

Rated by Altmann Trained by Ecology? Yes No Date of training 03/08 & 03/15

HGM Class used for rating Riverine & Fresh Water Tidal Wetland has multiple HGM classes? Yes No

NOTE: Form is not complete with out the figures requested (figures can be combined).
 Source of base aerial photo/map Pierce County GIS

OVERALL WETLAND CATEGORY II (based on functions or special characteristics)

1. Category of wetland based on FUNCTIONS

- Category I - Total score = 23 - 27
- X Category II - Total score = 20 - 22
- Category III - Total score = 16 - 19
- Category IV - Total score = 9 - 15

Score for each function based on three ratings
 (order of ratings is not important)

9 = H, H, H
 8 = H, H, M
 7 = H, H, L
 7 = H, M, M
 6 = H, M, L
 6 = M, M, M
 5 = H, L, L
 5 = M, M, L
 4 = M, L, L
 3 = L, L, L

FUNCTION	Improving Water Quality	Hydrologic	Habitat	
<i>List appropriate rating (H, M, L)</i>				
Site Potential	M	M	M	
Landscape Potential	M	H	L	
Value	H	H	H	Total
Score Based on Ratings	7	8	6	21

2. Category based on SPECIAL CHARACTERISTICS of wetland

CHARACTERISTIC	Category
Estuarine	
Wetland of High Conservation Value	
Bog	
Mature Forest	
Old Growth Forest	
Coastal Lagoon	
Interdunal	
None of the above	X

Maps and Figures required to answer questions correctly for Western Washington

Depressional Wetlands

Map of:	To answer questions:	Figure #
Cowardin plant classes	D 1.3, H 1.1, H 1.4	
Hydroperiods	D 1.4, H 1.2	
Location of outlet (<i>can be added to map of hydroperiods</i>)	D 1.1, D 4.1	
Boundary of area within 150 ft of the wetland (<i>can be added to another figure</i>)	D 2.2, D 5.2	
Map of the contributing basin	D 4.3, D 5.3	
1 km Polygon: Area that extends 1 km from entire wetland edge - including polygons for accessible habitat and undisturbed habitat	H 2.1, H 2.2, H 2.3	
Screen capture of map of 303(d) listed waters in basin (from Ecology website)	D 3.1, D 3.2	
Screen capture of list of TMDLs for WRIA in which unit is found (from web)	D 3.3	

Riverine Wetlands

Map of:	To answer questions:	Figure #
Cowardin plant classes	H 1.1, H 1.4	B
Hydroperiods	H 1.2	B
Ponded depressions	R 1.1	B
Boundary of area within 150 ft of the wetland (<i>can be added to another figure</i>)	R 2.4	B
Plant cover of trees, shrubs, and herbaceous plants	R 1.2, R 4.2	B
Width of unit vs. width of stream (<i>can be added to another figure</i>)	R 4.1	B
Map of the contributing basin	R 2.2, R 2.3, R 5.2	E
1 km Polygon: Area that extends 1 km from entire wetland edge - including polygons for accessible habitat and undisturbed habitat	H 2.1, H 2.2, H 2.3	A
Screen capture of map of 303(d) listed waters in basin (from Ecology website)	R 3.1	C
Screen capture of list of TMDLs for WRIA in which unit is found (from web)	R 3.2, R 3.3	D

Lake Fringe Wetlands

Map of:	To answer questions:	Figure #
Cowardin plant classes	L 1.1, L 4.1, H 1.1, H 1.4	
Plant cover of trees, shrubs, and herbaceous plants	L 1.2	
Boundary of area within 150 ft of the wetland (<i>can be added to another figure</i>)	L 2.2	
1 km Polygon: Area that extends 1 km from entire wetland edge - including polygons for accessible habitat and undisturbed habitat	H 2.1, H 2.2, H 2.3	
Screen capture of map of 303(d) listed waters in basin (from Ecology website)	L 3.1, L 3.2	
Screen capture of list of TMDLs for WRIA in which unit is found (from web)	L 3.3	

Slope Wetlands

Map of:	To answer questions:	Figure #
Cowardin plant classes	H 1.1, H 1.4	
Hydroperiods	H 1.2	
Plant cover of dense trees, shrubs, and herbaceous plants	S 1.3	
Plant cover of dense, rigid trees, shrubs, and herbaceous plants (<i>can be added to another figure</i>)	S 4.1	
Boundary of area within 150 ft of the wetland (<i>can be added to another figure</i>)	S 2.1, S 5.1	
1 km Polygon: Area that extends 1 km from entire wetland edge - including polygons for accessible habitat and undisturbed habitat	H 2.1, H 2.2, H 2.3	
Screen capture of map of 303(d) listed waters in basin (from Ecology website)	S 3.1, S 3.2	
Screen capture of list of TMDLs for WRIA in which unit is found (from web)	S 3.3	

RIVERINE AND FRESHWATER TIDAL FRINGE WETLANDS**Water Quality Functions** - Indicators that the site functions to improve water quality

R 1.0. Does the site have the potential to improve water quality?		
R 1.1. Area of surface depressions within the Riverine wetland that can trap sediments during a flooding event:		
Depressions cover $> \frac{3}{4}$ area of wetland	points = 8	2
Depressions cover $> \frac{1}{2}$ area of wetland	points = 4	
Depressions present but cover $< \frac{1}{2}$ area of wetland	points = 2	
No depressions present	points = 0	
R 1.2. Structure of plants in the wetland (areas with $>90\%$ cover at person height, not Cowardin classes)		
Trees or shrubs $> \frac{2}{3}$ area of the wetland	points = 8	8
<input type="checkbox"/> Trees or shrubs $> \frac{1}{3}$ area of the wetland	points = 6	
<input type="checkbox"/> Herbaceous plants (> 6 in high) $> \frac{2}{3}$ area of the wetland	points = 6	
Herbaceous plants (> 6 in high) $> \frac{1}{3}$ area of the wetland	points = 3	
Trees, shrubs, and ungrazed herbaceous $< \frac{1}{3}$ area of the wetland	points = 0	
Total for R 1	Add the points in the boxes above	10

Rating of Site Potential If score is: 12 - 16 = H 6 - 11 = M 0 - 5 = L *Record the rating on the first page*

R 2.0. Does the landscape have the potential to support the water quality function of the site?		
R 2.1. Is the wetland within an incorporated city or within its UGA?	Yes = 2 No = 0	2
R 2.2. Does the contributing basin to the wetland include a UGA or incorporated area?	Yes = 1 No = 0	1
R 2.3. Does at least 10% of the contributing basin contain tilled fields, pastures, or forests that have been clearcut within the last 5 years?	Yes = 1 No = 0	0
R 2.4. Is $> 10\%$ of the area within 150 ft of the wetland in land uses that generate pollutants?	Yes = 1 No = 0	1
R 2.5. Are there other sources of pollutants coming into the wetland that are not listed in questions R 2.1 - R 2.4?		0
Other Sources	Yes = 1 No = 0	
Total for R 2	Add the points in the boxes above	4

Rating of Landscape Potential If score is: 3 - 6 = H 1 or 2 = M 0 = L *Record the rating on the first page*

R 3.0. Is the water quality improvement provided by the site valuable to society?		
R 3.1. Is the wetland along a stream or river that is on the 303(d) list or on a tributary that drains to one within 1 mi?	Yes = 1 No = 0	1
R 3.2. Is the wetland along a stream or river that has TMDL limits for nutrients, toxics, or pathogens?	Yes = 1 No = 0	1
R 3.3. Has the site been identified in a watershed or local plan as important for maintaining water quality? (<i>answer YES if there is a TMDL for the drainage in which the unit is found</i>)	Yes = 2 No = 0	0
Total for R 3	Add the points in the boxes above	2

Rating of Value If score is: 2 - 4 = H 1 = M 0 = L *Record the rating on the first page*

RIVERINE AND FRESHWATER TIDAL FRINGE WETLANDS

Hydrologic Functions - Indicators that site functions to reduce flooding and stream erosion

R 4.0. Does the site have the potential to reduce flooding and erosion?		
R 4.1. Characteristics of the overbank storage the wetland provides: <i>Estimate the average width of the wetland perpendicular to the direction of the flow and the width of the stream or river channel (distance between banks). Calculate the ratio: (average width of wetland)/(average width of stream between banks).</i>		
If the ratio is more than 20	points = 9	2
If the ratio is 10 - 20	points = 6	
If the ratio is 5 - < 10	points = 4	
If the ratio is 1 - < 5	points = 2	
If the ratio is < 1	points = 1	
R 4.2. Characteristics of plants that slow down water velocities during floods: <i>Treat large woody debris as forest or shrub. Choose the points appropriate for the best description (polygons need to have >90% cover at person height. These are NOT Cowardin classes).</i>		7
Forest or shrub for > 1/3 area OR emergent plants > 2/3 area	points = 7	
Forest or shrub for > 1/10 area OR emergent plants > 1/3 area	points = 4	
Plants do not meet above criteria	points = 0	
Total for R 4	Add the points in the boxes above	9



Rating of Site Potential If score is: 12 - 16 = H 6 - 11 = M 0 - 5 = L *Record the rating on the first page*

R 5.0. Does the landscape have the potential to support the hydrologic functions of the site?		
R 5.1. Is the stream or river adjacent to the wetland downcut?	Yes = 0 No = 1	1
R 5.2. Does the up-gradient watershed include a UGA or incorporated area?	Yes = 1 No = 0	1
R 5.3 Is the up-gradient stream or river controlled by dams?	Yes = 0 No = 1	1
Total for R 5	Add the points in the boxes above	3

Rating of Landscape Potential If score is: 3 = H 1 or 2 = M 0 = L *Record the rating on the first page*

R 6.0. Are the hydrologic functions provided by the site valuable to society?		
R 6.1. Distance to the nearest areas downstream that have flooding problems? <i>Choose the description that best fits the site.</i>		
The sub-basin immediately down-gradient of the wetland has flooding problems that result in damage to human or natural resources (e.g., houses or salmon redds)	points = 2	2
Surface flooding problems are in a sub-basin farther down-gradient	points = 1	
No flooding problems anywhere downstream	points = 0	
R 6.2. Has the site been identified as important for flood storage or flood conveyance in a regional flood control plan?	Yes = 2 No = 0	0
Total for R 6	Add the points in the boxes above	2

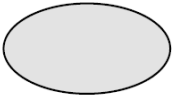
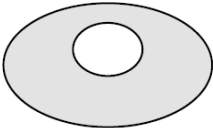
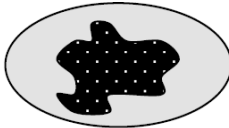
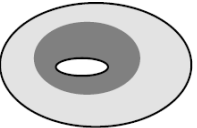
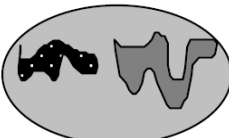
Rating of Value If score is: 2 - 4 = H 1 = M 0 = L *Record the rating on the first page*

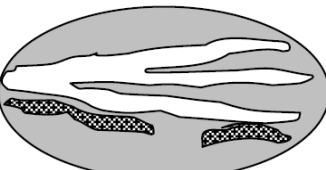
These questions apply to wetlands of all HGM classes.								
HABITAT FUNCTIONS - Indicators that site functions to provide important habitat								
H 1.0. Does the site have the potential to provide habitat?								
<p>H 1.1. Structure of plant community: <i>Indicators are Cowardin classes and strata within the Forested class. Check the Cowardin plant classes in the wetland. Up to 10 patches may be combined for each class to meet the threshold of ¼ ac or more than 10% of the unit if it is smaller than 2.5 ac. Add the number of structures checked.</i></p> <ul style="list-style-type: none"> <input type="checkbox"/> Aquatic bed 4 structures or more: points = 4 <input type="checkbox"/> Emergent 3 structures: points = 2 <input type="checkbox"/> Scrub-shrub (areas where shrubs have > 30% cover) 2 structures: points = 1 <input checked="" type="checkbox"/> Forested (areas where trees have > 30% cover) 1 structure: points = 0 <p><i>If the unit has a Forested class, check if:</i></p> <ul style="list-style-type: none"> <input checked="" type="checkbox"/> The Forested class has 3 out of 5 strata (canopy, sub-canopy, shrubs, herbaceous, moss/ground-cover) that each cover 20% within the Forested polygon 	1							
<p>H 1.2. Hydroperiods Check the types of water regimes (hydroperiods) present within the wetland. The water regime has to cover more than 10% of the wetland or ¼ ac to count (<i>see text for descriptions of hydroperiods</i>).</p> <ul style="list-style-type: none"> <input type="checkbox"/> Permanently flooded or inundated 4 or more types present: points = 3 <input type="checkbox"/> Seasonally flooded or inundated 3 types present: points = 2 <input checked="" type="checkbox"/> Occasionally flooded or inundated 2 types present: points = 1 <input type="checkbox"/> Saturated only 1 types present: points = 0 <input checked="" type="checkbox"/> Permanently flowing stream or river in, or adjacent to, the wetland <input type="checkbox"/> Seasonally flowing stream in, or adjacent to, the wetland <input type="checkbox"/> Lake Fringe wetland 2 points <input type="checkbox"/> Freshwater tidal wetland 2 points 	1							
<p>H 1.3. Richness of plant species Count the number of plant species in the wetland that cover at least 10 ft². <i>Different patches of the same species can be combined to meet the size threshold and you do not have to name the species. Do not include Eurasian milfoil, reed canarygrass, purple loosestrife, Canadian thistle</i></p> <p>If you counted:</p> <table style="width: 100%; border: none;"> <tr> <td style="padding-right: 20px;">> 19 species</td> <td style="text-align: right;">points = 2</td> </tr> <tr> <td>5 - 19 species</td> <td style="text-align: right;">points = 1</td> </tr> <tr> <td>< 5 species</td> <td style="text-align: right;">points = 0</td> </tr> </table>	> 19 species	points = 2	5 - 19 species	points = 1	< 5 species	points = 0	2	
> 19 species	points = 2							
5 - 19 species	points = 1							
< 5 species	points = 0							
<p>H 1.4. Interspersion of habitats Decide from the diagrams below whether interspersion among Cowardin plants classes (described in H 1.1), or the classes and unvegetated areas (can include open water or mudflats) is high, moderate, low, or none. <i>If you have four or more plant classes or three classes and open water, the rating is always high.</i></p> <div style="display: flex; justify-content: space-around; align-items: flex-end; margin-bottom: 20px;"> <div style="text-align: center;">  <p>None = 0 points</p> </div> <div style="text-align: center;">  <p>Low = 1 point</p> </div> <div style="text-align: center;">  <p>Moderate = 2 points</p> </div> <div style="text-align: center;">  </div> </div> <div style="display: flex; justify-content: space-around; align-items: flex-end;"> <div style="text-align: center;">  </div> <div style="text-align: center;">  </div> <div style="text-align: center;">  </div> </div> <p>All three diagrams in this row are HIGH = 3 points</p>	0							

Wetland name or number A

<p>H 1.5. Special habitat features: Check the habitat features that are present in the wetland. <i>The number of checks is the number of points.</i></p> <ul style="list-style-type: none"> <input checked="" type="checkbox"/> Large, downed, woody debris within the wetland (> 4 in diameter and 6 ft long) <input checked="" type="checkbox"/> Standing snags (dbh > 4 in) within the wetland <input checked="" type="checkbox"/> Undercut banks are present for at least 6.6 ft (2 m) and/or overhanging plants extends at least 3.3 ft (1 m) over a stream (or ditch) in, or contiguous with the wetland, for at least 33 ft (10 m) <input type="checkbox"/> Stable steep banks of fine material that might be used by beaver or muskrat for denning (> 30 degree slope) OR signs of recent beaver activity are present (<i>cut shrubs or trees that have not yet weathered where wood is exposed</i>) <input type="checkbox"/> At least ¼ ac of thin-stemmed persistent plants or woody branches are present in areas that are permanently or seasonally inundated (<i>structures for egg-laying by amphibians</i>) <input type="checkbox"/> Invasive plants cover less than 25% of the wetland area in every stratum of plants (see H 1.1 for list of strata) 	3
<p>Total for H 1 Add the points in the boxes above</p>	7

Rating of Site Potential If Score is: 15 - 18 = H 7 - 14 = M 0 - 6 = L *Record the rating on the first page*

<p>H 2.0. Does the landscape have the potential to support the habitat function of the site?</p>	
<p>H 2.1 Accessible habitat (include <i>only habitat that directly abuts wetland unit</i>). Calculate: 0.4 % undisturbed habitat + (_____ 0 % moderate & low intensity land uses / 2) = 0.4%</p> <p>If total accessible habitat is:</p> <ul style="list-style-type: none"> > 1/3 (33.3%) of 1 km Polygon points = 3 20 - 33% of 1 km Polygon points = 2 10 - 19% of 1 km Polygon points = 1 < 10 % of 1 km Polygon points = 0 	0
<p>H 2.2. Undisturbed habitat in 1 km Polygon around the wetland. Calculate: 0 % undisturbed habitat + (_____ 18 % moderate & low intensity land uses / 2) = 9%</p> <p>Undisturbed habitat > 50% of Polygon points = 3</p> <p>Undisturbed habitat 10 - 50% and in 1-3 patches points = 2</p> <p>Undisturbed habitat 10 - 50% and > 3 patches points = 1</p> <p>Undisturbed habitat < 10% of 1 km Polygon points = 0</p>	0
<p>H 2.3 Land use intensity in 1 km Polygon: If</p> <ul style="list-style-type: none"> > 50% of 1 km Polygon is high intensity land use points = (-2) ≤ 50% of 1km Polygon is high intensity points = 0 	-2
<p>Total for H 2 Add the points in the boxes above</p>	-2

Rating of Landscape Potential If Score is: 4 - 6 = H 1 - 3 = M < 1 = L *Record the rating on the first page*







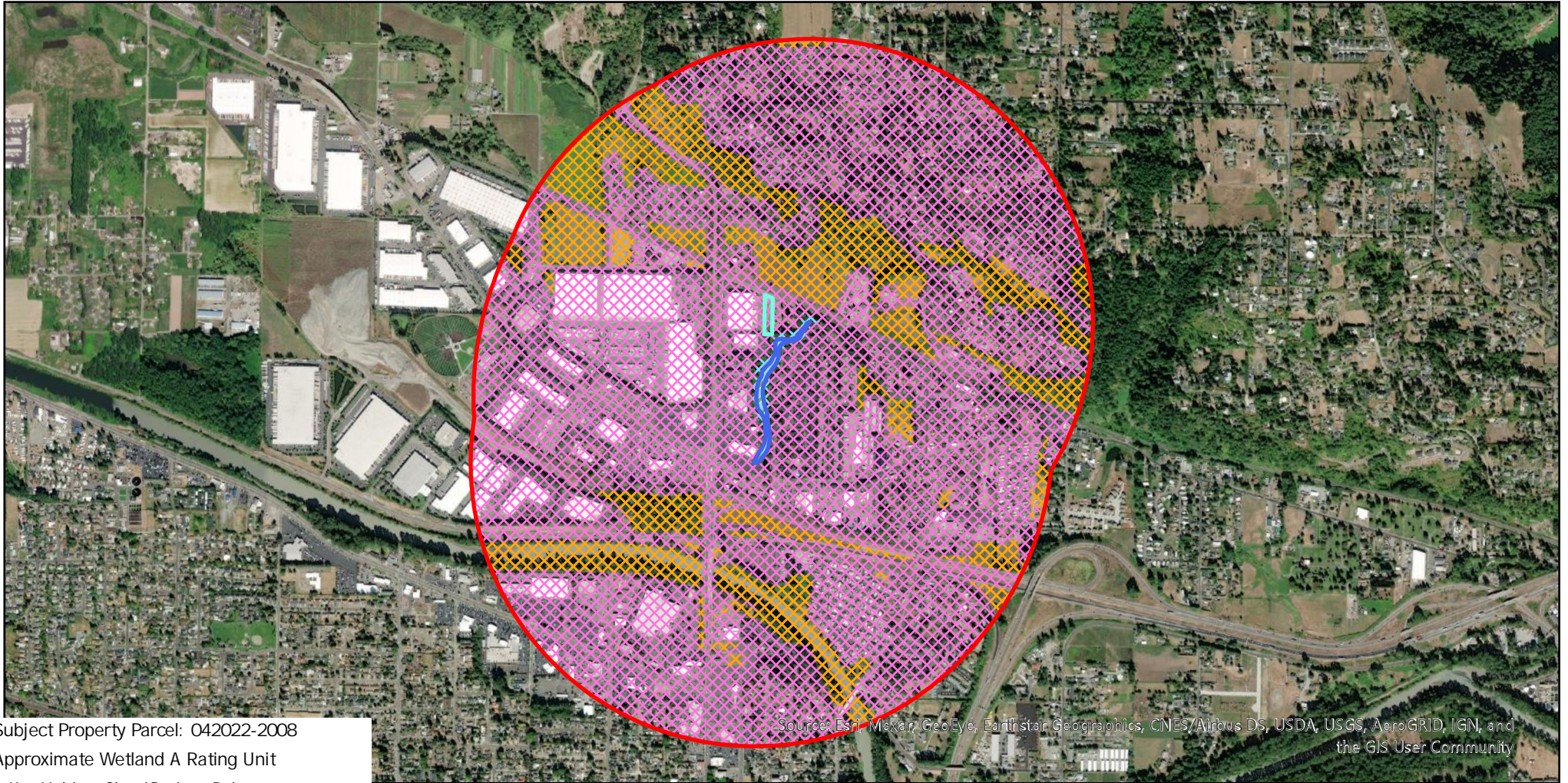

<p>H 3.0. Is the habitat provided by the site valuable to society?</p>	
<p>H 3.1. Does the site provide habitat for species valued in laws, regulations, or policies? <i>Choose only the highest score that applies to the wetland being rated.</i></p> <p>Site meets ANY of the following criteria: points = 2</p> <ul style="list-style-type: none"> <input type="checkbox"/> It has 3 or more priority habitats within 100 m (see next page) <input type="checkbox"/> It provides habitat for Threatened or Endangered species (any plant or animal on the state or federal lists) <input checked="" type="checkbox"/> It is mapped as a location for an individual WDFW priority species <input type="checkbox"/> It is a Wetland of High Conservation Value as determined by the Department of Natural Resources <input type="checkbox"/> It has been categorized as an important habitat site in a local or regional comprehensive plan, in a Shoreline Master Plan, or in a watershed plan <p>Site has 1 or 2 priority habitats (listed on next page) with in 100m points = 1</p> <p>Site does not meet any of the criteria above points = 0</p>	2

Rating of Value If Score is: 2 = H 1 = M 0 = L *Record the rating on the first page*

Figure A

AOA - 6739



-  Subject Property Parcel: 042022-2008
-  Approximate Wetland A Rating Unit
-  1 Km Habitat Classification Polygon
-  Accessible Relatively Undisturbed Habitat 0.4%
-  Accessible Low_Moderate Intensity Habitat 0%
-  Accessible Relatively Undisturbed Habitat 0%
-  Low_Moderate Intensity Habitat 18.0%
-  High Intensity Habitat 81.6%

Source: Esri, Maxar, GeoEye, Earthstar Geographics, CNES/Airbus DS, USDA, USGS, AeroGRID, IGN, and the GIS User Community

0 500 1,000 2,000 3,000 4,000
US Feet



City of Puyallup
Parcel 042022-2008

AOA-6739

Figure B

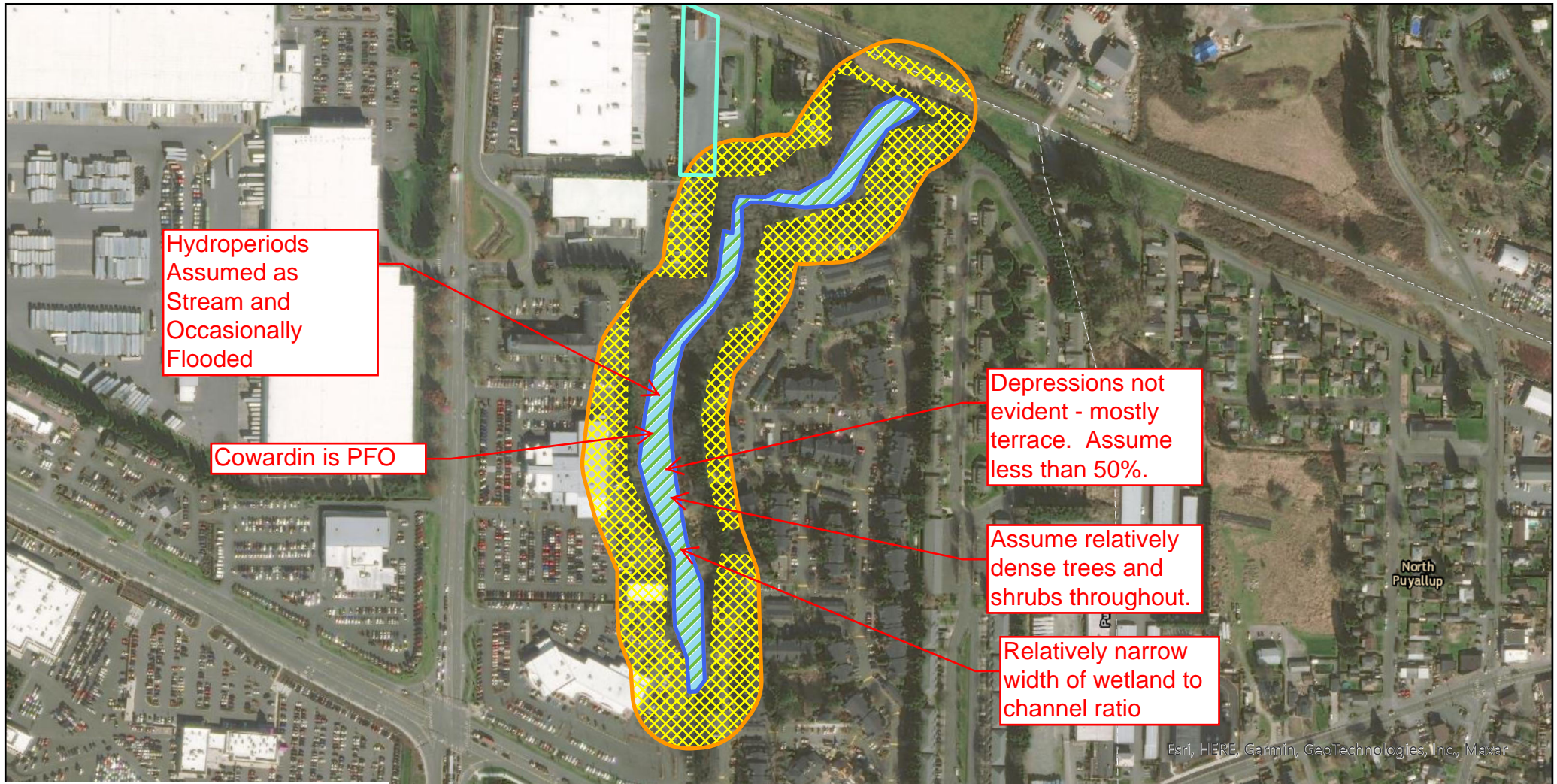

Subject Property Parcel: 042022-2008

Approximate Wetland A

150' Pollution Assessment Polygon

Pollution Generating Surfaces 64.6%

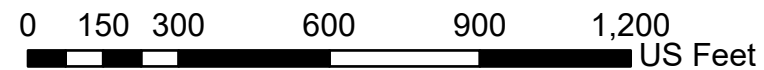

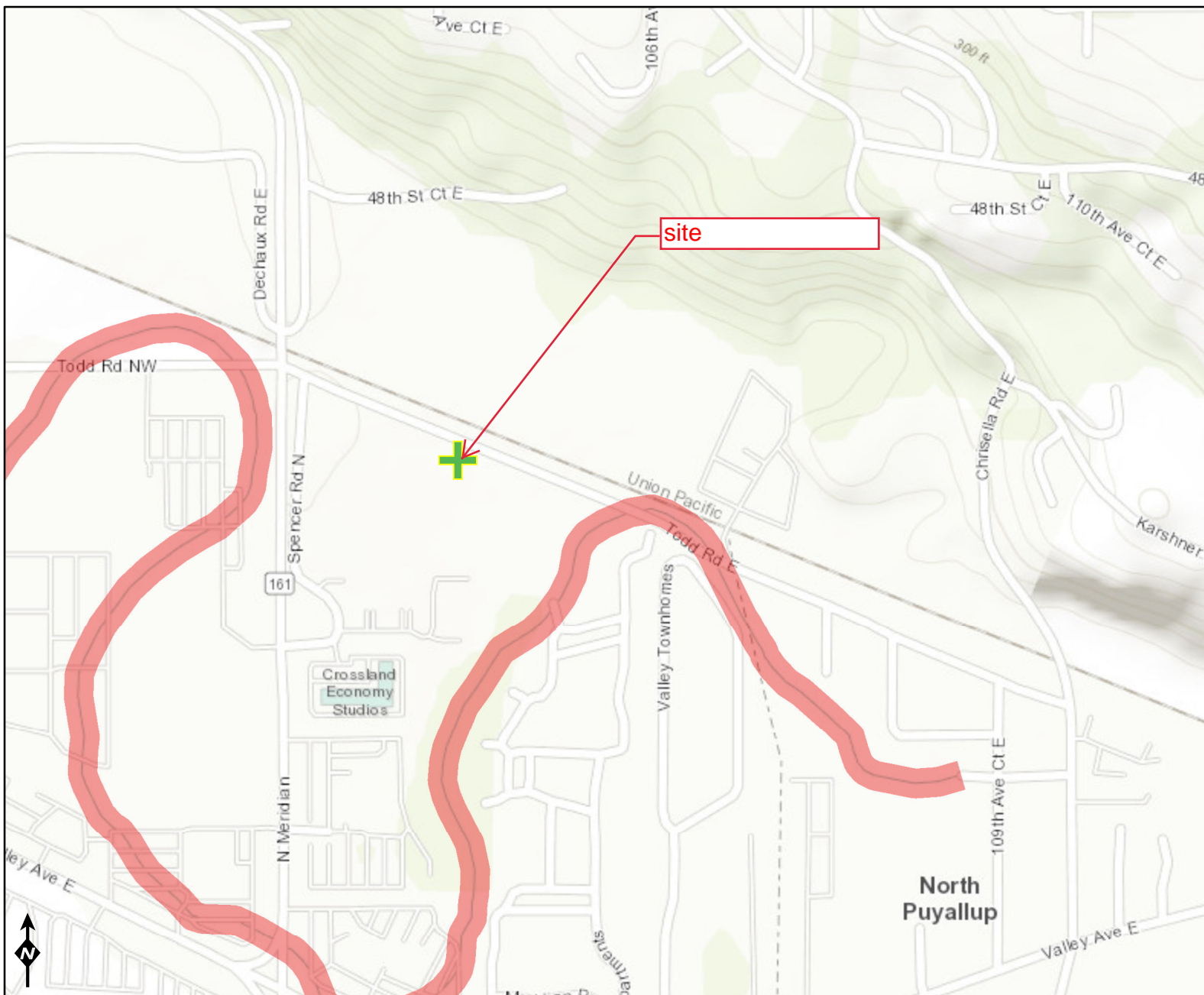

6739 Figure C









Assessed Water/Sediment

Water

-  Category 5 - 303d
-  Category 4C
-  Category 4B
-  Category 4A
-  Category 2
-  Category 1

Sediment

-  Category 5 - 303d
-  Category 4C
-  Category 4B
-  Category 4A
-  Category 2
-  Category 1

Sources: Esri, HERE, Garmin, Intermap, increment P Corp., GEBCO, USGS, FAO, NPS, NRCAN, GeoBase, IGN, Kadaster NL, Ordnance Survey, Esri Japan, METI, Esri China (Hong Kong), (c) OpenStreetMap contributors, and

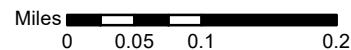

6739 Figure D

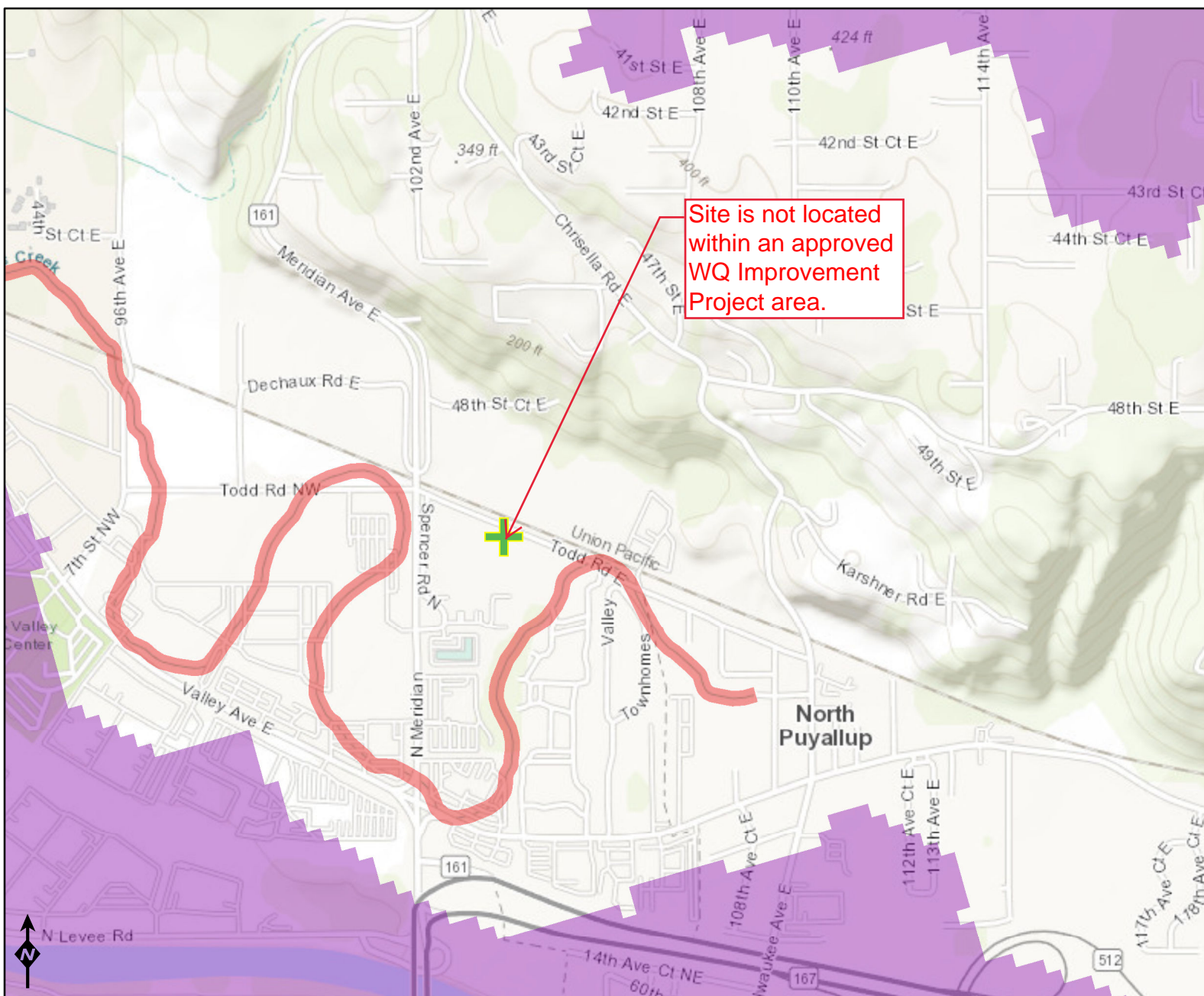

Assessed Water/Sediment

Water

- Category 5 - 303d
- Category 4C
- Category 4B
- Category 4A
- Category 2
- Category 1

Sediment

- Category 5 - 303d
- Category 4C
- Category 4B
- Category 4A
- Category 2
- Category 1

WQ Improvement Projects

- Approved
- In Development

Sources: Esri, HERE, Garmin, Intermap, increment P Corp., GEBCO, USGS, FAO, NPS, NRCAN, GeoBase, IGN, Kadaster NL, Ordnance Survey, Esri Japan, METI, Esri China (Hong Kong), (c) OpenStreetMap contributors, and

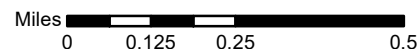
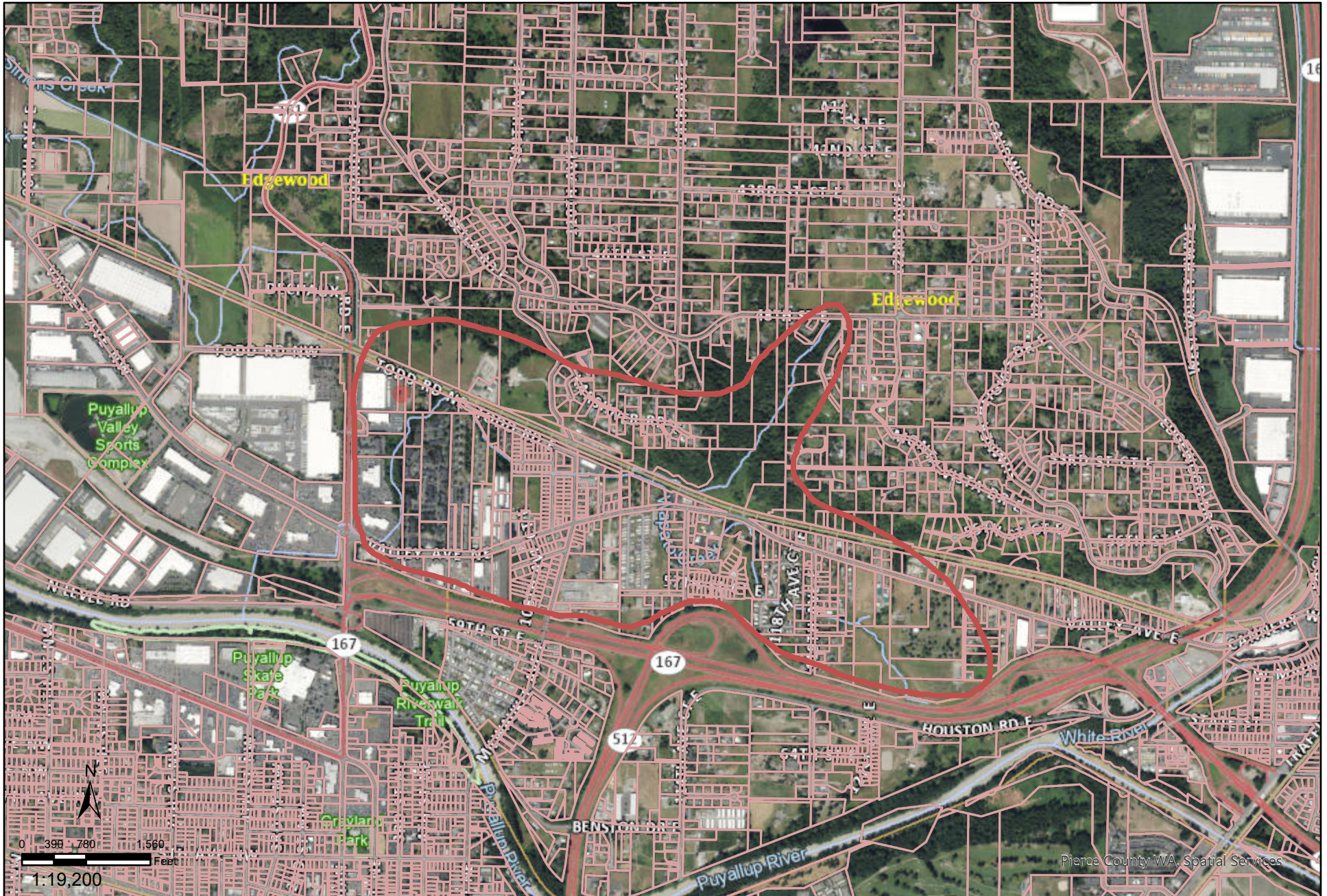

Figure E Rough Basin



Disclaimer: The map features are approximate and have not been surveyed. Additional features not yet mapped may be present. Pierce County assumes no liability for variations ascertained by formal survey.

Date: 3/17/2022 10:44 AM

City of Puyallup
Parcel 042022-2008

AOA-6739

Critical Areas Map

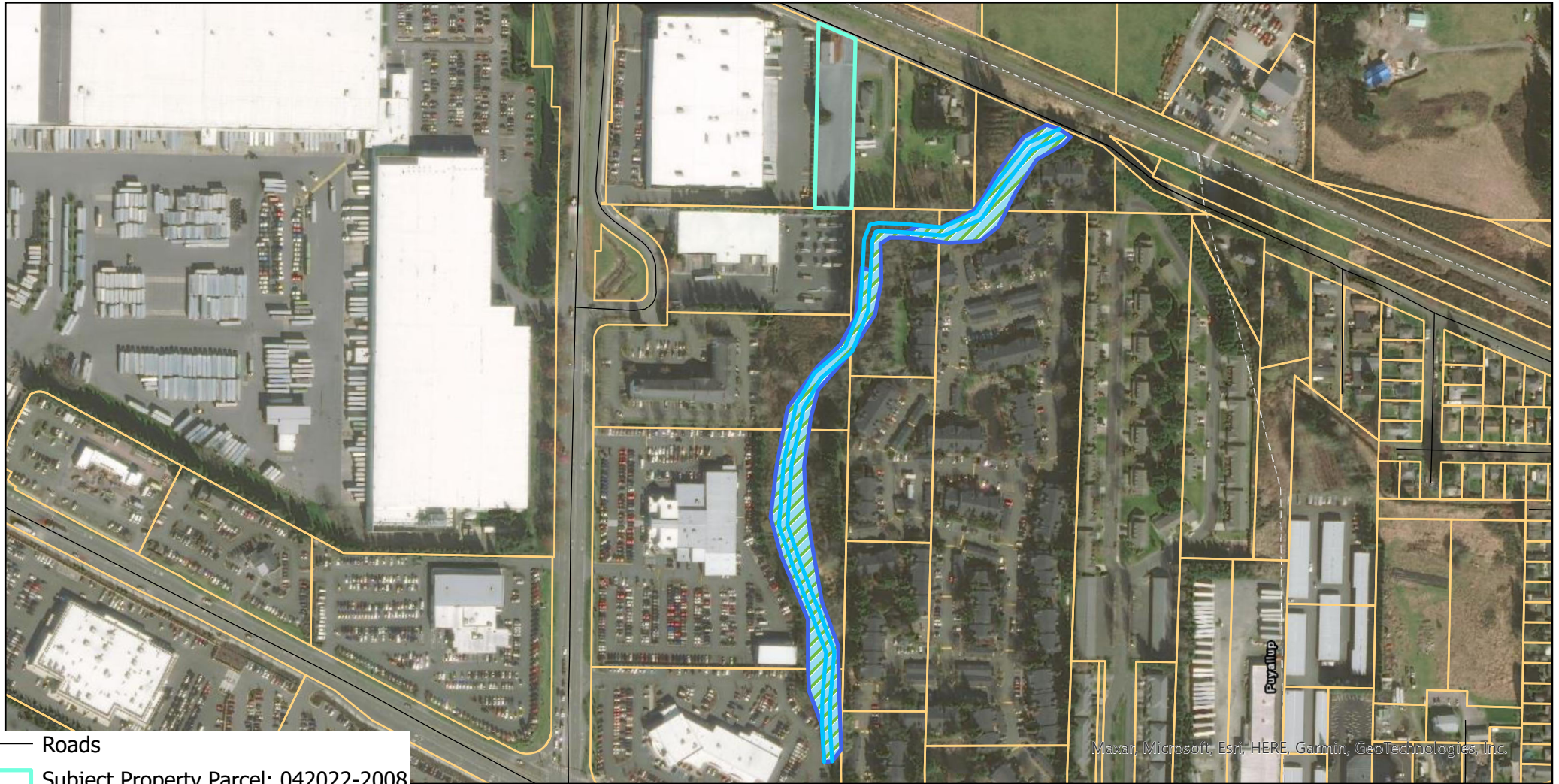

Appendix C

Operation and Maintenance Manual

BMP C101: Preserving Natural Vegetation

Purpose

The purpose of preserving natural vegetation is to reduce erosion wherever practicable. Limiting site disturbance is the single most effective method for reducing erosion. For example, conifers can hold up to about 50 percent of all rain that falls during a storm. Up to 20-30 percent of this rain may never reach the ground but is taken up by the tree or evaporates. Another benefit is that the rain held in the tree can be released slowly to the ground after the storm.

Conditions of Use

Natural vegetation should be preserved on steep slopes, near perennial and intermittent water-courses or swales, and on building sites in wooded areas.

- As required by local governments.
- Phase construction to preserve natural vegetation on the project site for as long as possible during the construction period.

Design and Installation Specifications

Natural vegetation can be preserved in natural clumps or as individual trees, shrubs and vines.

The preservation of individual plants is more difficult because heavy equipment is generally used to remove unwanted vegetation. The points to remember when attempting to save individual plants are:

- Is the plant worth saving? Consider the location, species, size, age, vigor, and the work involved. Local governments may also have ordinances to save natural vegetation and trees.
- Fence or clearly mark areas around trees that are to be saved. It is preferable to keep ground disturbance away from the trees at least as far out as the dripline.

Plants need protection from three kinds of injuries:

- *Construction Equipment* - This injury can be above or below the ground level. Damage results from scarring, cutting of roots, and compaction of the soil. Placing a fenced buffer zone around plants to be saved prior to construction can prevent construction equipment injuries.
- *Grade Changes* - Changing the natural ground level will alter grades, which affects the plant's ability to obtain the necessary air, water, and minerals. Minor fills usually do not cause problems although sensitivity between species does vary and should be checked. Trees can typically tolerate fill of 6 inches or less. For shrubs and other plants, the fill should be less.

When there are major changes in grade, it may become necessary to supply air to the roots of plants. This can be done by placing a layer of gravel and a tile system over the roots before the fill is made. The tile system should be laid out on the original grade leading from a dry well

around the tree trunk. The system should then be covered with small stones to allow air to circulate over the root area.

Lowering the natural ground level can seriously damage trees and shrubs. The highest percentage of the plant roots are in the upper 12 inches of the soil and cuts of only 2-3 inches can cause serious injury. To protect the roots it may be necessary to terrace the immediate area around the plants to be saved. If roots are exposed, construction of retaining walls may be needed to keep the soil in place. Plants can also be preserved by leaving them on an undisturbed, gently sloping mound. To increase the chances for survival, it is best to limit grade changes and other soil disturbances to areas outside the dripline of the plant.

- *Excavations* - Protect trees and other plants when excavating for drainfields, power, water, and sewer lines. Where possible, the trenches should be routed around trees and large shrubs. When this is not possible, it is best to tunnel under them. This can be done with hand tools or with power augers. If it is not possible to route the trench around plants to be saved, then the following should be observed:
 - Cut as few roots as possible. When you have to cut, cut clean. Paint cut root ends with a wood dressing like asphalt base paint if roots will be exposed for more than 24-hours.
 - Backfill the trench as soon as possible.
 - Tunnel beneath root systems as close to the center of the main trunk to preserve most of the important feeder roots.

Some problems that can be encountered with a few specific trees are:

- Maple, Dogwood, Red alder, Western hemlock, Western red cedar, and Douglas fir do not readily adjust to changes in environment and special care should be taken to protect these trees.
- The windthrow hazard of Pacific silver fir and madrona is high, while that of Western hemlock is moderate. The danger of windthrow increases where dense stands have been thinned. Other species (unless they are on shallow, wet soils less than 20 inches deep) have a low windthrow hazard.
- Cottonwoods, maples, and willows have water-seeking roots. These can cause trouble in sewer lines and infiltration fields. On the other hand, they thrive in high moisture conditions that other trees would not.
- Thinning operations in pure or mixed stands of Grand fir, Pacific silver fir, Noble fir, Sitka spruce, Western red cedar, Western hemlock, Pacific dogwood, and Red alder can cause serious disease problems. Disease can become established through damaged limbs, trunks, roots, and freshly cut stumps. Diseased and weakened trees are also susceptible to insect attack.

Maintenance Standards

Inspect flagged and/or fenced areas regularly to make sure flagging or fencing has not been removed or damaged. If the flagging or fencing has been damaged or visibility reduced, it shall be repaired or replaced immediately and visibility restored.

If tree roots have been exposed or injured, “prune” cleanly with an appropriate pruning saw or loppers directly above the damaged roots and recover with native soils. Treatment of sap flowing trees (fir, hemlock, pine, soft maples) is not advised as sap forms a natural healing barrier.

BMP C102: Buffer Zones

Purpose

Creation of an undisturbed area or strip of natural vegetation or an established suitable planting that will provide a living filter to reduce soil erosion and stormwater runoff velocities.

Conditions of Use

Buffer zones are used along streams, wetlands and other bodies of water that need protection from erosion and sedimentation. Contractors can use vegetative buffer zone BMPs to protect natural swales and they can incorporate them into the natural landscaping of an area.

Do not use critical-areas buffer zones as sediment treatment areas. These areas shall remain completely undisturbed. The local permitting authority may expand the buffer widths temporarily to allow the use of the expanded area for removal of sediment.

The types of buffer zones can change the level of protection required as shown below:

Designated Critical Area Buffers - buffers that protect Critical Areas, as defined by the Washington State Growth Management Act, and are established and managed by the local permitting authority. These should not be disturbed and must be protected with sediment control BMPs to prevent impacts. The local permitting authority may expand the buffer widths temporarily to allow the use of the expanded area for removal of sediment.

Vegetative Buffer Zones - areas that may be identified in undisturbed vegetation areas or managed vegetation areas that are outside any Designated Critical Area Buffer. They may be utilized to provide an additional sediment control area and/or reduce runoff velocities. If being used for preservation of natural vegetation, they should be arranged in clumps or strips. They can be used to protect natural swales and incorporated into the natural landscaping area.

Design and Installation Specifications

- Preserving natural vegetation or plantings in clumps, blocks, or strips is generally the easiest and most successful method.
- Leave all unstable steep slopes in natural vegetation.
- Mark clearing limits and keep all equipment and construction debris out of the natural areas and buffer zones. Steel construction fencing is the most effective method to protect sensitive areas and buffers. Alternatively, wire-backed silt fence on steel posts is marginally effective. Flagging alone is typically not effective.
- Keep all excavations outside the dripline of trees and shrubs.
- Do not push debris or extra soil into the buffer zone area because it will cause damage by

burying and smothering vegetation.

- Vegetative buffer zones for streams, lakes or other waterways shall be established by the local permitting authority or other state or federal permits or approvals.

Maintenance Standards

Inspect the area frequently to make sure flagging remains in place and the area remains undisturbed. Replace all damaged flagging immediately. Remove all materials located in the buffer area that may impede the ability of the vegetation to act as a filter.

BMP C105: Stabilized Construction Access

Purpose

Stabilized construction accesses are established to reduce the amount of sediment transported onto paved roads outside the project site by vehicles or equipment. This is done by constructing a stabilized pad of quarry spalls at entrances and exits for project sites.

Conditions of Use

Construction accesses shall be stabilized wherever traffic will be entering or leaving a construction site if paved roads or other paved areas are within 1,000 feet of the site.

For residential subdivision construction sites, provide a stabilized construction access for each residence, rather than only at the main subdivision entrance. Stabilized surfaces shall be of sufficient length/width to provide vehicle access/parking, based on lot size and configuration.

On large commercial, highway, and road projects, the designer should include enough extra materials in the contract to allow for additional stabilized accesses not shown in the initial Construction SWPPP. It is difficult to determine exactly where access to these projects will take place; additional materials will enable the contractor to install them where needed.

Design and Installation Specifications

See [Figure II-3.1: Stabilized Construction Access](#) for details. Note: the 100' minimum length of the access shall be reduced to the maximum practicable size when the size or configuration of the site does not allow the full length (100').

Construct stabilized construction accesses with a 12-inch thick pad of 4-inch to 8-inch quarry spalls, a 4-inch course of asphalt treated base (ATB), or use existing pavement. Do not use crushed concrete, cement, or calcium chloride for construction access stabilization because these products raise pH levels in stormwater and concrete discharge to waters of the State is prohibited.

A separation geotextile shall be placed under the spalls to prevent fine sediment from pumping up into the rock pad. The geotextile shall meet the standards listed in [Table II-3.2: Stabilized Construction Access Geotextile Standards](#).

Table II-3.2: Stabilized Construction Access Geotextile Standards

Geotextile Property	Required Value
Grab Tensile Strength (ASTM D4751)	200 psi min.

**Table II-3.2: Stabilized Construction Access
Geotextile Standards (continued)**

Geotextile Property	Required Value
Grab Tensile Elongation (ASTM D4632)	30% max.
Mullen Burst Strength (ASTM D3786-80a)	400 psi min.
AOS (ASTM D4751)	20-45 (U.S. standard sieve size)

- Consider early installation of the first lift of asphalt in areas that will be paved; this can be used as a stabilized access. Also consider the installation of excess concrete as a stabilized access. During large concrete pours, excess concrete is often available for this purpose.
- Fencing (see [BMP C 103: High-Visibility Fence](#)) shall be installed as necessary to restrict traffic to the construction access.
- Whenever possible, the access shall be constructed on a firm, compacted subgrade. This can substantially increase the effectiveness of the pad and reduce the need for maintenance.
- Construction accesses should avoid crossing existing sidewalks and back of walk drains if at all possible. If a construction access must cross a sidewalk or back of walk drain, the full length of the sidewalk and back of walk drain must be covered and protected from sediment leaving the site.

Alternative Material Specification

WSDOT has raised safety concerns about the Quarry Spall rock specified above. WSDOT observes that the 4-inch to 8-inch rock sizes can become trapped between Dually truck tires, and then released off-site at highway speeds. WSDOT has chosen to use a modified specification for the rock while continuously verifying that the Stabilized Construction Access remains effective. To remain effective, the BMP must prevent sediment from migrating off site. To date, there has been no performance testing to verify operation of this new specification. Jurisdictions may use the alternative specification, but must perform increased off-site inspection if they use, or allow others to use, it.

Stabilized Construction Accesses may use material that meets the requirements of WSDOT's *Standard Specifications for Road, Bridge, and Municipal Construction* Section 9-03.9(1) ([WSDOT, 2016](#)) for ballast except for the following special requirements.

The grading and quality requirements are listed in [Table II-3.3: Stabilized Construction Access Alternative Material Requirements](#).

**Table II-3.3: Stabilized
Construction Access
Alternative Material
Requirements**

Sieve Size	Percent Passing
2½"	99-100

**Table II-3.3: Stabilized
Construction Access
Alternative Material
Requirements
(continued)**

Sieve Size	Percent Passing
2"	65-100
¾"	40-80
No. 4	5 max.
No. 100	0-2
% Fracture	75 min.

- All percentages are by weight.
- The sand equivalent value and dust ratio requirements do not apply.
- The fracture requirement shall be at least one fractured face and will apply the combined aggregate retained on the No. 4 sieve in accordance with FOP for AASHTO T 335.

Maintenance Standards

Quarry spalls shall be added if the pad is no longer in accordance with the specifications.

- If the access is not preventing sediment from being tracked onto pavement, then alternative measures to keep the streets free of sediment shall be used. This may include replacement/cleaning of the existing quarry spalls, street sweeping, an increase in the dimensions of the access, or the installation of [BMP C106: Wheel Wash](#).
- Any sediment that is tracked onto pavement shall be removed by shoveling or street sweeping. The sediment collected by sweeping shall be removed or stabilized on site. The pavement shall not be cleaned by washing down the street, except when high efficiency sweeping is ineffective and there is a threat to public safety. If it is necessary to wash the streets, the construction of a small sump to contain the wash water shall be considered. The sediment would then be washed into the sump where it can be controlled.
- Perform street sweeping by hand or with a high efficiency sweeper. Do not use a non-high efficiency mechanical sweeper because this creates dust and throws soils into storm systems or conveyance ditches.
- Any quarry spalls that are loosened from the pad, which end up on the roadway shall be removed immediately.
- If vehicles are entering or exiting the site at points other than the construction access(es), [BMP C103: High-Visibility Fence](#) shall be installed to control traffic.

- Upon project completion and site stabilization, all construction accesses intended as permanent access for maintenance shall be permanently stabilized.

Figure II-3.1: Stabilized Construction Access

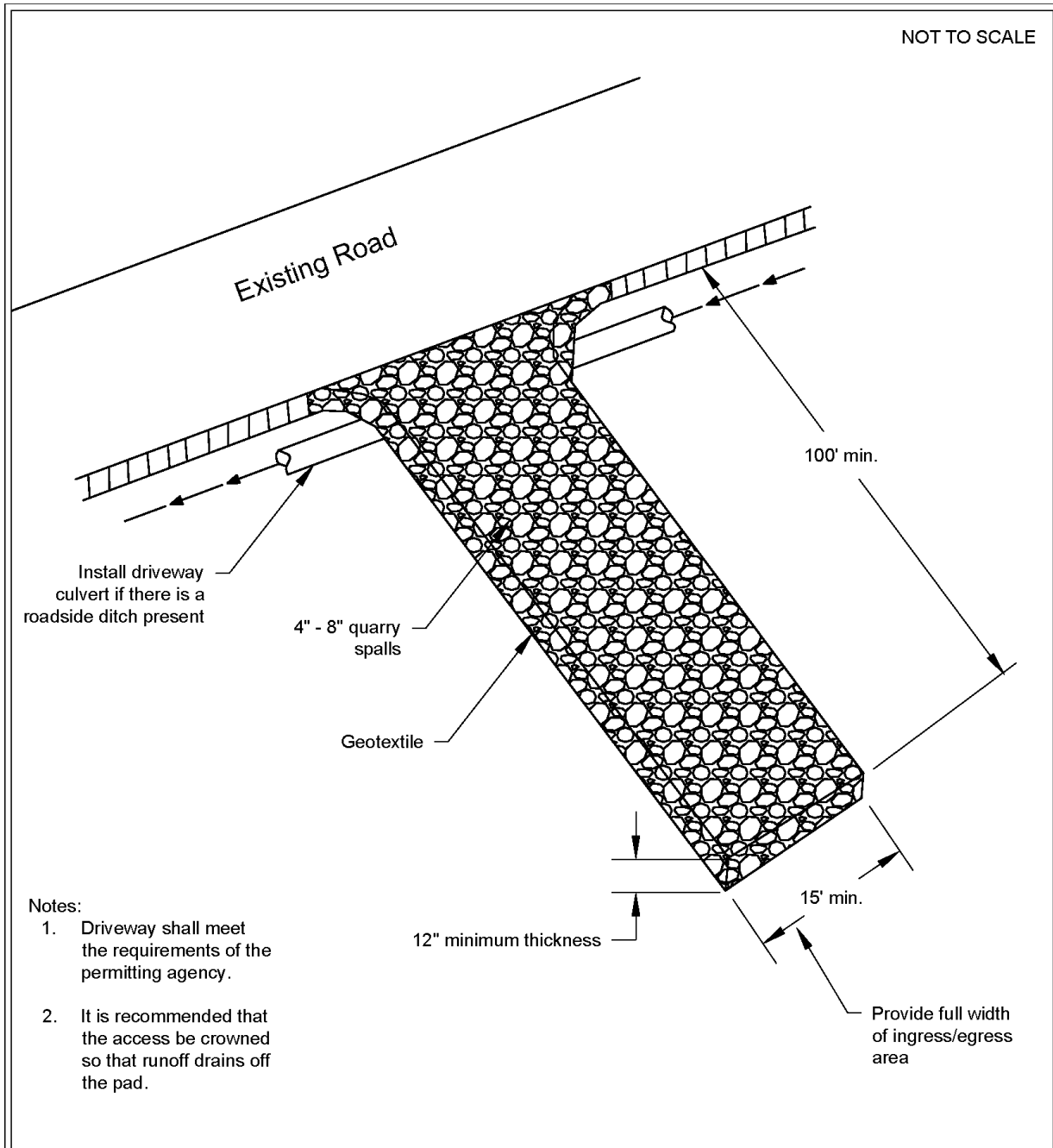

Stabilized Construction Access

Revised June 2018

Please see <http://www.ecy.wa.gov/copyright.html> for copyright notice including permissions, limitation of liability, and disclaimer.

Approved as Functionally Equivalent

Ecology has approved products as able to meet the requirements of this BMP. The products did not pass through the Technology Assessment Protocol – Ecology (TAPE) process. Local jurisdictions may choose not to accept these products, or may require additional testing prior to consideration for local use. Products that Ecology has approved as functionally equivalent are available for review on Ecology’s website at:

<https://ecology.wa.gov/Regulations-Permits/Guidance-technical-assistance/Stormwater-permittee-guidance-resources/Emerging-stormwater-treatment-technologies>

BMP C106: Wheel Wash

Purpose

Wheel washes reduce the amount of sediment transported onto paved roads by washing dirt from the wheels of motor vehicles prior to the motor vehicles leaving the construction site.

Conditions of Use

- Use a wheel wash when [BMP C 105: Stabilized Construction Access](#) is not preventing sediment from being tracked off site.
- Wheel washing is generally an effective BMP when installed with careful attention to topography. For example, a wheel wash can be detrimental if installed at the top of a slope abutting a right-of-way where the water from the dripping truck can run unimpeded into the street.
- Pressure washing combined with an adequately sized and surfaced pad with direct drainage to a large 10-foot x 10-foot sump can be very effective.
- Wheel wash wastewater is not stormwater. It is commonly called process water, and must be discharged to a separate on-site treatment system that prevents discharge to waters of the State, or to the sanitary sewer with local sewer district approval.
- Wheel washes may use closed-loop recirculation systems to conserve water use.
- Wheel wash wastewater shall not include wastewater from concrete washout areas.
- When practical, the wheel wash should be placed in sequence with [BMP C 105: Stabilized Construction Access](#). Locate the wheel wash such that vehicles exiting the wheel wash will enter directly onto [BMP C 105: Stabilized Construction Access](#). In order to achieve this, [BMP C 105: Stabilized Construction Access](#) may need to be extended beyond the standard installation to meet the exit of the wheel wash.

Design and Installation Specifications

Suggested details are shown in [Figure II-3.2: Wheel Wash](#). The Local Permitting Authority may allow other designs. A minimum of 6 inches of asphalt treated base (ATB) over crushed base material or 8 inches over a good subgrade is recommended to pave the wheel wash.

Use a low clearance truck to test the wheel wash before paving. Either a belly dump or lowboy will work well to test clearance.

Keep the water level from 12 to 14 inches deep to avoid damage to truck hubs and filling the truck tongues with water.

Midpoint spray nozzles are only needed in extremely muddy conditions.

Wheel wash systems should be designed with a small grade change, 6- to 12-inches for a 10-foot-wide pond, to allow sediment to flow to the low side of pond to help prevent re-suspension of sediment. A drainpipe with a 2- to 3-foot riser should be installed on the low side of the pond to allow for easy cleaning and refilling. Polymers may be used to promote coagulation and flocculation in a closed-loop system. Polyacrylamide (PAM) added to the wheel wash water at a rate of 0.25 - 0.5 pounds per 1,000 gallons of water increases effectiveness and reduces cleanup time. If PAM is already being used for dust or erosion control and is being applied by a water truck, the same truck can be used to change the wash water.

Maintenance Standards

The wheel wash should start out each day with fresh water.

The wheel wash water should be changed a minimum of once per day. On large earthwork jobs where more than 10-20 trucks per hour are expected, the wheel wash water will need to be changed more often.

Approved as Functionally Equivalent

Ecology has approved products as able to meet the requirements of this BMP. The products did not pass through the Technology Assessment Protocol – Ecology (TAPE) process. Local jurisdictions may choose not to accept these products, or may require additional testing prior to consideration for local use. Products that Ecology has approved as functionally equivalent are available for review on Ecology's website at:

<https://ecology.wa.gov/Regulations-Permits/Guidance-technical-assistance/Stormwater-permittee-guidance-resources/Emerging-stormwater-treatment-technologies>

Figure II-3.2: Wheel Wash

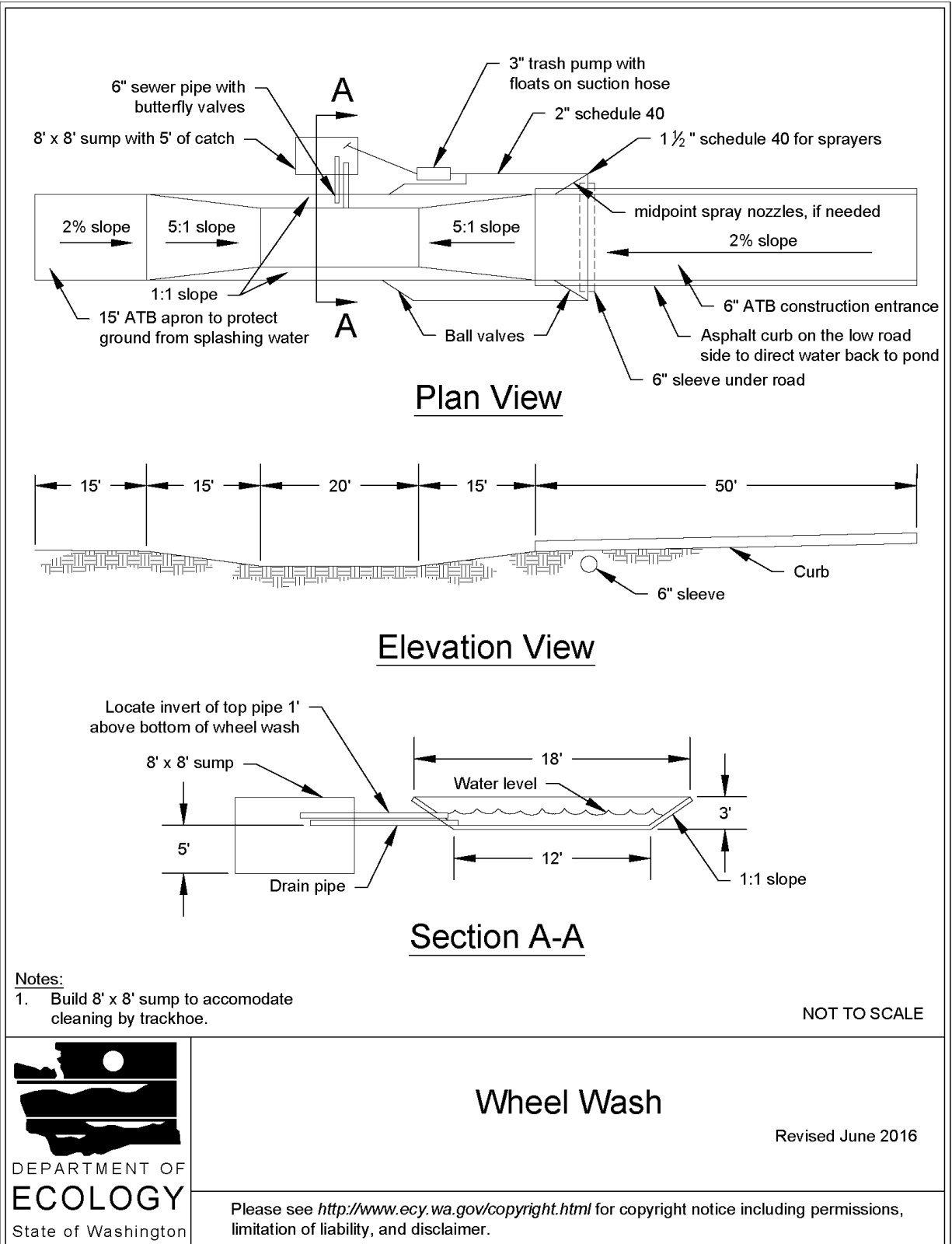

Crushed rock, gravel base, etc., shall be added as required to maintain a stable driving surface and to stabilize any areas that have eroded.

Following construction, these areas shall be restored to pre-construction condition or better to prevent future erosion.

Perform street cleaning at the end of each day or more often if necessary.

BMP C120: Temporary and Permanent Seeding

Purpose

Seeding reduces erosion by stabilizing exposed soils. A well-established vegetative cover is one of the most effective methods of reducing erosion.

Conditions of Use

Use seeding throughout the project on disturbed areas that have reached final grade or that will remain unworked for more than 30 days.

The optimum seeding windows for western Washington are April 1 through June 30 and September 1 through October 1.

Between July 1 and August 30 seeding requires irrigation until 75 percent grass cover is established.

Between October 1 and March 30 seeding requires a cover of mulch or an erosion control blanket until 75 percent grass cover is established.

Review all disturbed areas in late August to early September and complete all seeding by the end of September. Otherwise, vegetation will not establish itself enough to provide more than average protection.

Mulch is required at all times for seeding because it protects seeds from heat, moisture loss, and transport due to runoff. Mulch can be applied on top of the seed or simultaneously by hydroseeding. See [BMP C121: Mulching](#) for specifications.

Seed and mulch all disturbed areas not otherwise vegetated at final site stabilization. Final stabilization means the completion of all soil disturbing activities at the site and the establishment of a permanent vegetative cover, or equivalent permanent stabilization measures (such as pavement, riprap, gabions, or geotextiles) which will prevent erosion. See [BMP T5.13: Post-Construction Soil Quality and Depth](#).

Design and Installation Specifications

General

- Install channels intended for vegetation before starting major earthwork and hydroseed with a Bonded Fiber Matrix. For vegetated channels that will have high flows, install erosion control blankets over the top of hydroseed. Before allowing water to flow in vegetated channels, establish 75 percent vegetation cover. If vegetated channels cannot be established by seed

before water flow; install sod in the channel bottom — over top of hydromulch and erosion control blankets.

- Confirm the installation of all required surface water control measures to prevent seed from washing away.
- Hydroseed applications shall include a minimum of 1,500 pounds per acre of mulch with 3 percent tackifier. See [BMP C121: Mulching](#) for specifications.
- Areas that will have seeding only and not landscaping may need compost or meal-based mulch included in the hydroseed in order to establish vegetation. Re-install native topsoil on the disturbed soil surface before application. See [BMP T5.13: Post-Construction Soil Quality and Depth](#).
- When installing seed via hydroseeding operations, only about 1/3 of the seed actually ends up in contact with the soil surface. This reduces the ability to establish a good stand of grass quickly. To overcome this, consider increasing seed quantities by up to 50 percent.
- Enhance vegetation establishment by dividing the hydromulch operation into two phases:
 - Phase 1- Install all seed and fertilizer with 25-30 percent mulch and tackifier onto soil in the first lift.
 - Phase 2- Install the rest of the mulch and tackifier over the first lift.

Or, enhance vegetation by:

- Installing the mulch, seed, fertilizer, and tackifier in one lift.
- Spread or blow straw over the top of the hydromulch at a rate of 800-1000 pounds per acre.
- Hold straw in place with a standard tackifier.

Both of these approaches will increase cost moderately but will greatly improve and enhance vegetative establishment. The increased cost may be offset by the reduced need for:

- Irrigation.
- Reapplication of mulch.
- Repair of failed slope surfaces.

This technique works with standard hydromulch (1,500 pounds per acre minimum) and Bonded Fiber Matrix/ Mechanically Bonded Fiber Matrix (BFM/MBFMs) (3,000 pounds per acre minimum).

- Seed may be installed by hand if:
 - Temporary and covered by straw, mulch, or topsoil.
 - Permanent in small areas (usually less than 1 acre) and covered with mulch, topsoil, or erosion blankets.
- The seed mixes listed in [Table II-3.4: Temporary and Permanent Seed Mixes](#) include

recommended mixes for both temporary and permanent seeding.

- Apply these mixes, with the exception of the wet area seed mix, at a rate of 120 pounds per acre. This rate can be reduced if soil amendments or slow-release fertilizers are used. Apply the wet area seed mix at a rate of 60 pounds per acre.
- Consult the local suppliers or the local conservation district for their recommendations. The appropriate mix depends on a variety of factors, including location, exposure, soil type, slope, and expected foot traffic. Alternative seed mixes approved by the local authority may be used, depending on the soil type and hydrology of the area.

Table II-3.4: Temporary and Permanent Seed Mixes

Common Name	Latin Name	% Weight	% Purity	% Germination
Temporary Erosion Control Seed Mix				
A standard mix for areas requiring a temporary vegetative cover.				
Chewings or annual blue grass	<i>Festuca rubra var. commutata</i> or <i>Poa anna</i>	40	98	90
Perennial rye	<i>Lolium perenne</i>	50	98	90
Redtop or colonial bentgrass	<i>Agrostis alba</i> or <i>Agrostis tenuis</i>	5	92	85
White dutch clover	<i>Trifolium repens</i>	5	98	90
Landscaping Seed Mix				
A recommended mix for landscaping seed.				
Perennial rye blend	<i>Lolium perenne</i>	70	98	90
Chewings and red fescue blend	<i>Festuca rubra var. commutata</i> or <i>Festuca rubra</i>	30	98	90
Low-Growing Turf Seed Mix				
A turf seed mix for dry situations where there is no need for watering. This mix requires very little maintenance.				
Dwarf tall fescue (several varieties)	<i>Festuca arundinacea var.</i>	45	98	90
Dwarf perennial rye (Barclay)	<i>Lolium perenne var. barclay</i>	30	98	90
Red fescue	<i>Festuca rubra</i>	20	98	90
Colonial bentgrass	<i>Agrostis tenuis</i>	5	98	90
Bioswale Seed Mix				
A seed mix for bioswales and other intermittently wet areas.				
Tall or meadow fes-	<i>Festuca arundin-</i>	75-80	98	90

Table II-3.4: Temporary and Permanent Seed Mixes (continued)

Common Name	Latin Name	% Weight	% Purity	% Germination
cue	<i>acea</i> or <i>Festuca elatior</i>			
Seaside/Creeping bentgrass	<i>Agrostis palustris</i>	10-15	92	85
Redtop bentgrass	<i>Agrostis alba</i> or <i>Agrostis gigantea</i>	5-10	90	80
Wet Area Seed Mix				
A low-growing, relatively non-invasive seed mix appropriate for very wet areas that are not regulated wetlands. Consult Hydraulic Permit Authority (HPA) for seed mixes if applicable.				
Tall or meadow fescue	<i>Festuca arundinacea</i> or <i>Festuca elatior</i>	60-70	98	90
Seaside/Creeping bentgrass	<i>Agrostis palustris</i>	10-15	98	85
Meadow foxtail	<i>Alepocurus pratensis</i>	10-15	90	80
Alsike clover	<i>Trifolium hybridum</i>	1-6	98	90
Redtop bentgrass	<i>Agrostis alba</i>	1-6	92	85
Meadow Seed Mix				
A recommended meadow seed mix for infrequently maintained areas or non-maintained areas where colonization by native plants is desirable. Likely applications include rural road and utility right-of-way. Seeding should take place in September or very early October in order to obtain adequate establishment prior to the winter months. Consider the appropriateness of clover, a fairly invasive species, in the mix. Amending the soil can reduce the need for clover.				
Redtop or Oregon bentgrass	<i>Agrostis alba</i> or <i>Agrostis oregonensis</i>	20	92	85
Red fescue	<i>Festuca rubra</i>	70	98	90
White dutch clover	<i>Trifolium repens</i>	10	98	90

Roughening and Rototilling

- The seedbed should be firm and rough. Roughen all soil no matter what the slope. Track walk slopes before seeding if engineering purposes require compaction. Backblading or smoothing of slopes greater than 4H:1V is not allowed if they are to be seeded.
- Restoration-based landscape practices require deeper incorporation than that provided by a simple single-pass rototilling treatment. Wherever practical, initially rip the subgrade to improve long-term permeability, infiltration, and water inflow qualities. At a minimum,

permanent areas shall use soil amendments to achieve organic matter and permeability performance defined in engineered soil/landscape systems. For systems that are deeper than 8 inches complete the rototilling process in multiple lifts, or prepare the engineered soil system per specifications and place to achieve the specified depth.

Fertilizers

- Conducting soil tests to determine the exact type and quantity of fertilizer is recommended. This will prevent the over-application of fertilizer.
- Organic matter is the most appropriate form of fertilizer because it provides nutrients (including nitrogen, phosphorus, and potassium) in the least water-soluble form.
- In general, use 10-4-6 N-P-K (nitrogen-phosphorus-potassium) fertilizer at a rate of 90 pounds per acre. Always use slow-release fertilizers because they are more efficient and have fewer environmental impacts. Do not add fertilizer to the hydromulch machine, or agitate, more than 20 minutes before use. Too much agitation destroys the slow-release coating.
- There are numerous products available that take the place of chemical fertilizers. These include several with seaweed extracts that are beneficial to soil microbes and organisms. If 100 percent cottonseed meal is used as the mulch in hydroseed, chemical fertilizer may not be necessary. Cottonseed meal provides a good source of long-term, slow-release, available nitrogen.

Bonded Fiber Matrix and Mechanically Bonded Fiber Matrix

- On steep slopes use Bonded Fiber Matrix (BFM) or Mechanically Bonded Fiber Matrix (MBFM) products. Apply BFM/MBFM products at a minimum rate of 3,000 pounds per acre with approximately 10 percent tackifier. Achieve a minimum of 95 percent soil coverage during application. Numerous products are available commercially. Most products require 24-36 hours to cure before rainfall and cannot be installed on wet or saturated soils. Generally, products come in 40-50 pound bags and include all necessary ingredients except for seed and fertilizer.
- Install products per manufacturer's instructions.
- BFMs and MBFMs provide good alternatives to blankets in most areas requiring vegetation establishment. Advantages over blankets include:
 - BFM and MBFMs do not require surface preparation.
 - Helicopters can assist in installing BFM and MBFMs in remote areas.
 - On slopes steeper than 2.5H:1V, blanket installers may require ropes and harnesses for safety.
 - Installing BFM and MBFMs can save at least \$1,000 per acre compared to blankets.

Maintenance Standards

Reseed any seeded areas that fail to establish at least 75 percent cover (100 percent cover for areas that receive sheet or concentrated flows). If reseeding is ineffective, use an alternate method such as sodding, mulching, nets, or blankets.

- Reseed and protect by mulch any areas that experience erosion after achieving adequate cover. Reseed and protect by mulch any eroded area.
- Supply seeded areas with adequate moisture, but do not water to the extent that it causes run-off.

Approved as Functionally Equivalent

Ecology has approved products as able to meet the requirements of this BMP. The products did not pass through the Technology Assessment Protocol – Ecology (TAPE) process. Local jurisdictions may choose not to accept these products, or may require additional testing prior to consideration for local use. Products that Ecology has approved as functionally equivalent are available for review on Ecology’s website at:

<https://ecology.wa.gov/Regulations-Permits/Guidance-technical-assistance/Stormwater-permittee-guidance-resources/Emerging-stormwater-treatment-technologies>

BMP C121: Mulching

Purpose

Mulching soils provides immediate temporary protection from erosion. Mulch also enhances plant establishment by conserving moisture, holding fertilizer, seed, and topsoil in place, and moderating soil temperatures. There are a variety of mulches that can be used. This section discusses only the most common types of mulch.

Conditions of Use

As a temporary cover measure, mulch should be used:

- For less than 30 days on disturbed areas that require cover.
- At all times for seeded areas, especially during the wet season and during the hot summer months.
- During the wet season on slopes steeper than 3H:1V with more than 10 feet of vertical relief.

Mulch may be applied at any time of the year and must be refreshed periodically.

For seeded areas, mulch may be made up of 100 percent:

- cottonseed meal;
- fibers made of wood, recycled cellulose, hemp, or kenaf;

- compost;
- or blends of these.

Tackifier shall be plant-based, such as guar or alpha plantago, or chemical-based such as polyacrylamide or polymers.

Generally, mulches come in 40-50 pound bags. Seed and fertilizer are added at time of application.

Recycled cellulose may contain polychlorinated biphenyl (PCBs). Ecology recommends that products should be evaluated for PCBs prior to use.

Refer to [BMP C126: Polyacrylamide \(PAM\) for Soil Erosion Protection](#) for conditions of use. PAM shall not be directly applied to water or allowed to enter a water body.

Any mulch or tackifier product used shall be installed per the manufacturer’s instructions.

Design and Installation Specifications

For mulch materials, application rates, and specifications, see [Table II-3.6: Mulch Standards and Guidelines](#). Consult with the local supplier or the local conservation district for their recommendations. Increase the application rate until the ground is 95% covered (i.e. not visible under the mulch layer). Note: Thickness may be increased for disturbed areas in or near sensitive areas or other areas highly susceptible to erosion.

Where the option of “Compost” is selected, it should be a coarse compost that meets the size gradations listed in [Table II-3.5: Size Gradations of Compost as Mulch Material](#) when tested in accordance with Test Method 02.02-B found in *Test Methods for the Examination of Composting and Compost* (Thompson, 2001).

Table II-3.5: Size Gradations of Compost as Mulch Material

Sieve Size	Percent Passing
3"	100%
1"	90% - 100%
3/4"	70% - 100%
1/4"	40% - 100%

Mulch used within the ordinary high-water mark of surface waters should be selected to minimize potential flotation of organic matter. Composted organic materials have higher specific gravities (densities) than straw, wood, or chipped material. Consult the Hydraulic Permit Authority (HPA) for mulch mixes if applicable.

Maintenance Standards

The thickness of the mulch cover must be maintained.

Any areas that experience erosion shall be remulched and/or protected with a net or blanket. If the erosion problem is drainage related, then the problem shall be fixed and the eroded area remulched.

Table II-3.6: Mulch Standards and Guidelines

Mulch Material	Guideline	Description
Straw	Quality Standards	Air-dried; free from undesirable seed and coarse material.
	Application Rates	2"-3" thick; 5 bales per 1,000 sf or 2-3 tons per acre
	Remarks	Cost-effective protection when applied with adequate thickness. Hand-application generally requires greater thickness than blown straw. The thickness of straw may be reduced by half when used in conjunction with seeding. In windy areas straw must be held in place by crimping, using a tackifier, or covering with netting. Blown straw always has to be held in place with a tackifier as even light winds will blow it away. Straw, however, has several deficiencies that should be considered when selecting mulch materials. It often introduces and/or encourages the propagation of weed species and it has no significant long-term benefits. It should also not be used within the ordinary high-water elevation of surface waters (due to flotation).
Hydromulch	Quality Standards	No growth inhibiting factors.
	Application Rates	Approx. 35-45 lbs per 1,000 sf or 1,500 - 2,000 lbs per acre
	Remarks	Shall be applied with hydromulcher. Shall not be used without seed and tackifier unless the application rate is at least doubled. Fibers longer than about 3/4 - 1 inch clog hydromulch equipment. Fibers should be kept to less than 3/4 inch.
Compost	Quality Standards	No visible water or dust during handling. Must be produced per WAC 173-350 , Solid Waste Handling Standards, but may have up to 35% biosolids.
	Application Rates	2" thick min.; approx. 100 tons per acre (approx. 750 lbs per cubic yard)
	Remarks	More effective control can be obtained by increasing thickness to 3". Excellent mulch for protecting final grades until landscaping because it can be directly seeded or tilled into soil as an amendment. Compost used for mulch has a coarser size gradation than compost used for BMP C125: Topsoiling / Composting or BMP T5.13: Post-Construction Soil Quality and Depth . It is more stable and practical to use in wet areas and during rainy weather conditions. Do not use near wetlands or near phosphorous impaired water bodies.
Chipped Site Vegetation	Quality Standards	Gradations from fines to 6 inches in length for texture, variation, and interlocking properties. Include a mix of various sizes so that the average size is between 2- and 4- inches.
	Application Rates	2" thick min.;

Table II-3.6: Mulch Standards and Guidelines (continued)

Mulch Material	Guideline	Description
	Remarks	<p>This is a cost-effective way to dispose of debris from clearing and grubbing, and it eliminates the problems associated with burning. Generally, it should not be used on slopes above approx. 10% because of its tendency to be transported by runoff. It is not recommended within 200 feet of surface waters. If permanent seeding or planting is expected shortly after mulch, the decomposition of the chipped vegetation may tie up nutrients important to grass establishment.</p> <p>Note: thick application of this material over existing grass, herbaceous species, and some groundcovers could smother and kill vegetation.</p>
Wood-Based Mulch	Quality Standards	No visible water or dust during handling. Must be purchased from a supplier with a Solid Waste Handling Permit or one exempt from solid waste regulations.
	Application Rates	2" thick min.; approx. 100 tons per acre (approx. 750 lbs. per cubic yard)
	Remarks	This material is often called "wood straw" or "hog fuel". The use of mulch ultimately improves the organic matter in the soil. Special caution is advised regarding the source and composition of wood-based mulches. Its preparation typically does not provide any weed seed control, so evidence of residual vegetation in its composition or known inclusion of weed plants or seeds should be monitored and prevented (or minimized).
Wood Strand Mulch	Quality Standards	A blend of loose, long, thin wood pieces derived from native conifer or deciduous trees with high length-to-width ratio.
	Application Rates	2" thick min.
	Remarks	Cost-effective protection when applied with adequate thickness. A minimum of 95-percent of the wood strand shall have lengths between 2 and 10-inches, with a width and thickness between 1/16 and 1/2-inches. The mulch shall not contain resin, tannin, or other compounds in quantities that would be detrimental to plant life. Sawdust or wood shavings shall not be used as mulch. [Specification 9-14.4(4) from the <i>Standard Specifications for Road, Bridge, and Municipal Construction</i> (WSDOT, 2016)

BMP C122: Nets and Blankets

Purpose

Erosion control nets and blankets are intended to prevent erosion and hold seed and mulch in place on steep slopes and in channels so that vegetation can become well established. In addition, some nets and blankets can be used to permanently reinforce turf to protect drainage ways during high flows.

Nets (commonly called matting) are strands of material woven into an open, but high-tensile strength net (for example, coconut fiber matting). Blankets are strands of material that are not tightly woven, but instead form a layer of interlocking fibers, typically held together by a biodegradable or photodegradable netting (for example, excelsior or straw blankets). They generally have lower tensile strength than nets, but cover the ground more completely. Coir (coconut fiber) fabric comes as both nets and blankets.

Conditions of Use

Erosion control netting and blankets shall be made of natural plant fibers unaltered by synthetic materials.

Erosion control nets and blankets should be used:

- To aid permanent vegetated stabilization of slopes 2H:1V or greater and with more than 10 feet of vertical relief.
- For drainage ditches and swales (highly recommended). The application of appropriate netting or blanket to drainage ditches and swales can protect bare soil from channelized runoff while vegetation is established. Nets and blankets also can capture a great deal of sediment due to their open, porous structure. Nets and blankets can be used to permanently stabilize channels and may provide a cost-effective, environmentally preferable alternative to riprap.

Disadvantages of nets and blankets include:

- Surface preparation is required.
- On slopes steeper than 2.5H:1V, net and blanket installers may need to be roped and harnessed for safety.
- They cost at least \$4,000-6,000 per acre installed.

Advantages of nets and blankets include:

- Installation without mobilizing special equipment.
- Installation by anyone with minimal training
- Installation in stages or phases as the project progresses.
- Installers can hand place seed and fertilizer as they progress down the slope.
- Installation in any weather.
- There are numerous types of nets and blankets that can be designed with various parameters in mind. Those parameters include: fiber blend, mesh strength, longevity, biodegradability, cost, and availability.

An alternative to nets and blankets in some limited conditions is [BMP C202: Riprap Channel Lining](#). Ensure that [BMP C202: Riprap Channel Lining](#) is appropriate before using it as a substitute for nets and blankets.

Design and Installation Specifications

- See [Figure II-3.3: Channel Installation \(Clackamas County et al., 2008\)](#) and [Figure II-3.4: Slope Installation](#) for typical orientation and installation of nets and blankets used in channels and as slope protection. Note: these are typical only; all nets and blankets must be installed per manufacturer's installation instructions.
- Installation is critical to the effectiveness of these products. If good ground contact is not achieved, runoff can concentrate under the product, resulting in significant erosion.
- Installation of nets and blankets on slopes:
 1. Complete final grade and track walk up and down the slope.
 2. Install hydromulch with seed and fertilizer.
 3. Dig a small trench, approximately 12 inches wide by 6 inches deep along the top of the slope.
 4. Install the leading edge of the net/blanket into the small trench and staple approximately every 18 inches. NOTE: Staples are metal, "U"-shaped, and a minimum of 6 inches long. Longer staples are used in sandy soils. Biodegradable stakes are also available.
 5. Roll the net/blanket slowly down the slope as the installer walks backward. NOTE: The net/blanket rests against the installer's legs. Staples are installed as the net/blanket is unrolled. It is critical that the proper staple pattern is used for the net/blanket being installed. The net/blanket is not to be allowed to roll down the slope on its own as this stretches the net/blanket, making it impossible to maintain soil contact. In addition, no one is allowed to walk on the net/blanket after it is in place.
 6. If the net/blanket is not long enough to cover the entire slope length, the trailing edge of the upper net/blanket should overlap the leading edge of the lower net/blanket and be stapled. On steeper slopes, this overlap should be installed in a small trench, stapled, and covered with soil.
- With the variety of products available, it is impossible to cover all the details of appropriate use and installation. Therefore, it is critical that the designer consult the manufacturer's information and that a site visit takes place in order to ensure that the product specified is appropriate. Information is also available in WSDOT's *Standard Specifications for Road, Bridge, and Municipal Construction* Division 8-01 and Division 9-14 ([WSDOT, 2016](#)).
- Use jute matting in conjunction with mulch ([BMP C121: Mulching](#)). Excelsior, woven straw blankets and coir (coconut fiber) blankets may be installed without mulch. There are many other types of erosion control nets and blankets on the market that may be appropriate in certain circumstances.
- In general, most nets (e.g., jute matting) require mulch in order to prevent erosion because they have a fairly open structure. Blankets typically do not require mulch because they usually provide complete protection of the surface.
- Extremely steep, unstable, wet, or rocky slopes are often appropriate candidates for use of synthetic blankets, as are riverbanks, beaches and other high-energy environments. If

synthetic blankets are used, the soil should be hydromulched first.

- 100-percent biodegradable blankets are available for use in sensitive areas. These organic blankets are usually held together with a paper or fiber mesh and stitching which may last up to a year.
- Most netting used with blankets is photodegradable, meaning it breaks down under sunlight (not UV stabilized). However, this process can take months or years even under bright sun. Once vegetation is established, sunlight does not reach the mesh. It is not uncommon to find non-degraded netting still in place several years after installation. This can be a problem if maintenance requires the use of mowers or ditch cleaning equipment. In addition, birds and small animals can become trapped in the netting.

Maintenance Standards

- Maintain good contact with the ground. Erosion must not occur beneath the net or blanket.
- Repair and staple any areas of the net or blanket that are damaged or not in close contact with the ground.
- Fix and protect eroded areas if erosion occurs due to poorly controlled drainage.

Figure II-3.3: Channel Installation

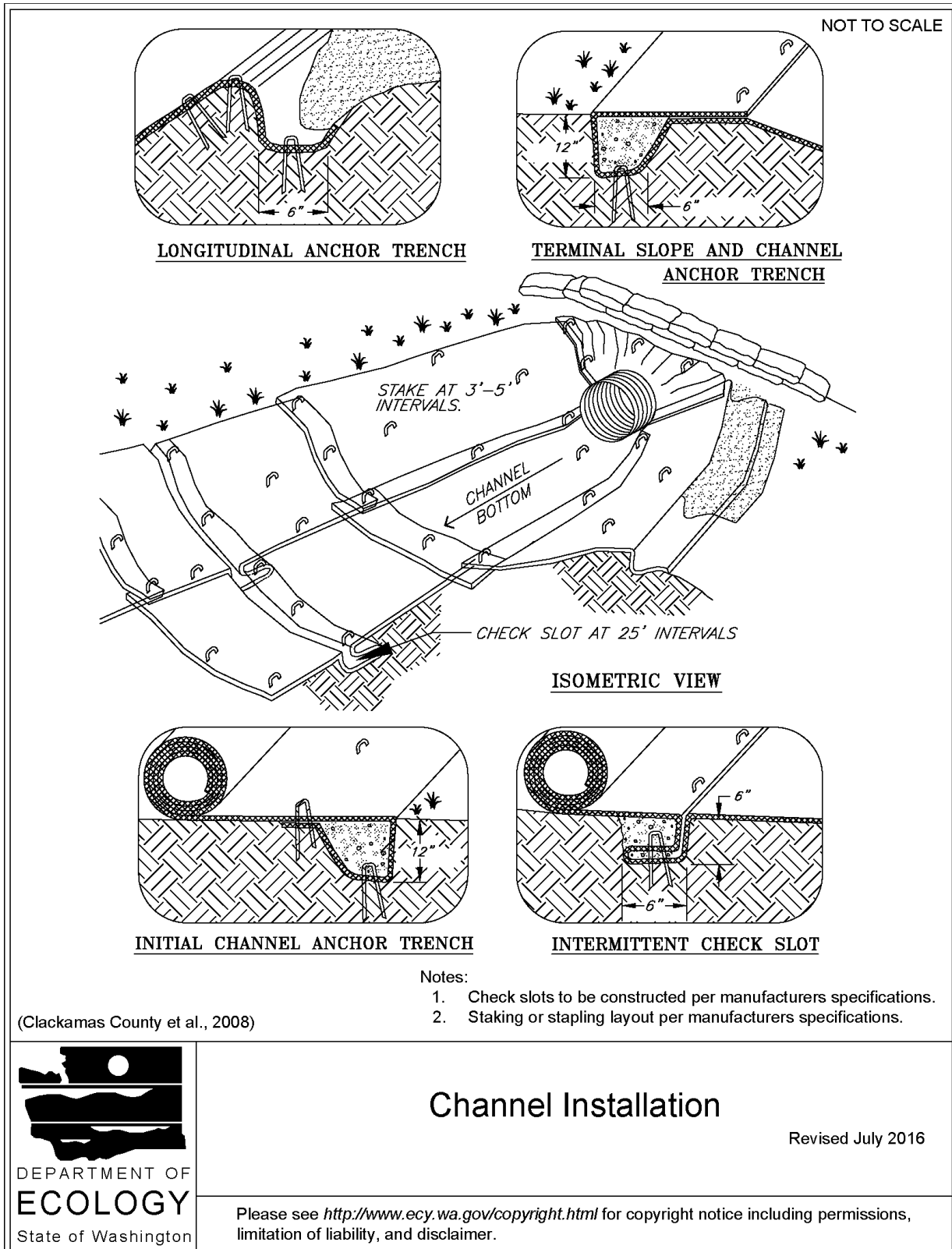
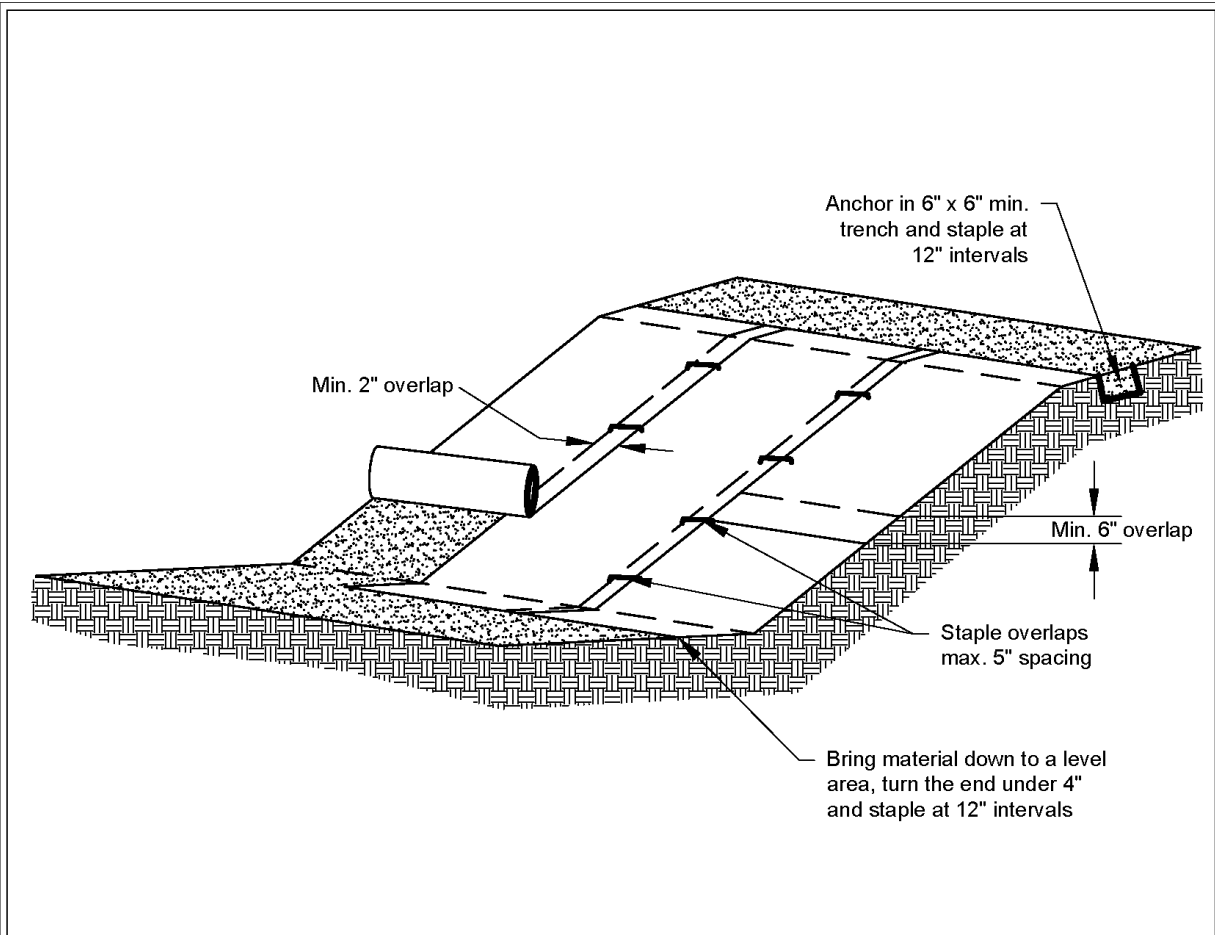

Figure II-3.4: Slope Installation



Notes:

1. Slope surface shall be smooth before placement for proper soil contact.
2. Stapling pattern as per manufacturer's recommendations.
3. Do not stretch blankets/matting tight - allow the rolls to mold to any irregularities.
4. For slopes less than 3H:1V, rolls may be placed in horizontal strips.
5. If there is a berm at the top of the slope, anchor upslope of the berm.
6. Lime, fertilize, and seed before installation. Planting of shrubs, trees, etc. should occur after installation.

NOT TO SCALE



Slope Installation

Revised June 2016

Please see <http://www.ecy.wa.gov/copyright.html> for copyright notice including permissions, limitation of liability, and disclaimer.

BMP C123: Plastic Covering

Purpose

Plastic covering provides immediate, short-term erosion protection to slopes and disturbed areas.

Conditions of Use

Plastic covering may be used on disturbed areas that require cover measures for less than 30 days, except as stated below.

- Plastic is particularly useful for protecting cut and fill slopes and stockpiles. However, the relatively rapid breakdown of most polyethylene sheeting makes it unsuitable for applications greater than six months.
- Due to rapid runoff caused by plastic covering, do not use this method upslope of areas that might be adversely impacted by concentrated runoff. Such areas include steep and/or unstable slopes.
- Plastic sheeting may result in increased runoff volumes and velocities, requiring additional on-site measures to counteract the increases. Creating a trough with wattles or other material can convey clean water away from these areas.
- To prevent undercutting, trench and backfill rolled plastic covering products.
- Although the plastic material is inexpensive to purchase, the cost of installation, maintenance, removal, and disposal add to the total costs of this BMP.
- Whenever plastic is used to protect slopes, install water collection measures at the base of the slope. These measures include plastic-covered berms, channels, and pipes used to convey clean rainwater away from bare soil and disturbed areas. Do not mix clean runoff from a plastic covered slope with dirty runoff from a project.
- Other uses for plastic include:
 - Temporary ditch liner.
 - Pond liner in temporary sediment pond.
 - Liner for bermed temporary fuel storage area if plastic is not reactive to the type of fuel being stored.
 - Emergency slope protection during heavy rains.
 - Temporary drainpipe (“elephant trunk”) used to direct water.

Design and Installation Specifications

- Plastic slope cover must be installed as follows:
 1. Run plastic up and down the slope, not across the slope.
 2. Plastic may be installed perpendicular to a slope if the slope length is less than 10 feet.

3. Provide a minimum of 8-inch overlap at the seams.
 4. On long or wide slopes, or slopes subject to wind, tape all seams.
 5. Place plastic into a small (12-inch wide by 6-inch deep) slot trench at the top of the slope and backfill with soil to keep water from flowing underneath.
 6. Place sand filled burlap or geotextile bags every 3 to 6 feet along seams and tie them together with twine to hold them in place.
 7. Inspect plastic for rips, tears, and open seams regularly and repair immediately. This prevents high velocity runoff from contacting bare soil, which causes extreme erosion.
 8. Sandbags may be lowered into place tied to ropes. However, all sandbags must be staked in place.
- Plastic sheeting shall have a minimum thickness of 0.06 millimeters.
 - If erosion at the toe of a slope is likely, a gravel berm, riprap, or other suitable protection shall be installed at the toe of the slope in order to reduce the velocity of runoff.

Maintenance Standards

- Torn sheets must be replaced and open seams repaired.
- Completely remove and replace the plastic if it begins to deteriorate due to ultraviolet radiation.
- Completely remove plastic when no longer needed.
- Dispose of old tires used to weight down plastic sheeting appropriately.

Approved as Functionally Equivalent

Ecology has approved products as able to meet the requirements of this BMP. The products did not pass through the Technology Assessment Protocol – Ecology (TAPE) process. Local jurisdictions may choose not to accept these products, or may require additional testing prior to consideration for local use. Products that Ecology has approved as functionally equivalent are available for review on Ecology's website at:

<https://ecology.wa.gov/Regulations-Permits/Guidance-technical-assistance/Stormwater-permittee-guidance-resources/Emerging-stormwater-treatment-technologies>

BMP C124: Sodding

Purpose

The purpose of sodding is to establish turf for immediate erosion protection and to stabilize drainage paths where concentrated overland flow will occur.

Conditions of Use

Sodding may be used in the following areas:

- Disturbed areas that require short-term or long-term cover.
- Disturbed areas that require immediate vegetative cover.
- All waterways that require vegetative lining. Waterways may also be seeded rather than sodded, and protected with a net or blanket.

Design and Installation Specifications

Sod shall be free of weeds, of uniform thickness (approximately 1-inch thick), and shall have a dense root mat for mechanical strength.

The following steps are recommended for sod installation:

1. Shape and smooth the surface to final grade in accordance with the approved grading plan. Consider any areas (such as swales) that need to be overexcavated below design elevation to allow room for placing soil amendment and sod.
2. Amend 4 inches (minimum) of compost into the top 8 inches of the soil if the organic content of the soil is less than ten percent or the permeability is less than 0.6 inches per hour. See <https://ecology.wa.gov/Waste-Toxics/Reducing-recycling-waste/Organic-materials/Managing-organics-compost> for further information.
3. Fertilize according to the sod supplier's recommendations.
4. Work lime and fertilizer 1 to 2 inches into the soil, and smooth the surface.
5. Lay strips of sod beginning at the lowest area to be sodded and perpendicular to the direction of water flow. Wedge strips securely into place. Square the ends of each strip to provide for a close, tight fit. Stagger joints at least 12 inches. Staple on slopes steeper than 3H:1V. Staple the upstream edge of each sod strip.
6. Roll the sodded area and irrigate.
7. When sodding is carried out in alternating strips or other patterns, seed the areas between the sod immediately after sodding.

Maintenance Standards

If the grass is unhealthy, the cause shall be determined and appropriate action taken to reestablish a healthy groundcover. If it is impossible to establish a healthy groundcover due to frequent saturation, instability, or some other cause, the sod shall be removed, the area seeded with an appropriate mix, and protected with a net or blanket.

BMP C125: Topsoiling / Composting

Purpose

Topsoiling and composting provide a suitable growth medium for final site stabilization with vegetation. While not a permanent cover practice in itself, topsoiling and composting are an integral component of providing permanent cover in those areas where there is an unsuitable soil surface for plant growth. Use this BMP in conjunction with other BMPs such as [BMP C120: Temporary and Permanent Seeding](#), [BMP C121: Mulching](#), or [BMP C124: Sodding](#). Implementation of this BMP may meet the post-construction requirements of [BMP T5.13: Post-Construction Soil Quality and Depth](#).

Native soils and disturbed soils that have been organically amended not only retain much more stormwater, but also serve as effective biofilters for urban pollutants and, by supporting more vigorous plant growth, reduce the water, fertilizer and pesticides needed to support installed landscapes. Topsoil does not include any subsoils but only the material from the top several inches including organic debris.

Conditions of Use

- Permanent landscaped areas shall contain healthy topsoil that reduces the need for fertilizers, improves overall topsoil quality, provides for better vegetative health and vitality, improves hydrologic characteristics, and reduces the need for irrigation.
- Leave native soils and the duff layer undisturbed to the maximum extent practicable. Stripping of existing, properly functioning soil system and vegetation for the purpose of topsoiling during construction is not acceptable. Preserve existing soil systems in undisturbed and uncompacted conditions if functioning properly.
- Areas that already have good topsoil, such as undisturbed areas, do not require soil amendments.
- Restore, to the maximum extent practical, native soils disturbed during clearing and grading to a condition equal to or better than the original site condition's moisture-holding capacity. Use on-site native topsoil, incorporate amendments into on-site soil, or import blended topsoil to meet this requirement.
- Topsoiling is a required procedure when establishing vegetation on shallow soils, and soils of critically low pH (high acid) levels.
- Beware of where the topsoil comes from, and what vegetation was on site before disturbance. Invasive plant seeds may be included and could cause problems for establishing native plants, landscaped areas, or grasses.
- Topsoil from the site will contain mycorrhizal bacteria that are necessary for healthy root growth and nutrient transfer. These native mycorrhiza are acclimated to the site and will provide optimum conditions for establishing grasses. Use commercially available mycorrhiza products when using off-site topsoil.

Design and Installation Specifications

Meet the following requirements for disturbed areas that will be developed as lawn or landscaped areas at the completed project site:

- Maximize the depth of the topsoil wherever possible to provide the maximum possible infiltration capacity and beneficial growth medium. Topsoil shall have:
 - A minimum depth of 8-inches. Scarify subsoils below the topsoil layer at least 4-inches with some incorporation of the upper material to avoid stratified layers, where feasible. Ripping or re-structuring the subgrade may also provide additional benefits regarding the overall infiltration and interflow dynamics of the soil system.
 - A minimum organic content of 10% dry weight in planting beds, and 5% organic matter content in turf areas. Incorporate organic amendments to a minimum 8-inch depth except where tree roots or other natural features limit the depth of incorporation.
 - A pH between 6.0 and 8.0 or matching the pH of the undisturbed soil.
 - If blended topsoil is imported, then fines should be limited to 25 percent passing through a 200 sieve.
- Mulch planting beds with 2 inches of organic material
- Accomplish the required organic content, depth, and pH by returning native topsoil to the site, importing topsoil of sufficient organic content, and/or incorporating organic amendments. When using the option of incorporating amendments to meet the organic content requirement, use compost that meets the compost specification for Bioretention (See [BMP T7.30: Bioretention](#)), with the exception that the compost may have up to 35% biosolids or manure.
- Sections 3 through 7 of *Building Soil: Guidelines and Resources for Implementing Soil Quality and Depth BMP T5.13 in WDOE Stormwater Management Manual for Western Washington (Stenn et al., 2016)*, provides useful guidance for implementing whichever option is chosen. It includes guidance for pre-approved default strategies and guidance for custom strategies. Check with your local jurisdiction concerning its acceptance of this guidance.
- The final composition and construction of the soil system will result in a natural selection or favoring of certain plant species over time. For example, incorporation of topsoil may favor grasses, while layering with mildly acidic, high-carbon amendments may favor more woody vegetation.
- Allow sufficient time in scheduling for topsoil spreading prior to seeding, sodding, or planting.
- Take care when applying top soil to subsoils with contrasting textures. Sandy topsoil over clayey subsoil is a particularly poor combination, as water creeps along the junction between the soil layers and causes the topsoil to slough. If topsoil and subsoil are not properly bonded, water will not infiltrate the soil profile evenly and it will be difficult to establish vegetation. The best method to promote bonding is to actually work the topsoil into the layer below for a depth of at least 6 inches.
- Field exploration of the site shall be made to determine if there is surface soil of sufficient quantity and quality to justify stripping. Topsoil shall be friable and loamy (loam, sandy loam,

silt loam, sandy clay loam, and clay loam). Avoid areas of natural ground water recharge.

- Stripping shall be confined to the immediate construction area. A 4-inch to 6-inch stripping depth is common, but depth may vary depending on the particular soil. All surface runoff control structures shall be in place prior to stripping.
- Do not place topsoil while in a frozen or muddy condition, when the subgrade is excessively wet, or when conditions exist that may otherwise be detrimental to proper grading or proposed sodding or seeding.
- In any areas requiring grading, remove and stockpile the duff layer and topsoil on site in a designated, controlled area, not adjacent to public resources and critical areas. Reapply stockpiled topsoil to other portions of the site where feasible.
- Locate the topsoil stockpile so that it meets specifications and does not interfere with work on the site. It may be possible to locate more than one pile in proximity to areas where topsoil will be used.
- Stockpiling of topsoil shall occur in the following manner:
 - Side slopes of the stockpile shall not exceed 2H:1V.
 - Between October 1 and April 30:
 - An interceptor dike with gravel outlet and silt fence shall surround all topsoil.
 - Within 2 days complete erosion control seeding, or covering stockpiles with clear plastic, or other mulching materials.
 - Between May 1 and September 30:
 - An interceptor dike with gravel outlet and silt fence shall surround all topsoil if the stockpile will remain in place for a longer period of time than active construction grading.
 - Within 7 days complete erosion control seeding, or covering stockpiles with clear plastic, or other mulching materials.
- When native topsoil is to be stockpiled and reused the following should apply to ensure that the mycorrhizal bacterial, earthworms, and other beneficial organisms will not be destroyed:
 - Re-install topsoil within 4 to 6 weeks.
 - Do not allow the saturation of topsoil with water.
 - Do not use plastic covering.

Maintenance Standards

- Inspect stockpiles regularly, especially after large storm events. Stabilize any areas that have eroded.
- Establish soil quality and depth toward the end of construction and once established, protect from compaction, such as from large machinery use, and from erosion.

- Plant and mulch soil after installation.
- Leave plant debris or its equivalent on the soil surface to replenish organic matter.
- Reduce and adjust, where possible, the use of irrigation, fertilizers, herbicides and pesticides, rather than continuing to implement formerly established practices.

BMP C140: Dust Control

Purpose

Dust control prevents wind transport of dust from disturbed soil surfaces onto roadways, drainage ways, and surface waters.

Conditions of Use

Use dust control in areas (including roadways) subject to surface and air movement of dust where on-site or off-site impacts to roadways, drainage ways, or surface waters are likely.

Design and Installation Specifications

- Vegetate or mulch areas that will not receive vehicle traffic. In areas where planting, mulching, or paving is impractical, apply gravel or landscaping rock.
- Limit dust generation by clearing only those areas where immediate activity will take place, leaving the remaining area(s) in the original condition. Maintain the original ground cover as long as practical.
- Construct natural or artificial windbreaks or windscreens. These may be designed as enclosures for small dust sources.
- Sprinkle the site with water until the surface is wet. Repeat as needed. To prevent carryout of mud onto the street, refer to [BMP C 105: Stabilized Construction Access](#) and [BMP C 106: Wheel Wash](#).
- Irrigation water can be used for dust control. Irrigation systems should be installed as a first step on sites where dust control is a concern.
- Spray exposed soil areas with a dust palliative, following the manufacturer's instructions and cautions regarding handling and application. Used oil is prohibited from use as a dust suppressant. Local governments may approve other dust palliatives such as calcium chloride or PAM.
- PAM ([BMP C 126: Polyacrylamide \(PAM\) for Soil Erosion Protection](#)) added to water at a rate of 0.5 pounds per 1,000 gallons of water per acre and applied from a water truck is more effective than water alone. This is due to increased infiltration of water into the soil and reduced evaporation. In addition, small soil particles are bonded together and are not as easily transported by wind. Adding PAM may reduce the quantity of water needed for dust control. Note that the application rate specified here applies to this BMP, and is not the same application rate that is specified in [BMP C 126: Polyacrylamide \(PAM\) for Soil Erosion Protection](#), but the downstream protections still apply.

Refer to [BMP C 126: Polyacrylamide \(PAM\) for Soil Erosion Protection](#) for conditions of use. PAM shall not be directly applied to water or allowed to enter a water body.

- Contact your local Air Pollution Control Authority for guidance and training on other dust control measures. Compliance with the local Air Pollution Control Authority constitutes

compliance with this BMP.

- Use vacuum street sweepers.
- Remove mud and other dirt promptly so it does not dry and then turn into dust.
- Techniques that can be used for unpaved roads and lots include:
 - Lower speed limits. High vehicle speed increases the amount of dust stirred up from unpaved roads and lots.
 - Upgrade the road surface strength by improving particle size, shape, and mineral types that make up the surface and base materials.
 - Add surface gravel to reduce the source of dust emission. Limit the amount of fine particles (those smaller than .075 mm) to 10 to 20 percent.
 - Use geotextile fabrics to increase the strength of new roads or roads undergoing reconstruction.
 - Encourage the use of alternate, paved routes, if available.
 - Apply chemical dust suppressants using the admix method, blending the product with the top few inches of surface material. Suppressants may also be applied as surface treatments.
 - Limit dust-causing work on windy days.
 - Pave unpaved permanent roads and other trafficked areas.

Maintenance Standards

Respray area as necessary to keep dust to a minimum.

BMP C150: Materials on Hand

Purpose

Keep quantities of erosion prevention and sediment control materials on the project site at all times to be used for regular maintenance and emergency situations such as unexpected heavy rains. Having these materials on-site reduces the time needed to replace existing or implement new BMPs when inspections indicate that existing BMPs are not meeting the Construction SWPPP requirements. In addition, contractors can save money by buying some materials in bulk and storing them at their office or yard.

Conditions of Use

- Construction projects of any size or type can benefit from having materials on hand. A small commercial development project could have a roll of plastic and some gravel available for immediate protection of bare soil and temporary berm construction. A large earthwork project, such as highway construction, might have several tons of straw, several rolls of plastic, flexible

pipe, sandbags, geotextile fabric and steel “T” posts.

- Materials should be stockpiled and readily available before any site clearing, grubbing, or earthwork begins. A large contractor or project proponent could keep a stockpile of materials that are available for use on several projects.
- If storage space at the project site is at a premium, the contractor could maintain the materials at their office or yard. The office or yard must be less than an hour from the project site.

Design and Installation Specifications

Depending on project type, size, complexity, and length, materials and quantities will vary. A good minimum list of items that will cover numerous situations includes:

- Clear Plastic, 6 mil
- Drainpipe, 6 or 8 inch diameter
- Sandbags, filled
- Straw Bales for mulching
- Quarry Spalls
- Washed Gravel
- Geotextile Fabric
- Catch Basin Inserts
- Steel "T" Posts
- Silt fence material
- Straw Wattles

Maintenance Standards

- All materials with the exception of the quarry spalls, steel “T” posts, and gravel should be kept covered and out of both sun and rain.
- Re-stock materials as needed.

BMP C151: Concrete Handling

Purpose

Concrete work can generate process water and slurry that contain fine particles and high pH, both of which can violate water quality standards in the receiving water. Concrete spillage or concrete discharge to waters of the State is prohibited. Use this BMP to minimize and eliminate concrete, concrete process water, and concrete slurry from entering waters of the State.

Conditions of Use

Any time concrete is used, utilize these management practices. Concrete construction project components include, but are not limited to:

- Curbs
- Sidewalks
- Roads
- Bridges
- Foundations
- Floors
- Runways

Disposal options for concrete, in order of preference are:

1. Off-site disposal
2. Concrete wash-out areas (see [BMP C154: Concrete Washout Area](#))
3. De minimus washout to formed areas awaiting concrete

Design and Installation Specifications

- Wash concrete truck drums at an approved off-site location or in designated concrete washout areas only. Do not wash out concrete trucks onto the ground (including formed areas awaiting concrete), or into storm drains, open ditches, streets, or streams. Refer to [BMP C154: Concrete Washout Area](#) for information on concrete washout areas.
 - Return unused concrete remaining in the truck and pump to the originating batch plant for recycling. Do not dump excess concrete on site, except in designated concrete washout areas as allowed in [BMP C154: Concrete Washout Area](#).
- Wash small concrete handling equipment (e.g. hand tools, screeds, shovels, rakes, floats, trowels, and wheelbarrows) into designated concrete washout areas or into formed areas awaiting concrete pour.
- At no time shall concrete be washed off into the footprint of an area where an infiltration feature will be installed.
- Wash equipment difficult to move, such as concrete paving machines, in areas that do not directly drain to natural or constructed stormwater conveyance or potential infiltration areas.
- Do not allow washwater from areas, such as concrete aggregate driveways, to drain directly (without detention or treatment) to natural or constructed stormwater conveyances.
- Contain washwater and leftover product in a lined container when no designated concrete washout areas (or formed areas, allowed as described above) are available. Dispose of contained concrete and concrete washwater (process water) properly.

- Always use forms or solid barriers for concrete pours, such as pilings, within 15-feet of surface waters.
- Refer to [BMP C252: Treating and Disposing of High pH Water](#) for pH adjustment requirements.
- Refer to the Construction Stormwater General Permit (CSWGP) for pH monitoring requirements if the project involves one of the following activities:
 - Significant concrete work (as defined in the CSWGP).
 - The use of soils amended with (but not limited to) Portland cement-treated base, cement kiln dust or fly ash.
 - Discharging stormwater to segments of water bodies on the 303(d) list (Category 5) for high pH.

Maintenance Standards

Check containers for holes in the liner daily during concrete pours and repair the same day.

BMP C152: Sawcutting and Surfacing Pollution Prevention

Purpose

Sawcutting and surfacing operations generate slurry and process water that contains fine particles and high pH (concrete cutting), both of which can violate the water quality standards in the receiving water. Concrete spillage or concrete discharge to waters of the State is prohibited. Use this BMP to minimize and eliminate process water and slurry created through sawcutting or surfacing from entering waters of the State.

Conditions of Use

Utilize these management practices anytime sawcutting or surfacing operations take place. Sawcutting and surfacing operations include, but are not limited to:

- Sawing
- Coring
- Grinding
- Roughening
- Hydro-demolition
- Bridge and road surfacing

Design and Installation Specifications

- Vacuum slurry and cuttings during cutting and surfacing operations.
- Slurry and cuttings shall not remain on permanent concrete or asphalt pavement overnight.
- Slurry and cuttings shall not drain to any natural or constructed drainage conveyance including stormwater systems. This may require temporarily blocking catch basins.
- Dispose of collected slurry and cuttings in a manner that does not violate ground water or surface water quality standards.
- Do not allow process water generated during hydro-demolition, surface roughening or similar operations to drain to any natural or constructed drainage conveyance including stormwater systems. Dispose of process water in a manner that does not violate ground water or surface water quality standards.
- Handle and dispose of cleaning waste material and demolition debris in a manner that does not cause contamination of water. Dispose of sweeping material from a pick-up sweeper at an appropriate disposal site.

Maintenance Standards

Continually monitor operations to determine whether slurry, cuttings, or process water could enter waters of the state. If inspections show that a violation of water quality standards could occur, stop operations and immediately implement preventive measures such as berms, barriers, secondary containment, and/or vacuum trucks.

BMP C153: Material Delivery, Storage, and Containment

Purpose

Prevent, reduce, or eliminate the discharge of pollutants to the stormwater system or watercourses from material delivery and storage. Minimize the storage of hazardous materials on-site, store materials in a designated area, and install secondary containment.

Conditions of Use

Use at construction sites with delivery and storage of the following materials:

- Petroleum products such as fuel, oil and grease
- Soil stabilizers and binders (e.g., Polyacrylamide)
- Fertilizers, pesticides and herbicides
- Detergents
- Asphalt and concrete compounds

- Hazardous chemicals such as acids, lime, adhesives, paints, solvents, and curing compounds
- Any other material that may be detrimental if released to the environment

Design and Installation Specifications

- The temporary storage area should be located away from vehicular traffic, near the construction entrance(s), and away from waterways or storm drains.
- Safety Data Sheets (SDS) should be supplied for all materials stored. Chemicals should be kept in their original labeled containers.
- Hazardous material storage on-site should be minimized.
- Hazardous materials should be handled as infrequently as possible.
- During the wet weather season (Oct 1 – April 30), consider storing materials in a covered area.
- Materials should be stored in secondary containments, such as an earthen dike, horse trough, or even a children’s wading pool for non-reactive materials such as detergents, oil, grease, and paints. Small amounts of material may be secondarily contained in “bus boy” trays or concrete mixing trays.
- Do not store chemicals, drums, or bagged materials directly on the ground. Place these items on a pallet and, when possible, within secondary containment.
- If drums must be kept uncovered, store them at a slight angle to reduce ponding of rainwater on the lids to reduce corrosion. Domed plastic covers are inexpensive and snap to the top of drums, preventing water from collecting.
- Liquids, petroleum products, and substances listed in 40 CFR Parts 110, 117, or 302 shall be stored in approved containers and drums and shall not be overfilled. Containers and drums shall be stored in temporary secondary containment facilities.
- Temporary secondary containment facilities shall provide for a spill containment volume able to contain 10% of the total enclosed container volume of all containers, or 110% of the capacity of the largest container within its boundary, whichever is greater.
- Secondary containment facilities shall be impervious to the materials stored therein for a minimum contact time of 72 hours.
- Sufficient separation should be provided between stored containers to allow for spill cleanup and emergency response access.
- During the wet weather season (Oct 1 – April 30), each secondary containment facility shall be covered during non-working days, prior to and during rain events.
- Keep material storage areas clean, organized and equipped with an ample supply of appropriate spill clean-up material (spill kit).
- The spill kit should include, at a minimum:

- 1-Water Resistant Nylon Bag
- 3-Oil Absorbent Socks 3"x 4'
- 2-Oil Absorbent Socks 3"x 10'
- 12-Oil Absorbent Pads 17"x19"
- 1-Pair Splash Resistant Goggles
- 3-Pair Nitrile Gloves
- 10-Disposable Bags with Ties
- Instructions

Maintenance Standards

- Secondary containment facilities shall be maintained free of accumulated rainwater and spills. In the event of spills or leaks, accumulated rainwater and spills shall be collected and placed into drums. These liquids shall be handled as hazardous waste unless testing determines them to be non-hazardous.
- Re-stock spill kit materials as needed.

BMP C154: Concrete Washout Area

Purpose

Prevent or reduce the discharge of pollutants from concrete waste to stormwater by conducting washout off-site, or performing on-site washout in a designated area.

Conditions of Use

Concrete washout areas are implemented on construction projects where:

- Concrete is used as a construction material
- It is not possible to dispose of all concrete wastewater and washout off-site (ready mix plant, etc.).
- Concrete truck drums are washed on-site.

Note that auxiliary concrete truck components (e.g. chutes and hoses) and small concrete handling equipment (e.g. hand tools, screeds, shovels, rakes, floats, trowels, and wheelbarrows) may be washed into formed areas awaiting concrete pour.

At no time shall concrete be washed off into the footprint of an area where an infiltration feature will be installed.

Design and Installation Specifications

Implementation

- Perform washout of concrete truck drums at an approved off-site location or in designated concrete washout areas only.
- Do not wash out concrete onto non-formed areas, or into storm drains, open ditches, streets, or streams.
- Wash equipment difficult to move, such as concrete paving machines, in areas that do not directly drain to natural or constructed stormwater conveyance or potential infiltration areas.
- Do not allow excess concrete to be dumped on-site, except in designated concrete washout areas as allowed above.
- Concrete washout areas may be prefabricated concrete washout containers, or self-installed structures (above-grade or below-grade).
- Prefabricated containers are most resistant to damage and protect against spills and leaks. Companies may offer delivery service and provide regular maintenance and disposal of solid and liquid waste.
- If self-installed concrete washout areas are used, below-grade structures are preferred over above-grade structures because they are less prone to spills and leaks.
- Self-installed above-grade structures should only be used if excavation is not practical.
- Concrete washout areas shall be constructed and maintained in sufficient quantity and size to contain all liquid and concrete waste generated by washout operations.

Education

- Discuss the concrete management techniques described in this BMP with the ready-mix concrete supplier before any deliveries are made.
- Educate employees and subcontractors on the concrete waste management techniques described in this BMP.
- Arrange for the contractor's superintendent or Certified Erosion and Sediment Control Lead (CESCL) to oversee and enforce concrete waste management procedures.
- A sign should be installed adjacent to each concrete washout area to inform concrete equipment operators to utilize the proper facilities.

Contracts

Incorporate requirements for concrete waste management into concrete supplier and subcontractor agreements.

Location and Placement

- Locate concrete washout areas at least 50 feet from sensitive areas such as storm drains, open ditches, water bodies, or wetlands.
- Allow convenient access to the concrete washout area for concrete trucks, preferably near the area where the concrete is being poured.
- If trucks need to leave a paved area to access the concrete washout area, prevent track-out with a pad of rock or quarry spalls (see [BMP C105: Stabilized Construction Access](#)). These areas should be far enough away from other construction traffic to reduce the likelihood of accidental damage and spills.
- The number of concrete washout areas you install should depend on the expected demand for storage capacity.
- On large sites with extensive concrete work, concrete washout areas should be placed in multiple locations for ease of use by concrete truck drivers.

Concrete Truck Washout Procedures

- Washout of concrete truck drums shall be performed in designated concrete washout areas only.
- Concrete washout from concrete pumper bins can be washed into concrete pumper trucks and discharged into designated concrete washout areas or properly disposed of off-site.

Concrete Washout Area Installation

- Concrete washout areas should be constructed as shown in the figures below, with a recommended minimum length and minimum width of 10 ft, but with sufficient quantity and volume to contain all liquid and concrete waste generated by washout operations.
- Plastic lining material should be a minimum of 10 mil polyethylene sheeting and should be free of holes, tears, or other defects that compromise the impermeability of the material.
- Lath and flagging should be commercial type.
- Liner seams shall be installed in accordance with manufacturers' recommendations.
- Soil base shall be prepared free of rocks or other debris that may cause tears or holes in the plastic lining material.

Maintenance Standards

Inspection and Maintenance

- Inspect and verify that concrete washout areas are in place prior to the commencement of concrete work.
- Once concrete wastes are washed into the designated washout area and allowed to harden,

the concrete should be broken up, removed, and disposed of per applicable solid waste regulations. Dispose of hardened concrete on a regular basis.

- During periods of concrete work, inspect the concrete washout areas daily to verify continued performance.
 - Check overall condition and performance.
 - Check remaining capacity (% full).
 - If using self-installed concrete washout areas, verify plastic liners are intact and side-walls are not damaged.
 - If using prefabricated containers, check for leaks.
- Maintain the concrete washout areas to provide adequate holding capacity with a minimum freeboard of 12 inches.
- Concrete washout areas must be cleaned, or new concrete washout areas must be constructed and ready for use once the concrete washout area is 75% full.
- If the concrete washout area is nearing capacity, vacuum and dispose of the waste material in an approved manner.
 - Do not discharge liquid or slurry to waterways, storm drains or directly onto ground.
 - Do not discharge to the sanitary sewer without local approval.
 - Place a secure, non-collapsing, non-water collecting cover over the concrete washout area prior to predicted wet weather to prevent accumulation and overflow of precipitation.
 - Remove and dispose of hardened concrete and return the structure to a functional condition. Concrete may be reused on-site or hauled away for disposal or recycling.
- When you remove materials from a self-installed concrete washout area, build a new structure; or, if the previous structure is still intact, inspect for signs of weakening or damage, and make any necessary repairs. Re-line the structure with new plastic after each cleaning.

Removal of Concrete Washout Areas

- When concrete washout areas are no longer required for the work, the hardened concrete, slurries and liquids shall be removed and properly disposed of.
- Materials used to construct concrete washout areas shall be removed from the site of the work and disposed of or recycled.
- Holes, depressions or other ground disturbance caused by the removal of the concrete washout areas shall be backfilled, repaired, and stabilized to prevent erosion.

Figure II-3.7: Concrete Washout Area with Wood Planks

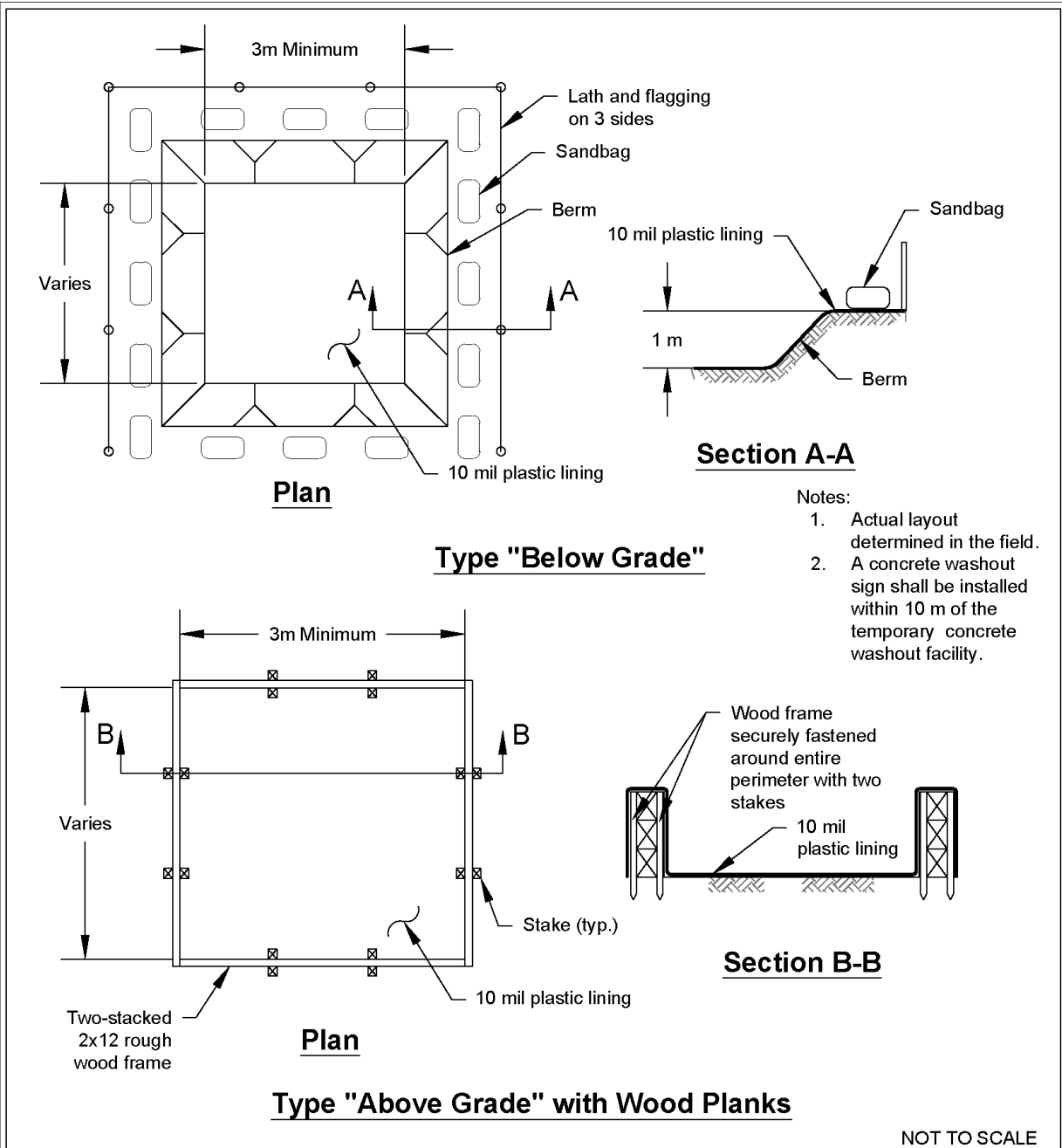

Concrete Washout Area with Wood Planks

Revised June 2016

Please see <http://www.ecy.wa.gov/copyright.html> for copyright notice including permissions, limitation of liability, and disclaimer.

Figure II-3.8: Concrete Washout Area with Straw Bales

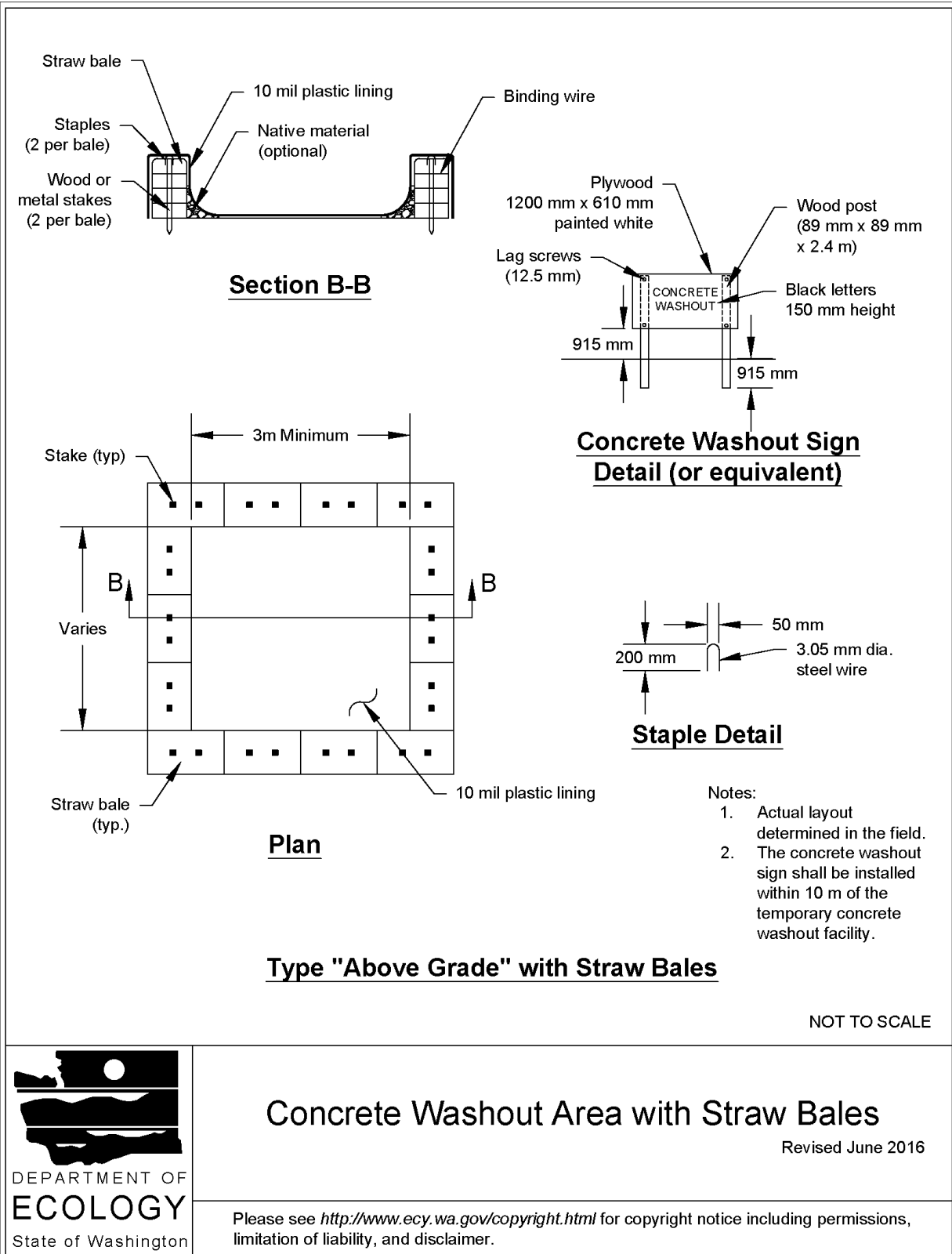

Concrete Washout Area with Straw Bales

Revised June 2016

Please see <http://www.ecy.wa.gov/copyright.html> for copyright notice including permissions, limitation of liability, and disclaimer.

Figure II-3.9: Prefabricated Concrete Washout Container w/Ramp

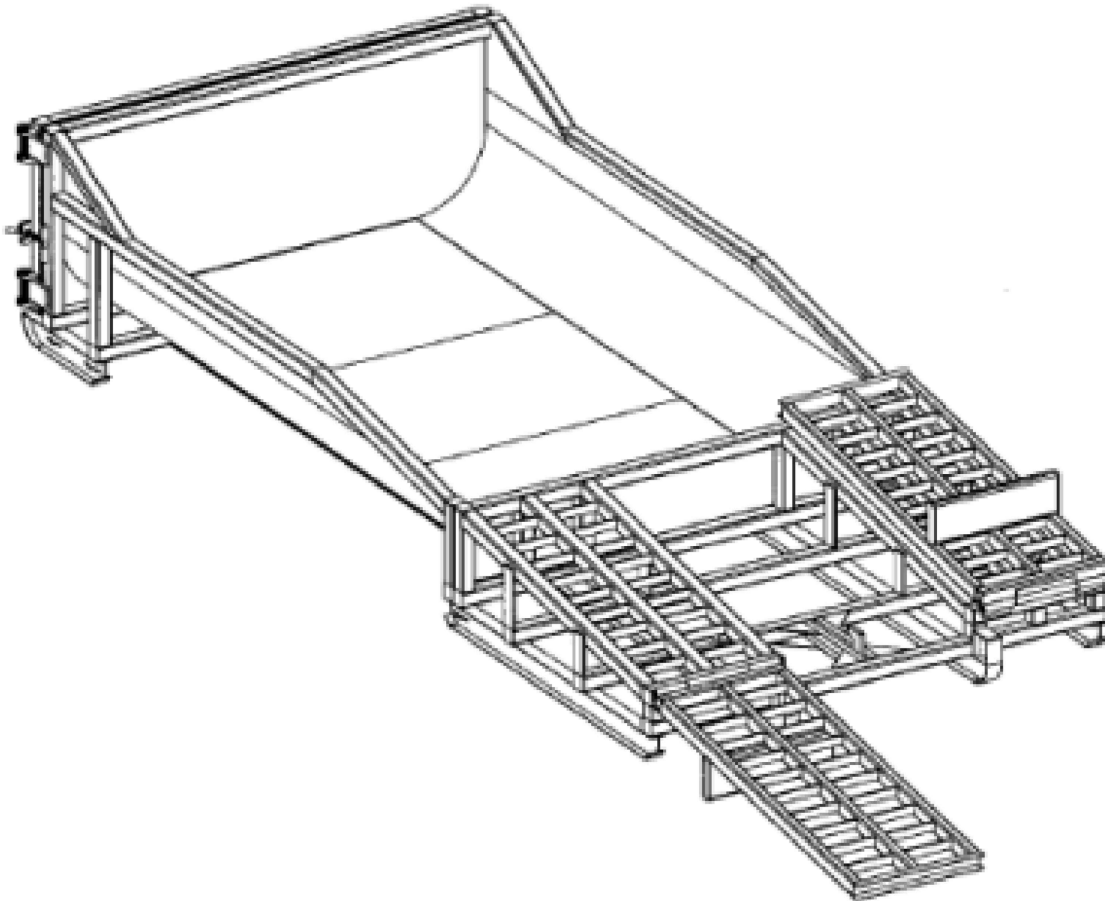

NOT TO SCALE



Prefabricated Concrete Washout Container w/Ramp

Revised June 2016

Please see <http://www.ecy.wa.gov/copyright.html> for copyright notice including permissions, limitation of liability, and disclaimer.

BMP C160: Certified Erosion and Sediment Control Lead

Purpose

The project proponent designates at least one person as the responsible representative in charge of erosion and sediment control (ESC), and water quality protection. The designated person shall be responsible for ensuring compliance with all local, state, and federal erosion and sediment control and water quality requirements. Construction sites one acre or larger that discharge to waters of the State must designate a Certified Erosion and Sediment Control Lead (CESCL) as the responsible representative.

Conditions of Use

A CESCL shall be made available on projects one acre or larger that discharge stormwater to surface waters of the state. Sites less than one acre may have a person without CESCL certification conduct inspections.

The CESCL shall:

- Have a current certificate proving attendance in an erosion and sediment control training course that meets the minimum ESC training and certification requirements established by Ecology.

Ecology has provided the minimum requirements for CESCL course training, as well as a list of ESC training and certification providers at:

<https://ecology.wa.gov/Regulations-Permits/Permits-certifications/Certified-erosion-sediment-control>

OR

- Be a Certified Professional in Erosion and Sediment Control (CPESC). For additional information go to:

<http://www.envirocertintl.org/cpesc/>

Specifications

- CESCL certification shall remain valid for three years.
- The CESCL shall have authority to act on behalf of the contractor or project proponent and shall be available, or on-call, 24 hours per day throughout the period of construction.
- The Construction SWPPP shall include the name, telephone number, fax number, and address of the designated CESCL. See [II-2 Construction Stormwater Pollution Prevention Plans \(Construction SWPPPs\)](#).
- A CESCL may provide inspection and compliance services for multiple construction projects in the same geographic region, but must be on site whenever earthwork activities are

occurring that could generate release of turbid water.

- Duties and responsibilities of the CESCL shall include, but are not limited to the following:
 - Maintaining a permit file on site at all times which includes the Construction SWPPP and any associated permits and plans.
 - Directing BMP installation, inspection, maintenance, modification, and removal.
 - Updating all project drawings and the Construction SWPPP with changes made.
 - Completing any sampling requirements including reporting results using electronic Discharge Monitoring Reports (WebDMR).
 - Facilitate, participate in, and take corrective actions resulting from inspections performed by outside agencies or the owner.
 - Keeping daily logs, and inspection reports. Inspection reports should include:
 - Inspection date/time.
 - Weather information; general conditions during inspection and approximate amount of precipitation since the last inspection.
 - Visual monitoring results, including a description of discharged stormwater. The presence of suspended sediment, turbid water, discoloration, and oil sheen shall be noted, as applicable.
 - Any water quality monitoring performed during inspection.
 - General comments and notes, including a brief description of any BMP repairs, maintenance or installations made as a result of the inspection.
 - A summary or list of all BMPs implemented, including observations of all erosion/sediment control structures or practices. The following shall be noted:
 1. Locations of BMPs inspected.
 2. Locations of BMPs that need maintenance.
 3. Locations of BMPs that failed to operate as designed or intended.
 4. Locations of where additional or different BMPs are required.

BMP C162: Scheduling

Purpose

Sequencing a construction project reduces the amount and duration of soil exposed to erosion by wind, rain, runoff, and vehicle tracking.

Conditions of Use

The construction sequence schedule is an orderly listing of all major land-disturbing activities together with the necessary erosion and sedimentation control measures planned for the project. This type of schedule guides the contractor on work to be done before other work is started so that serious erosion and sedimentation problems can be avoided.

Following a specified work schedule that coordinates the timing of land-disturbing activities and the installation of control measures is perhaps the most cost-effective way of controlling erosion during construction. The removal of ground cover leaves a site vulnerable to erosion. Construction sequencing that limits land clearing, provides timely installation of erosion and sedimentation controls, and restores protective cover quickly can significantly reduce the erosion potential of a site.

Design Considerations

- Minimize construction during rainy periods.
- Schedule projects to disturb only small portions of the site at any one time. Complete grading as soon as possible. Immediately stabilize the disturbed portion before grading the next portion. Practice staged seeding in order to revegetate cut and fill slopes as the work progresses.

II-3.3 Construction Runoff BMPs

BMP C205: Subsurface Drains

Purpose

The purpose of subsurface drains is to intercept, collect, and convey ground water to a satisfactory outlet, using a perforated pipe or other conduit below the ground surface. Subsurface drains are also known as “french drains.” The perforated pipe provides a dewatering mechanism to drain excessively wet soils, provide a stable base for construction, improve stability of structures with shallow foundations, or to reduce hydrostatic pressure to improve slope stability.

Conditions of Use

Use subsurface drains when excessive water must be removed from the soil. The soil permeability, depth to water table, and impervious layers are all factors which may govern the use of subsurface drains.

Design and Installation Specifications

Subsurface Drain Type: Relief Drains

Relief drains are used to lower the water table in large, relatively flat areas, improve the growth of vegetation, or to remove surface water.

Relief drains are installed along a slope and drain in the direction of the slope.

Relief drains can be installed in a grid pattern, a herringbone pattern, or a random pattern.

Subsurface Drain Type: Interceptor Drains

Interceptor drains are used to remove excess ground water from a slope, stabilize steep slopes, and lower the water table immediately below a slope to prevent the soil from becoming saturated.

Interceptor drains are installed perpendicular to a slope and drain to the side of the slope.

Interceptor drains usually consist of a single pipe or series of single pipes instead of a patterned layout.

Subsurface Drain Depth and Spacing

- The depth of a subsurface drain is determined primarily by the depth to which the water table is to be lowered or the depth to a confining layer. For practical reasons, the maximum depth is usually limited to 6 feet, with a minimum cover of 2 feet to protect the conduit.
- The soil should have depth and sufficient permeability to permit installation of an effective drainage system at a depth of 2 to 6 feet.

Subsurface Drain Sizing and Placement

- The quantity and quality of discharge needs to be accounted for in the receiving stream (additional detention may be required).
- The size of a subsurface drain is determined by first calculating the maximum rate of ground water flow to be intercepted, and then choosing a subsurface drain pipe (or pipes) with enough capacity to convey that flow. Therefore, it is good practice to make complete subsurface investigations, including hydraulic conductivity of the soil, before designing a subsurface drainage system.
- Size subsurface drains to carry the required capacity without pressure flow. Minimum diameter for a subsurface drain is 4 inches.
- The minimum velocity in the pipe required to prevent silting is 1.4 ft/sec. Grade the subsurface drain to achieve this velocity at a minimum. The maximum allowable velocity using a sand-gravel filter or envelope is 9 ft/sec.
- Filter material and fabric shall be used around all drains for proper bedding and filtration of fine materials. Envelopes and filters should surround the drain to a minimum of 3-inch thickness.
- The trench shall be constructed on a continuous grade with no reverse grades or low spots.
- Soft or yielding soils under the subsurface drain shall be stabilized with gravel or other suitable material.
- Backfilling shall be done immediately after placement of the pipe. No sections of pipe shall remain uncovered overnight or during a rainstorm. Backfill material shall be placed in the trench in such a manner that the drain pipe is not displaced or damaged.
- Do not install permanent drains near trees to avoid the tree roots that tend to clog the line. Use solid pipe with watertight connections where it is necessary to pass a subsurface drainage system through a stand of trees.

Subsurface Drain Outlets

- An adequate outlet for the subsurface drain must be available either by gravity or by pumping.
- The outlet of the subsurface drain shall empty into a sediment trapping BMP through a catch basin. If free of sediment, it can then empty into a receiving channel, swale, or stable vegetated area adequately protected from erosion and undermining.
- Ensure that the outlet of a subsurface drain empties into a channel or other watercourse above the normal water level.
- Secure an animal guard to the outlet end of the pipe to keep out rodents.
- Use outlet pipe of corrugated metal, cast iron, or heavy-duty plastic without perforations and at least 10 feet long. Do not use an envelope or filter material around the outlet pipe, and bury at least two-thirds of the pipe length.

- When outlet velocities exceed those allowable for the receiving stream, outlet protection must be provided.

Maintenance Standards

Subsurface drains shall be checked periodically to ensure that they are free-flowing and not clogged with sediment or roots.

- The outlet shall be kept clean and free of debris.
- Surface inlets shall be kept open and free of sediment and other debris.
- Trees located too close to a subsurface drain often clog the system with their roots. If a drain becomes clogged, relocate the drain or remove the trees as a last resort. Drain placement should be planned to minimize this problem.
- Where drains are crossed by heavy vehicles, the line shall be checked to ensure that it is not crushed.

BMP C220: Inlet Protection

Purpose

Inlet protection prevents coarse sediment from entering drainage systems prior to permanent stabilization of the disturbed area.

Conditions of Use

Use inlet protection at inlets that are operational before permanent stabilization of the disturbed areas that contribute runoff to the inlet. Provide protection for all storm drain inlets downslope and within 500 feet of a disturbed or construction area, unless those inlets are preceded by a sediment trapping BMP.

Also consider inlet protection for lawn and yard drains on new home construction. These small and numerous drains coupled with lack of gutters can add significant amounts of sediment into the roof drain system. If possible, delay installing lawn and yard drains until just before landscaping, or cap these drains to prevent sediment from entering the system until completion of landscaping. Provide 18-inches of sod around each finished lawn and yard drain.

[Table II-3.10: Storm Drain Inlet Protection](#) lists several options for inlet protection. All of the methods for inlet protection tend to plug and require a high frequency of maintenance. Limit contributing drainage areas for an individual inlet to one acre or less. If possible, provide emergency overflows with additional end-of-pipe treatment where stormwater ponding would cause a hazard.

Table II-3.10: Storm Drain Inlet Protection

Type of Inlet Protection	Emergency Overflow	Applicable for Paved/ Earthen Surfaces	Conditions of Use
Drop Inlet Protection			
Excavated drop inlet protection	Yes, temporary flooding may occur	Earthen	Applicable for heavy flows. Easy to maintain. Large area requirement: 30'x30'/acre
Block and gravel drop inlet protection	Yes	Paved or Earthen	Applicable for heavy concentrated flows. Will not pond.
Gravel and wire drop inlet protection	No	Paved or Earthen	Applicable for heavy concentrated flows. Will pond. Can withstand traffic.
Catch basin filters	Yes	Paved or Earthen	Frequent maintenance required.
Curb Inlet Protection			
Curb inlet protection with wooden weir	Small capacity overflow	Paved	Used for sturdy, more compact installation.
Block and gravel curb inlet protection	Yes	Paved	Sturdy, but limited filtration.
Culvert Inlet Protection			
Culvert inlet sediment trap	N/A	N/A	18 month expected life.

Design and Installation Specifications

Excavated Drop Inlet Protection

Excavated drop inlet protection consists of an excavated impoundment around the storm drain inlet. Sediment settles out of the stormwater prior to entering the storm drain. Design and installation specifications for excavated drop inlet protection include:

- Provide a depth of 1-2 ft as measured from the crest of the inlet structure.
- Slope sides of excavation should be no steeper than 2H:1V.
- Minimum volume of excavation is 35 cubic yards.
- Shape the excavation to fit the site, with the longest dimension oriented toward the longest inflow area.
- Install provisions for draining to prevent standing water.
- Clear the area of all debris.

- Grade the approach to the inlet uniformly.
- Drill weep holes into the side of the inlet.
- Protect weep holes with screen wire and washed aggregate.
- Seal weep holes when removing structure and stabilizing area.
- Build a temporary dike, if necessary, to the down slope side of the structure to prevent bypass flow.

Block and Gravel Filter

A block and gravel filter is a barrier formed around the inlet with standard concrete blocks and gravel. See [Figure II-3.17: Block and Gravel Filter](#). Design and installation specifications for block gravel filters include:

- Provide a height of 1 to 2 feet above the inlet.
- Recess the first row of blocks 2-inches into the ground for stability.
- Support subsequent courses by placing a pressure treated wood 2x4 through the block opening.
- Do not use mortar.
- Lay some blocks in the bottom row on their side to allow for dewatering the pool.
- Place hardware cloth or comparable wire mesh with ½-inch openings over all block openings.
- Place gravel to just below the top of blocks on slopes of 2H:1V or flatter.
- An alternative design is a gravel berm surrounding the inlet, as follows:
 - Provide a slope of 3H:1V on the upstream side of the berm.
 - Provide a slope of 2H:1V on the downstream side of the berm.
 - Provide a 1-foot wide level stone area between the gravel berm and the inlet.
 - Use stones 3 inches in diameter or larger on the upstream slope of the berm.
 - Use gravel ½- to ¾-inch at a minimum thickness of 1-foot on the downstream slope of the berm.

Figure II-3.17: Block and Gravel Filter

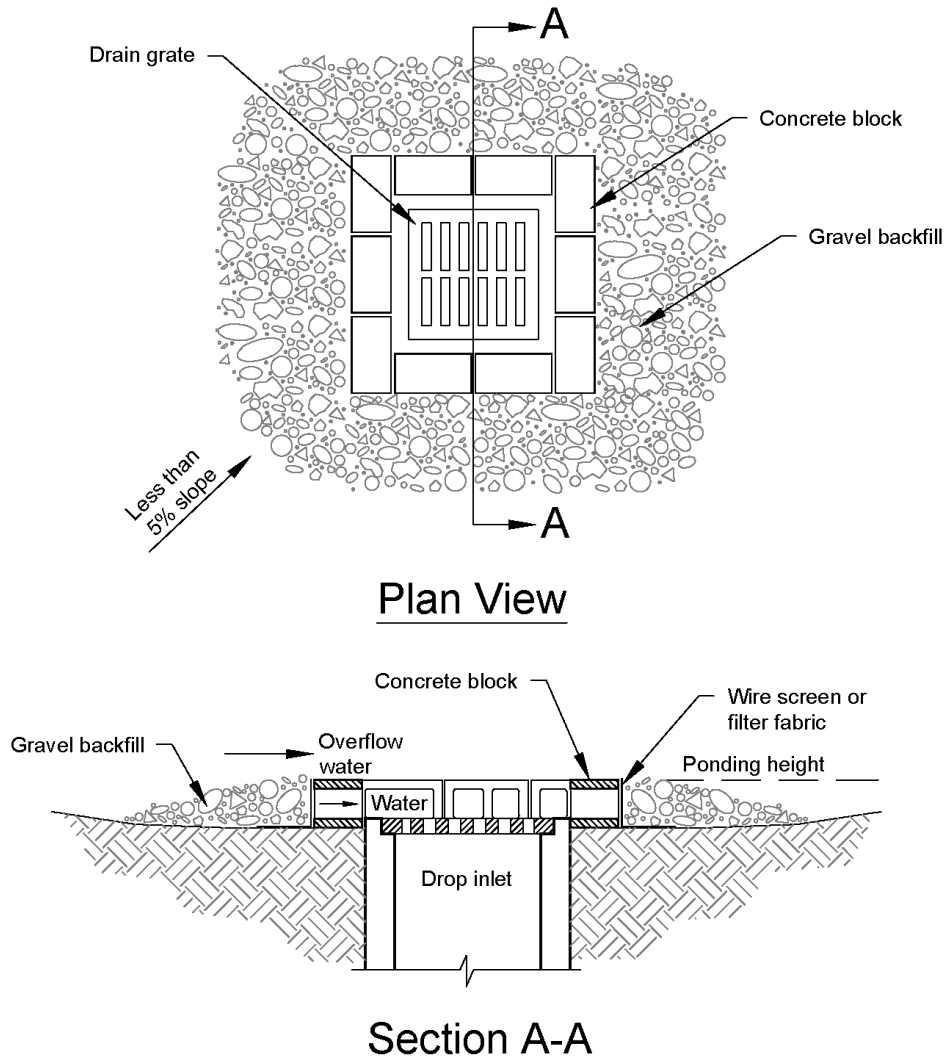

Notes:

1. Drop inlet sediment barriers are to be used for small, nearly level drainage areas. (less than 5%)
2. Excavate a basin of sufficient size adjacent to the drop inlet.
3. The top of the structure (ponding height) must be well below the ground elevation downslope to prevent runoff from bypassing the inlet. A temporary dike may be necessary on the downslope side of the structure.

NOT TO SCALE



Block and Gravel Filter

Revised June 2016

Please see <http://www.ecy.wa.gov/copyright.html> for copyright notice including permissions, limitation of liability, and disclaimer.

Gravel and Wire Mesh Filter

Gravel and wire mesh filters are gravel barriers placed over the top of the inlet. This method does not provide an overflow. Design and installation specifications for gravel and wire mesh filters include:

- Use a hardware cloth or comparable wire mesh with ½-inch openings.
 - Place wire mesh over the drop inlet so that the wire extends a minimum of 1-foot beyond each side of the inlet structure.
 - Overlap the strips if more than one strip of mesh is necessary.
- Place coarse aggregate over the wire mesh.
 - Provide at least a 12-inch depth of aggregate over the entire inlet opening and extend at least 18-inches on all sides.

Catch Basin Filters

Catch basin filters are designed by manufacturers for construction sites. The limited sediment storage capacity increases the amount of inspection and maintenance required, which may be daily for heavy sediment loads. To reduce maintenance requirements, combine a catch basin filter with another type of inlet protection. This type of inlet protection provides flow bypass without overflow and therefore may be a better method for inlets located along active rights-of-way. Design and installation specifications for catch basin filters include:

- Provides 5 cubic feet of storage.
- Requires dewatering provisions.
- Provides a high-flow bypass that will not clog under normal use at a construction site.
- Insert the catch basin filter in the catch basin just below the grating.

Curb Inlet Protection with Wooden Weir

Curb inlet protection with wooden weir is an option that consists of a barrier formed around a curb inlet with a wooden frame and gravel. Design and installation specifications for curb inlet protection with wooden weirs include:

- Use wire mesh with ½-inch openings.
- Use extra strength filter cloth.
- Construct a frame.
- Attach the wire and filter fabric to the frame.
- Pile coarse washed aggregate against the wire and fabric.
- Place weight on the frame anchors.

Block and Gravel Curb Inlet Protection

Block and gravel curb inlet protection is a barrier formed around a curb inlet with concrete blocks and gravel. See [Figure II-3.18: Block and Gravel Curb Inlet Protection](#). Design and installation specifications for block and gravel curb inlet protection include:

- Use wire mesh with ½-inch openings.
- Place two concrete blocks on their sides abutting the curb at either side of the inlet opening. These are spacer blocks.
- Place a 2x4 stud through the outer holes of each spacer block to align the front blocks.
- Place blocks on their sides across the front of the inlet and abutting the spacer blocks.
- Place wire mesh over the outside vertical face.
- Pile coarse aggregate against the wire to the top of the barrier.

Figure II-3.18: Block and Gravel Curb Inlet Protection

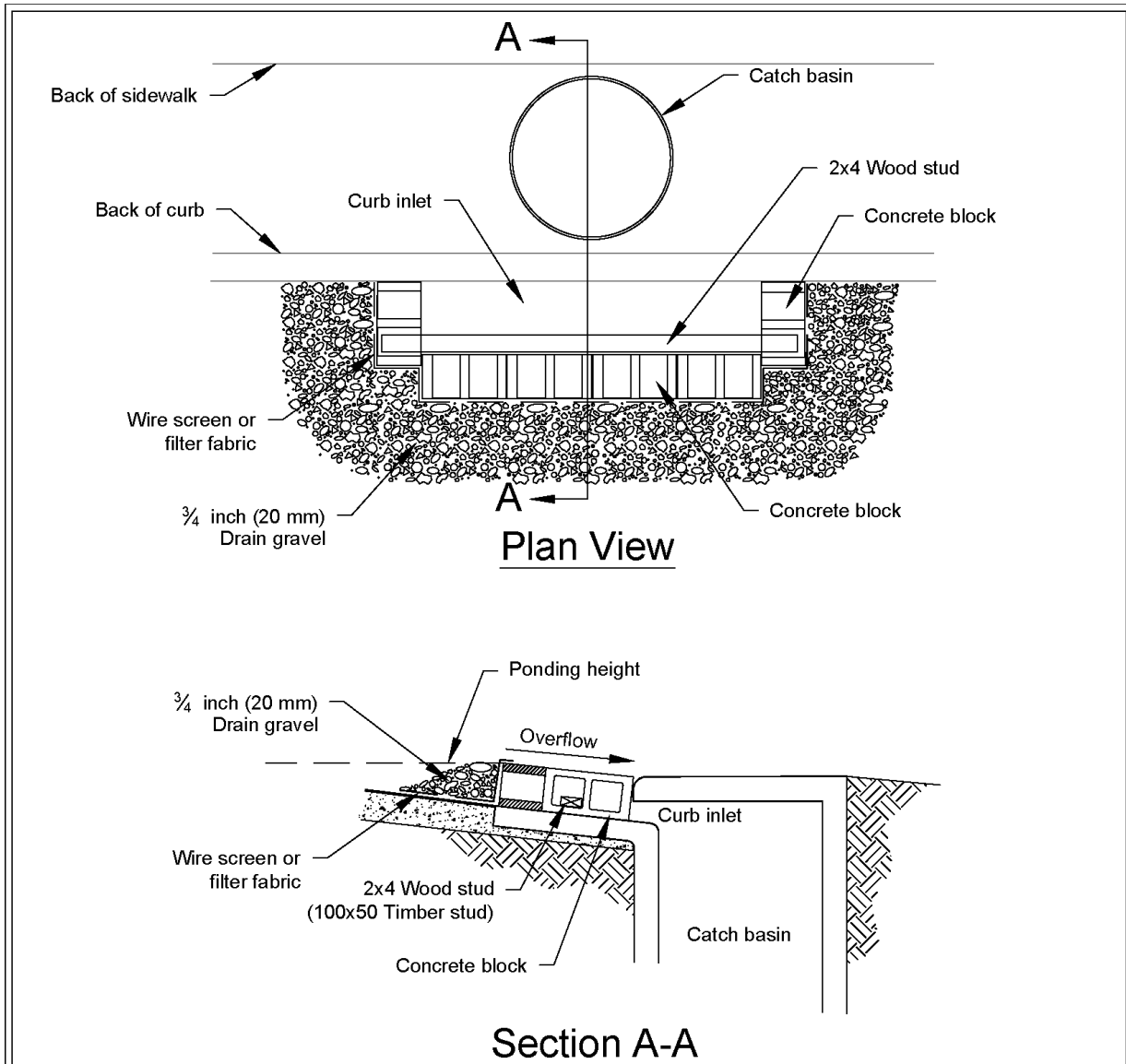

Notes:

1. Use block and gravel type sediment barrier when curb inlet is located in gently sloping street segment, where water can pond and allow sediment to separate from runoff.
2. Barrier shall allow for overflow from severe storm event.
3. Inspect barriers and remove sediment after each storm event. Sediment and gravel must be removed from the traveled way immediately.

NOT TO SCALE



Block and Gravel Curb Inlet Protection

Revised June 2016

Please see <http://www.ecy.wa.gov/copyright.html> for copyright notice including permissions, limitation of liability, and disclaimer.

Curb and Gutter Sediment Barrier

Curb and gutter sediment barrier is a sandbag or rock berm (riprap and aggregate) 3 feet high and 3 feet wide in a horseshoe shape. See [Figure II-3.19: Curb and Gutter Barrier](#). Design and installation specifications for curb and gutter sediment barrier include:

- Construct a horseshoe shaped berm, faced with coarse aggregate if using riprap, 3 feet high and 3 feet wide, at least 2 feet from the inlet.
- Construct a horseshoe shaped sedimentation trap on the upstream side of the berm. Size the trap to sediment trap standards for protecting a culvert inlet.

Figure II-3.19: Curb and Gutter Barrier

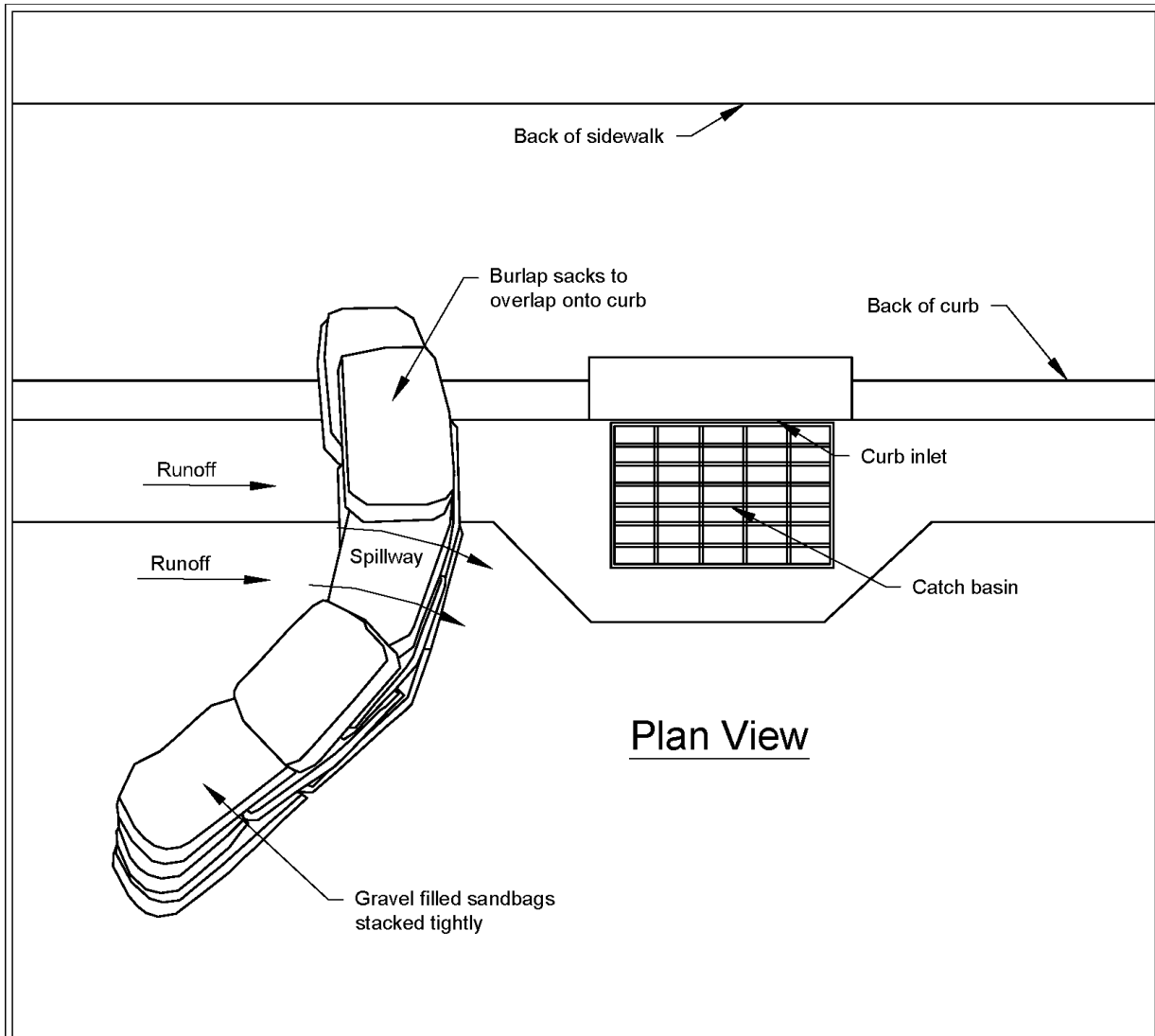

Plan View

Notes:

1. Place curb type sediment barriers on gently sloping street segments, where water can pond and allow sediment to separate from runoff.
2. Sandbags of either burlap or woven 'geotextile' fabric, are filled with gravel, layered and packed tightly.
3. Leave a one sandbag gap in the top row to provide a spillway for overflow.
4. Inspect barriers and remove sediment after each storm event. Sediment and gravel must be removed from the traveled way immediately.

NOT TO SCALE



Curb and Gutter Barrier

Revised June 2016

Please see <http://www.ecy.wa.gov/copyright.html> for copyright notice including permissions, limitation of liability, and disclaimer.

Maintenance Standards

- Inspect all forms of inlet protection frequently, especially after storm events. Clean and replace clogged catch basin filters. For rock and gravel filters, pull away the rocks from the inlet and clean or replace. An alternative approach would be to use the clogged rock as fill and put fresh rock around the inlet.
- Do not wash sediment into storm drains while cleaning. Spread all excavated material evenly over the surrounding land area or stockpile and stabilize as appropriate.

Approved as Functionally Equivalent

Ecology has approved products as able to meet the requirements of this BMP. The products did not pass through the Technology Assessment Protocol – Ecology (TAPE) process. Local jurisdictions may choose not to accept these products, or may require additional testing prior to consideration for local use. Products that Ecology has approved as functionally equivalent are available for review on Ecology's website at:

<https://ecology.wa.gov/Regulations-Permits/Guidance-technical-assistance/Stormwater-permittee-guidance-resources/Emerging-stormwater-treatment-technologies>

BMP C233: Silt Fence

Purpose

Silt fence reduces the transport of coarse sediment from a construction site by providing a temporary physical barrier to sediment and reducing the runoff velocities of overland flow.

Conditions of Use

Silt fence may be used downslope of all disturbed areas.

- Silt fence shall prevent sediment carried by runoff from going beneath, through, or over the top of the silt fence, but shall allow the water to pass through the fence.
- Silt fence is not intended to treat concentrated flows, nor is it intended to treat substantial amounts of overland flow. Convey any concentrated flows through the drainage system to a sediment trapping BMP.
- Do not construct silt fences in streams or use in V-shaped ditches. Silt fences do not provide an adequate method of silt control for anything deeper than sheet or overland flow.

Figure II-3.22: Silt Fence

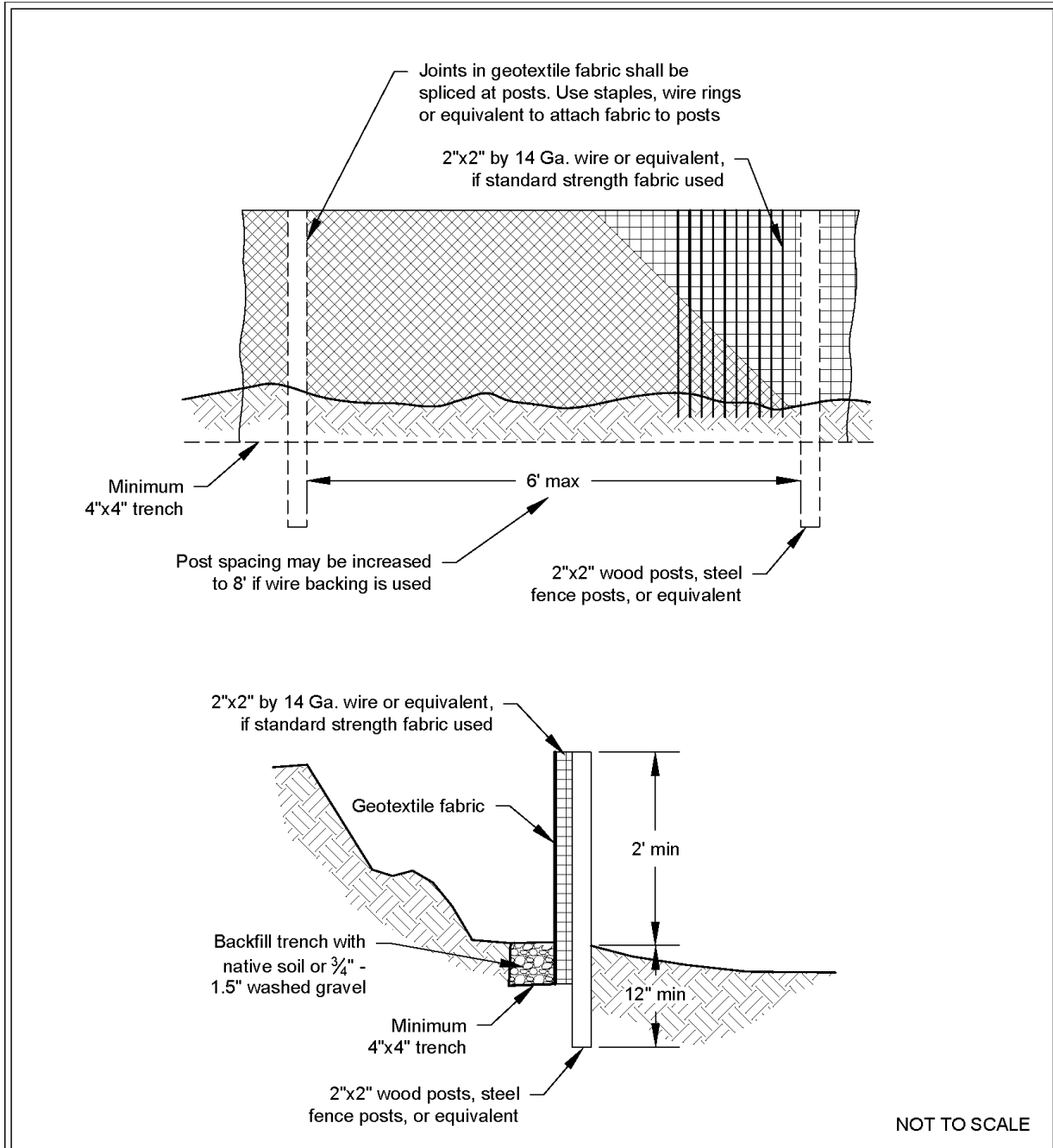

Silt Fence

Revised July 2017

Please see <http://www.ecy.wa.gov/copyright.html> for copyright notice including permissions, limitation of liability, and disclaimer.

Design and Installation Specifications

- Use in combination with other construction stormwater BMPs.
- Maximum slope steepness (perpendicular to the silt fence line) 1H:1V.
- Maximum sheet or overland flow path length to the silt fence of 100 feet.
- Do not allow flows greater than 0.5 cfs.
- Use geotextile fabric that meets the following standards. All geotextile properties listed below are minimum average roll values (i.e., the test result for any sampled roll in a lot shall meet or exceed the values shown in [Table II-3.11: Geotextile Fabric Standards for Silt Fence](#)):

Table II-3.11: Geotextile Fabric Standards for Silt Fence

Geotextile Property	Minimum Average Roll Value
Polymeric Mesh AOS (ASTM D4751)	0.60 mm maximum for slit film woven (#30 sieve). 0.30 mm maximum for all other geotextile types (#50 sieve). 0.15 mm minimum for all fabric types (#100 sieve).
Water Permittivity (ASTM D4491)	0.02 sec ⁻¹ minimum
Grab Tensile Strength (ASTM D4632)	180 lbs. Minimum for extra strength fabric. 100 lbs minimum for standard strength fabric.
Grab Tensile Strength (ASTM D4632)	30% maximum
Ultraviolet Resistance (ASTM D4355)	70% minimum

- Support standard strength geotextiles with wire mesh, chicken wire, 2-inch x 2-inch wire, safety fence, or jute mesh to increase the strength of the geotextile. Silt fence materials are available that have synthetic mesh backing attached.
- Silt fence material shall contain ultraviolet ray inhibitors and stabilizers to provide a minimum of six months of expected usable construction life at a temperature range of 0°F to 120°F.
- One-hundred percent biodegradable silt fence is available that is strong, long lasting, and can be left in place after the project is completed, if permitted by the local jurisdiction.
- Refer to [Figure II-3.22: Silt Fence](#) for standard silt fence details. Include the following Standard Notes for silt fence on construction plans and specifications:
 1. The Contractor shall install and maintain temporary silt fences at the locations shown in the Plans.
 2. Construct silt fences in areas of clearing, grading, or drainage prior to starting those activities.

3. The silt fence shall have a 2-foot min. and a 2½-foot max. height above the original ground surface.
4. The geotextile fabric shall be sewn together at the point of manufacture to form fabric lengths as required. Locate all sewn seams at support posts. Alternatively, two sections of silt fence can be overlapped, provided that the overlap is long enough and that the adjacent silt fence sections are close enough together to prevent silt laden water from escaping through the fence at the overlap.
5. Attach the geotextile fabric on the up-slope side of the posts and secure with staples, wire, or in accordance with the manufacturer's recommendations. Attach the geotextile fabric to the posts in a manner that reduces the potential for tearing.
6. Support the geotextile fabric with wire or plastic mesh, dependent on the properties of the geotextile selected for use. If wire or plastic mesh is used, fasten the mesh securely to the up-slope side of the posts with the geotextile fabric up-slope of the mesh.
7. Mesh support, if used, shall consist of steel wire with a maximum mesh spacing of 2-inches, or a prefabricated polymeric mesh. The strength of the wire or polymeric mesh shall be equivalent to or greater than 180 lbs. grab tensile strength. The polymeric mesh must be as resistant to the same level of ultraviolet radiation as the geotextile fabric it supports.
8. Bury the bottom of the geotextile fabric 4-inches min. below the ground surface. Backfill and tamp soil in place over the buried portion of the geotextile fabric, so that no flow can pass beneath the silt fence and scouring cannot occur. When wire or polymeric back-up support mesh is used, the wire or polymeric mesh shall extend into the ground 3-inches min.
9. Drive or place the silt fence posts into the ground 18-inches min. A 12-inch min. depth is allowed if topsoil or other soft subgrade soil is not present and 18-inches cannot be reached. Increase fence post min. depths by 6 inches if the fence is located on slopes of 3H:1V or steeper and the slope is perpendicular to the fence. If required post depths cannot be obtained, the posts shall be adequately secured by bracing or guying to prevent overturning of the fence due to sediment loading.
10. Use wood, steel or equivalent posts. The spacing of the support posts shall be a maximum of 6-feet. Posts shall consist of either:
 - Wood with minimum dimensions of 2 inches by 2 inches by 3 feet. Wood shall be free of defects such as knots, splits, or gouges.
 - No. 6 steel rebar or larger.
 - ASTM A 120 steel pipe with a minimum diameter of 1-inch.
 - U, T, L, or C shape steel posts with a minimum weight of 1.35 lbs./ft.
 - Other steel posts having equivalent strength and bending resistance to the post sizes listed above.
11. Locate silt fences on contour as much as possible, except at the ends of the fence,

where the fence shall be turned uphill such that the silt fence captures the runoff water and prevents water from flowing around the end of the fence.

12. If the fence must cross contours, with the exception of the ends of the fence, place check dams perpendicular to the back of the fence to minimize concentrated flow and erosion. The slope of the fence line where contours must be crossed shall not be steeper than 3H:1V.
 - Check dams shall be approximately 1-foot deep at the back of the fence. Check dams shall be continued perpendicular to the fence at the same elevation until the top of the check dam intercepts the ground surface behind the fence.
 - Check dams shall consist of crushed surfacing base course, gravel backfill for walls, or shoulder ballast. Check dams shall be located every 10 feet along the fence where the fence must cross contours.
- Refer to [Figure II-3.23: Silt Fence Installation by Slicing Method](#) for slicing method details. The following are specifications for silt fence installation using the slicing method:
 1. The base of both end posts must be at least 2- to 4-inches above the top of the geotextile fabric on the middle posts for ditch checks to drain properly. Use a hand level or string level, if necessary, to mark base points before installation.
 2. Install posts 3- to 4-feet apart in critical retention areas and 6- to 7-feet apart in standard applications.
 3. Install posts 24-inches deep on the downstream side of the silt fence, and as close as possible to the geotextile fabric, enabling posts to support the geotextile fabric from upstream water pressure.
 4. Install posts with the nipples facing away from the geotextile fabric.
 5. Attach the geotextile fabric to each post with three ties, all spaced within the top 8-inches of the fabric. Attach each tie diagonally 45 degrees through the fabric, with each puncture at least 1-inch vertically apart. Each tie should be positioned to hang on a post nipple when tightening to prevent sagging.
 6. Wrap approximately 6-inches of the geotextile fabric around the end posts and secure with 3 ties.
 7. No more than 24-inches of a 36-inch geotextile fabric is allowed above ground level.
 8. Compact the soil immediately next to the geotextile fabric with the front wheel of the tractor, skid steer, or roller exerting at least 60 pounds per square inch. Compact the upstream side first and then each side twice for a total of four trips. Check and correct the silt fence installation for any deviation before compaction. Use a flat-bladed shovel to tuck the fabric deeper into the ground if necessary.

Figure II-3.23: Silt Fence Installation by Slicing Method

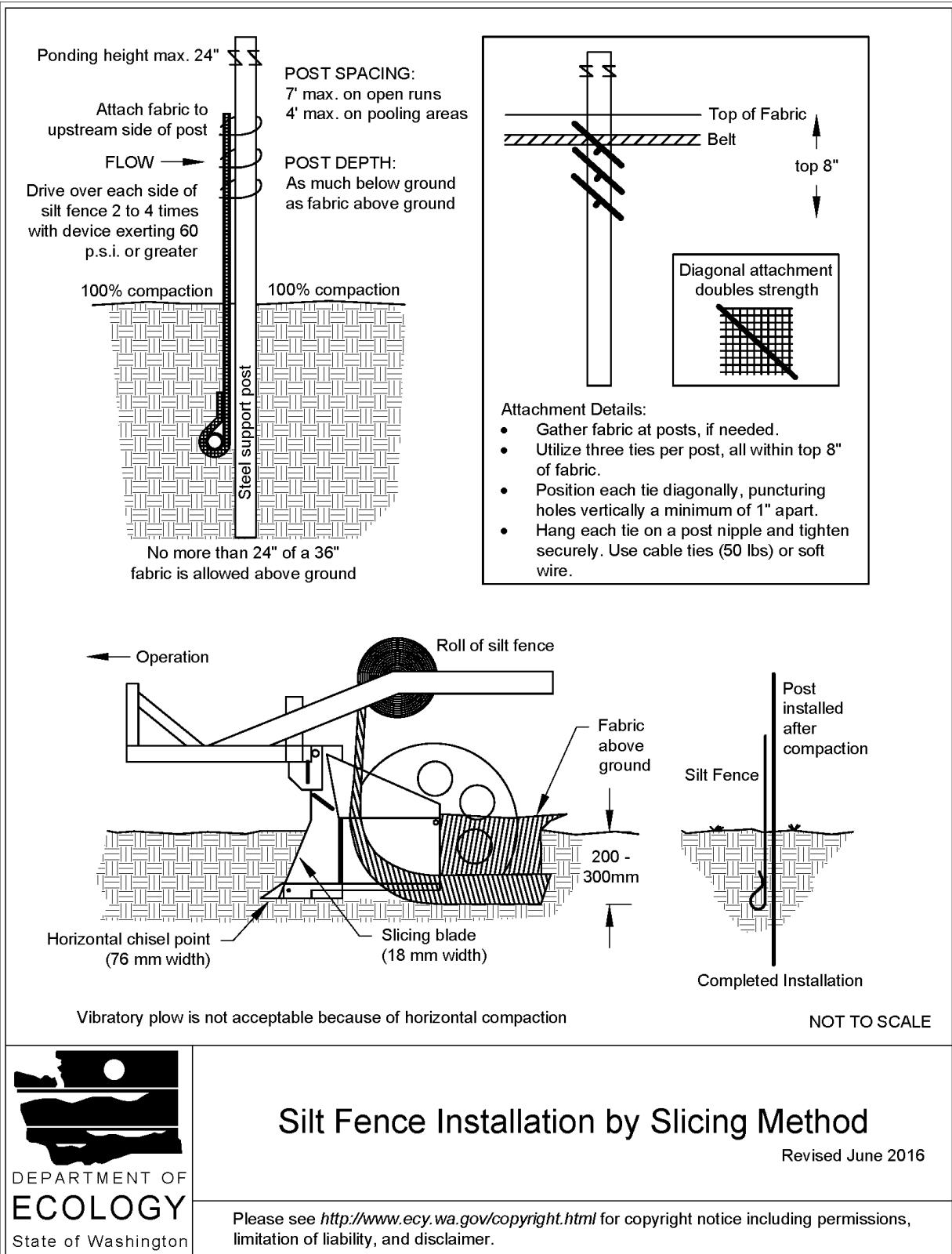

Maintenance Standards

- Repair any damage immediately.
- Intercept and convey all evident concentrated flows uphill of the silt fence to a sediment trapping BMP.
- Check the uphill side of the silt fence for signs of the fence clogging and acting as a barrier to flow and then causing channelization of flows parallel to the fence. If this occurs, replace the fence and remove the trapped sediment.
- Remove sediment deposits when the deposit reaches approximately one-third the height of the silt fence, or install a second silt fence.
- Replace geotextile fabric that has deteriorated due to ultraviolet breakdown.

BMP C234: Vegetated Strip

Purpose

Vegetated strips reduce the transport of coarse sediment from a construction site by providing a physical barrier to sediment and reducing the runoff velocities of overland flow.

Conditions of Use

- Vegetated strips may be used downslope of all disturbed areas.
- Vegetated strips are not intended to treat concentrated flows, nor are they intended to treat substantial amounts of overland flow. Any concentrated flows must be conveyed through the drainage system to [BMP C241: Sediment Pond \(Temporary\)](#) or other sediment trapping BMP. The only circumstance in which overland flow can be treated solely by a vegetated strip, rather than by a sediment trapping BMP, is when the following criteria are met (see [Table II-3.12: Contributing Drainage Area for Vegetated Strips](#)):

Table II-3.12: Contributing Drainage Area for Vegetated Strips

Average Contributing Area Slope	Average Contributing Area Percent Slope	Max Contributing area Flowpath Length
1.5H : 1V or flatter	67% or flatter	100 feet
2H : 1V or flatter	50% or flatter	115 feet
4H : 1V or flatter	25% or flatter	150 feet
6H : 1V or flatter	16.7% or flatter	200 feet
10H : 1V or flatter	10% or flatter	250 feet

Design and Installation Specifications

- The vegetated strip shall consist of a continuous strip of dense vegetation with topsoil for a minimum of a 25-foot length along the flowpath. Grass-covered, landscaped areas are generally not adequate because the volume of sediment overwhelms the grass. Ideally, vegetated strips shall consist of undisturbed native growth with a well-developed soil that allows for infiltration of runoff.
- The slope within the vegetated strip shall not exceed 4H:1V.
- The uphill boundary of the vegetated strip shall be delineated with clearing limits.

Maintenance Standards

- Any areas damaged by erosion or construction activity shall be seeded immediately and protected by mulch.
- If more than 5 feet of the original vegetated strip width has had vegetation removed or is being eroded, sod must be installed.
- If there are indications that concentrated flows are traveling across the vegetated strip, storm-water runoff controls must be installed to reduce the flows entering the vegetated strip, or additional perimeter protection must be installed.

BMP C235: Wattles

Purpose

Wattles are temporary erosion and sediment control barriers consisting of straw, compost, or other material that is wrapped in netting made of natural plant fiber or similar encasing material. They reduce the velocity and can spread the flow of rill and sheet runoff, and can capture and retain sediment.

Conditions of Use

- Wattles shall consist of cylinders of plant material such as weed-free straw, coir, wood chips, excelsior, or wood fiber or shavings encased within netting made of natural plant fibers unaltered by synthetic materials.
- Use wattles:
 - In disturbed areas that require immediate erosion protection.
 - On exposed soils during the period of short construction delays, or over winter months.
 - On slopes requiring stabilization until permanent vegetation can be established.
- The material used dictates the effectiveness period of the wattle. Generally, wattles are effective for one to two seasons.

- Prevent rilling beneath wattles by entrenching and overlapping wattles to prevent water from passing between them.

Design Criteria

- See [Figure II-3.24: Wattles](#) for typical construction details.
- Wattles are typically 8 to 10 inches in diameter and 25 to 30 feet in length.
- Install wattles perpendicular to the flow direction and parallel to the slope contour.
- Place wattles in shallow trenches, staked along the contour of disturbed or newly constructed slopes. Dig narrow trenches across the slope (on contour) to a depth of 3- to 5-inches on clay soils and soils with gradual slopes. On loose soils, steep slopes, and areas with high rainfall, the trenches should be dug to a depth of 5- to 7- inches, or 1/2 to 2/3 of the thickness of the wattle.
- Start building trenches and installing wattles from the base of the slope and work up. Spread excavated material evenly along the uphill slope and compact it using hand tamping or other methods.
- Construct trenches at intervals of 10- to 25-feet depending on the steepness of the slope, soil type, and rainfall. The steeper the slope the closer together the trenches.
- Install the wattles snugly into the trenches and overlap the ends of adjacent wattles 12 inches behind one another.
- Install stakes at each end of the wattle, and at 4-foot centers along entire length of wattle.
- If required, install pilot holes for the stakes using a straight bar to drive holes through the wattle and into the soil.
- Wooden stakes should be approximately 0.75 x 0.75 x 24 inches min. Willow cuttings or 3/8-inch rebar can also be used for stakes.
- Stakes should be driven through the middle of the wattle, leaving 2 to 3 inches of the stake protruding above the wattle.

Figure II-3.24: Wattles

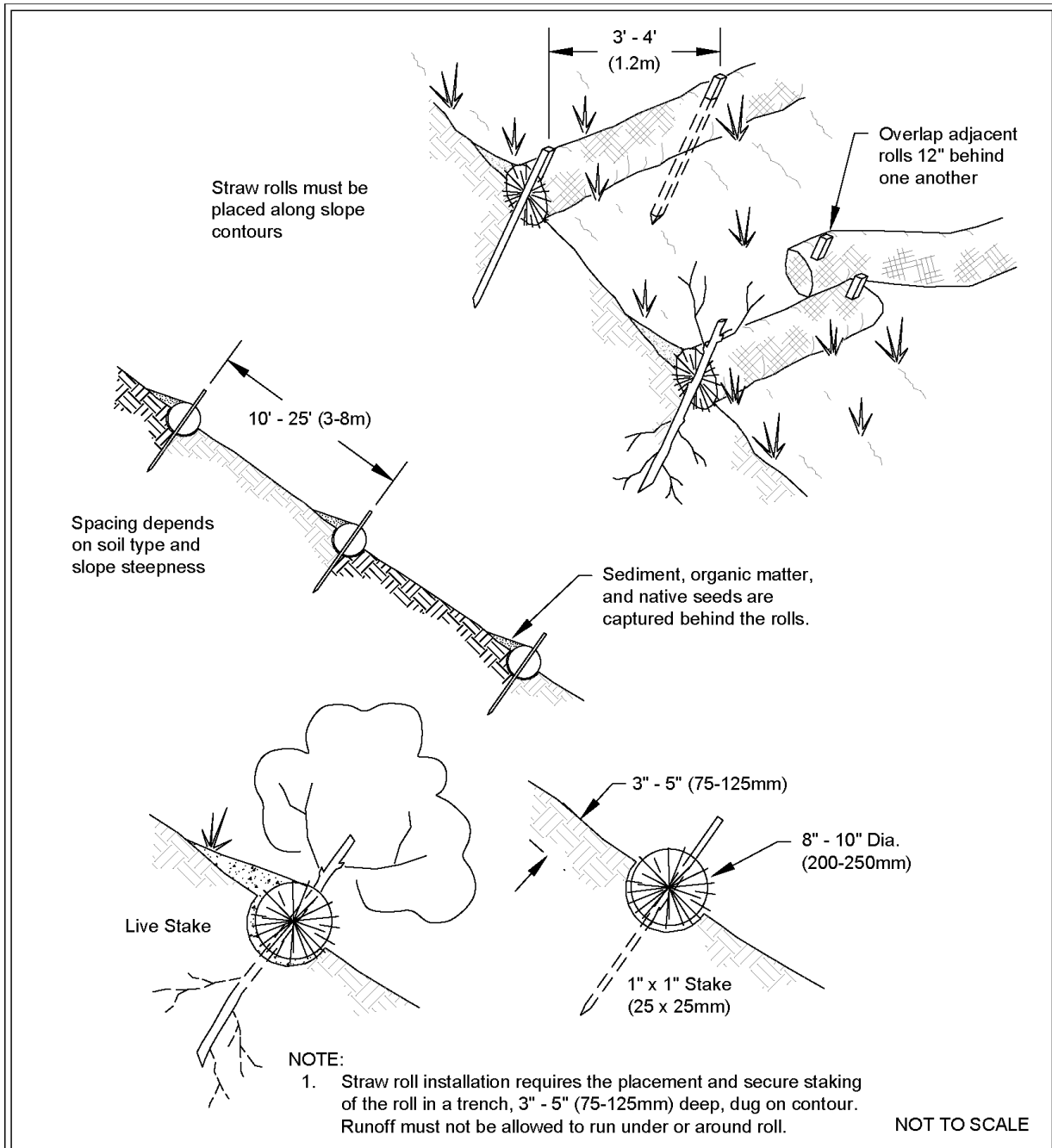

Wattles

Revised December 2016

Please see <http://www.ecy.wa.gov/copyright.html> for copyright notice including permissions, limitation of liability, and disclaimer.

Maintenance Standards

- Wattles may require maintenance to ensure they are in contact with soil and thoroughly entrenched, especially after significant rainfall on steep sandy soils.
- Inspect the slope after significant storms and repair any areas where wattles are not tightly abutted or water has scoured beneath the wattles.

Approved as Functionally Equivalent

Ecology has approved products as able to meet the requirements of this BMP. The products did not pass through the Technology Assessment Protocol – Ecology (TAPE) process. Local jurisdictions may choose not to accept these products, or may require additional testing prior to consideration for local use. Products that Ecology has approved as functionally equivalent are available for review on Ecology’s website at:

<https://ecology.wa.gov/Regulations-Permits/Guidance-technical-assistance/Stormwater-permittee-guidance-resources/Emerging-stormwater-treatment-technologies>

BMP C236: Vegetative Filtration

Purpose

Vegetative filtration as a BMP is used in conjunction with detention storage in the form of portable tanks or [BMP C241: Sediment Pond \(Temporary\)](#), [BMP C206: Level Spreader](#), and a pumping system with surface intake. Vegetative filtration improves turbidity levels of stormwater discharges by filtering runoff through existing vegetation where undisturbed forest floor duff layer or established lawn with thatch layer are present. Vegetative filtration can also be used to infiltrate dewatering waste from foundations, vaults, and trenches as long as runoff does not occur.

Conditions of Use

- For every five acres of disturbed soil use one acre of grass field, farm pasture, or wooded area. Reduce or increase this area depending on project size, ground water table height, and other site conditions.
- Wetlands shall not be used for vegetative filtration.
- Do not use this BMP in areas with a high ground water table, or in areas that will have a high seasonal ground water table during the use of this BMP.
- This BMP may be less effective on soils that prevent the infiltration of the water, such as hard till.
- Using other effective source control measures throughout a construction site will prevent the generation of additional highly turbid water and may reduce the time period or area need for this BMP.
- Stop distributing water into the vegetated filtration area if standing water or erosion results.

treatment pond prior to decanting. Compliance with the water quality standards is determined in the receiving water.

Operator Training

Each project site using chemical treatment must have a trained operator who is certified for operation of an Enhanced Chemical Treatment system. The operator must be trained and certified by an organization approved by Ecology. Organizations approved for operator training are found at the following website:

<https://ecology.wa.gov/Regulations-Permits/Guidance-technical-assistance/Stormwater-permittee-guidance-resources/Contaminated-water-on-construction-sites>

Sediment Removal and Disposal

- Sediment shall be removed from the untreated stormwater storage pond and treatment cells as necessary. Typically, sediment removal is required at least once during a wet season and at the decommissioning of the chemical treatment system. Sediment remaining in the cells between batches may enhance the settling process and reduce the required chemical dosage.
- Sediment that is known to be non-toxic may be incorporated into the site away from drainages.

BMP C251: Construction Stormwater Filtration

Purpose

Filtration removes sediment from runoff originating from disturbed areas of the site.

Conditions of Use

Traditional Construction Stormwater BMPs used to control soil erosion and sediment loss from construction sites may not be adequate to ensure compliance with the water quality standard for turbidity in the receiving water. Filtration may be used in conjunction with gravity settling to remove sediment as small as fine silt (0.5 µm). The reduction in turbidity will be dependent on the particle size distribution of the sediment in the stormwater. In some circumstances, sedimentation and filtration may achieve compliance with the water quality standard for turbidity.

The use of construction stormwater filtration does not require approval from Ecology as long as treatment chemicals are not used. Filtration in conjunction with [BMP C250: Construction Stormwater Chemical Treatment](#) requires testing under the Chemical Technology Assessment Protocol – Ecology (CTAPE) before it can be initiated. Approval from Ecology must be obtained at each site where chemical use is proposed prior to use. See <https://fortress.wa.gov/ecy/publications/SummaryPages/ecy070258.html> for a copy of the Request for Chemical Treatment form.

Design and Installation Specifications

Two types of filtration systems may be applied to construction stormwater treatment: rapid and slow.

Rapid filtration systems are the typical system used for water and wastewater treatment. They can achieve relatively high hydraulic flow rates, on the order of 2 to 20 gpm/sf, because they have automatic backwash systems to remove accumulated solids.

Slow filtration systems have very low hydraulic rates, on the order of 0.02 gpm/sf, because they do not have backwash systems. Slow filtration systems have generally been used as post construction BMPs to treat stormwater (see [V-6 Filtration BMPs](#)). Slow filtration is mechanically simple in comparison to rapid filtration, but requires a much larger filter area.

Filter Types and Efficiencies

Sand media filters are available with automatic backwashing features that can filter to 50 µm particle size. Screen or bag filters can filter down to 5 µm. Fiber wound filters can remove particles down to 0.5 µm. Filters should be sequenced from the largest to the smallest pore opening. Sediment removal efficiency will be related to particle size distribution in the stormwater.

Treatment Process and Description

Stormwater is collected at interception point(s) on the site and diverted to an untreated stormwater sediment pond or tank for removal of large sediment, and storage of the stormwater before it is treated by the filtration system. In a rapid filtration system, the untreated stormwater is pumped from the pond or tank through the filtration media. Slow filtration systems are designed using gravity to convey water from the pond or tank to and through the filtration media.

Sizing

Filtration treatment systems must be designed to control the velocity and peak volumetric flow rate that is discharged from the system and consequently the project site. See [Element 3: Control Flow Rates](#) for further details on this requirement.

The untreated stormwater storage pond or tank should be sized to hold 1.5 times the volume of runoff generated from the site during the 10-year, 24-hour storm event, minus the filtration treatment system flowrate for an 8-hour period. For a chitosan-enhanced sand filtration system, the filtration treatment system flowrate should be sized using a hydraulic loading rate between 6-8 gpm/ft². Other hydraulic loading rates may be more appropriate for other systems. Bypass should be provided around the filtration treatment system to accommodate extreme storm events. Runoff volume shall be calculated using the methods presented in [III-2.3 Single Event Hydrograph Method](#). Worst-case land cover conditions (i.e., producing the most runoff) should be used for analyses (in most cases, this would be the land cover conditions just prior to final landscaping).

If the filtration treatment system design does not allow you to discharge at the rates as required by [Element 3: Control Flow Rates](#), and if the site has a permanent Flow Control BMP that will serve the planned development, the discharge from the filtration treatment system may be directed to the permanent Flow Control BMP to comply with [Element 3: Control Flow Rates](#). In this case, all discharge (including water passing through the treatment system and stormwater bypassing the treatment

system) will be directed into the permanent Flow Control BMP. If site constraints make locating the untreated stormwater storage pond difficult, the permanent Flow Control BMP may be divided to serve as the untreated stormwater storage pond and the post-treatment temporary flow control pond. A berm or barrier must be used in this case so the untreated water does not mix with the treated water. Both untreated stormwater storage requirements, and adequate post-treatment flow control must be achieved. The designer must document in the Construction SWPPP how the permanent Flow Control BMP is able to attenuate the discharge from the site to meet the requirements of [Element 3: Control Flow Rates](#). If the design of the permanent Flow Control BMP was modified for temporary construction flow control purposes, the construction of the permanent Flow Control BMP must be finalized, as designed for its permanent function, at project completion.

Maintenance Standards

- Rapid sand filters typically have automatic backwash systems that are triggered by a pre-set pressure drop across the filter. If the backwash water volume is not large or substantially more turbid than the untreated stormwater stored in the holding pond or tank, backwash return to the untreated stormwater pond or tank may be appropriate. However, other means of treatment and disposal may be necessary.
- Screen, bag, and fiber filters must be cleaned and/or replaced when they become clogged.
- Sediment shall be removed from the storage and/or treatment ponds as necessary. Typically, sediment removal is required once or twice during a wet season and at the decommissioning of the ponds.
- Disposal of filtration equipment must comply with applicable local, state, and federal regulations.

Appendix D

WWHM Output

WWHM2012
PROJECT REPORT

General Model Information

Project Name: APL Revised 2024-02-07
Site Name:
Site Address:
City:
Report Date: 4/12/2024
Gage: 38 IN CENTRAL
Data Start: 10/01/1901
Data End: 09/30/2059
Timestep: 15 Minute
Precip Scale: 1.000
Version Date: 2019/09/13
Version: 4.2.17

POC Thresholds

Low Flow Threshold for POC1:	50 Percent of the 2 Year
High Flow Threshold for POC1:	50 Year

Landuse Basin Data

Predeveloped Land Use

Basin 1

Bypass:	No
GroundWater:	No
Pervious Land Use C, Forest, Flat	acre 0.85
Pervious Total	0.85
Impervious Land Use	acre
Impervious Total	0
Basin Total	0.85

Element Flows To:		
Surface	Interflow	Groundwater

Mitigated Land Use

Basin 1

Bypass: No

GroundWater: No

Pervious Land Use acre
C, Lawn, Flat 0.35

Pervious Total 0.35

Impervious Land Use acre
ROADS FLAT 0.24
ROOF TOPS FLAT 0.23
SIDEWALKS FLAT 0.03

Impervious Total 0.5

Basin Total 0.85

Element Flows To:

Surface	Interflow	Groundwater
Contech CMP 1	Contech CMP 1	

Analysis Results

POC 1

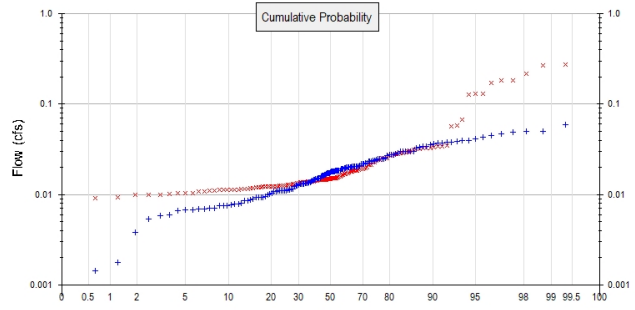
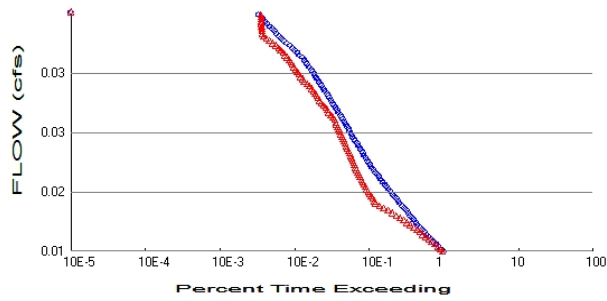

+ Predeveloped x Mitigated

Predeveloped Landuse Totals for POC #1

Total Pervious Area: 0.85
 Total Impervious Area: 0

Mitigated Landuse Totals for POC #1

Total Pervious Area: 0.35
 Total Impervious Area: 0.5

Flow Frequency Method: Log Pearson Type III 17B

Flow Frequency Return Periods for Predeveloped. POC #1

Return Period	Flow(cfs)
2 year	0.017912
5 year	0.027866
10 year	0.033274
25 year	0.038779
50 year	0.042051
100 year	0.044741

Flow Frequency Return Periods for Mitigated. POC #1

Return Period	Flow(cfs)
2 year	0.016719
5 year	0.031187
10 year	0.04659
25 year	0.075935
50 year	0.107739
100 year	0.151095

Annual Peaks

Annual Peaks for Predeveloped and Mitigated. POC #1

Year	Predeveloped	Mitigated
1902	0.013	0.014
1903	0.011	0.013
1904	0.018	0.017
1905	0.009	0.016
1906	0.004	0.011
1907	0.027	0.030
1908	0.020	0.015
1909	0.020	0.019
1910	0.028	0.023
1911	0.018	0.014

1912	0.060	0.028
1913	0.029	0.021
1914	0.007	0.015
1915	0.012	0.011
1916	0.018	0.014
1917	0.006	0.011
1918	0.019	0.017
1919	0.014	0.011
1920	0.018	0.015
1921	0.020	0.014
1922	0.020	0.024
1923	0.016	0.018
1924	0.008	0.013
1925	0.009	0.012
1926	0.017	0.014
1927	0.011	0.014
1928	0.014	0.012
1929	0.028	0.024
1930	0.018	0.012
1931	0.017	0.015
1932	0.013	0.014
1933	0.013	0.015
1934	0.038	0.033
1935	0.017	0.013
1936	0.015	0.012
1937	0.024	0.027
1938	0.015	0.014
1939	0.001	0.011
1940	0.016	0.017
1941	0.008	0.012
1942	0.025	0.029
1943	0.013	0.014
1944	0.023	0.273
1945	0.020	0.016
1946	0.011	0.013
1947	0.007	0.015
1948	0.039	0.056
1949	0.033	0.131
1950	0.009	0.012
1951	0.012	0.010
1952	0.050	0.219
1953	0.045	0.182
1954	0.016	0.014
1955	0.013	0.013
1956	0.007	0.009
1957	0.023	0.015
1958	0.048	0.129
1959	0.030	0.018
1960	0.008	0.012
1961	0.030	0.033
1962	0.016	0.018
1963	0.008	0.012
1964	0.009	0.015
1965	0.034	0.031
1966	0.009	0.013
1967	0.014	0.011
1968	0.015	0.020
1969	0.015	0.014

1970	0.023	0.019
1971	0.036	0.035
1972	0.024	0.024
1973	0.030	0.033
1974	0.016	0.014
1975	0.038	0.034
1976	0.020	0.018
1977	0.007	0.011
1978	0.034	0.030
1979	0.009	0.010
1980	0.019	0.012
1981	0.018	0.015
1982	0.008	0.011
1983	0.030	0.028
1984	0.012	0.015
1985	0.020	0.016
1986	0.018	0.014
1987	0.034	0.058
1988	0.022	0.015
1989	0.019	0.014
1990	0.022	0.021
1991	0.017	0.017
1992	0.025	0.017
1993	0.024	0.019
1994	0.036	0.033
1995	0.007	0.010
1996	0.039	0.032
1997	0.015	0.013
1998	0.018	0.020
1999	0.001	0.010
2000	0.014	0.013
2001	0.007	0.012
2002	0.025	0.015
2003	0.022	0.019
2004	0.020	0.015
2005	0.037	0.014
2006	0.011	0.010
2007	0.011	0.021
2008	0.019	0.014
2009	0.013	0.013
2010	0.011	0.028
2011	0.009	0.009
2012	0.013	0.032
2013	0.010	0.013
2014	0.008	0.010
2015	0.015	0.017
2016	0.006	0.010
2017	0.028	0.067
2018	0.050	0.182
2019	0.047	0.267
2020	0.015	0.013
2021	0.025	0.023
2022	0.010	0.012
2023	0.021	0.015
2024	0.039	0.027
2025	0.018	0.014
2026	0.030	0.025
2027	0.011	0.014

2028	0.009	0.011
2029	0.020	0.015
2030	0.038	0.034
2031	0.013	0.012
2032	0.007	0.009
2033	0.011	0.011
2034	0.011	0.016
2035	0.043	0.130
2036	0.022	0.018
2037	0.005	0.011
2038	0.018	0.028
2039	0.002	0.011
2040	0.010	0.015
2041	0.013	0.014
2042	0.042	0.171
2043	0.020	0.020
2044	0.027	0.025
2045	0.018	0.014
2046	0.022	0.015
2047	0.016	0.013
2048	0.021	0.019
2049	0.018	0.018
2050	0.013	0.015
2051	0.019	0.030
2052	0.011	0.018
2053	0.020	0.016
2054	0.025	0.025
2055	0.008	0.012
2056	0.009	0.012
2057	0.014	0.014
2058	0.017	0.013
2059	0.030	0.025

Ranked Annual Peaks

Ranked Annual Peaks for Predeveloped and Mitigated. POC #1

Rank	Predeveloped	Mitigated
1	0.0596	0.2735
2	0.0502	0.2669
3	0.0502	0.2194
4	0.0485	0.1818
5	0.0468	0.1817
6	0.0453	0.1708
7	0.0427	0.1310
8	0.0416	0.1299
9	0.0394	0.1288
10	0.0393	0.0667
11	0.0385	0.0580
12	0.0382	0.0563
13	0.0379	0.0348
14	0.0375	0.0344
15	0.0368	0.0343
16	0.0364	0.0331
17	0.0359	0.0327
18	0.0342	0.0325
19	0.0340	0.0325
20	0.0337	0.0323
21	0.0330	0.0317
22	0.0303	0.0314

23	0.0301	0.0301
24	0.0301	0.0298
25	0.0301	0.0296
26	0.0301	0.0287
27	0.0300	0.0285
28	0.0286	0.0284
29	0.0284	0.0281
30	0.0278	0.0275
31	0.0276	0.0270
32	0.0275	0.0268
33	0.0271	0.0254
34	0.0251	0.0253
35	0.0250	0.0253
36	0.0249	0.0251
37	0.0247	0.0243
38	0.0246	0.0240
39	0.0242	0.0237
40	0.0239	0.0228
41	0.0236	0.0228
42	0.0232	0.0215
43	0.0232	0.0213
44	0.0231	0.0213
45	0.0222	0.0198
46	0.0221	0.0197
47	0.0217	0.0196
48	0.0217	0.0194
49	0.0216	0.0190
50	0.0209	0.0190
51	0.0206	0.0186
52	0.0205	0.0185
53	0.0204	0.0184
54	0.0204	0.0183
55	0.0204	0.0183
56	0.0204	0.0182
57	0.0202	0.0181
58	0.0201	0.0181
59	0.0201	0.0178
60	0.0200	0.0173
61	0.0200	0.0171
62	0.0197	0.0170
63	0.0195	0.0170
64	0.0192	0.0169
65	0.0192	0.0165
66	0.0191	0.0164
67	0.0190	0.0163
68	0.0185	0.0158
69	0.0184	0.0157
70	0.0184	0.0156
71	0.0184	0.0153
72	0.0183	0.0153
73	0.0182	0.0152
74	0.0181	0.0152
75	0.0180	0.0151
76	0.0179	0.0151
77	0.0179	0.0151
78	0.0179	0.0150
79	0.0177	0.0150
80	0.0174	0.0149

81	0.0173	0.0148
82	0.0173	0.0148
83	0.0172	0.0148
84	0.0169	0.0147
85	0.0164	0.0146
86	0.0164	0.0146
87	0.0163	0.0145
88	0.0163	0.0145
89	0.0162	0.0145
90	0.0159	0.0145
91	0.0153	0.0144
92	0.0151	0.0144
93	0.0151	0.0144
94	0.0148	0.0143
95	0.0148	0.0143
96	0.0147	0.0143
97	0.0145	0.0142
98	0.0145	0.0140
99	0.0141	0.0140
100	0.0139	0.0140
101	0.0137	0.0140
102	0.0136	0.0139
103	0.0134	0.0138
104	0.0133	0.0138
105	0.0132	0.0137
106	0.0132	0.0137
107	0.0131	0.0137
108	0.0131	0.0136
109	0.0130	0.0135
110	0.0128	0.0135
111	0.0126	0.0133
112	0.0125	0.0131
113	0.0123	0.0130
114	0.0115	0.0130
115	0.0115	0.0128
116	0.0113	0.0128
117	0.0112	0.0127
118	0.0111	0.0127
119	0.0111	0.0126
120	0.0111	0.0126
121	0.0110	0.0126
122	0.0110	0.0126
123	0.0109	0.0124
124	0.0108	0.0124
125	0.0108	0.0122
126	0.0103	0.0122
127	0.0102	0.0122
128	0.0098	0.0122
129	0.0095	0.0122
130	0.0094	0.0121
131	0.0094	0.0121
132	0.0093	0.0121
133	0.0093	0.0120
134	0.0090	0.0117
135	0.0087	0.0117
136	0.0086	0.0115
137	0.0085	0.0115
138	0.0080	0.0114

139	0.0078	0.0114
140	0.0078	0.0114
141	0.0078	0.0114
142	0.0076	0.0114
143	0.0075	0.0114
144	0.0075	0.0113
145	0.0070	0.0110
146	0.0070	0.0109
147	0.0070	0.0107
148	0.0069	0.0107
149	0.0068	0.0103
150	0.0068	0.0103
151	0.0066	0.0103
152	0.0060	0.0102
153	0.0058	0.0099
154	0.0053	0.0099
155	0.0038	0.0099
156	0.0018	0.0094
157	0.0014	0.0091
158	0.0009	0.0089

Duration Flows

The Facility PASSED

Flow(cfs)	Predev	Mit	Percentage	Pass/Fail
0.0090	54276	53151	97	Pass
0.0093	50160	49257	98	Pass
0.0096	46570	45733	98	Pass
0.0100	43312	42038	97	Pass
0.0103	40287	38071	94	Pass
0.0106	37512	34603	92	Pass
0.0110	34925	31484	90	Pass
0.0113	32603	28747	88	Pass
0.0116	30315	26254	86	Pass
0.0120	28288	24149	85	Pass
0.0123	26459	21723	82	Pass
0.0126	24797	19518	78	Pass
0.0130	23318	17640	75	Pass
0.0133	21928	15939	72	Pass
0.0136	20653	14293	69	Pass
0.0140	19407	12665	65	Pass
0.0143	18293	11196	61	Pass
0.0146	17241	9850	57	Pass
0.0150	16160	8626	53	Pass
0.0153	15158	7551	49	Pass
0.0156	14271	6742	47	Pass
0.0160	13462	6426	47	Pass
0.0163	12659	6144	48	Pass
0.0166	11944	5861	49	Pass
0.0170	11252	5568	49	Pass
0.0173	10565	5325	50	Pass
0.0176	9983	5093	51	Pass
0.0180	9374	4870	51	Pass
0.0183	8853	4665	52	Pass
0.0187	8332	4492	53	Pass
0.0190	7861	4333	55	Pass
0.0193	7468	4172	55	Pass
0.0197	7030	4005	56	Pass
0.0200	6620	3870	58	Pass
0.0203	6271	3742	59	Pass
0.0207	5978	3625	60	Pass
0.0210	5701	3507	61	Pass
0.0213	5440	3404	62	Pass
0.0217	5200	3317	63	Pass
0.0220	4943	3231	65	Pass
0.0223	4706	3119	66	Pass
0.0227	4511	3002	66	Pass
0.0230	4339	2895	66	Pass
0.0233	4154	2788	67	Pass
0.0237	3958	2708	68	Pass
0.0240	3770	2628	69	Pass
0.0243	3580	2544	71	Pass
0.0247	3417	2475	72	Pass
0.0250	3260	2381	73	Pass
0.0253	3135	2291	73	Pass
0.0257	3026	2213	73	Pass
0.0260	2928	2146	73	Pass
0.0263	2815	2091	74	Pass

0.0267	2682	2020	75	Pass
0.0270	2556	1958	76	Pass
0.0273	2451	1891	77	Pass
0.0277	2361	1790	75	Pass
0.0280	2255	1684	74	Pass
0.0283	2142	1578	73	Pass
0.0287	2041	1503	73	Pass
0.0290	1952	1433	73	Pass
0.0293	1861	1349	72	Pass
0.0297	1778	1248	70	Pass
0.0300	1691	1184	70	Pass
0.0304	1618	1125	69	Pass
0.0307	1561	1088	69	Pass
0.0310	1483	1044	70	Pass
0.0314	1407	988	70	Pass
0.0317	1340	925	69	Pass
0.0320	1270	867	68	Pass
0.0324	1218	806	66	Pass
0.0327	1162	741	63	Pass
0.0330	1103	705	63	Pass
0.0334	1057	663	62	Pass
0.0337	1006	629	62	Pass
0.0340	964	602	62	Pass
0.0344	919	565	61	Pass
0.0347	872	539	61	Pass
0.0350	814	511	62	Pass
0.0354	774	493	63	Pass
0.0357	738	467	63	Pass
0.0360	694	439	63	Pass
0.0364	637	408	64	Pass
0.0367	601	387	64	Pass
0.0370	555	359	64	Pass
0.0374	517	339	65	Pass
0.0377	478	312	65	Pass
0.0380	434	280	64	Pass
0.0384	394	253	64	Pass
0.0387	363	232	63	Pass
0.0390	339	210	61	Pass
0.0394	310	202	65	Pass
0.0397	295	200	67	Pass
0.0400	273	200	73	Pass
0.0404	252	198	78	Pass
0.0407	237	197	83	Pass
0.0410	223	196	87	Pass
0.0414	206	196	95	Pass
0.0417	195	196	100	Pass
0.0421	179	194	108	Pass

Water Quality

Water Quality BMP Flow and Volume for POC #1

On-line facility volume: 0 acre-feet

On-line facility target flow: 0 cfs.

Adjusted for 15 min: 0 cfs.

Off-line facility target flow: 0 cfs.

Adjusted for 15 min: 0 cfs.

LID Report

LID Technique	Used for Treatment ?	Total Volume Needs Treatment (ac-ft)	Volume Through Facility (ac-ft)	Infiltration Volume (ac-ft)	Cumulative Volume Infiltration Credit	Percent Volume Infiltrated	Water Quality	Percent Water Quality Treated	Comment
Total Volume Infiltrated		0.00	0.00	0.00		0.00	0.00	0%	No Treat. Credit
Compliance with LID Standard 8% of 2-yr to 50% of 2-yr									Duration Analysis Result = Passed

Model Default Modifications

Total of 0 changes have been made.

PERLND Changes

No PERLND changes have been made.

IMPLND Changes

No IMPLND changes have been made.

Mitigated Schematic



Basin 1
0.85ac

SI



Contech
CMP 1

Disclaimer

Legal Notice

This program and accompanying documentation are provided 'as-is' without warranty of any kind. The entire risk regarding the performance and results of this program is assumed by End User. Clear Creek Solutions Inc. and the governmental licensee or sublicensees disclaim all warranties, either expressed or implied, including but not limited to implied warranties of program and accompanying documentation. In no event shall Clear Creek Solutions Inc. be liable for any damages whatsoever (including without limitation to damages for loss of business profits, loss of business information, business interruption, and the like) arising out of the use of, or inability to use this program even if Clear Creek Solutions Inc. or their authorized representatives have been advised of the possibility of such damages. Software Copyright © by : Clear Creek Solutions, Inc. 2005-2024; All Rights Reserved.

Clear Creek Solutions, Inc.
6200 Capitol Blvd. Ste F
Olympia, WA. 98501
Toll Free 1(866)943-0304
Local (360)943-0304

www.clearcreeksolutions.com