



Construction Stormwater Pollution Prevention Plan

PREPARED FOR:

Larson Automotive Group
1409 Alexander Avenue East
Fife, WA 98424-1109

PROJECT:

Larson River Road Storage
8424 River Road
Puyallup, WA 98371
2160102.10

PREPARED BY:

Dan Osier, PE
Project Engineer

Michael Hager, PE
Project Engineer

REVIEWED BY:

Todd C. Sawin, PE, DBIA, LEED AP
Principal

DATE:

May 2016
Revised June 2021



Construction Stormwater Pollution Prevention Plan

PREPARED FOR:

Larson Automotive Group
1409 Alexander Avenue East
Fife, WA 98424-1109

PROJECT:

Larson River Road Storage
8424 River Road
Puyallup, WA 98371
2160102.10

PREPARED BY:

Dan Osier, PE
Project Engineer

Michael Hager, PE
Project Engineer

REVIEWED BY:

Todd C. Sawin, PE, DBIA, LEED AP
Principal

DATE:

May 2016
Revised June 2021

I hereby state that this [Construction Stormwater Pollution Prevention Plan](#) for the [Larson River Road Storage](#) project has been prepared by me or under my supervision, and meets the standard of care and expertise that is usual and customary in this community for professional engineers. I understand that [the City of Puyallup](#) does not and will not assume liability for the sufficiency, suitability, or performance of drainage facilities prepared by me.

Table of Contents

Section	Page
1.0 Introduction	1
2.0 Project Description	2
3.0 Existing Site Conditions	2
4.0 Adjacent Areas and Drainage	2
5.0 Critical Areas	2
6.0 Soils	2
7.0 Potential Erosion Problems	2
8.0 Construction Stormwater Pollution Prevention Elements	3
8.1 Mark Clearing Limits	3
8.2 Establish Construction Access	3
8.3 Control Flow Rates	3
8.4 Install Sediment Controls	3
8.5 Stabilize Soils	3
8.6 Protect Slopes	3
8.7 Protect Drain Inlets	4
8.8 Stabilize Channels and Outlets	4
8.9 Control Pollutants	4
8.9.1 Required BMPs	5
8.10 Control Dewatering	5
8.11 Maintain BMPs	6
8.12 Manage the Project	6
9.0 Construction Sequence and Phasing	7
9.1 Construction Sequence	7
9.2 Construction Phasing	7
10.0 Construction Schedule	7
11.0 Financial/Ownership Responsibilities	8
12.0 Certified Erosion and Sediment Control Lead (CESCL)	8

Exhibits

Exhibit 1

- A-1..... Vicinity Map
- A-2..... Existing Conditions Map
- A-3..... FEMA Flood Map
- A-4..... TESC Plan
- A-5..... TESC Notes and Details

Exhibit 2

Inspection Logs

Exhibit 3

Best Management Practices (BMPs)

- BMP C105..... Stabilized Construction Entrance
- BMP C120..... Temporary and Permanent Seeding
- BMP C121..... Mulching
- BMP C123..... Plastic Covering
- BMP C140..... Dust Control
- BMP C151..... Concrete Handling
- BMP C152..... Sawcutting and Surface Pollution Prevention
- BMP C160..... Certified Erosion and Sediment Control Lead
- BMP C220..... Storm Drain Inlet Protection
- BMP C233..... Silt Fence

1.0 Introduction

In 1972, Congress passed the Federal Water Pollution Control Act (FWPCA), also known as the Clean Water Act (CWA), to restore and maintain the quality of the nation's waterways. The ultimate goal was to make sure that rivers and streams were fishable, swimmable, and drinkable. In 1987, the Water Quality Act (WQA) added provisions to the CWA that allowed the Environmental Protection Agency to govern stormwater discharges from construction sites. The National Pollutant Discharge Elimination System (NPDES) General Permit includes provisions for development of a Stormwater Pollution Prevention Plan (SWPPP) to maximize the potential benefits of pollution prevention and sediment and erosion control measures at construction sites.

The proposed project will disturb more than 1 acre of area, and therefore is required to obtain an NPDES General Permit for Stormwater Associated with Construction Activities.

The 2005 Department of Ecology (DOE) *Stormwater Management Manual for Western Washington (SMMWW)* requires a Construction SWPPP for projects that add or replace more than 2,000 square feet of impervious surfaces. The proposed project will exceed this threshold; therefore, a Construction SWPPP is required.

Development, implementation, and maintenance of the Construction SWPPP will provide the selected General Contractor with the framework for reducing soil erosion and minimizing pollutants in stormwater during construction of the proposed project. The Construction SWPPP will:

- Define the characteristics of the site and the type of construction that will occur.
- Describe the practices that will be implemented to control erosion and the release of pollutants in stormwater.
- Create an implementation schedule to ensure that the practices described in this Construction SWPPP are in fact implemented, and to evaluate the plan's effectiveness in reducing erosion, sediment, and pollutant levels in stormwater discharged from the site.
- Describe the final stabilization/termination design to minimize erosion and prevent stormwater impacts after construction is complete.

This Construction SWPPP:

- Identifies the SWPPP Coordinator with a description of this person's duties.
- Identifies the Stormwater Pollution Prevention Team (SWPP Team) that will assist in implementation of the Construction SWPPP during construction.
- Describes the existing site conditions, including existing land use for the site, the soil types at the site, as well as the location of surface waters that are located on or next to the site.
- Identifies the body or bodies of water that will receive runoff from the construction site, including the ultimate body of water that receives the stormwater.
- Identifies the drainage areas and potential stormwater contaminants.
- Describes the stormwater management controls and various Best Management Practices (BMPs) necessary to reduce erosion, sediment, and pollutants in stormwater discharge.
- Describes the facility monitoring plan and how controls will be coordinated with construction activities.
- Describes the implementation schedule and provisions for amendment of the plan.

2.0 Project Description

The Larson River Road Storage project proposes to develop an approximately 1.96-acre site located on Tax Parcels 0420204282 and 0420204069 in the city of Puyallup, Washington. The site is located within the NE Quarter of the SE Quarter of the NE Quarter of Section 20, Township 20N, Range 4E, of the Willamette Meridian (see Exhibit A-1 for the Vicinity Map).

The developed site includes paved vehicle storage areas and utilities. There will be six existing buildings to remain in the site. Perimeter and island landscaping will be provided, as required by the City of Puyallup. The paved areas will drain to proposed catch basins located at the storage lot's proposed low points. Runoff collected in these catch basins shall be treated using a Contech 72-inch StormFilter manhole with seven 18-inch cartridges prior to discharging east to the existing storm trunk line located below 15th Street NW, which discharges into the Puyallup River.

The proposal will follow the stormwater management design criteria outlined in the DOE 2005 *SMMWW*. Control methods during construction include working during the dry season, minimizing the amount of area that is disturbed at any given time, installing a stabilized construction entrance, placing inlet protection at catch basins, and utilizing silt fence at the perimeter of the site, if necessary.

3.0 Existing Site Conditions

The existing area is approximately 7.47 acres and is currently: undeveloped/unpaved lots, with both gravel and grass cover; residential homes with landscaping and drive access; and fully developed commercial lots. The site discharges to an existing depression on the eastern side of the site through sheet flow and conveyance through several catch basins; to the city conveyance system in River Road; and to the city conveyance system in 15th Street. See the Stormwater Site Plan report for more information. Due to the poor condition of the existing stormwater facilities in the undeveloped and residential lots, it is unknown where the ultimate discharge location of the project site is. However, it appears that stormwater likely ponds until it infiltrates onsite. A topographic survey of the project site area was prepared by AHBL and shows existing site conditions and elevations. See Exhibit 1, A-2 for the Existing Conditions Map.

4.0 Adjacent Areas and Drainage

The site is bordered by developed businesses to the north west; River Road to the north; 15th Street NW to the east; and multi-family housing to the south and the northern half of the western border; undeveloped land on the southern half of the western border.

5.0 Critical Areas

There are no known critical areas on or near the project site. The Puyallup River is approximately 150 feet from the north of the site.

6.0 Soils

Soil conditions for the site are classified as predominantly Puyallup fine sandy loam by the Natural Resources Conservation Service (NRCS).

7.0 Potential Erosion Problems

There are no known erosion problems at or near the site.

8.0 Construction Stormwater Pollution Prevention Elements

The purpose of this section is to describe how each of the 12 Construction Stormwater Pollution Prevention elements has been addressed and to identify the type and location of BMPs used to satisfy the required element. If an element is not applicable to the project, a reason is provided.

8.1 Mark Clearing Limits

Prior to beginning land-disturbing activities, clearing limits will be marked with high visibility plastic or metal fence (BMP C103). Native vegetation located within the required buffers surrounding the private site shall be protected where practical.

8.2 Establish Construction Access

A stabilized construction entrance (BMP C105) is proposed from River Road through Tax Parcel 0420204281, entering the project site through the northwest corner. If sediment is transported onto the road surface, the road shall be cleaned each day by shoveling or sweeping prior to washing. Sediment removal by washing alone will not be allowed. If sediment is tracked from the site, the City of Puyallup may require stabilization of internal roads and car storage areas to contain the sediment or require the installation of a wheel wash basin.

8.3 Control Flow Rates

The minimal runoff from the construction site will be contained onsite using the proposed methods shown on the Temporary Erosion and Sedimentation Control (TESC) Plan (see Exhibit 1, A-4).

8.4 Install Sediment Controls

As part of the initial construction activities, BMPs will be installed to trap sediment onsite. The identified BMPs include Silt Fencing (BMP C233) and use of Inlet Protection (BMP C220) for existing catch basins and proposed catch basins within the project area and in adjacent streets that may receive runoff.

8.5 Stabilize Soils

Exposed areas and soil stockpiles must be stabilized according to the following schedule:

1. From April 1 to October 31, all disturbed areas at final grade and all exposed areas that are scheduled to remain unworked for more than 30 days shall be stabilized within 10 days.
2. From November 1 to March 31, all exposed soils at final grade shall be stabilized immediately using permanent or temporary measures. Exposed soils with an area greater than 5,000 square feet that are scheduled to remain unworked for more than 24 hours, and exposed areas of less than 5,000 square feet that will remain unworked for more than 7 days shall be stabilized immediately.

All disturbed areas that are not planned to be constructed on within 90 days from time of clearing and grading shall be revegetated with the native vegetation.

8.6 Protect Slopes

The existing site has already been developed and is relatively flat. Soil stabilization BMPs shown in Section 8.5 will be adequate to protect exposed slopes.

8.7 Protect Drain Inlets

Storm drain inlets shall be protected so that surface water runoff does not enter the conveyance system without first being filtered. Inlets shall be inspected weekly, at a minimum, and daily during storm events. Storm Drain Inlet Protection (BMP C220) will be provided.

8.8 Stabilize Channels and Outlets

Proposed outlets will be connected to existing stormwater facilities.

8.9 Control Pollutants

All waste materials will be collected and stored in a securely closed metal dumpster. All trash and construction debris from the site will be deposited in the dumpster. The dumpster will be emptied a minimum of once per week, and the trash will be hauled to the local landfill. No construction materials will be buried onsite. All personnel will be instructed regarding the correct procedure for waste disposal. All sanitary waste will be collected from the portable units a minimum of three times per week. Good housekeeping and spill control practices will be followed during construction to minimize stormwater contamination from petroleum products, fertilizers, and concrete.

Table 1 below lists several pollutants that are commonly found on construction sites that have the potential to contaminate storm runoff. These pollutants will be present, mainly in areas of building and pavement construction. The Contractor and the SWPPP/TESC Coordinator will be responsible for identifying areas where these pollutants are being used and monitor runoff coming from these areas. Pollutant sources will be covered with plastic if contaminated runoff is observed from these areas. If contaminated runoff is found in the sediment trap or soils, the Erosion Control Specialist will direct the Contractor to remove the polluted water/soil and dispose of it in an approved area offsite.

Table 1 – Potential Construction Site Stormwater Pollutants

Trade Name Material	Chemical/Physical Description ⁽¹⁾	Stormwater Pollutants ⁽¹⁾
Pesticides (insecticides, fungicides, herbicide, rodenticides)	Various colored to colorless liquid, powder, pellets, or grains	Chlorinated hydrocarbons, organophosphates, carbamates, arsenic
Fertilizer	Liquid or solid grains	Nitrogen, phosphorous
Plaster	White granules or powder	Calcium sulphate, calcium carbonate, sulfuric acid
Cleaning solvents	Colorless, blue, or yellow-green liquid	Perchloroethylene, methylene chloride, trichloroethylene, petroleum distillates
Asphalt	Black solid	Oil, petroleum distillates
Concrete	White solid	Limestone, sand
Glue, adhesives	White or yellow liquid	Polymers, epoxies
Paints	Various colored liquid	Metal oxides, Stoddard solvent, talc, calcium carbonate, arsenic
Curing compounds	Creamy white liquid	Naphtha
Wastewater from construction equipment washing	Water	Soil, oil & grease, solids
Wood preservatives	Clear amber or dark brown liquid	Stoddard solvent, petroleum distillates, arsenic, copper, chromium
Hydraulic oil/fluids	Brown oily petroleum hydrocarbon	Mineral oil

Trade Name Material	Chemical/Physical Description ⁽¹⁾	Stormwater Pollutants ⁽¹⁾
Gasoline	Colorless, pale brown or pink petroleum hydrocarbon	Benzene, ethyl benzene, toluene, xylene, MTBE
Diesel fuel	Clear, blue-green to yellow liquid	Petroleum distillate, oil & grease, naphthalene, xylenes
Kerosene	Pale yellow liquid petroleum hydrocarbon	Coal oil, petroleum distillates
Antifreeze/coolant	Clear green/yellow liquid	Ethylene glycol, propylene glycol, heavy metals (copper, lead, zinc)
Erosion	Solid Particles	Soil, Sediment

⁽¹⁾ Data obtained from MSDS when available

8.9.1 Required BMPs

The following BMPs or equivalent measures are required of all businesses and agencies during concrete pouring and asphalt application at temporary sites:

- Employees must be educated on the pollution hazards of concrete and asphalt application and cutting.
- Loose aggregate chunks and dust must be swept or shoveled and collected (not hosed down a storm drain) for recycling or proper disposal at the end of each work day, especially at work sites such as streets, driveways, parking lots, sidewalks, curbs, and gutters where rain can readily pick up the loose material and carry it to the nearest stormwater conveyance. Small amounts of excess concrete, grout, and mortar can be disposed of in the trash.
- Storm drain covers or similarly effective containment devices must be placed over all nearby drains at the beginning of each day. Shovel or vacuum slurry and remove from the site. All accumulated runoff and solids must be collected and properly disposed at the end of each workday, or more often if necessary.
- Exposed aggregate washing, where the top layer of unhardened concrete is hosed or scraped off to leave a rough finish, must be done with a mechanism for containment and collection of the discarded concrete slurry (such as the storm drain covers mentioned above). The easiest way to contain the washwater will be to direct the washings to a hole in the ground where the water can percolate into the ground and the solids later covered with soil.
- If directed to a drain, a catch basin filter insert must be used to remove the solids. This is especially useful if the activity must proceed on rainy days.
- Cleaning of concrete application and mixing equipment or concrete vehicles on the work site must be done in a designated area where the rinse water is controlled. The rinse water must either be collected for proper disposal or put into a hole in the ground where the water can percolate away and the solids later covered with soil or recovered and disposed or recycled.

The use of any treatment BMP must not result in the violation of groundwater, surface water, or drinking water quality standards.

8.10 Control Dewatering

If groundwater is encountered during construction, dewatering control measures shall be used to prevent untreated discharge of sediment-laden water. Measures may include vehicle transport

offsite for legal disposal in a manner that does not pollute surface waters, or use of a sedimentation bag with outfall to a ditch or swale for small volumes of localized dewatering.

8.11 Maintain BMPs

Temporary and permanent erosion and sediment control BMPs shall be maintained and repaired as needed to assure performance of their intended functions.

Sediment control BMPs such as silt fencing and drain inlet protection shall be inspected weekly or after a runoff-producing event. Temporary erosion and sediment control BMPs will be removed within 30 days after final site stabilization is achieved. The following inspection and maintenance practices will be used to maintain erosion and sediment controls:

- Built-up sediment will be removed from silt fencing when it has reached one-third the height of the fence.
- Silt fences will be inspected for depth of sediment, tears in the fabric, attachment to the fence posts, and to determine that fence posts are firmly in the ground. Accumulated sediment will be removed from behind the fence.
- Temporary and permanent seeding will be inspected for bare spots, washouts, and healthy growth.
- The Contractor Certified Erosion and Sedimentation Control Lead (CESCL) will provide erosion control inspection services and stormwater disposal monitoring through construction. The City Inspector will be notified of daily construction activities and scheduled meetings between the Erosion Control Inspector and the Contractor.

The maintenance inspection report will be made after each inspection. Copies of the report forms to be completed by the SWPPP Coordinator are attached as Exhibit 2 of this Construction SWPPP. Completed forms will be provided to the City Inspector and will also be maintained onsite during the entire construction project. If construction activities or design modifications are made to the site plan that could impact stormwater, or if AHBL determines that the measures are not adequate to prevent erosion and the discharge of sediment from the site (based on turbidity measurements), this Construction SWPPP will be amended appropriately. The amended Construction SWPPP will have a description of the new activities that contribute to the increased pollutant loading and the planned source control activities.

8.12 Manage the Project

The following practices will be required during construction to properly manage activities:

- Comply with seasonal work limitations.
- Inspect, maintain, and repair BMPs.
- Identify a Certified Erosion and Sediment Control Lead (CESCL).
- Maintain the Construction SWPPP onsite at all times, including narrative and plans.

9.0 Construction Sequence and Phasing

9.1 Construction Sequence

The construction sequence is described below:

1. Arrange and attend a pre-construction meeting with the City of Puyallup.
2. Stake/flag clearing and construction limits.
3. Construct all temporary erosion control BMPs according to the TESC plan. Install inlet sediment protection in existing catch basins.
4. Install construction entrance.
5. Demolish existing site features indicated for removal.
6. Maintain erosion control measures in accordance with City of Puyallup standards and manufacturer recommendations.
7. Rough grade and fill site. All grading shall be done in conformance with the grading plan.
8. Construct storm system and install inlet sediment protection to new basins.
9. Install all remaining site utilities and associated infrastructure.
10. Apply erosion control mulch and seeding, straw mulch or equal, to areas that will not be brought to final grade or permanently vegetated within 7 days of exposure during the dry season, and 2 days of exposure during the wet season (October 1 – April 30).
11. Relocate erosion control measures or install new measures so that, as the site conditions change, the erosion and sediment control is always in accordance with the City of Puyallup Construction SWPPP minimum requirements.
12. Final grade site and install final surface treatments. Ensure that surface water is positively directed toward proposed storm collection facilities.
13. Remove remaining temporary erosion control items once site has been stabilized and upon approval of the City of Puyallup.

9.2 Construction Phasing

Work under this permit will be constructed in a single phase.

10.0 Construction Schedule

Construction is scheduled to begin in summer of 2016 and is expected to be completed in fall of 2016. The majority of earth moving activities will be scheduled during the dry season. During construction, measures will be taken to prevent the transportation of sediment from the site to receiving waters. These measures include the use of:

- Stabilized Construction Entrance (BMP C105)
- Temporary and Permanent Seeding (BMP C120)
- Mulching (BMP C121)

- Plastic Covering (BMP C123)
- Dust Control (BMP C140)
- Storm Drain Inlet Protection (BMP C220)
- Silt Fence (BMP C233)

11.0 Financial/Ownership Responsibilities

The contractor is responsible for obtaining performance and maintenance bonds in accordance with City of Puyallup requirements.

12.0 Certified Erosion and Sediment Control Lead (CESCL)

The General Contractor shall be required to provide a CESCL prior to construction. Once this individual is identified, the City Inspector will be notified.

The Contractor will designate their CESCL here:

Name: _____

Address: _____

Phone: _____

Fax Number: _____

The CESCL is required to meet DOE certification requirements. The City Inspector will be provided with CESCL information.

The duties of the CESCL include:

- Implement the Construction SWPPP/TESC plan with the aid of the SWPP Team.
- Oversee maintenance practices identified as BMPs in the Construction SWPPP.
- Conduct or provide for inspection and monitoring activities.
- Sample stormwater for turbidity using a turbidity meter.
- Identify other potential pollutant sources and make sure they are added to the plan.
- Identify any deficiencies in the Construction SWPPP and make sure they are corrected.
- Ensure that any changes in construction plans are addressed in the Construction SWPPP.

To aid in the implementation of the Construction SWPPP, the members of the SWPP Team include the following: General Contractor, CESCL, City of Puyallup Inspector, City of Puyallup, the geotechnical engineering consultant, and AHBL.

The General Contractor will ensure that all housekeeping and monitoring procedures are implemented, while the CESCL will ensure the integrity of the structural BMPs. The SWPP Team will observe construction and erosion control practices and recommend revisions or additions to the Construction SWPPP and drawings.

This analysis is based on data and records either supplied to or obtained by AHBL, Inc. These documents are referenced within the text of the analysis. The analysis has been prepared utilizing procedures and practices within the standard accepted practices of the industry. We conclude that this project, as proposed, will not create any new problems within the existing downstream drainage system. This project will not noticeably aggravate any existing downstream problems due to either water quality or quantity.

AHBL, Inc.

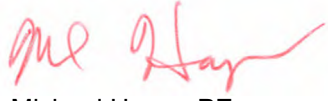

Michael Hager, PE
Project Engineer

MCH/DJO/Isk

May 2016
Revised June 2021

Q:\2016\2160102\10_CIVNON_CAD\REPORTS\CSWPPP 20210616\20210616 Rpt (CSWPPP) 2160102.10.docx

Exhibit 1

A-1.....Vicinity Map
A-2.....Existing Conditions Map
A-3.....FEMA Flood Map
A-4.....TESC Plan
A-5.....TESC Notes and Details

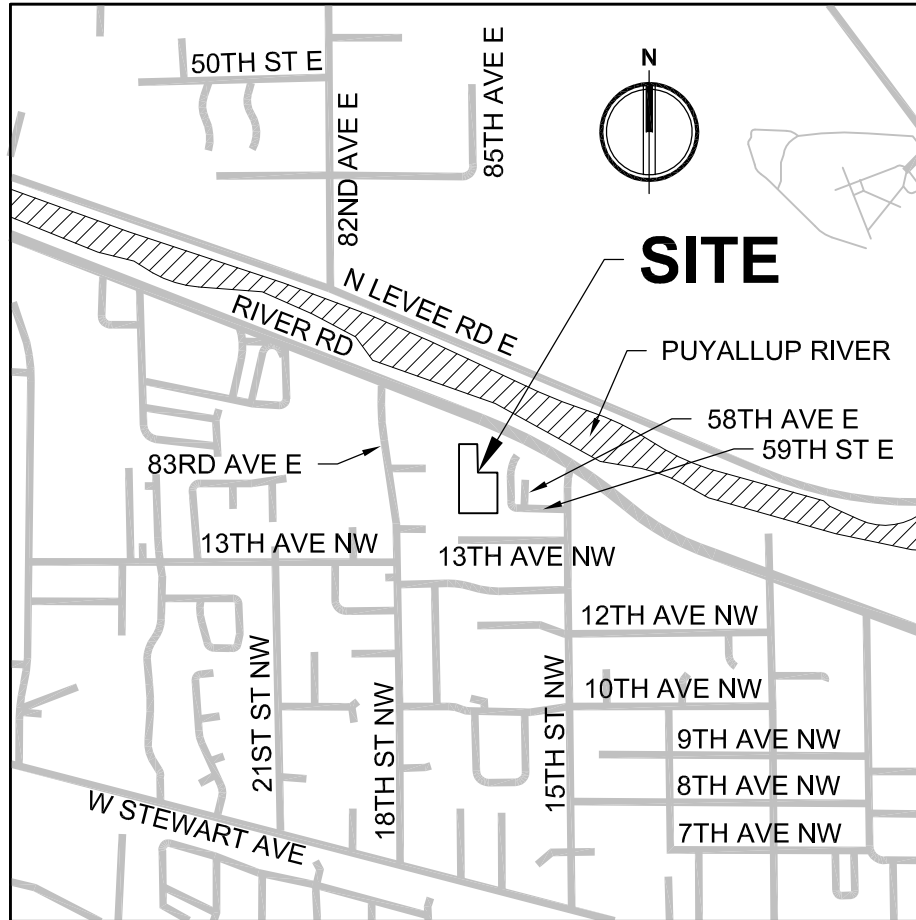

VICINITY MAP

SCALE: 1" = 1/4 MILE (1320')



TACOMA · SEATTLE
 2215 North 30th Street, Suite 300, Tacoma, WA 98403 253.383.2422 TEL.
 316 Occidental Avenue South, Suite 320, Seattle, WA 98104 206.267.2425 TEL.

*Civil Engineers
 Structural Engineers
 Landscape Architects
 Community Planners
 Land Surveyors
 Neighbors*

LARSON RIVER ROAD STORATE
 2160102.10

VICINITY MAP
05/06/2016

A-1

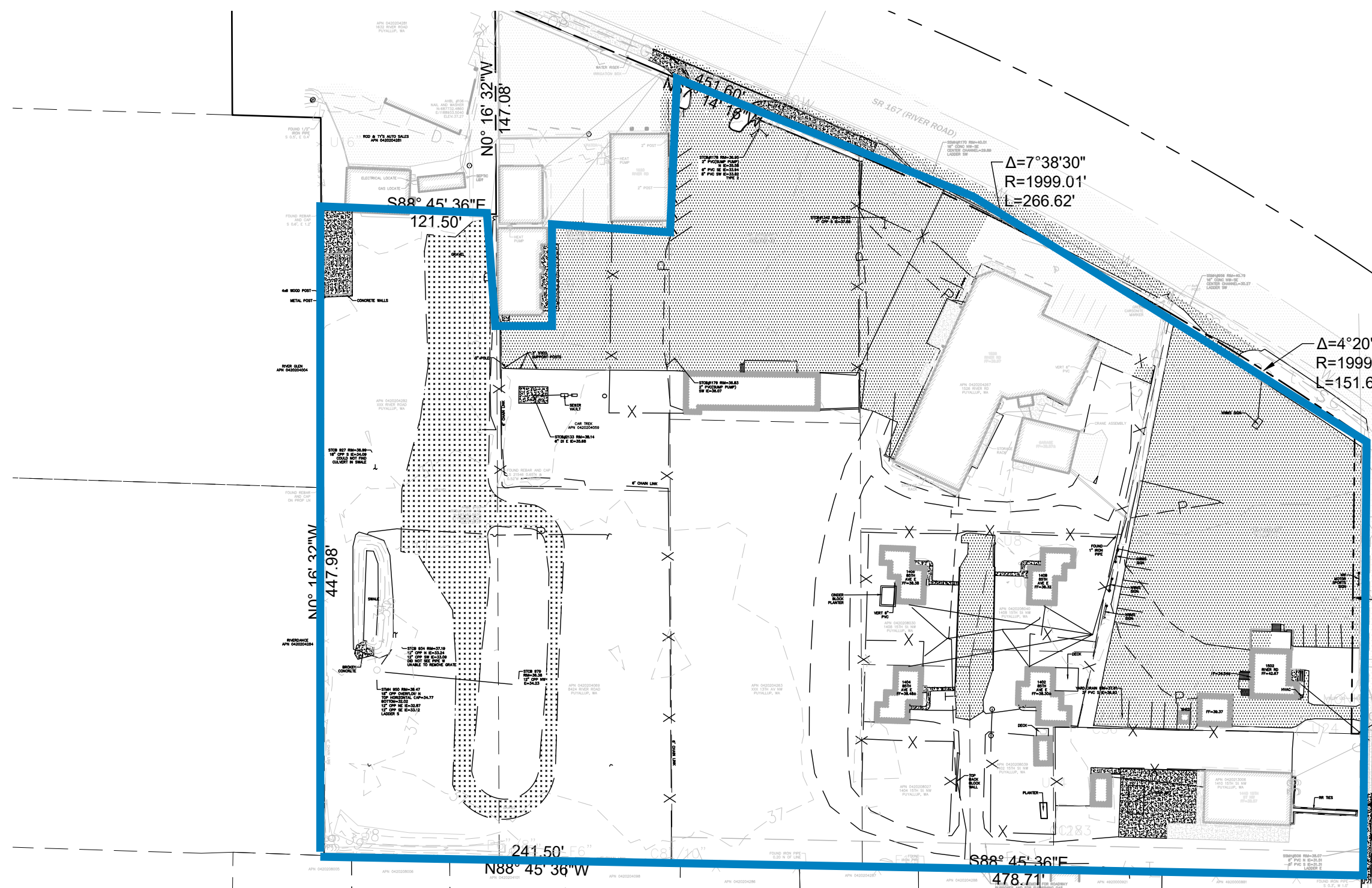
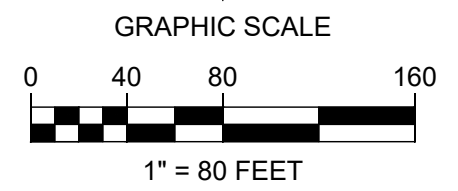
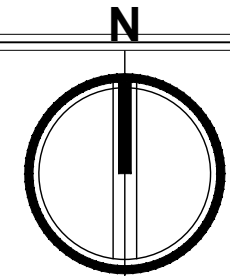

N0° 36' 46"E
210.27'
S88° 45' 36"E
8.00'
N0° 36' 46"E
100.01'

AHBL
TACOMA · SEATTLE
2215 North 30th Street, Suite 300, Tacoma, WA 98403 253.383.2422 TEL
316 Occidental Avenue South, Suite 320, Seattle, WA 98104 206.267.2425 TEL

Civil Engineers
Structural Engineers
Landscape Architects
Community Planners
Land Surveyors
Neighbors

LARSON RIVER ROAD STORAGE
2160102.10
EXISTING CONDITIONS MAP

A-2

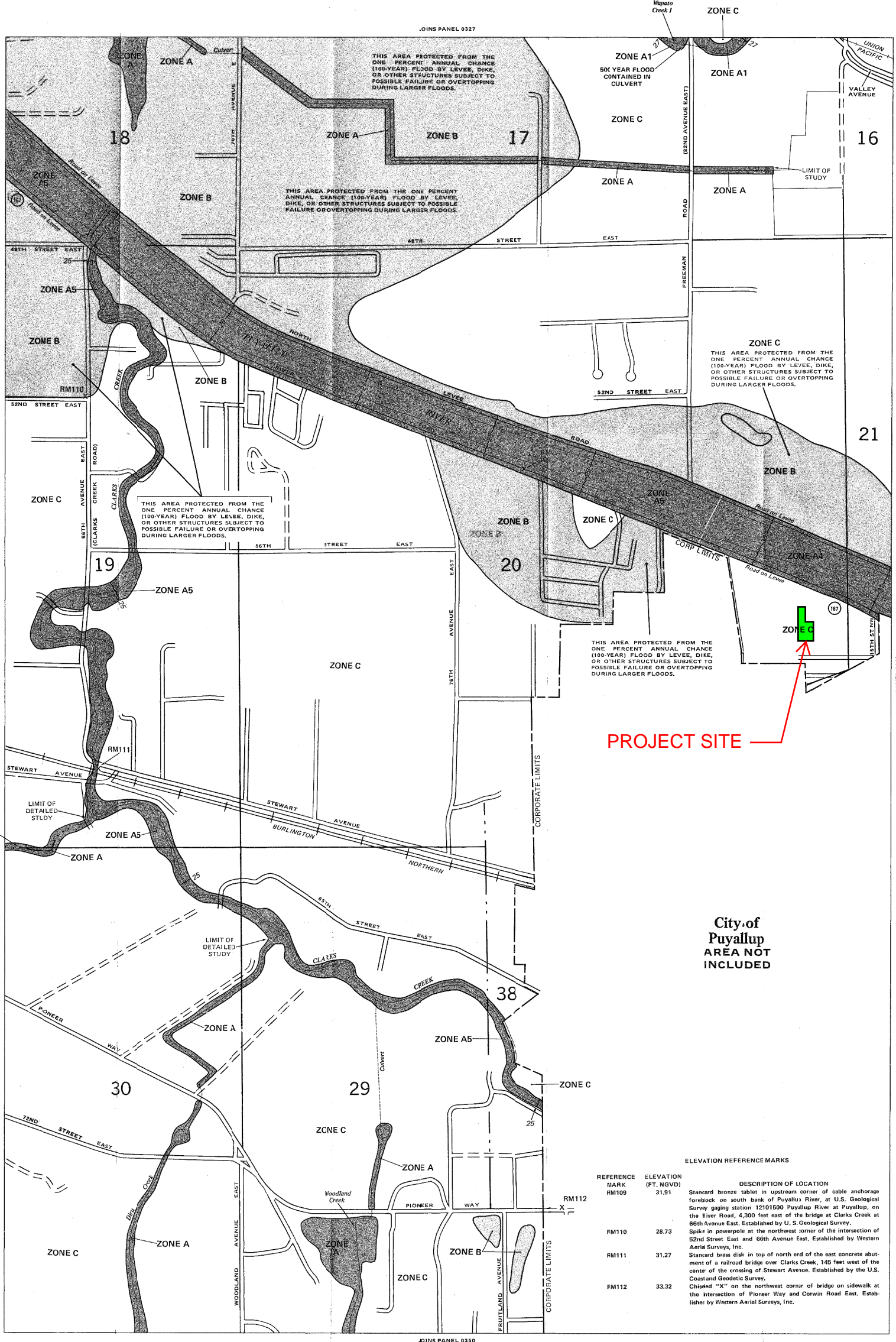

KEY TO MAP

500-Year Flood Boundary
 100-Year Flood Boundary
 Zone Designations

100-Year Flood Boundary
 500-Year Flood Boundary
 Base Flood Elevation Line With Elevation In Feet**
 Base Flood Elevation In Feet Where Uniform Within Zone**
 Elevation Reference Mark
 Zone E Boundary
 River Mile

513
 (EL 987)
 RM7x
 +M1.5

**Referenced to the National Geodetic Vertical Datum of 1929

EXPLANATION OF ZONE DESIGNATIONS

ZONE	EXPLANATION
A	Areas of 100-year flood; base flood elevations and flood hazard factors not determined.
A0	Areas of 100-year shallow flooding where depths are between one (1) and three (3) feet; average depths of inundation are shown, but no flood hazard factors are determined.
AH	Areas of 100-year shallow flooding where depths are between one (1) and three (3) feet; base flood elevations are shown, but no flood hazard factors are determined.
A1-A30	Areas of 100-year flood; base flood elevations and flood hazard factors determined.
A99	Areas of 100-year flood to be protected by flood protection system under construction; base flood elevations and flood hazard factors not determined.
B	Areas between limits of the 100-year flood and 500-year flood; or certain areas subject to 100-year flooding with average depths less than one (1) foot or where the contributing drainage area is less than one square mile; or areas protected by levees from the base flood. (Medium shading)
C	Areas of minimal flooding. (No shading)
D	Areas of undetermined, but possible, flood hazards.
V	Areas of 100-year coastal flood with velocity (wave action); base flood elevations and flood hazard factors not determined.
V1-V30	Areas of 100-year coastal flood with velocity (wave action); base flood elevations and flood hazard factors determined.

NOTES TO USER

Certain areas not in the special flood hazard areas (zones A and V) may be protected by flood control structures.

This map is for use in administering the National Flood Insurance Program; it does not necessarily identify all areas subject to flooding, particularly from local drainage sources of small size, or all planimetric features outside special flood hazard areas.

Coastal base flood elevations apply only landward of the shoreline shown on this map.

For adjoining map panels, see separately printed Index To Map Panels.

INITIAL IDENTIFICATION:
 OCTOBER 26, 1977

FLOOD HAZARD BOUNDARY MAP REVISIONS:
 APRIL 15, 1980

FLOOD INSURANCE RATE MAP EFFECTIVE:
 AUGUST 19, 1987

Refer to the FLOOD INSURANCE RATE MAP EFFECTIVE date shown on this map to determine when actuarial rates apply to structures in the zones where elevations or depths have been established.

To determine if flood insurance is available in this community, contact your insurance agent, or call the National Flood Insurance Program, at (800) 638-6620.

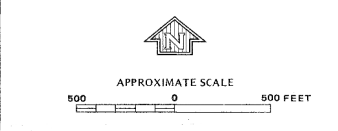

ELEVATION REFERENCE MARKS

REFERENCE MARK	ELEVATION (FT. NGVD)	DESCRIPTION OF LOCATION
RM109	31.91	Standard bronze tablet in upstream corner of cable anchorage forelock on south bank of Puyallup River, at U.S. Geological Survey gaging station 12101500 Puyallup River at Puyallup, on the River Road, 4,300 feet east of the bridge at Clark's Creek at 68th Avenue East. Established by U.S. Geological Survey.
FM110	28.73	Spikes in powerpole at the northwest corner of the intersection of 52nd Street East and 68th Avenue East. Established by Western Aerial Surveys, Inc.
RM111	31.27	Standard brass disk in top of north end of the east concrete abutment of a railroad bridge over Clark's Creek, 145 feet west of the center of the crossing of Stewart Avenue. Established by the U.S. Coast and Geodetic Survey.
FM112	33.32	Chisled "X" on the northwest corner of bridge on sidewalk at the intersection of Pioneer Way and Corwin Road East. Established by Western Aerial Surveys, Inc.

NOTE: MAP AREA SHOWN ON THIS PANEL IS LOCATED WITHIN TOWNSHIP 20 NORTH, RANGE 4 EAST

NATIONAL FLOOD INSURANCE PROGRAM

FIRM
 FLOOD INSURANCE RATE MAP

PIERCE COUNTY, WASHINGTON
 (UNINCORPORATED AREAS)

PANEL 329 OF 1375
 (SEE MAP INDEX FOR PANELS NOT PRINTED)

COMMUNITY-PANEL NUMBER
 530138 0329 C

EFFECTIVE DATE:
 AUGUST 19, 1987

Federal Emergency Management Agency

LARSON RIVER ROAD AUTO STORAGE

A PORTION OF THE NE 1/4 OF THE SE 1/4 OF SEC. 20, TWN. 20 N., RGE. 04 E. W.M.
CITY OF PUYALLUP, PIERCE COUNTY, WASHINGTON.

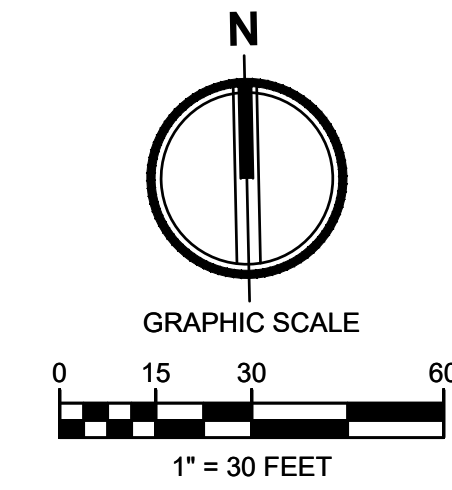

Project Title:
LARSON RIVER ROAD STORAGE

Client:
LARSON AUTOMOTIVE GROUP
1409 ALEXANDER AVENUE EAST
FIFE, WA 98424-1109
JOSH LARSON

Job No.
2160102.10

Issue Set & Date:
PERMIT SET
06/15/2021



NOTICE
ALTERATION OF THIS DOCUMENT SHALL MAINTAIN THE PROFESSIONAL SEAL AND SIGNATURE. PRODUCTION OF THIS DOCUMENT DOES NOT CONSTITUTE A WAIVER OF THE ENGINEER'S LIABILITY. THIS DOCUMENT IS FOR THE PROJECT IDENTIFIED IN THE TITLE BLOCK AND IS NOT TO BE USED FOR ANY OTHER PROJECT, IN ADDITION TO THAT PROJECT OR FOR ANY OTHER PROJECT.

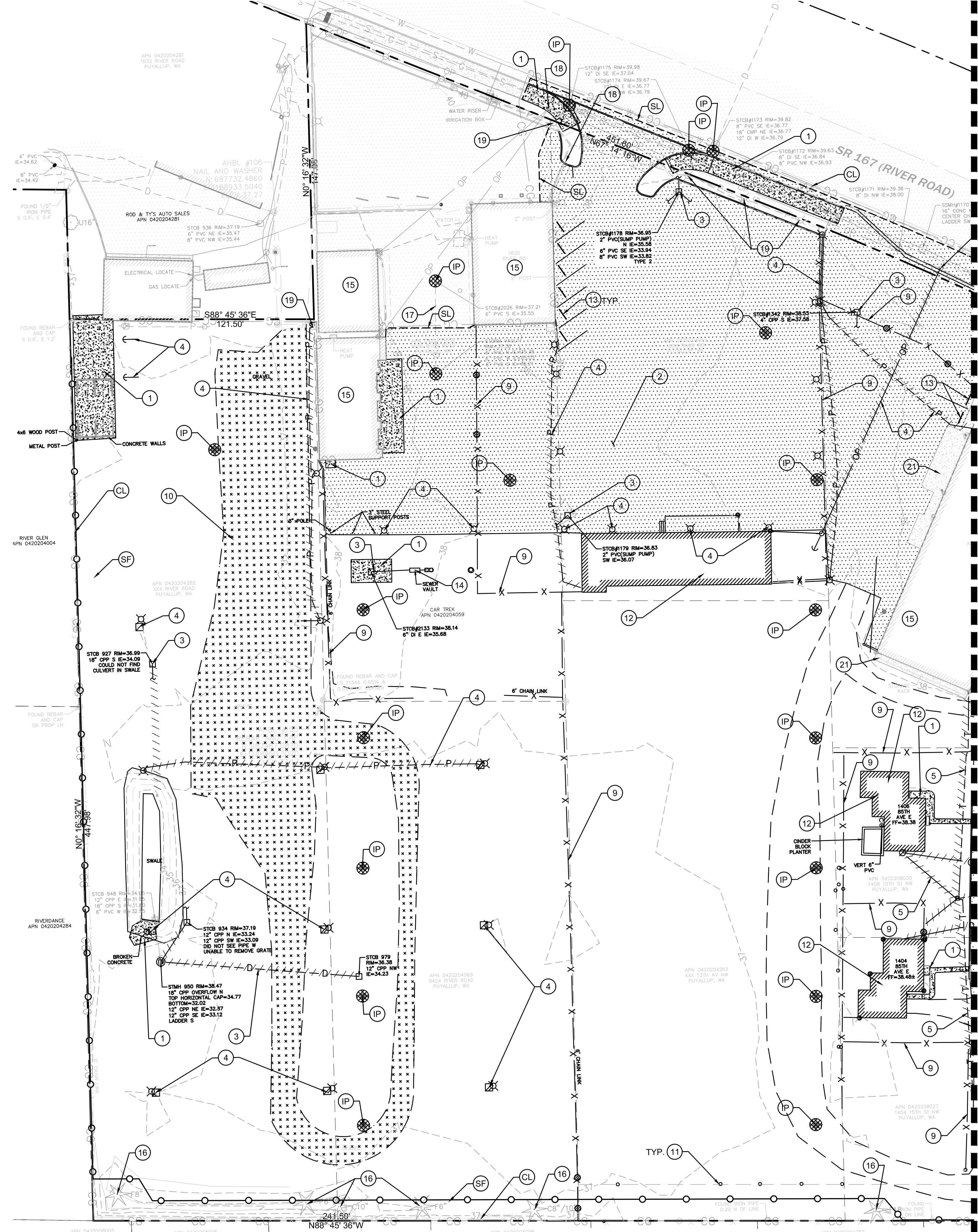

MATCHLINE SEE SHEET C1.1

- ### KEY NOTES
- DEMOLISH CONCRETE
 - DEMOLISH HMA
 - REMOVE AND DEMOLISH EXISTING STORM CB AND PIPE
 - REMOVE AND DEMOLISH EXISTING LIGHTS AND POWER
 - REMOVE AND DEMOLISH EXISTING TELEPHONE LINE
 - PROTECT EXISTING POWER
 - DEMOLISH EXISTING SIGNS
 - DEMOLISH EXISTING TREE
 - REMOVE EXISTING FENCE
 - REMOVE EXISTING GRAVEL
 - REMOVE BOLLARDS
 - REMOVE EXISTING BUILDING AND FEATURES
 - DEMOLISH EXISTING CURBSTOP
 - REMOVE AND DEMOLISH EXISTING SEWER
 - PROTECT EXISTING BUILDING AND UTILITY CONNECTIONS
 - PROTECT EXISTING TREE
 - PROTECT EXISTING STORM LINE
 - PROTECT EXISTING POWER LINE AND POLE
 - PROTECT EXISTING LIGHT POLE
 - PROTECT EXISTING WATER METER AND SERVICE TO BUILDING
 - PROTECT EXISTING CONCRETE TO REMAIN

- ### DEMOLITION NOTES
- DEMOLITION: IT IS THE INTENT UNDER THE WORK OF THIS CONTRACT TO INCLUDE, BUT NOT LIMITED TO, THE DEMOLITION OF ALL EXISTING BUILDINGS, PAVING, UTILITIES, BOLLARDS, GATES AND OTHER EXISTING SITE IMPROVEMENTS INCLUDING THE UNDERGROUND COMPONENTS AS CLARIFIED BY THIS DRAWING. IT IS THE CONTRACTOR'S RESPONSIBILITY TO FULLY REVIEW THE SITE CONDITIONS AND TO CORRELATE THESE OBSERVATIONS WITH THE PROJECT WORK AND INCLUDE ALL NECESSARY DEMOLITION, WHETHER SHOWN OR NOT, AND INCLUDE ALL SUCH COSTS IN THE SCOPE OF WORK.
 - CLEARING: IT IS THE INTENT UNDER THE WORK OF THIS CONTRACT TO CONDUCT ALL CLEARING NECESSARY TO BE ABLE TO COMPLETE ALL THE WORK OF THIS PROJECT.
 - CONTRACTOR SHALL LEGALLY DISPOSE ALL DEMOLISHED AND REMOVED MATERIALS OFF THE OWNER'S PROPERTY UNLESS INDICATED OTHERWISE.
 - IT IS THE RESPONSIBILITY OF THE CONTRACTOR TO COMPLETELY COORDINATE UTILITY DEMOLITION WITH NEW CONSTRUCTION. CONTRACTOR SHALL ENSURE THAT ADEQUATE FIRE PROTECTION IN ACCORDANCE WITH THE FIRE MARSHALL'S REQUIREMENTS IS PROVIDED FOR THE NEW AND EXISTING BUILDINGS.
 - DEMOLITION WORK MAY OCCUR OUTSIDE OF PROJECT LIMIT.
 - CONTRACTOR TO VERIFY ELECTRICAL SERVICE LOCATIONS PRIOR TO DEMO TO ENSURE POWER IS MAINTAINED TO BUILDINGS BEING KEPT.

LEGEND

---	RIGHT-OF-WAY / PROPERTY LINE
CL	CLEARING / PROJECT LIMITS
CE	CONSTRUCTION ENTRANCE PER CITY OF PUYALLUP STD DETAIL 05-01-01
[Hatched]	REMOVE EXISTING ASPHALT
[Hatched]	REMOVE EXISTING CONCRETE
[Hatched]	2" ASPHALT GRIND AND OVERLAY
SF	SILT FENCE
IP	INLET PROTECTION
---	INTERCEPTOR SWALE
---	SAWCUT LINE
---	ROCK CHECK DAM
---	REMOVE EXISTING UTILITY
[Star]	REMOVE EXISTING TREE
[Star]	EXISTING TREE TO REMAIN
---	STORM LINE
---	GAS LINE
---	ELECTRICAL LINE
---	OHP
X	FENCE
[Hatched]	ASPHALT
[Hatched]	GRAVEL
[Symbol]	BOLLARD
[Symbol]	STORM CATCH BASIN
[Symbol]	STORM MANHOLE
[Symbol]	GUY ANCHOR
[Symbol]	UTILITY POWER POLE
[Symbol]	JUNCTION BOX
[Symbol]	POWER METER
[Symbol]	LUMINAIRE

APPROVED
BY: CITY OF PUYALLUP
ENGINEERING SERVICES
DATE: _____
NOTE: THIS APPROVAL IS VOID AFTER 1 YEAR FROM APPROVAL DATE. THE CITY WILL NOT BE RESPONSIBLE FOR ERRORS AND/OR OMISSIONS ON THESE PLANS. FIELD CONDITIONS MAY DICTATE CHANGES TO THESE PLANS AS DETERMINED BY THE ENGINEERING SERVICES MANAGER.



Revisions:

Sheet Title:
TESC AND DEMOLITION PLAN

Designed by: MH
Drawn by: SBK
Checked by: TCS

Sheet No.
C1.0
2 of 11 Sheets



LARSON RIVER ROAD AUTO STORAGE

A PORTION OF THE NE 1/4 OF THE SE 1/4 OF SEC. 20, TWN. 20 N., RGE. 04 E. W.M.
CITY OF PUYALLUP, PIERCE COUNTY, WASHINGTON.

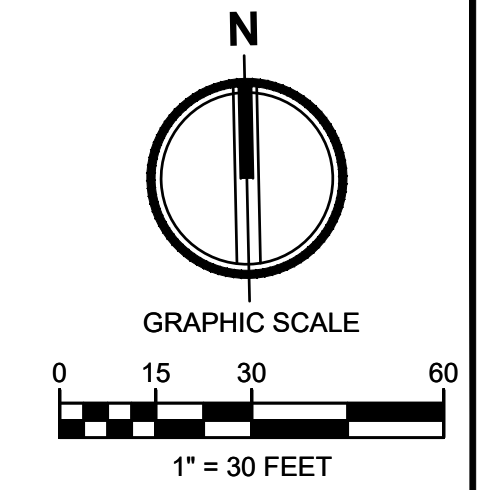

Project Title:
LARSON RIVER ROAD STORAGE

Client:
LARSON AUTOMOTIVE GROUP
1409 ALEXANDER AVENUE EAST
FIFE, WA 98424-1109
JOSH LARSON

Job No.
2160102.10

Issue Set & Date:
PERMIT SET
06/15/2021

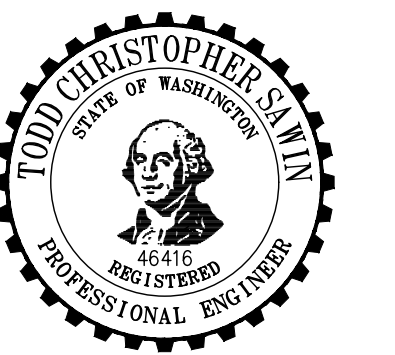

NOTICE
ALTERATION OF THIS DOCUMENT SHALL MAINTAIN THE PROFESSIONAL SEAL AND SIGNATURE. PRODUCTION OF THIS DOCUMENT DOES NOT CONSTITUTE A WAIVER OF THE ENGINEER'S LIABILITY FOR NEGLIGENCE OR OTHER PROFESSIONAL MALPRACTICE. THIS DOCUMENT IS TO BE USED FOR THE SPECIFIC PROJECT AND SITE ONLY. IT IS NOT TO BE USED FOR ANY OTHER PROJECT, ADDITION TO THAT PROJECT OR FOR ANY OTHER PROJECT.

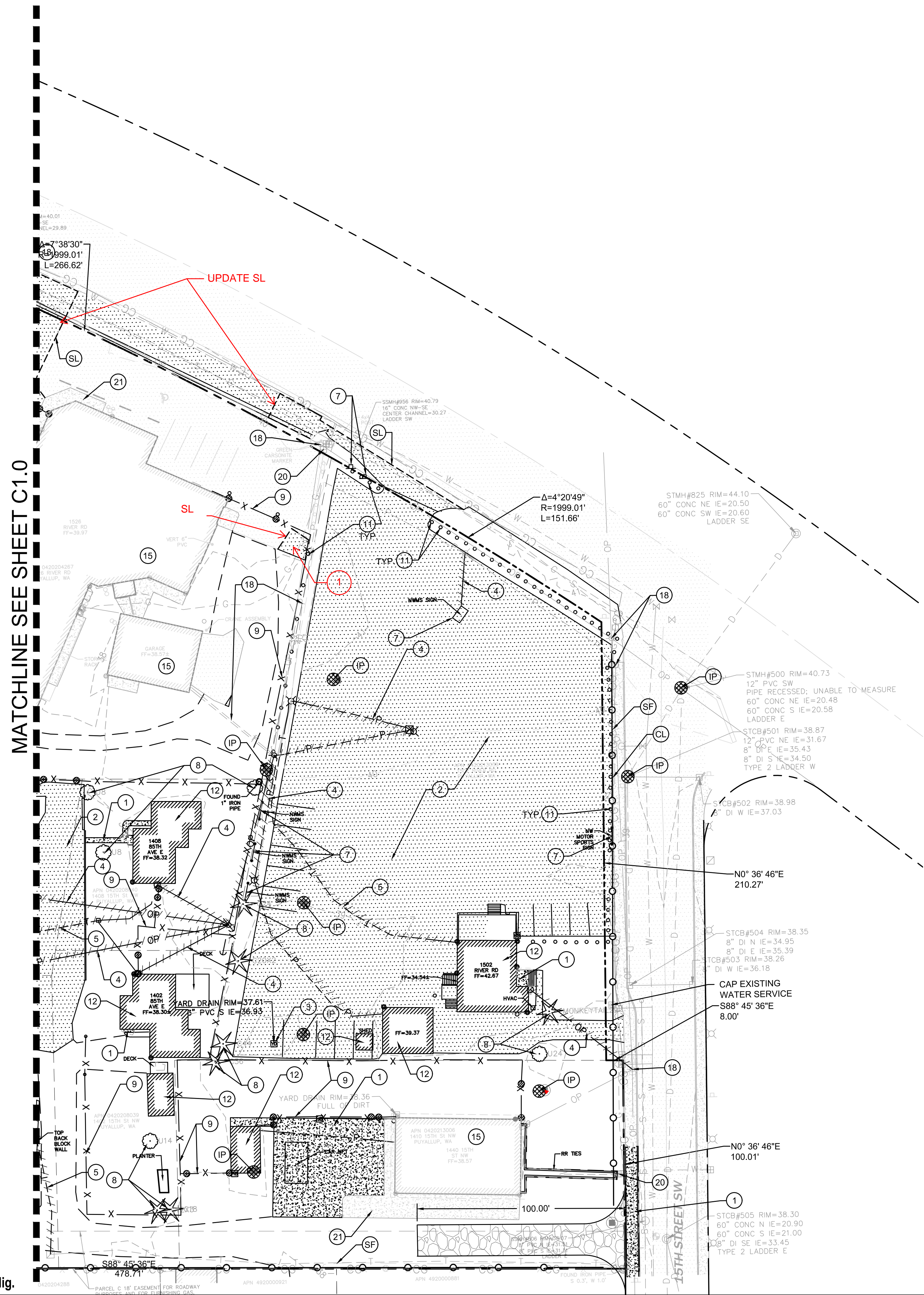

MATCHLINE SEE SHEET C1.0

KEY NOTES

- 1 DEMOLISH CONCRETE
- 2 DEMOLISH HMA
- 3 REMOVE AND DEMOLISH EXISTING STORM CB AND PIPE
- 4 REMOVE AND DEMOLISH EXISTING LIGHTS AND POWER
- 5 REMOVE AND DEMOLISH EXISTING TELEPHONE LINE
- 6 PROTECT EXISTING POWER
- 7 DEMOLISH EXISTING SIGNS
- 8 DEMOLISH EXISTING TREE
- 9 REMOVE EXISTING FENCE
- 10 REMOVE EXISTING GRAVEL
- 11 REMOVE BOLLARDS
- 12 REMOVE EXISTING BUILDING AND FEATURES
- 13 DEMOLISH EXISTING CURBSTOP
- 14 REMOVE AND DEMOLISH EXISTING SEWER
- 15 PROTECT EXISTING BUILDING AND UTILITY CONNECTIONS
- 16 PROTECT EXISTING TREE
- 17 PROTECT EXISTING STORM LINE
- 18 PROTECT EXISTING POWER LINE AND POLE
- 19 PROTECT EXISTING LIGHT POLE
- 20 PROTECT EXISTING WATER METER AND SERVICE TO BUILDING
- 21 PROTECT EXISTING CONCRETE TO REMAIN

LEGEND

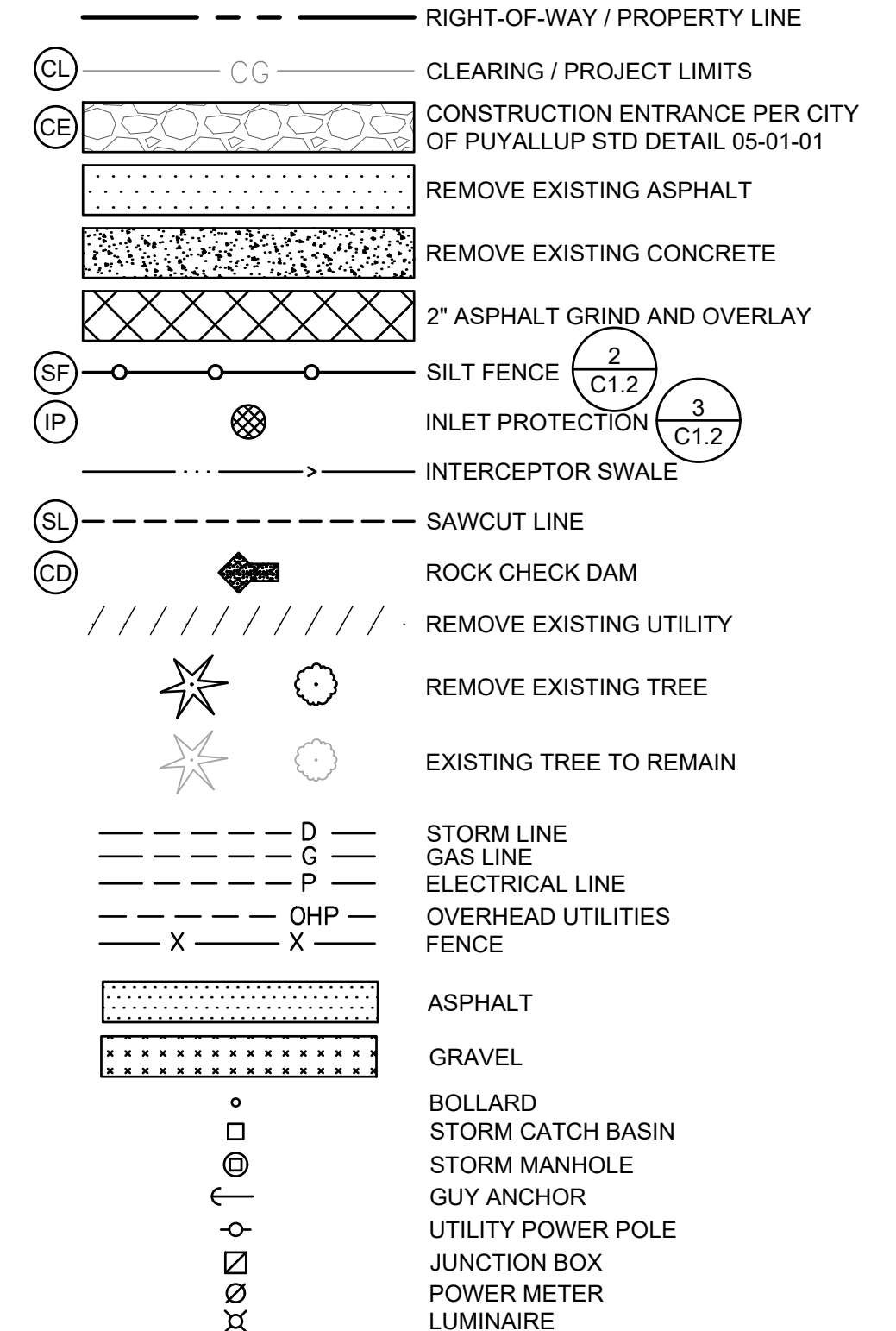

DEMOLITION NOTES

1. DEMOLITION: IT IS THE INTENT UNDER THE WORK OF THIS CONTRACT TO INCLUDE, BUT NOT LIMITED TO, THE DEMOLITION OF ALL EXISTING BUILDINGS, PAVING, UTILITIES, BOLLARDS, GATES AND OTHER EXISTING SITE IMPROVEMENTS INCLUDING THE UNDERGROUND COMPONENTS AS CLARIFIED BY THIS DRAWING. IT IS THE CONTRACTOR'S RESPONSIBILITY TO FULLY REVIEW THE SITE CONDITIONS AND TO CORRELATE THESE OBSERVATIONS WITH THE PROJECT WORK AND INCLUDE ALL NECESSARY DEMOLITION, WHETHER SHOWN OR NOT, AND INCLUDE ALL SUCH COSTS IN THE SCOPE OF WORK.
2. CLEARING: IT IS THE INTENT UNDER THE WORK OF THIS CONTRACT TO CONDUCT ALL CLEARING NECESSARY TO BE ABLE TO COMPLETE ALL THE WORK OF THIS PROJECT.
3. CONTRACTOR SHALL LEGALLY DISPOSE ALL DEMOLISHED AND REMOVED MATERIALS OFF THE OWNER'S PROPERTY UNLESS INDICATED OTHERWISE.
4. IT IS THE RESPONSIBILITY OF THE CONTRACTOR TO COMPLETELY COORDINATE UTILITY DEMOLITION WITH NEW CONSTRUCTION. CONTRACTOR SHALL ENSURE THAT ADEQUATE FIRE PROTECTION IN ACCORDANCE WITH THE FIRE MARSHALL'S REQUIREMENTS IS PROVIDED FOR THE NEW AND EXISTING BUILDINGS.
5. DEMOLITION WORK MAY OCCUR OUTSIDE OF PROJECT LIMIT.
6. CONTRACTOR TO VERIFY ELECTRICAL SERVICE LOCATIONS PRIOR TO DEMO TO ENSURE POWER IS MAINTAINED TO BUILDINGS BEING KEPT.

APPROVED

BY: _____
CITY OF PUYALLUP
ENGINEERING SERVICES
DATE: _____
NOTE: THIS APPROVAL IS VOID AFTER 1 YEAR FROM APPROVAL DATE. THE CITY WILL NOT BE RESPONSIBLE FOR ERRORS AND/OR OMISSIONS ON THESE PLANS. FIELD CONDITIONS MAY DICTATE CHANGES TO THESE PLANS AS DETERMINED BY THE ENGINEERING SERVICES MANAGER.

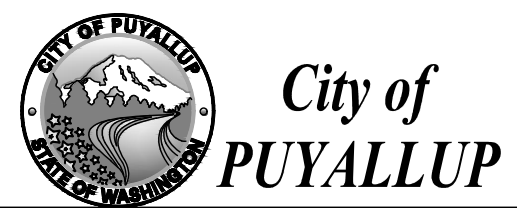

Revisions:

TESC AND DEMOLITION PLAN

Designed by: MH Drawn by: SBK Checked by: TCS

Sheet No.
C1.1
3 of 11 Sheets



LARSON RIVER ROAD AUTO STORAGE

A PORTION OF THE NE 1/4 OF THE SE 1/4 OF SEC. 20, TWN. 20 N., RGE. 04 E. W.M.
CITY OF PUYALLUP, PIERCE COUNTY, WASHINGTON.

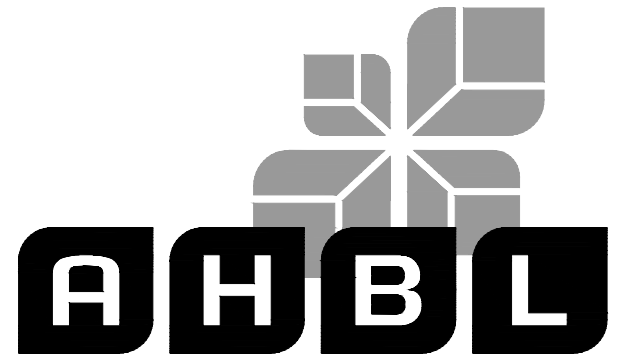

TACOMA · SEATTLE · SPOKANE · TRI-CITIES

2215 North 30th Street, Suite 300, Tacoma, WA 98403
253.383.2422 TEL. 253.383.2572 FAX www.ahbl.com WEB

Project Title:
LARSON RIVER ROAD STORAGE

Client:
LARSON AUTOMOTIVE GROUP

1409 ALEXANDER AVENUE EAST
FIFE, WA 98424-1109
JOSH LARSON

Job No.
2160102.10

Issue Set & Date:
PERMIT SET

06/15/2021



- NOTE:**
1. GEOTEXTILE MIRAFI 500 X OR APPROVED EQUAL SHALL BE PLACED UNDER THE ENTIRETY OF THE TEMPORARY ENTRANCE.
 2. ADDITIONAL ROCK SHALL BE ADDED PERIODICALLY TO MAINTAIN PROPER FUNCTION OF THE PAD.
 3. IF THE PAD DOES NOT ADEQUATELY REMOVE THE MUD FROM THE VEHICLE'S WHEELS, THE WHEELS SHALL BE HOSED OFF BEFORE THE VEHICLE ENTERS A PAVED STREET. THE WASHING SHALL BE DONE ON AN AREA COVERED WITH CRUSHED ROCK AND WASH WATER SHALL DRAIN TO A SEDIMENT RETENTION FACILITY OR THROUGH A SILT FENCE.

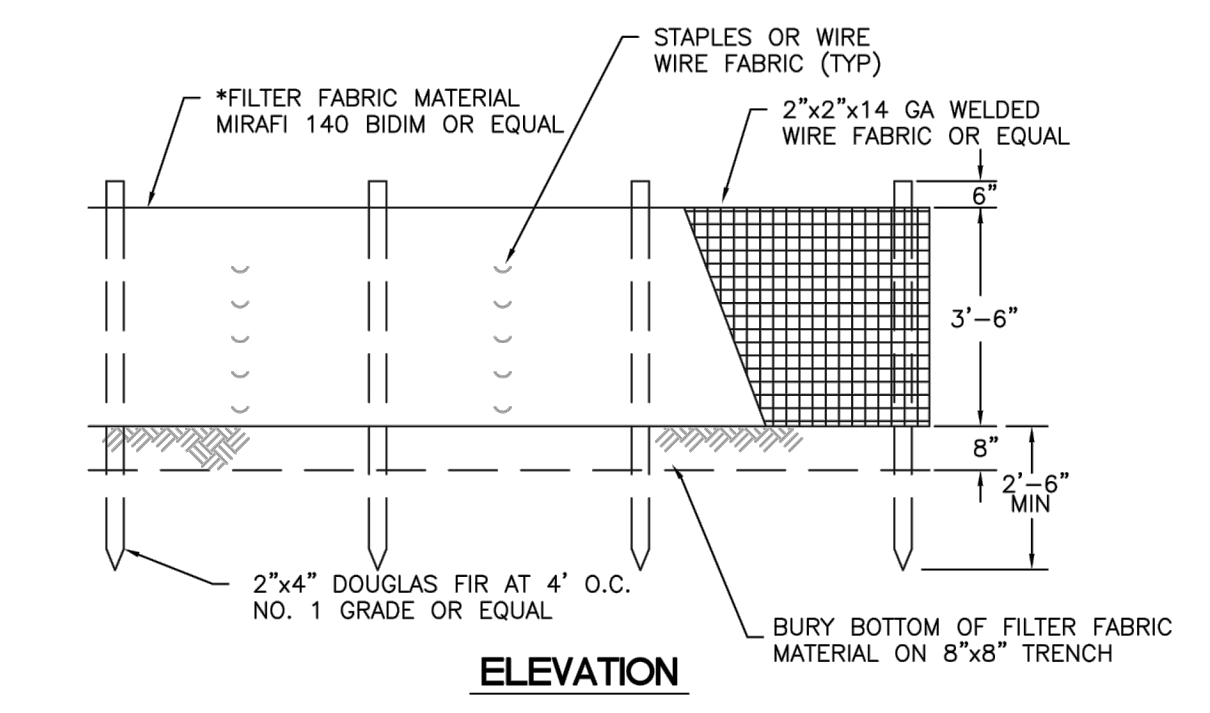
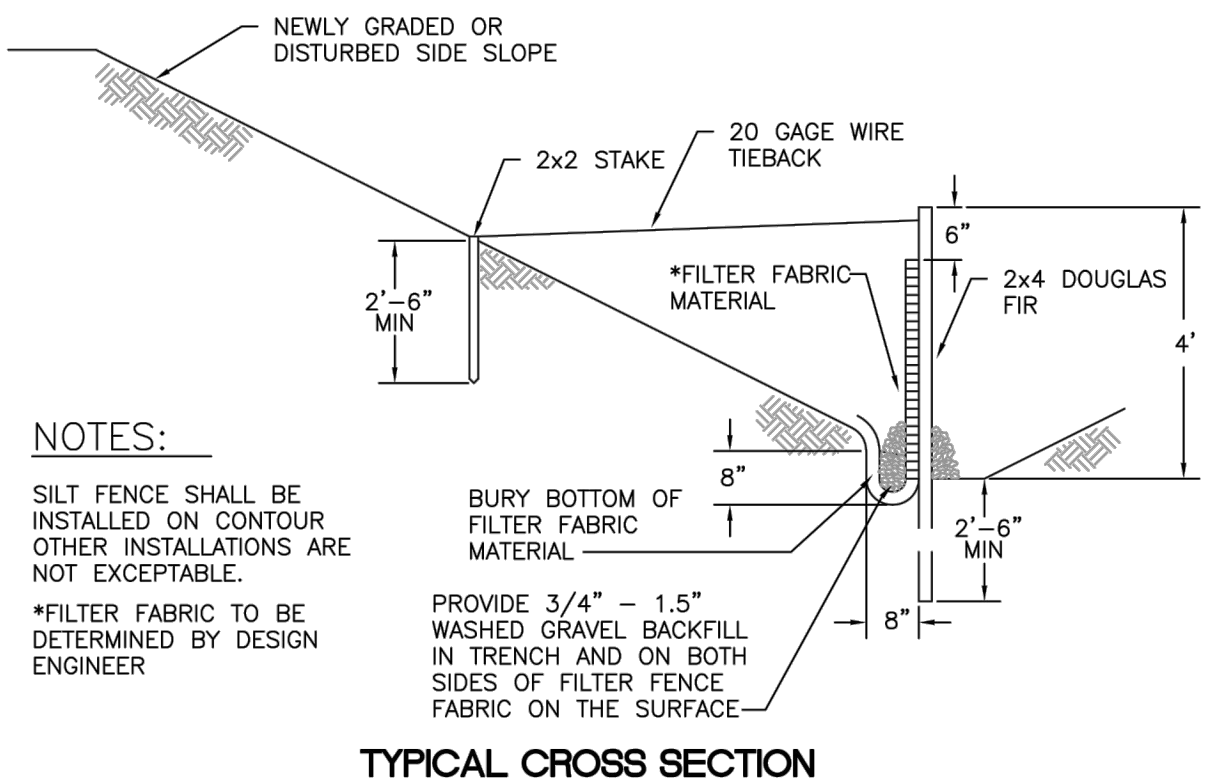
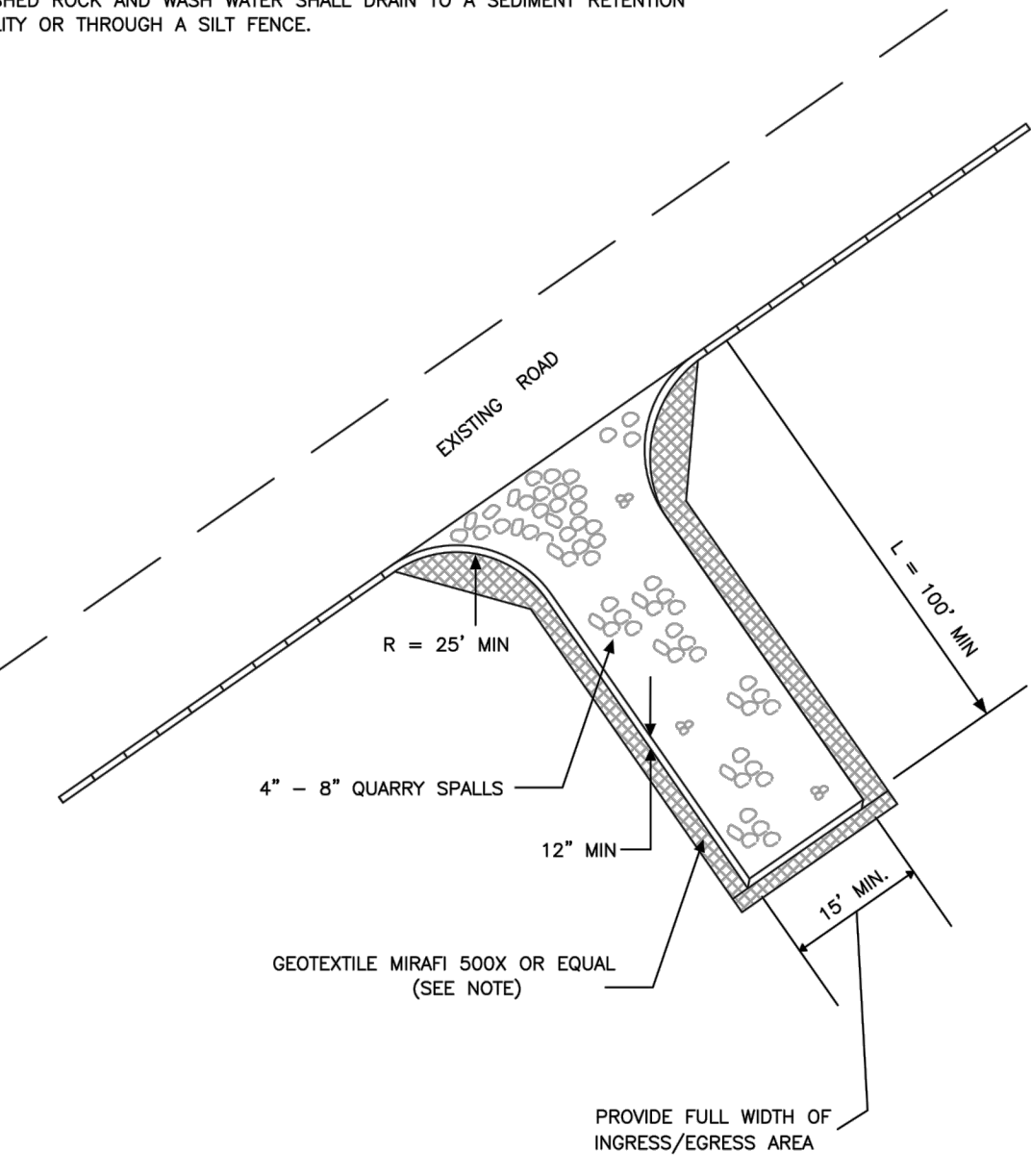

TESC NOTES

1. ALL LIMITS OF CLEARING AND AREAS OF VEGETATION PRESERVATION AS PRESCRIBED ON THESE PLANS SHALL BE CLEARLY FLAGGED IN THE FIELD AND OBSERVED DURING CONSTRUCTION.
2. ALL TEMPORARY SEDIMENTATION AND EROSION CONTROL MEASURES, AND PROTECTIVE MEASURES FOR CRITICAL AREAS AND SIGNIFICANT TREES SHALL BE INSTALLED PRIOR TO INITIATING ANY CONSTRUCTION ACTIVITIES.
3. ALL REQUIRED SEDIMENTATION AND EROSION CONTROL FACILITIES MUST BE CONSTRUCTED AND IN OPERATION PRIOR TO ANY LAND CLEARING AND/OR OTHER CONSTRUCTION ACTIVITIES TO ENSURE THAT SEDIMENT LADEN WATER DOES NOT ENTER ANY EXISTING DRAINAGE SYSTEM. THE CONTRACTOR SHALL SCHEDULE AN INSPECTION OF THE EROSION CONTROL FACILITIES PRIOR TO ANY LAND CLEARING AND/OR OTHER CONSTRUCTION. ALL EROSION AND SEDIMENT CONTROL FACILITIES SHALL BE MAINTAINED IN A SATISFACTORY CONDITION UNTIL SUCH TIME THAT CLEARING AND/OR CONSTRUCTION IS COMPLETED AND THE POTENTIAL FOR ON-SITE EROSION HAS PASSED. THE IMPLEMENTATION, MAINTENANCE, REPLACEMENT, AND ADDITIONS TO THE EROSION AND SEDIMENTATION CONTROL MEASURES SHALL BE THE RESPONSIBILITY OF THE CONTRACTOR.
4. THE EROSION AND SEDIMENTATION CONTROL SYSTEM MEASURES DEPICTED ON THESE PLANS ARE INTENDED TO BE MINIMUM REQUIREMENTS TO MEET ANTICIPATED SITE CONDITIONS. AS CONSTRUCTION PROGRESSES AND UNEXPECTED OR SEASONAL CONDITIONS DICTATE, ADDITIONAL MEASURES MAY BE NECESSARY TO ENSURE COMPLETE SILTATION CONTROL ON THE SITE. DURING THE COURSE OF CONSTRUCTION, IT SHALL BE THE OBLIGATION AND RESPONSIBILITY OF THE CONTRACTOR TO ADDRESS ANY NEW CONDITIONS THAT MAY BE CREATED BY CONSTRUCTION RELATED ACTIVITIES AND TO PROVIDE ADDITIONAL FACILITIES. OVER AND ABOVE THE MINIMUM REQUIREMENTS, AS MAY BE NEEDED TO PROTECT ADJACENT SITES, SENSITIVE AREAS, NATURAL WATER COURSES, AND/OR STORM DRAINAGE SYSTEMS.
5. ANY DISTURBED AREA WHICH HAS BEEN STRIPPED OF VEGETATION AND WHERE NO FURTHER WORK IS ANTICIPATED FOR A PERIOD OF 10 DAYS OR MORE DURING THE DRY SEASON (JULY 1-SEPT 30) OR 5 DAYS OR MORE IN THE WET SEASON (OCT 1-JUNE 30), SHALL BE IMMEDIATELY STABILIZED WITH MULCHING, GRASS PLANTING, OR OTHER APPROVED EROSION CONTROL TREATMENT APPLICABLE TO THE TIME OF YEAR IN QUESTION. GRASS SEEDING ALONE WILL BE ACCEPTABLE ONLY DURING THE MONTHS OF MAY THROUGH SEPTEMBER INCLUSIVE. SEEDING MAY PROCEED OUTSIDE THE SPECIFIED TIME PERIOD WHENEVER IT IS IN THE INTEREST OF THE CONTRACTOR BUT SHALL BE AUGMENTED WITH MULCHING, NETTING, OR OTHER TREATMENT.
6. NO TEMPORARY OR PERMANENT STOCKPILING OF MATERIALS OR EQUIPMENT SHALL OCCUR WITHIN CRITICAL AREAS OR ASSOCIATED BUFFERS, OR THE CRITICAL ROOT ZONE FOR VEGETATION PROPOSED FOR RETENTION.
7. WATER SITE AS NECESSARY TO CONTROL DUST.
8. TOPSOIL SHALL NOT BE PLACED WHILE SUBGRADE IS IN A FROZEN OR MUDDY CONDITION, WHEN THE SUBGRADE IS EXCESSIVELY WET, OR WHEN CONDITIONS EXIST THAT MAY OTHERWISE BE DETRIMENTAL TO PROPER GRADING OR PROPOSED SODDING OR SEEDING.
9. ON-SITE EROSION CONTROL MEASURES SHALL BE THE RESPONSIBILITY OF THE CONTRACTOR. ANY PROBLEMS OCCURRING BEFORE FINAL STABILIZATION OF THE SITE SHALL BE CORRECTED BY THE CONTRACTOR.
10. IF EROSION OR SEDIMENTATION OCCURS ON ADJACENT SITES, ALL CONSTRUCTION WORK WITHIN THE PROJECT LIMITS THAT WILL AGGRAVATE THE SITUATION MUST CEASE AND THE CONTRACTOR SHALL IMMEDIATELY COMMENCE RESTORATION OR MITIGATION MEASURES. RESTORATION ACTIVITY SHALL CONTINUE UNTIL SUCH TIME AS THE PROBLEM IS RECTIFIED.
11. ALL EROSION AND SEDIMENTATION CONTROL MEASURES SHOWN ON THESE DRAWINGS SHALL BE INSTALLED PRIOR TO, OR AS THE FIRST STAGE OF SITE PREPARATION.
12. SHOULD THE TEMPORARY EROSION AND SEDIMENTATION CONTROL MEASURES SHOWN ON THESE DRAWINGS NOT PROVE ADEQUATE TO CONTROL EROSION AND SEDIMENTATION, THE CONTRACTOR SHALL INSTALL ADDITIONAL FACILITIES AS NECESSARY TO PROTECT ADJACENT SITES, SENSITIVE AREAS, NATURAL WATER COURSES, AND/OR STORM DRAINAGE SYSTEMS.
13. ALL WORK ASSOCIATED WITH STABILIZING THE DISTURBED AREAS SHALL BE IN ACCORDANCE WITH THE 2012 WESTERN WASHINGTON DOE MANUAL.
14. ALL NECESSARY FACILITIES SHALL BE MAINTAINED ON SITE TO PREVENT DEBRIS, DUST, AND MUD FROM ACCUMULATING ON ADJACENT ROADWAYS.
15. THE CONTRACTOR SHALL BE REQUIRED TO CALL 1-800-424-5555 OR '811' A MINIMUM OF TWO WORKING DAYS PRIOR TO COMMENCING ANY EXCAVATION ACTIVITIES TO DETERMINE FIELD LOCATIONS OF ALL UNDERGROUND UTILITIES.
16. RUNOFF SHALL NOT BE ALLOWED TO DRAIN INTO THE STORM DRAINAGE SYSTEM DURING CONSTRUCTION. PROVIDE TEMPORARY PROTECTION FOR YARD DRAINS AS REQUIRED TO PREVENT RUNOFF FROM ENTERING THE STORM DRAINAGE SYSTEM.
17. INSTALL INLET PROTECTION IN ALL EXISTING CATCH BASINS WITHIN 300 FEET DOWNSTREAM OF THE PROJECT. INSTALL CATCH BASIN INLET PROTECTION IN ALL NEW CATCH BASINS AS SOON AS THEY ARE INSTALLED.
18. MAINTAIN EXISTING ASPHALT TO THE MAXIMUM EXTENT AND DURATION POSSIBLE TO PREVENT EROSION AND SEDIMENT TRACKING OFFSITE. PROVIDE CONSTRUCTION ENTRANCE IF ASPHALT CANNOT BE MAINTAINED.

CITY OF PUYALLUP
DEVELOPMENT ENGINEERING and PUBLIC WORKS DEPARTMENTS

TEMPORARY CONSTRUCTION ENTRANCE

DESIGNED BY: JIM IRWIN-SVORODA	CHECKED BY: LINDA LIAN	APPROVED BY: COLLEEN HARRIS	DATE: 05.01.01
FILE NAME: P:\PROJECTS\0608\STDCITY\200905_0206\05.01.01	DATE APPROVED: 05/01/01	DATE REVISION: 05/01/01	SCALE: 1/4\"/>

CITY OF PUYALLUP
DEVELOPMENT ENGINEERING and PUBLIC WORKS DEPARTMENTS

SILTATION FENCE

DESIGNED BY: LINDA LIAN	CHECKED BY: LINDA LIAN	APPROVED BY: COLLEEN HARRIS	DATE: 02.03.02
FILE NAME: P:\PROJECTS\0608\STDCITY\200905_0206\02.03.02	DATE APPROVED: 02/03/02	DATE REVISION: 02/03/02	SCALE: 1/4\"/>

1 CONSTRUCTION ENTRANCE NOT TO SCALE

2 SILT FENCE NOT TO SCALE

CITY OF PUYALLUP CONSTRUCTION NOTES

1. ALL LIMITS OF CLEARING AND AREAS OF VEGETATION PRESERVATION AS PRESCRIBED ON THE PLANS SHALL BE CLEARLY FLAGGED IN THE FIELD AND OBSERVED DURING CONSTRUCTION.
2. ALL REQUIRED SEDIMENTATION AND EROSION CONTROL FACILITIES MUST BE CONSTRUCTED AND IN OPERATION PRIOR TO ANY LAND CLEARING AND/OR OTHER CONSTRUCTION TO ENSURE THAT SEDIMENT LADEN WATER DOES NOT ENTER THE NATURAL DRAINAGE SYSTEM. THE CONTRACTOR SHALL SCHEDULE AN INSPECTION OF THE EROSION CONTROL FACILITIES PRIOR TO ANY LAND CLEARING AND/OR CONSTRUCTION. ALL EROSION AND SEDIMENT FACILITIES SHALL BE MAINTAINED IN A SATISFACTORY CONDITION AS DETERMINED BY THE CITY, UNTIL SUCH TIME THAT CLEARING AND/OR CONSTRUCTION IS COMPLETED AND THE POTENTIAL FOR ON-SITE EROSION HAS PASSED. THE IMPLEMENTATION, MAINTENANCE, REPLACEMENT, AND ADDITIONS TO THE EROSION AND SEDIMENTATION CONTROL SYSTEMS SHALL BE THE RESPONSIBILITY OF THE PERMITEE.
3. THE EROSION AND SEDIMENTATION CONTROL SYSTEM FACILITIES DEPICTED ON THESE PLANS ARE INTENDED TO BE MINIMUM REQUIREMENTS TO MEET ANTICIPATED SITE CONDITIONS. AS CONSTRUCTION PROGRESSES AND UNEXPECTED OR SEASONAL CONDITIONS DICTATE, FACILITIES WILL BE NECESSARY TO ENSURE COMPLETE SILTATION CONTROL ON THE SITE. DURING THE COURSE OF CONSTRUCTION, IT SHALL BE THE OBLIGATION AND RESPONSIBILITY OF THE PERMITEE TO ADDRESS AND NEW CONDITIONS THAT MAY BE CREATED BY HIS ACTIVITIES AND TO PROVIDE ADDITIONAL FACILITIES. OVER AND ABOVE THE MINIMUM REQUIREMENTS, AS MAY BE NEEDED TO PROTECT ADJACENT PROPERTIES, SENSITIVE AREAS, NATURAL WATER COURSES, AND/OR STORM DRAINAGE SYSTEMS.
4. APPROVAL OF THESE PLANS IS FOR GRADING TEMPORARY DRAINAGE, EROSION, AND SEDIMENTATION CONTROL ONLY. IT DOES NOT CONSTITUTE AND APPROVAL OF PERMANENT STORM DRAINAGE DESIGN, SIZE, OR LOCATION OF PIPES, RESTRICTORS, CHANNELS, OR RETENTION FACILITIES.
5. ANY DISTURBED AREA WHICH HAS BEEN STRIPPED OF VEGETATION AND WHERE NO FURTHER WORKS IS ANTICIPATED FOR A PERIOD OF 30 DAYS OR MORE, MUST BE IMMEDIATELY STABILIZED WITH MULCHING, GRASS PLANTING, OR OTHER APPROVED EROSION CONTROL TREATMENT APPLICABLE TO THE TIME OF YEAR IN QUESTION. GRASS SEEDING ALONE WILL BE ACCEPTABLE ONLY DURING THE MONTHS OF APRIL THROUGH SEPTEMBER INCLUSIVE. SEEDING MAY PROCEED OUTSIDE THE SPECIFIED TIME PERIOD WHENEVER IT IS IN THE INTEREST OF THE PERMITEE BUT MUST BE AUGMENTED WITH MULCHING, NETTING, OR OTHER TREATMENT APPROVED BY THE CITY.
6. IN CASE EROSION OR SEDIMENTATION OCCUR TO ADJACENT PROPERTIES, ALL CONSTRUCTION WORK WITHIN THE DEVELOPMENT THAT WILL FURTHER AGGRAVATE THE SITUATION MUST CEASE, AND THE OWNER/CONTRACTOR WILL IMMEDIATELY COMMENCE RESTORATION METHODS. RESTORATION ACTIVITY WILL CONTINUE UNTIL SUCH TIME AS THE AFFECTED PROPERTY OWNER IS SATISFIED.
7. NO TEMPORARY OR PERMANENT STOCKPILING OF MATERIALS OR EQUIPMENT SHALL OCCUR WITHIN CRITICAL AREAS OR ASSOCIATED BUFFERS, OR THE CRITICAL ROOT ZONE FOR VEGETATION PROPOSED FOR RETENTION.

NOTICE
ALTERATION OF THIS DOCUMENT SHALL INVALIDATE THE PROFESSIONAL SEAL AND SIGNATURE. PRODUCTION OF THIS DOCUMENT DOES NOT CONSTITUTE A WAIVER OF THE PROFESSIONAL ENGINEER'S LIABILITY. THIS DOCUMENT IS FOR THE PROJECT IDENTIFIED IN THE TITLE BLOCK AND IS NOT TO BE USED FOR ANY OTHER PROJECT, OR ADDITION TO THAT PROJECT OR FOR ANY OTHER PROJECT.

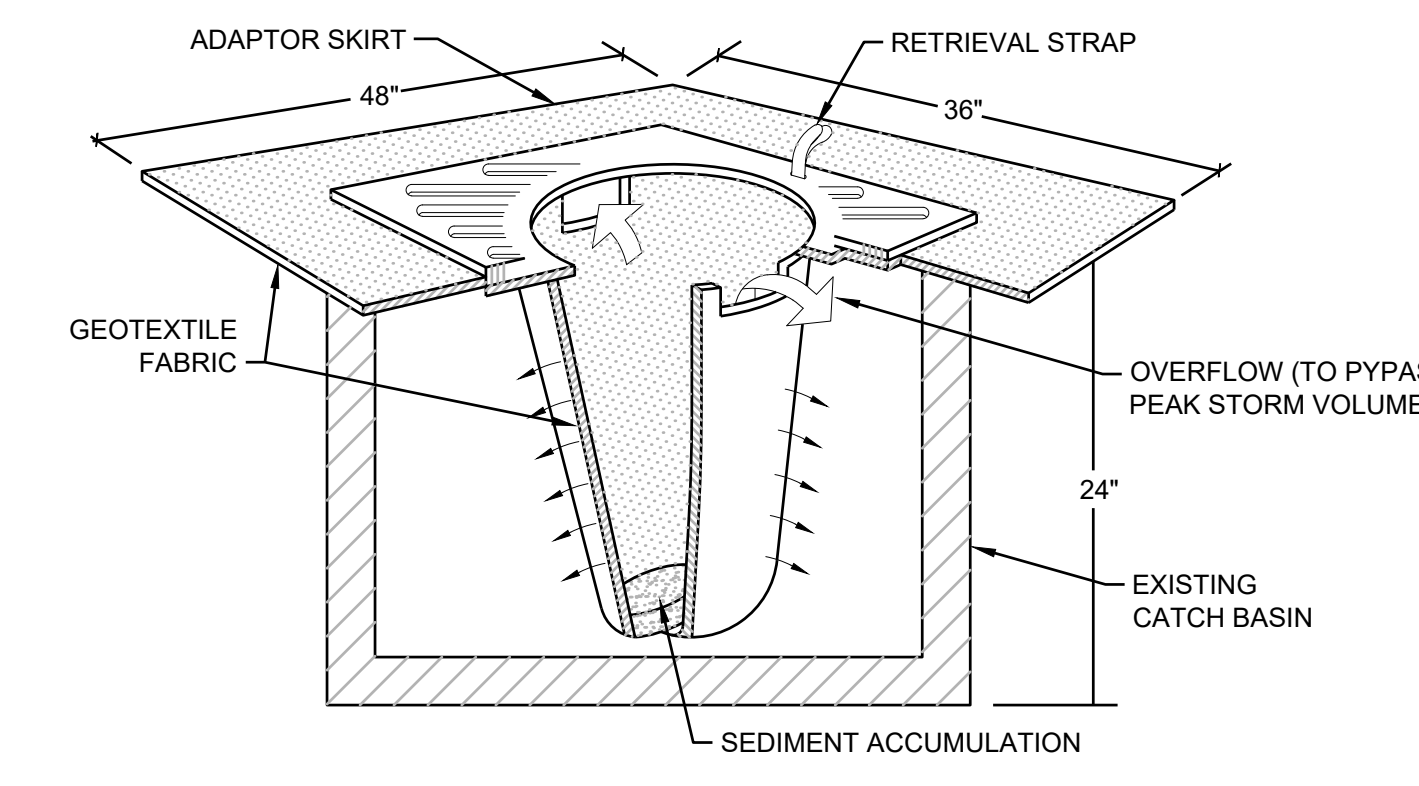

- NOTES:**
1. FILTERS SHALL BE INSPECTED AFTER EACH STORM EVENT AND CLEANED OR REPLACED WHEN 1/3 FULL.
 2. INSTALL INLET PROTECTION IN ALL NEW STORM STRUCTURES THAT WILL COLLECT STORMWATER AS THEY ARE INSTALLED.

3 INLET PROTECTION NOT TO SCALE



Know what's below.
Call before you dig.

APPROVED

BY: CITY OF PUYALLUP
ENGINEERING SERVICES

DATE: _____

NOTE: THIS APPROVAL IS VOID AFTER 1 YEAR FROM APPROVAL DATE. THE CITY WILL NOT BE RESPONSIBLE FOR ERRORS AND/OR OMISSIONS ON THESE PLANS. FIELD CONDITIONS MAY DICTATE CHANGES TO THESE PLANS AS DETERMINED BY THE ENGINEERING SERVICES MANAGER.

Revisions:

Sheet Title:
NOTES AND DETAILS

Designed by: MH
Drawn by: SBK
Checked by: TCS

Sheet No.
C1.2
VALUEof 11 Sheets

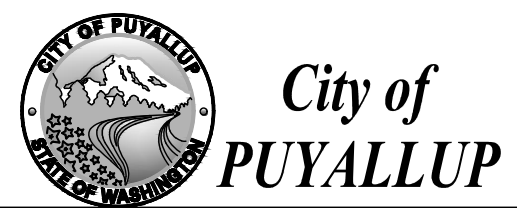

Exhibit 2

Inspection Logs

Larson River Road Storage
Stormwater Pollution Prevention Plan
Inspection and Maintenance Report Form

To be completed every 7 days and within 24 hours of a rainfall event of 0.5 inches or more

Inspector: _____ Date: _____
 Inspector's Qualifications: _____

Days since last rainfall: _____ Amount of last rainfall: _____ inches

Stabilization Measures

Drainage Area	Date Since Last Disturbance	Date of Next Disturbance	Stabilized (yes/No)	Stabilized With	Condition

Stabilization required: _____

To be performed by: _____ On or before: _____



Larson River Road Storage
Stormwater Pollution Prevention Plan
Inspection and Maintenance Report Form

Site Entrance:

Date:

Temporary Construction Entrance

Drainage Area Perimeter	Does Rock Pad Adequately Remove Mud from Vehicle Wheels?	Is Rock Pad Clogged with Mud?	Have Quarry Spalls Been Moved to the Roadway?

Maintenance required for temporary construction entrances:

To be performed by: _____ On or before: _____

Larson River Road Storage
Stormwater Pollution Prevention Plan
Inspection and Maintenance Report Form

Perimeter Structural Controls:

Date:

Silt Fence

Drainage Area Perimeter	Has Silt Reached 1/3 of Fence Height?	Is Fence Properly Secured?	Is There Evidence of Washout or Overtopping?

Maintenance required for silt fence and straw bales:

To be performed by: _____ On or before: _____

Larson River Road Storage
Stormwater Pollution Prevention Plan
Inspection and Maintenance Report Form

Inlet Protection:

Date:

Storm Drain Barriers

Inlet	Has Silt Reached 1/3 of Barrier Height?	Is Barrier Properly Secured?	Is There Evidence of Washout or Overtopping?

Maintenance required for storm drain barriers:

To be performed by: _____ On or before: _____

Larson River Road Storage
Stormwater Pollution Prevention Plan
Inspection and Maintenance Report Form

Changes required to the pollution prevention plan:

Reasons for changes:

I certify under penalty of law that this document and all attachments were prepared under my direction or supervision in accordance with a system designed to assure that qualified personnel properly gathered and evaluated the information submitted. Based on my inquiry of the person or persons who manage the system, or those persons directly responsible for gathering the information, the information submitted is, to the best of my knowledge and belief, true, accurate, and complete. I am aware that there are significant penalties for submitting false information, including the possibility of fine and imprisonment for knowing violations.

Signature: _____ Date: _____

Exhibit 3

Best Management Practices (BMPs)

BMP C105.....	Stabilized Construction Entrance
BMP C120.....	Temporary and Permanent Seeding
BMP C121.....	Mulching
BMP C123.....	Plastic Covering
BMP C140.....	Dust Control
BMP C151.....	Concrete Handling
BMP C152.....	Sawcutting and Surface Pollution Prevention
BMP C160.....	Certified Erosion and Sediment Control Lead
BMP C220.....	Storm Drain Inlet Protection
BMP C233.....	Silt Fence

BMP C105: Stabilized Construction Entrance

Purpose Construction entrances are stabilized to reduce the amount of sediment transported onto paved roads by vehicles or equipment by constructing a stabilized pad of quarry spalls at entrances to construction sites.

Conditions of Use Construction entrances shall be stabilized wherever traffic will be leaving a construction site and traveling on paved roads or other paved areas within 1,000 feet of the site.

On large commercial, highway, and road projects, the designer should include enough extra materials in the contract to allow for additional stabilized entrances not shown in the initial Construction SWPPP. It is difficult to determine exactly where access to these projects will take place; additional materials will enable the contractor to install them where needed.

Design and Installation Specifications

- See Figure 4.2 for details. Note: the 100' minimum length of the entrance shall be reduced to the maximum practicable size when the size or configuration of the site does not allow the full length (100').
- A separation geotextile shall be placed under the spalls to prevent fine sediment from pumping up into the rock pad. The geotextile shall meet the following standards:

Grab Tensile Strength (ASTM D4751)	200 psi min.
Grab Tensile Elongation (ASTM D4632)	30% max.
Mullen Burst Strength (ASTM D3786-80a)	400 psi min.
AOS (ASTM D4751)	20-45 (U.S. standard sieve size)

- Consider early installation of the first lift of asphalt in areas that will paved; this can be used as a stabilized entrance. Also consider the installation of excess concrete as a stabilized entrance. During large concrete pours, excess concrete is often available for this purpose.
- Hog fuel (wood-based mulch) may be substituted for or combined with quarry spalls in areas that will not be used for permanent roads. Hog fuel is generally less effective at stabilizing construction entrances and should be used only at sites where the amount of traffic is very limited. Hog fuel is not recommended for entrance stabilization in urban areas. The effectiveness of hog fuel is highly variable and it generally requires more maintenance than quarry spalls. The inspector may at any time require the use of quarry spalls if the hog fuel is not preventing sediment from being tracked onto pavement or if the hog fuel is being carried onto pavement. Hog fuel is prohibited in permanent roadbeds because organics in the subgrade soils cause degradation of the subgrade support over time.
- Fencing (see BMPs C103 and C104) shall be installed as necessary to restrict traffic to the construction entrance.

Maintenance Standards

- Whenever possible, the entrance shall be constructed on a firm, compacted subgrade. This can substantially increase the effectiveness of the pad and reduce the need for maintenance.
- Quarry spalls (or hog fuel) shall be added if the pad is no longer in accordance with the specifications.
- If the entrance is not preventing sediment from being tracked onto pavement, then alternative measures to keep the streets free of sediment shall be used. This may include street sweeping, an increase in the dimensions of the entrance, or the installation of a wheel wash.
- Any sediment that is tracked onto pavement shall be removed by shoveling or street sweeping. The sediment collected by sweeping shall be removed or stabilized on site. The pavement shall not be cleaned by washing down the street, except when sweeping is ineffective and there is a threat to public safety. If it is necessary to wash the streets, the construction of a small sump shall be considered. The sediment would then be washed into the sump where it can be controlled.
- Any quarry spalls that are loosened from the pad, which end up on the roadway shall be removed immediately.
- If vehicles are entering or exiting the site at points other than the construction entrance(s), fencing (see BMPs C103 and C104) shall be installed to control traffic.
- Upon project completion and site stabilization, all construction accesses intended as permanent access for maintenance shall be permanently stabilized.

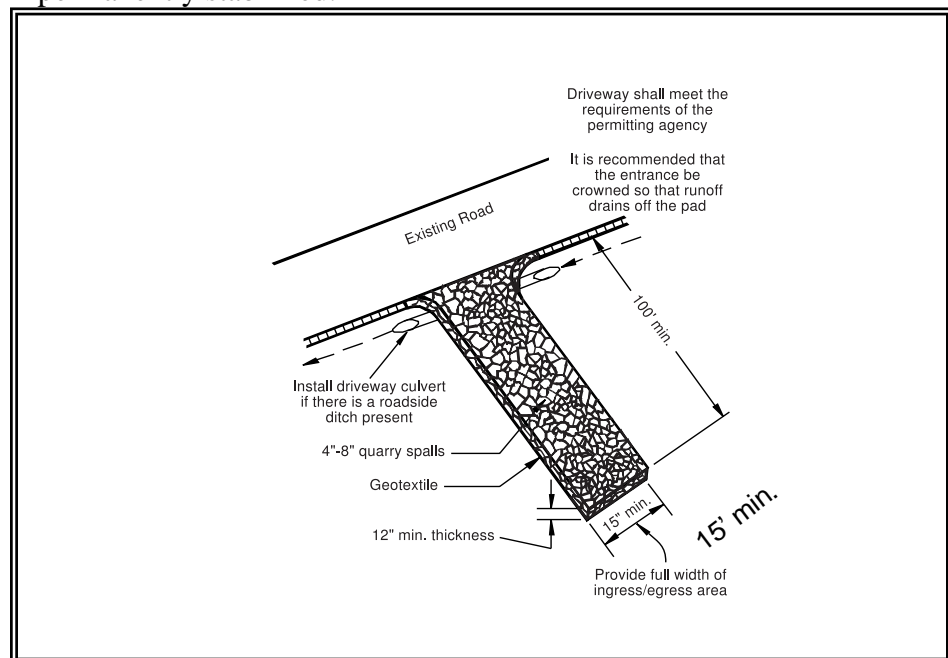

Figure 4.2 – Stabilized Construction Entrance

BMP C120: Temporary and Permanent Seeding

Purpose

Seeding is intended to reduce erosion by stabilizing exposed soils. A well-established vegetative cover is one of the most effective methods of reducing erosion.

Conditions of Use

- Seeding may be used throughout the project on disturbed areas that have reached final grade or that will remain unworked for more than 30 days.
- Channels that will be vegetated should be installed before major earthwork and hydroseeded with a Bonded Fiber Matrix. The vegetation should be well established (i.e., 75 percent cover) before water is allowed to flow in the ditch. With channels that will have high flows, erosion control blankets should be installed over the hydroseed. If vegetation cannot be established from seed before water is allowed in the ditch, sod should be installed in the bottom of the ditch over hydromulch and blankets.
- Retention/detention ponds should be seeded as required.
- Mulch is required at all times because it protects seeds from heat, moisture loss, and transport due to runoff.
- All disturbed areas shall be reviewed in late August to early September and all seeding should be completed by the end of September. Otherwise, vegetation will not establish itself enough to provide more than average protection.
- At final site stabilization, all disturbed areas not otherwise vegetated or stabilized shall be seeded and mulched. Final stabilization means the completion of all soil disturbing activities at the site and the establishment of a permanent vegetative cover, or equivalent permanent stabilization measures (such as pavement, riprap, gabions or geotextiles) which will prevent erosion.

Design and Installation Specifications

- Seeding should be done during those seasons most conducive to growth and will vary with the climate conditions of the region. Local experience should be used to determine the appropriate seeding periods.
- The optimum seeding windows for western Washington are April 1 through June 30 and September 1 through October 1. Seeding that occurs between July 1 and August 30 will require irrigation until 75 percent grass cover is established. Seeding that occurs between October 1 and March 30 will require a mulch or plastic cover until 75 percent grass cover is established.
- To prevent seed from being washed away, confirm that all required surface water control measures have been installed.

- The seedbed should be firm and rough. All soil should be roughened no matter what the slope. If compaction is required for engineering purposes, slopes must be track walked before seeding. Backblading or smoothing of slopes greater than 4:1 is not allowed if they are to be seeded.
- New and more effective restoration-based landscape practices rely on deeper incorporation than that provided by a simple single-pass rototilling treatment. Wherever practical the subgrade should be initially ripped to improve long-term permeability, infiltration, and water inflow qualities. At a minimum, permanent areas shall use soil amendments to achieve organic matter and permeability performance defined in engineered soil/landscape systems. For systems that are deeper than 8 inches the rototilling process should be done in multiple lifts, or the prepared soil system shall be prepared properly and then placed to achieve the specified depth.
- Organic matter is the most appropriate form of “fertilizer” because it provides nutrients (including nitrogen, phosphorus, and potassium) in the least water-soluble form. A natural system typically releases 2-10 percent of its nutrients annually. Chemical fertilizers have since been formulated to simulate what organic matter does naturally.
- In general, 10-4-6 N-P-K (nitrogen-phosphorus-potassium) fertilizer can be used at a rate of 90 pounds per acre. Slow-release fertilizers should always be used because they are more efficient and have fewer environmental impacts. It is recommended that areas being seeded for final landscaping conduct soil tests to determine the exact type and quantity of fertilizer needed. This will prevent the over-application of fertilizer. Fertilizer should not be added to the hydromulch machine and agitated more than 20 minutes before it is to be used. If agitated too much, the slow-release coating is destroyed.
- There are numerous products available on the market that take the place of chemical fertilizers. These include several with seaweed extracts that are beneficial to soil microbes and organisms. If 100 percent cottonseed meal is used as the mulch in hydroseed, chemical fertilizer may not be necessary. Cottonseed meal is a good source of long-term, slow-release, available nitrogen.
- Hydroseed applications shall include a minimum of 1,500 pounds per acre of mulch with 3 percent tackifier. Mulch may be made up of 100 percent: cottonseed meal; fibers made of wood, recycled cellulose, hemp, and kenaf; compost; or blends of these. Tackifier shall be plant-based, such as guar or alpha plantago, or chemical-based such as polyacrylamide or polymers. Any mulch or tackifier product used shall be installed per manufacturer’s instructions. Generally, mulches come in 40-50 pound bags. Seed and fertilizer are added at time of application.

- Mulch is always required for seeding. Mulch can be applied on top of the seed or simultaneously by hydroseeding.
- On steep slopes, Bonded Fiber Matrix (BFM) or Mechanically Bonded Fiber Matrix (MBFM) products should be used. BFM/MBFM products are applied at a minimum rate of 3,000 pounds per acre of mulch with approximately 10 percent tackifier. Application is made so that a minimum of 95 percent soil coverage is achieved. Numerous products are available commercially and should be installed per manufacturer's instructions. Most products require 24-36 hours to cure before a rainfall and cannot be installed on wet or saturated soils. Generally, these products come in 40-50 pound bags and include all necessary ingredients except for seed and fertilizer.

BFMs and MBFMs have some advantages over blankets:

- No surface preparation required;
- Can be installed via helicopter in remote areas;
- On slopes steeper than 2.5:1, blanket installers may need to be roped and harnessed for safety;
- They are at least \$1,000 per acre cheaper installed.

In most cases, the shear strength of blankets is not a factor when used on slopes, only when used in channels. BFMs and MBFMs are good alternatives to blankets in most situations where vegetation establishment is the goal.

- When installing seed via hydroseeding operations, only about 1/3 of the seed actually ends up in contact with the soil surface. This reduces the ability to establish a good stand of grass quickly. One way to overcome this is to increase seed quantities by up to 50 percent.
- Vegetation establishment can also be enhanced by dividing the hydromulch operation into two phases:
 1. Phase 1- Install all seed and fertilizer with 25-30 percent mulch and tackifier onto soil in the first lift;
 2. Phase 2- Install the rest of the mulch and tackifier over the first lift.

An alternative is to install the mulch, seed, fertilizer, and tackifier in one lift. Then, spread or blow straw over the top of the hydromulch at a rate of about 800-1000 pounds per acre. Hold straw in place with a standard tackifier. Both of these approaches will increase cost moderately but will greatly improve and enhance vegetative establishment. The increased cost may be offset by the reduced need for:

1. Irrigation
2. Reapplication of mulch
3. Repair of failed slope surfaces

This technique works with standard hydromulch (1,500 pounds per acre minimum) and BFM/MBFMs (3,000 pounds per acre minimum).

- Areas to be permanently landscaped shall provide a healthy topsoil that reduces the need for fertilizers, improves overall topsoil quality, provides for better vegetal health and vitality, improves hydrologic characteristics, and reduces the need for irrigation. This can be accomplished in a number of ways:

Recent research has shown that the best method to improve till soils is to amend these soils with compost. The optimum mixture is approximately two parts soil to one part compost. This equates to 4 inches of compost mixed to a depth of 12 inches in till soils. Increasing the concentration of compost beyond this level can have negative effects on vegetal health, while decreasing the concentrations can reduce the benefits of amended soils. Please note: The compost should meet specifications for Grade A quality compost in Ecology Publication 94-038.

Other soils, such as gravel or cobble outwash soils, may require different approaches. Organics and fines easily migrate through the loose structure of these soils. Therefore, the importation of at least 6 inches of quality topsoil, underlain by some type of filter fabric to prevent the migration of fines, may be more appropriate for these soils.

Areas that already have good topsoil, such as undisturbed areas, do not require soil amendments.

- Areas that will be seeded only and not landscaped may need compost or meal-based mulch included in the hydroseed in order to establish vegetation. Native topsoil should be re-installed on the disturbed soil surface before application.
- Seed that is installed as a temporary measure may be installed by hand if it will be covered by straw, mulch, or topsoil. Seed that is installed as a permanent measure may be installed by hand on small areas (usually less than 1 acre) that will be covered with mulch, topsoil, or erosion blankets. The seed mixes listed below include recommended mixes for both temporary and permanent seeding. These mixes, with the exception of the wetland mix, shall be applied at a rate of 120 pounds per acre. This rate can be reduced if soil amendments or slow-release fertilizers are used. Local suppliers or the local conservation district should be consulted for their recommendations because the appropriate mix depends on a variety of factors, including location, exposure, soil type, slope, and expected foot traffic. Alternative seed mixes approved by the local authority may be used.

Table 4.1 represents the standard mix for those areas where just a temporary vegetative cover is required.

Table 4.1 Temporary Erosion Control Seed Mix			
	% Weight	% Purity	% Germination
Chewings or annual blue grass <i>Festuca rubra var. commutata</i> or <i>Poa anna</i>	40	98	90
Perennial rye - <i>Lolium perenne</i>	50	98	90
Redtop or colonial bentgrass <i>Agrostis alba</i> or <i>Agrostis tenuis</i>	5	92	85
White dutch clover <i>Trifolium repens</i>	5	98	90

Table 4.2 provides just one recommended possibility for landscaping seed.

Table 4.2 Landscaping Seed Mix			
	% Weight	% Purity	% Germination
Perennial rye blend <i>Lolium perenne</i>	70	98	90
Chewings and red fescue blend <i>Festuca rubra var. commutata</i> or <i>Festuca rubra</i>	30	98	90

This turf seed mix in Table 4.3 is for dry situations where there is no need for much water. The advantage is that this mix requires very little maintenance.

Table 4.3 Low-Growing Turf Seed Mix			
	% Weight	% Purity	% Germination
Dwarf tall fescue (several varieties) <i>Festuca arundinacea var.</i>	45	98	90
Dwarf perennial rye (Barclay) <i>Lolium perenne var. barclay</i>	30	98	90
Red fescue <i>Festuca rubra</i>	20	98	90
Colonial bentgrass <i>Agrostis tenuis</i>	5	98	90

Table 4.4 presents a mix recommended for bioswales and other intermittently wet areas.

Table 4.4 Bioswale Seed Mix*			
	% Weight	% Purity	% Germination
Tall or meadow fescue <i>Festuca arundinacea</i> or <i>Festuca elatior</i>	75-80	98	90
Seaside/Creeping bentgrass <i>Agrostis palustris</i>	10-15	92	85
Redtop bentgrass <i>Agrostis alba</i> or <i>Agrostis gigantea</i>	5-10	90	80

* Modified Briargreen, Inc. Hydroseeding Guide Wetlands Seed Mix

The seed mix shown in Table 4.5 is a recommended low-growing, relatively non-invasive seed mix appropriate for very wet areas that are not regulated wetlands. Other mixes may be appropriate, depending on the soil type and hydrology of the area. Recent research suggests that bentgrass (*agrostis* sp.) should be emphasized in wet-area seed mixes. Apply this mixture at a rate of 60 pounds per acre.

Table 4.5 Wet Area Seed Mix*			
	% Weight	% Purity	% Germination
Tall or meadow fescue <i>Festuca arundinacea</i> or <i>Festuca elatior</i>	60-70	98	90
Seaside/Creeping bentgrass <i>Agrostis palustris</i>	10-15	98	85
Meadow foxtail <i>Alepcurus pratensis</i>	10-15	90	80
Alsike clover <i>Trifolium hybridum</i>	1-6	98	90
Redtop bentgrass <i>Agrostis alba</i>	1-6	92	85

* Modified Briargreen, Inc. Hydroseeding Guide Wetlands Seed Mix

The meadow seed mix in Table 4.6 is recommended for areas that will be maintained infrequently or not at all and where colonization by native plants is desirable. Likely applications include rural road and utility right-of-way. Seeding should take place in September or very early October in order to obtain adequate establishment prior to the winter months. The appropriateness of clover in the mix may need to be considered, as this can be a fairly invasive species. If the soil is amended, the addition of clover may not be necessary.

Table 4.6 Meadow Seed Mix			
	% Weight	% Purity	% Germination
Redtop or Oregon bentgrass <i>Agrostis alba</i> or <i>Agrostis oregonensis</i>	20	92	85
Red fescue <i>Festuca rubra</i>	70	98	90
White dutch clover <i>Trifolium repens</i>	10	98	90

Maintenance Standards

- Any seeded areas that fail to establish at least 80 percent cover (100 percent cover for areas that receive sheet or concentrated flows) shall be reseeded. If reseeding is ineffective, an alternate method, such as sodding, mulching, or nets/blankets, shall be used. If winter weather prevents adequate grass growth, this time limit may be relaxed at the discretion of the local authority when sensitive areas would otherwise be protected.

- After adequate cover is achieved, any areas that experience erosion shall be reseeded and protected by mulch. If the erosion problem is drainage related, the problem shall be fixed and the eroded area reseeded and protected by mulch.
- Seeded areas shall be supplied with adequate moisture, but not watered to the extent that it causes runoff.

BMP C121: Mulching

Purpose

The purpose of mulching soils is to provide immediate temporary protection from erosion. Mulch also enhances plant establishment by conserving moisture, holding fertilizer, seed, and topsoil in place, and moderating soil temperatures. There is an enormous variety of mulches that can be used. Only the most common types are discussed in this section.

Conditions of Use

As a temporary cover measure, mulch should be used:

- On disturbed areas that require cover measures for less than 30 days.
- As a cover for seed during the wet season and during the hot summer months.
- During the wet season on slopes steeper than 3H:1V with more than 10 feet of vertical relief.
- Mulch may be applied at any time of the year and must be refreshed periodically.

Design and Installation Specifications

For mulch materials, application rates, and specifications, see Table 4.7. Note: Thicknesses may be increased for disturbed areas in or near sensitive areas or other areas highly susceptible to erosion.

Mulch used within the ordinary high-water mark of surface waters should be selected to minimize potential flotation of organic matter. Composted organic materials have higher specific gravities (densities) than straw, wood, or chipped material.

Maintenance Standards

- The thickness of the cover must be maintained.
- Any areas that experience erosion shall be remulched and/or protected with a net or blanket. If the erosion problem is drainage related, then the problem shall be fixed and the eroded area remulched.

**Table 4.7
Mulch Standards and Guidelines**

Mulch Material	Quality Standards	Application Rates	Remarks
Straw	Air-dried; free from undesirable seed and coarse material.	2"-3" thick; 5 bales per 1000 sf or 2-3 tons per acre	Cost-effective protection when applied with adequate thickness. Hand-application generally requires greater thickness than blown straw. The thickness of straw may be reduced by half when used in conjunction with seeding. In windy areas straw must be held in place by crimping, using a tackifier, or covering with netting. Blown straw always has to be held in place with a tackifier as even light winds will blow it away. Straw, however, has several deficiencies that should be considered when selecting mulch materials. It often introduces and/or encourages the propagation of weed species and it has no significant long-term benefits. Straw should be used only if mulches with long-term benefits are unavailable locally. It should also not be used within the ordinary high-water elevation of surface waters (due to flotation).
Hydromulch	No growth inhibiting factors.	Approx. 25-30 lbs per 1000 sf or 1500 - 2000 lbs per acre	Shall be applied with hydromulcher. Shall not be used without seed and tackifier unless the application rate is at least doubled. Fibers longer than about ¾-1 inch clog hydromulch equipment. Fibers should be kept to less than ¾ inch.
Composted Mulch and Compost	No visible water or dust during handling. Must be purchased from supplier with Solid Waste Handling Permit (unless exempt).	2" thick min.; approx. 100 tons per acre (approx. 800 lbs per yard)	More effective control can be obtained by increasing thickness to 3". Excellent mulch for protecting final grades until landscaping because it can be directly seeded or tilled into soil as an amendment. Composted mulch has a coarser size gradation than compost. It is more stable and practical to use in wet areas and during rainy weather conditions.
Chipped Site Vegetation	Average size shall be several inches. Gradations from fines to 6 inches in length for texture, variation, and interlocking properties.	2" minimum thickness	This is a cost-effective way to dispose of debris from clearing and grubbing, and it eliminates the problems associated with burning. Generally, it should not be used on slopes above approx. 10% because of its tendency to be transported by runoff. It is not recommended within 200 feet of surface waters. If seeding is expected shortly after mulch, the decomposition of the chipped vegetation may tie up nutrients important to grass establishment.
Wood-based Mulch	No visible water or dust during handling. Must be purchased from a supplier with a Solid Waste Handling Permit or one exempt from solid waste regulations.	2" thick; approx. 100 tons per acre (approx. 800 lbs. per cubic yard)	This material is often called "hog or hogged fuel." It is usable as a material for Stabilized Construction Entrances (BMP C105) and as a mulch. The use of mulch ultimately improves the organic matter in the soil. Special caution is advised regarding the source and composition of wood-based mulches. Its preparation typically does not provide any weed seed control, so evidence of residual vegetation in its composition or known inclusion of weed plants or seeds should be monitored and prevented (or minimized).

BMP C123: Plastic Covering

Purpose

Plastic covering provides immediate, short-term erosion protection to slopes and disturbed areas.

Conditions of Use

- Plastic covering may be used on disturbed areas that require cover measures for less than 30 days, except as stated below.
- Plastic is particularly useful for protecting cut and fill slopes and stockpiles. Note: The relatively rapid breakdown of most polyethylene sheeting makes it unsuitable for long-term (greater than six months) applications.
- Clear plastic sheeting can be used over newly-seeded areas to create a greenhouse effect and encourage grass growth if the hydroseed was installed too late in the season to establish 75 percent grass cover, or if the wet season started earlier than normal. Clear plastic should not be used for this purpose during the summer months because the resulting high temperatures can kill the grass.
- Due to rapid runoff caused by plastic sheeting, this method shall not be used upslope of areas that might be adversely impacted by concentrated runoff. Such areas include steep and/or unstable slopes.
- While plastic is inexpensive to purchase, the added cost of installation, maintenance, removal, and disposal make this an expensive material, up to \$1.50-2.00 per square yard.
- Whenever plastic is used to protect slopes, water collection measures must be installed at the base of the slope. These measures include plastic-covered berms, channels, and pipes used to convey clean rainwater away from bare soil and disturbed areas. At no time is clean runoff from a plastic covered slope to be mixed with dirty runoff from a project.
- Other uses for plastic include:
 1. Temporary ditch liner;
 2. Pond liner in temporary sediment pond;
 3. Liner for bermed temporary fuel storage area if plastic is not reactive to the type of fuel being stored;
 4. Emergency slope protection during heavy rains; and,
 5. Temporary drainpipe (“elephant trunk”) used to direct water.

***Design and
Installation
Specifications***

- Plastic slope cover must be installed as follows:
 1. Run plastic up and down slope, not across slope;
 2. Plastic may be installed perpendicular to a slope if the slope length is less than 10 feet;
 3. Minimum of 8-inch overlap at seams;
 4. On long or wide slopes, or slopes subject to wind, all seams should be taped;
 5. Place plastic into a small (12-inch wide by 6-inch deep) slot trench at the top of the slope and backfill with soil to keep water from flowing underneath;
 6. Place sand filled burlap or geotextile bags every 3 to 6 feet along seams and pound a wooden stake through each to hold them in place;
 7. Inspect plastic for rips, tears, and open seams regularly and repair immediately. This prevents high velocity runoff from contacting bare soil which causes extreme erosion;
 8. Sandbags may be lowered into place tied to ropes. However, all sandbags must be staked in place.
- Plastic sheeting shall have a minimum thickness of 0.06 millimeters.
- If erosion at the toe of a slope is likely, a gravel berm, riprap, or other suitable protection shall be installed at the toe of the slope in order to reduce the velocity of runoff.

***Maintenance
Standards***

- Torn sheets must be replaced and open seams repaired.
- If the plastic begins to deteriorate due to ultraviolet radiation, it must be completely removed and replaced.
- When the plastic is no longer needed, it shall be completely removed.
- Dispose of old tires appropriately.

BMP C140: Dust Control

- Purpose*** Dust control prevents wind transport of dust from disturbed soil surfaces onto roadways, drainage ways, and surface waters.
- Conditions of Use***
- In areas (including roadways) subject to surface and air movement of dust where on-site and off-site impacts to roadways, drainage ways, or surface waters are likely.
- Design and Installation Specifications***
- Vegetate or mulch areas that will not receive vehicle traffic. In areas where planting, mulching, or paving is impractical, apply gravel or landscaping rock.
 - Limit dust generation by clearing only those areas where immediate activity will take place, leaving the remaining area(s) in the original condition, if stable. Maintain the original ground cover as long as practical.
 - Construct natural or artificial windbreaks or windscreens. These may be designed as enclosures for small dust sources.
 - Sprinkle the site with water until surface is wet. Repeat as needed. To prevent carryout of mud onto street, refer to Stabilized Construction Entrance (BMP C105).
 - Irrigation water can be used for dust control. Irrigation systems should be installed as a first step on sites where dust control is a concern.
 - Spray exposed soil areas with a dust palliative, following the manufacturer's instructions and cautions regarding handling and application. Used oil is prohibited from use as a dust suppressant. Local governments may approve other dust palliatives such as calcium chloride or PAM.
 - PAM (BMP C126) added to water at a rate of 0.5 lbs. per 1,000 gallons of water per acre and applied from a water truck is more effective than water alone. This is due to the increased infiltration of water into the soil and reduced evaporation. In addition, small soil particles are bonded together and are not as easily transported by wind. Adding PAM may actually reduce the quantity of water needed for dust control, especially in eastern Washington. Since the wholesale cost of PAM is about \$ 4.00 per pound, this is an extremely cost-effective dust control method.
- Techniques that can be used for unpaved roads and lots include:
- Lower speed limits. High vehicle speed increases the amount of dust stirred up from unpaved roads and lots.
 - Upgrade the road surface strength by improving particle size, shape, and mineral types that make up the surface and base materials.

- Add surface gravel to reduce the source of dust emission. Limit the amount of fine particles (those smaller than .075 mm) to 10 to 20 percent.
- Use geotextile fabrics to increase the strength of new roads or roads undergoing reconstruction.
- Encourage the use of alternate, paved routes, if available.
- Restrict use by tracked vehicles and heavy trucks to prevent damage to road surface and base.
- Apply chemical dust suppressants using the admix method, blending the product with the top few inches of surface material. Suppressants may also be applied as surface treatments.
- Pave unpaved permanent roads and other trafficked areas.
- Use vacuum street sweepers.
- Remove mud and other dirt promptly so it does not dry and then turn into dust.
- Limit dust-causing work on windy days.
- Contact your local Air Pollution Control Authority for guidance and training on other dust control measures. Compliance with the local Air Pollution Control Authority constitutes compliance with this BMP.

***Maintenance
Standards***

Respray area as necessary to keep dust to a minimum.

BMP C151: Concrete Handling

Purpose Concrete work can generate process water and slurry that contain fine particles and high pH, both of which can violate water quality standards in the receiving water. This BMP is intended to minimize and eliminate concrete process water and slurry from entering waters of the state.

Conditions of Use Any time concrete is used, these management practices shall be utilized. Concrete construction projects include, but are not limited to, the following:

- Curbs
- Sidewalks
- Roads
- Bridges
- Foundations
- Floors
- Runways
- Concrete truck chutes, pumps, and internals shall be washed out only into formed areas awaiting installation of concrete or asphalt.
- Unused concrete remaining in the truck and pump shall be returned to the originating batch plant for recycling.
- Hand tools including, but not limited to, screeds, shovels, rakes, floats, and trowels shall be washed off only into formed areas awaiting installation of concrete or asphalt.
- Equipment that cannot be easily moved, such as concrete pavers, shall only be washed in areas that do not directly drain to natural or constructed stormwater conveyances.
- Washdown from areas such as concrete aggregate driveways shall not drain directly to natural or constructed stormwater conveyances.
- When no formed areas are available, washwater and leftover product shall be contained in a lined container. Contained concrete shall be disposed of in a manner that does not violate groundwater or surface water quality standards.

Maintenance Standards Containers shall be checked for holes in the liner daily during concrete pours and repaired the same day.

BMP C152: Sawcutting and Surfacing Pollution Prevention

<i>Purpose</i>	Sawcutting and surfacing operations generate slurry and process water that contains fine particles and high pH (concrete cutting), both of which can violate the water quality standards in the receiving water. This BMP is intended to minimize and eliminate process water and slurry from entering waters of the State.
<i>Conditions of Use</i>	Anytime sawcutting or surfacing operations take place, these management practices shall be utilized. Sawcutting and surfacing operations include, but are not limited to, the following: <ul style="list-style-type: none">• Sawing• Coring• Grinding• Roughening• Hydro-demolition• Bridge and road surfacing
<i>Design and Installation Specifications</i>	<ul style="list-style-type: none">• Slurry and cuttings shall be vacuumed during cutting and surfacing operations.• Slurry and cuttings shall not remain on permanent concrete or asphalt pavement overnight.• Slurry and cuttings shall not drain to any natural or constructed drainage conveyance.• Collected slurry and cuttings shall be disposed of in a manner that does not violate groundwater or surface water quality standards.• Process water that is generated during hydro-demolition, surface roughening or similar operations shall not drain to any natural or constructed drainage conveyance and shall be disposed of in a manner that does not violate groundwater or surface water quality standards.• Cleaning waste material and demolition debris shall be handled and disposed of in a manner that does not cause contamination of water. If the area is swept with a pick-up sweeper, the material must be hauled out of the area to an appropriate disposal site.
<i>Maintenance Standards</i>	Continually monitor operations to determine whether slurry, cuttings, or process water could enter waters of the state. If inspections show that a violation of water quality standards could occur, stop operations and immediately implement preventive measures such as berms, barriers, secondary containment, and vacuum trucks.

BMP C160: Certified Erosion and Sediment Control Lead

Purpose

The project proponent designates at least one person as the responsible representative in charge of erosion and sediment control (ESC), and water quality protection. The designated person shall be the Certified Erosion and Sediment Control Lead (CESCL) who is responsible for ensuring compliance with all local, state, and federal erosion and sediment control and water quality requirements.

Conditions of Use

A CESCL shall be made available on projects one acre or larger that discharge stormwater to surface waters of the state

- The CESCL shall:
 - Have a current certificate proving attendance in an erosion and sediment control training course that meets the minimum ESC training and certification requirements established by Ecology (see details below).

Ecology will maintain a list of ESC training and certification providers at: www.ecy.wa.gov/programs/wq/stormwater.

OR

- Be a Certified Professional in Erosion and Sediment Control (CPESC); for additional information go to: www.cpesc.net

Specifications

- Certification shall remain valid for three years.
- The CESCL shall have authority to act on behalf of the contractor or developer and shall be available, on call, 24 hours per day throughout the period of construction.
- The Construction SWPPP shall include the name, telephone number, fax number, and address of the designated CESCL.
- A CESCL may provide inspection and compliance services for multiple construction projects in the same geographic region.

Duties and responsibilities of the CESCL shall include, but are not limited to the following:

- Maintaining permit file on site at all times which includes the SWPPP and any associated permits and plans.
- Directing BMP installation, inspection, maintenance, modification, and removal.
- Updating all project drawings and the Construction SWPPP with changes made.

- Keeping daily logs, and inspection reports. Inspection reports should include:
 - Inspection date/time.
 - Weather information; general conditions during inspection and approximate amount of precipitation since the last inspection.
 - A summary or list of all BMPs implemented, including observations of all erosion/sediment control structures or practices. The following shall be noted:
 - 1) Locations of BMPs inspected,
 - 2) Locations of BMPs that need maintenance,
 - 3) Locations of BMPs that failed to operate as designed or intended, and
 - 4) Locations of where additional or different BMPs are required.
 - Visual monitoring results, including a description of discharged stormwater. The presence of suspended sediment, turbid water, discoloration, and oil sheen shall be noted, as applicable.
 - Any water quality monitoring performed during inspection.
 - General comments and notes, including a brief description of any BMP repairs, maintenance or installations made as a result of the inspection.
- Facilitate, participate in, and take corrective actions resulting from inspections performed by outside agencies or the owner.

Minimum Requirements for ESC Training and Certification Courses

General Requirements

1. The course shall teach the construction stormwater pollution prevention guidance provided in the most recent version of:
 - a. The Washington State Dept. of Ecology Stormwater Management Manual for Western Washington,
 - b. Other equivalent stormwater management manuals approved by Ecology.
2. Upon completion of course, each attendee shall receive documentation of certification, including, at a minimum, a wallet-sized card that certifies completion of the course. Certification shall remain valid for three years. Recertification may be obtained by completing the 8-hour refresher course or by taking the initial 16-hour training course again.
3. The initial certification course shall be a minimum of 16 hours (with a reasonable time allowance for lunch, breaks, and travel to and from field) and include a field element and test.
 - a. The field element must familiarize students with the proper installation, maintenance and inspection of common erosion and sediment control BMPs including, but not limited to, blankets, check dams, silt fence, straw mulch, plastic, and seeding.
 - b. The test shall be open book and a passing score is not required for certification. Upon completion of the test, the correct answers shall be provided and discussed.
4. The refresher course shall be a minimum of 8 hours and include a test.
 - a. The refresher course shall include:
 - i. Applicable updates to the Stormwater Management Manual that is used to teach the course, including new or updated BMPs; and
 - ii. Applicable changes to the NPDES General Permit for Construction Activities.
 - b. The refresher course test shall be open book and a passing score is not required for certification. Upon completion of the test, the correct answers shall be provided and discussed.
 - c. The refresher course may be taught using an alternative format (e.g. internet, CD ROM, etc.) if the module is approved by Ecology.

Required Course Elements

1. Erosion and Sedimentation Impacts
 - a. Examples/Case studies

2. Erosion and Sedimentation Processes
 - a. Definitions
 - b. Types of erosion
 - c. Sedimentation
 - i. Basic settling concepts
 - ii. Problems with clays/turbidity
3. Factors Influencing Erosion Potential
 - a. Soil
 - b. Vegetation
 - c. Topography
 - d. Climate
4. Regulatory Requirements
 - a. NPDES - Construction Stormwater General Permit
 - b. Local requirements and permits
 - c. Other regulatory requirements
5. Stormwater Pollution Prevention Plan (SWPPP)
 - a. SWPPP is a living document – should be revised as necessary
 - b. 12 Elements of a SWPPP; discuss suggested BMPs (with examples)
 1. Mark Clearing Limits
 2. Establish Construction Access
 3. Control Flow Rates
 4. Install Sediment Controls
 5. Stabilize Soils
 6. Protect Slopes
 7. Protect Drain Inlets
 8. Stabilize Channels and Outlets
 9. Control Pollutants
 10. Control De-watering
 11. Maintain BMPs
 12. Manage the Project
6. Monitoring/Reporting/Recordkeeping
 - a. Site inspections/visual monitoring
 - i. Disturbed areas
 - ii. BMPs
 - iii. Stormwater discharge points
 - b. Water quality sampling/analysis
 - i. Turbidity
 - ii. pH
 - c. Monitoring frequency
 - i. Set by NPDES permit
 - ii. Inactive sites - reduced frequency

- d. Adaptive Management
 - i. When monitoring indicates problem, take appropriate action (e.g. install/maintain BMPs)
 - ii. Document the corrective action(s) in SWPPP
- e. Reporting
 - i. Inspection reports/checklists
 - ii. Discharge Monitoring Reports (DMR)
 - iii. Non-compliance notification

Instructor Qualifications

1. Instructors must be qualified to effectively teach the required course elements.
2. At a minimum, instructors must have:
 - a. Current certification as a Certified Professional in Erosion and Sediment Control (CPESC), or
 - b. Completed a training program for teaching the required course elements, or
 - c. The academic credentials and instructional experience necessary for teaching the required course elements.
3. Instructors must demonstrate competent instructional skills and knowledge of the applicable subject matter.

BMP C220: Storm Drain Inlet Protection

Purpose To prevent coarse sediment from entering drainage systems prior to permanent stabilization of the disturbed area.

Conditions of Use Where storm drain inlets are to be made operational before permanent stabilization of the disturbed drainage area. Protection should be provided for all storm drain inlets downslope and within 500 feet of a disturbed or construction area, unless the runoff that enters the catch basin will be conveyed to a sediment pond or trap. Inlet protection may be used anywhere to protect the drainage system. It is likely that the drainage system will still require cleaning.

Table 4.9 lists several options for inlet protection. All of the methods for storm drain inlet protection are prone to plugging and require a high frequency of maintenance. Drainage areas should be limited to 1 acre or less. Emergency overflows may be required where stormwater ponding would cause a hazard. If an emergency overflow is provided, additional end-of-pipe treatment may be required.

Table 4.9 Storm Drain Inlet Protection			
Type of Inlet Protection	Emergency Overflow	Applicable for Paved/ Earthen Surfaces	Conditions of Use
Drop Inlet Protection			
Excavated drop inlet protection	Yes, temporary flooding will occur	Earthen	Applicable for heavy flows. Easy to maintain. Large area Requirement: 30' X 30'/acre
Block and gravel drop inlet protection	Yes	Paved or Earthen	Applicable for heavy concentrated flows. Will not pond.
Gravel and wire drop inlet protection	No		Applicable for heavy concentrated flows. Will pond. Can withstand traffic.
Catch basin filters	Yes	Paved or Earthen	Frequent maintenance required.
Curb Inlet Protection			
Curb inlet protection with a wooden weir	Small capacity overflow	Paved	Used for sturdy, more compact installation.
Block and gravel curb inlet protection	Yes	Paved	Sturdy, but limited filtration.
Culvert Inlet Protection			
Culvert inlet sediment trap			18 month expected life.

***Design and
Installation
Specifications***

Excavated Drop Inlet Protection - An excavated impoundment around the storm drain. Sediment settles out of the stormwater prior to entering the storm drain.

- Depth 1-2 ft as measured from the crest of the inlet structure.
- Side Slopes of excavation no steeper than 2:1.
- Minimum volume of excavation 35 cubic yards.
- Shape basin to fit site with longest dimension oriented toward the longest inflow area.
- Install provisions for draining to prevent standing water problems.
- Clear the area of all debris.
- Grade the approach to the inlet uniformly.
- Drill weep holes into the side of the inlet.
- Protect weep holes with screen wire and washed aggregate.
- Seal weep holes when removing structure and stabilizing area.
- It may be necessary to build a temporary dike to the down slope side of the structure to prevent bypass flow.

Block and Gravel Filter - A barrier formed around the storm drain inlet with standard concrete blocks and gravel. See Figure 4.14.

- Height 1 to 2 feet above inlet.
- Recess the first row 2 inches into the ground for stability.
- Support subsequent courses by placing a 2x4 through the block opening.
- Do not use mortar.
- Lay some blocks in the bottom row on their side for dewatering the pool.
- Place hardware cloth or comparable wire mesh with ½-inch openings over all block openings.
- Place gravel just below the top of blocks on slopes of 2:1 or flatter.
- An alternative design is a gravel donut.
- Inlet slope of 3:1.
- Outlet slope of 2:1.
- 1-foot wide level stone area between the structure and the inlet.
- Inlet slope stones 3 inches in diameter or larger.
- Outlet slope use gravel ½- to ¾-inch at a minimum thickness of 1-foot.

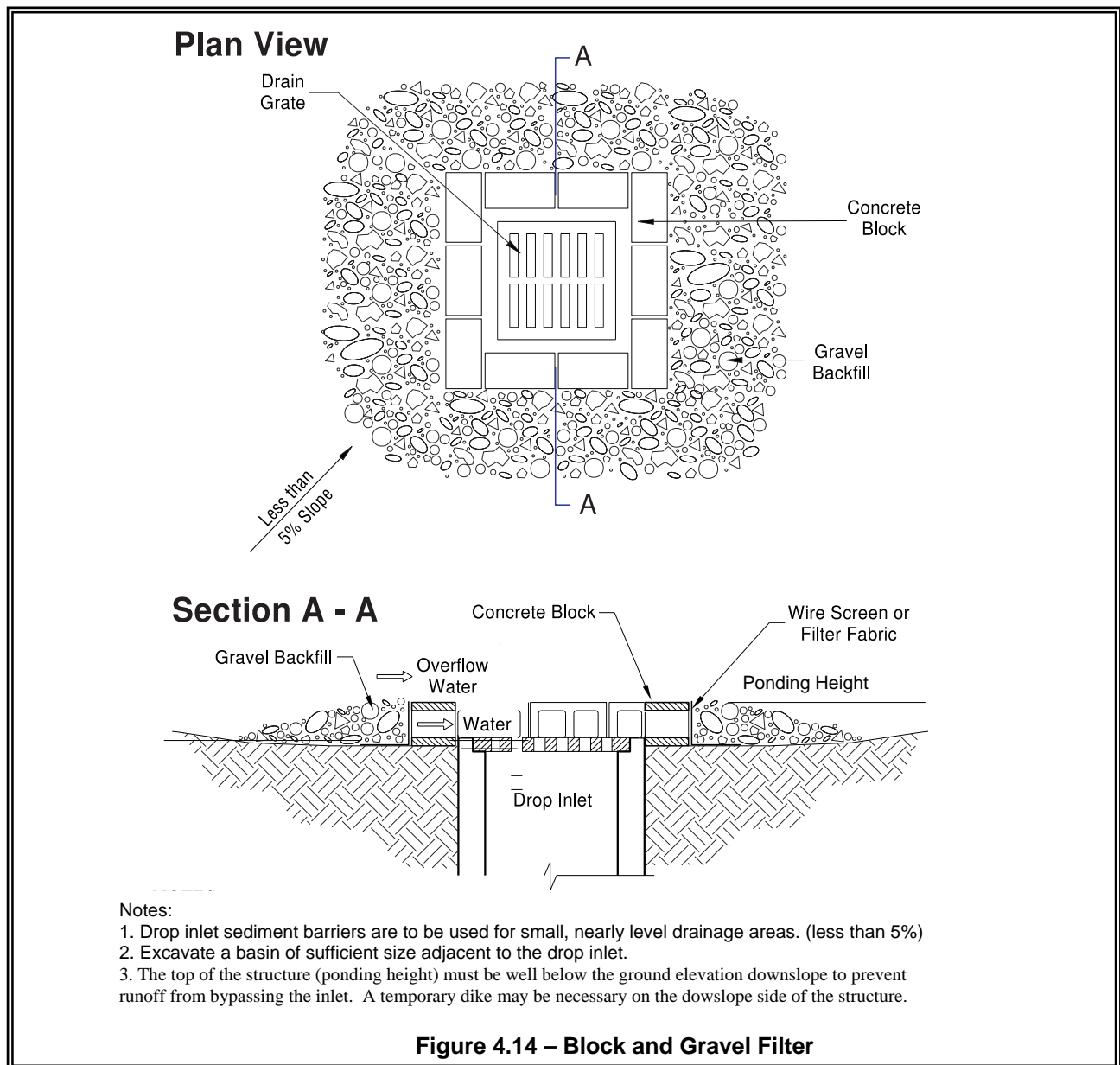

Figure 4.14 – Block and Gravel Filter

Gravel and Wire Mesh Filter - A gravel barrier placed over the top of the inlet. This structure does not provide an overflow.

- Hardware cloth or comparable wire mesh with ½-inch openings.
- Coarse aggregate.
- Height 1-foot or more, 18 inches wider than inlet on all sides.
- Place wire mesh over the drop inlet so that the wire extends a minimum of 1-foot beyond each side of the inlet structure.
- If more than one strip of mesh is necessary, overlap the strips.
- Place coarse aggregate over the wire mesh.
- The depth of the gravel should be at least 12 inches over the entire inlet opening and extend at least 18 inches on all sides.

Catchbasin Filters - Inserts should be designed by the manufacturer for use at construction sites. The limited sediment storage capacity increases the amount of inspection and maintenance required, which may be daily for heavy sediment loads. The maintenance requirements can be reduced by combining a catchbasin filter with another type of inlet protection. This type of inlet protection provides flow bypass without overflow and therefore may be a better method for inlets located along active rights-of-way.

- 5 cubic feet of storage.
- Dewatering provisions.
- High-flow bypass that will not clog under normal use at a construction site.
- The catchbasin filter is inserted in the catchbasin just below the grating.

Curb Inlet Protection with Wooden Weir – Barrier formed around a curb inlet with a wooden frame and gravel.

- Wire mesh with ½-inch openings.
- Extra strength filter cloth.
- Construct a frame.
- Attach the wire and filter fabric to the frame.
- Pile coarse washed aggregate against wire/fabric.
- Place weight on frame anchors.

Block and Gravel Curb Inlet Protection – Barrier formed around an inlet with concrete blocks and gravel. See Figure 4.14.

- Wire mesh with ½-inch openings.
- Place two concrete blocks on their sides abutting the curb at either side of the inlet opening. These are spacer blocks.
- Place a 2x4 stud through the outer holes of each spacer block to align the front blocks.
- Place blocks on their sides across the front of the inlet and abutting the spacer blocks.
- Place wire mesh over the outside vertical face.
- Pile coarse aggregate against the wire to the top of the barrier.

Curb and Gutter Sediment Barrier – Sandbag or rock berm (riprap and aggregate) 3 feet high and 3 feet wide in a horseshoe shape. See Figure 4.16.

- Construct a horseshoe shaped berm, faced with coarse aggregate if using riprap, 3 feet high and 3 feet wide, at least 2 feet from the inlet.
- Construct a horseshoe shaped sedimentation trap on the outside of the berm sized to sediment trap standards for protecting a culvert inlet.

***Maintenance
Standards***

- Catch basin filters should be inspected frequently, especially after storm events. If the insert becomes clogged, it should be cleaned or replaced.
- For systems using stone filters: If the stone filter becomes clogged with sediment, the stones must be pulled away from the inlet and cleaned or replaced. Since cleaning of gravel at a construction site may be difficult, an alternative approach would be to use the clogged stone as fill and put fresh stone around the inlet.
- Do not wash sediment into storm drains while cleaning. Spread all excavated material evenly over the surrounding land area or stockpile and stabilize as appropriate.

Plan View

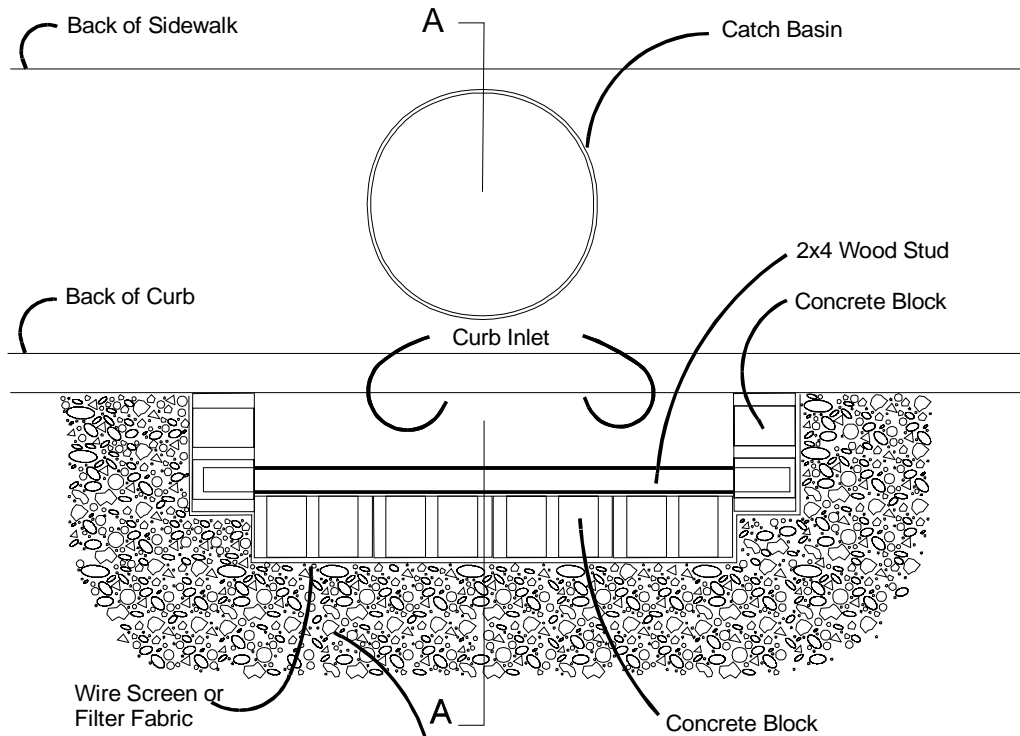

Section A - A

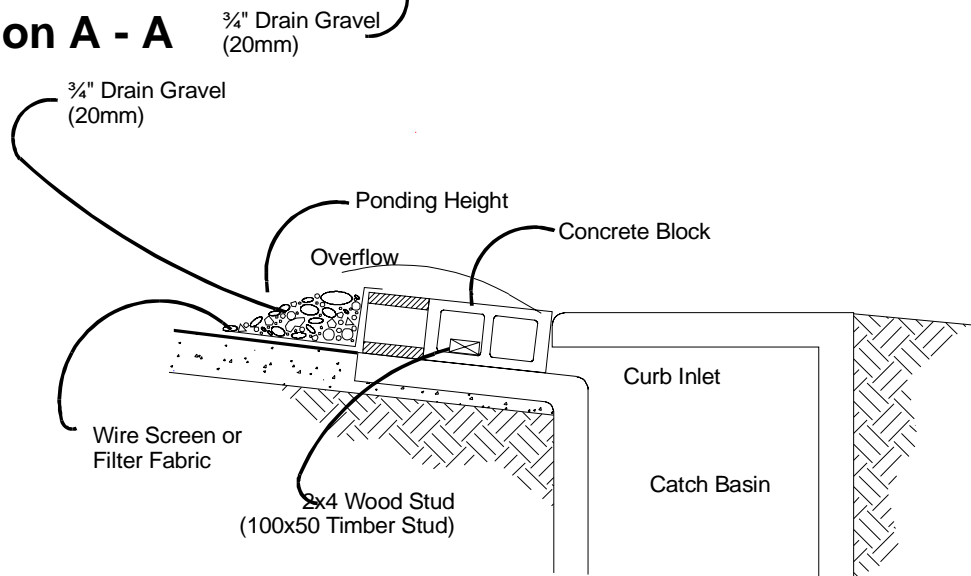

NOTES:

1. Use block and gravel type sediment barrier when curb inlet is located in gently sloping street segment, where water can pond and allow sediment to separate from runoff.
2. Barrier shall allow for overflow from severe storm event.
3. Inspect barriers and remove sediment after each storm event. Sediment and gravel must be removed from the traveled way immediately.

Figure 4.15 – Block and Gravel Curb Inlet Protection

Plan View

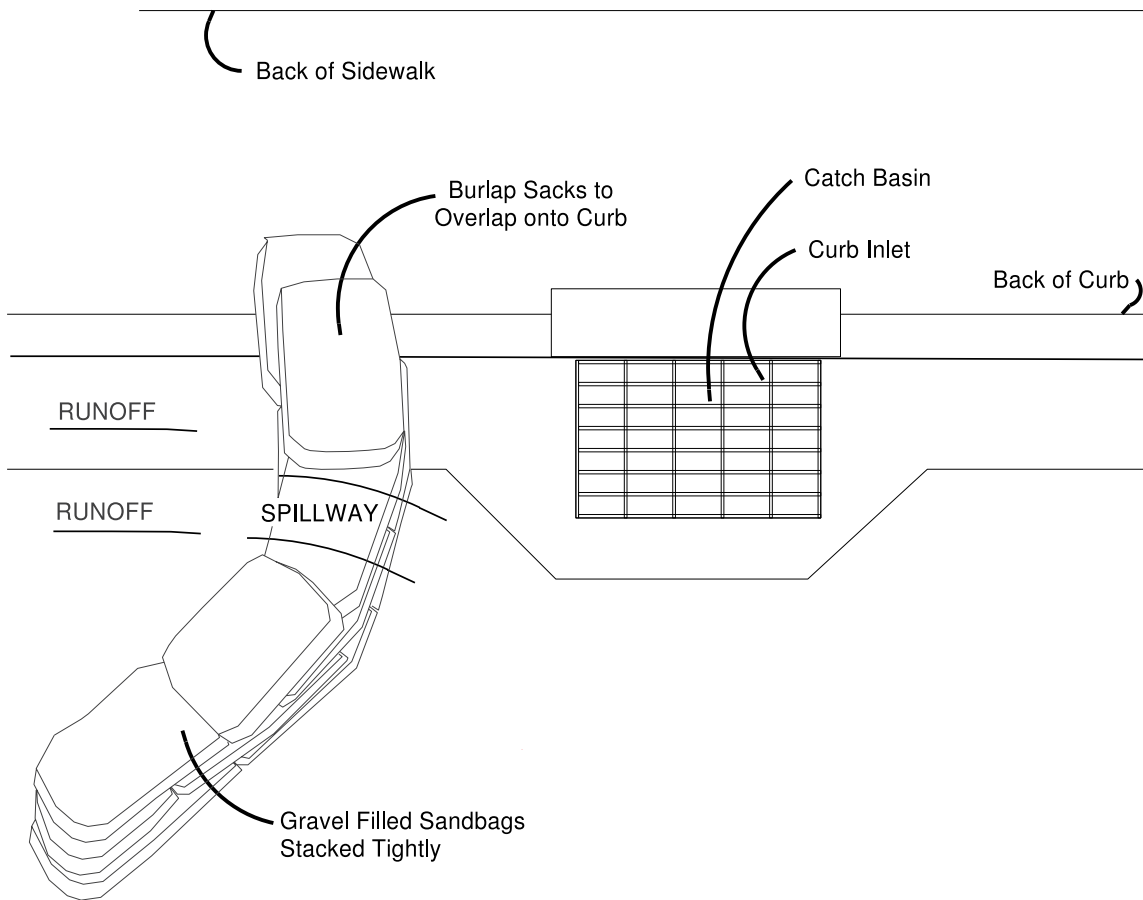

NOTES:

1. Place curb type sediment barriers on gently sloping street segments, where water can pond and allow sediment to separate from runoff.
2. Sandbags of either burlap or woven 'geotextile' fabric, are filled with gravel, layered and packed tightly.
3. Leave a one sandbag gap in the top row to provide a spillway for overflow.
4. Inspect barriers and remove sediment after each storm event. Sediment and gravel must be removed from the traveled way immediately.

Figure 4.16 – Curb and Gutter Barrier

BMP C233: Silt Fence

Purpose

Use of a silt fence reduces the transport of coarse sediment from a construction site by providing a temporary physical barrier to sediment and reducing the runoff velocities of overland flow. See Figure 4.19 for details on silt fence construction.

Conditions of Use

Silt fence may be used downslope of all disturbed areas.

- Silt fence is not intended to treat concentrated flows, nor is it intended to treat substantial amounts of overland flow. Any concentrated flows must be conveyed through the drainage system to a sediment pond. The only circumstance in which overland flow can be treated solely by a silt fence, rather than by a sediment pond, is when the area draining to the fence is one acre or less and flow rates are less than 0.5 cfs.
- Silt fences should not be constructed in streams or used in V-shaped ditches. They are not an adequate method of silt control for anything deeper than sheet or overland flow.

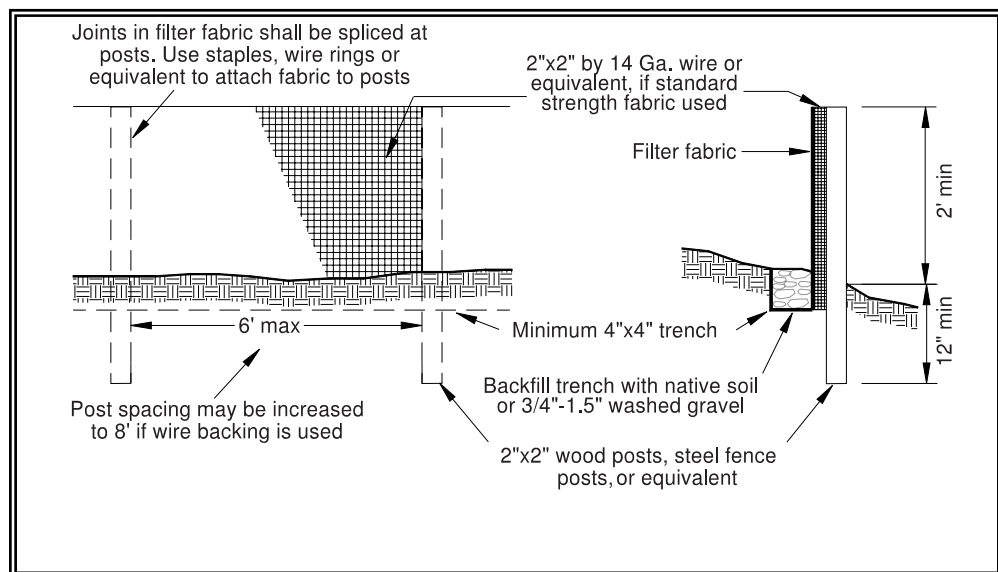

Figure 4.19 – Silt Fence

Design and Installation Specifications

- Drainage area of 1 acre or less or in combination with sediment basin in a larger site.
- Maximum slope steepness (normal (perpendicular) to fence line) 1:1.
- Maximum sheet or overland flow path length to the fence of 100 feet.
- No flows greater than 0.5 cfs.
- The geotextile used shall meet the following standards. All geotextile properties listed below are minimum average roll values (i.e., the test result for any sampled roll in a lot shall meet or exceed the values shown in Table 4.10):

Polymeric Mesh AOS (ASTM D4751)	0.60 mm maximum for slit film wovens (#30 sieve). 0.30 mm maximum for all other geotextile types (#50 sieve). 0.15 mm minimum for all fabric types (#100 sieve).
Water Permittivity (ASTM D4491)	0.02 sec ⁻¹ minimum
Grab Tensile Strength (ASTM D4632)	180 lbs. Minimum for extra strength fabric. 100 lbs minimum for standard strength fabric.
Grab Tensile Strength (ASTM D4632)	30% maximum
Ultraviolet Resistance (ASTM D4355)	70% minimum

- Standard strength fabrics shall be supported with wire mesh, chicken wire, 2-inch x 2-inch wire, safety fence, or jute mesh to increase the strength of the fabric. Silt fence materials are available that have synthetic mesh backing attached.
- Filter fabric material shall contain ultraviolet ray inhibitors and stabilizers to provide a minimum of six months of expected usable construction life at a temperature range of 0°F. to 120°F.
- 100 percent biodegradable silt fence is available that is strong, long lasting, and can be left in place after the project is completed, if permitted by local regulations.
- Standard Notes for construction plans and specifications follow. Refer to Figure 4.19 for standard silt fence details.

The contractor shall install and maintain temporary silt fences at the locations shown in the Plans. The silt fences shall be constructed in the areas of clearing, grading, or drainage prior to starting those activities. A silt fence shall not be considered temporary if the silt fence must function beyond the life of the contract. The silt fence shall prevent soil carried by runoff water from going beneath, through, or over the top of the silt fence, but shall allow the water to pass through the fence.

The minimum height of the top of silt fence shall be 2 feet and the maximum height shall be 2½ feet above the original ground surface.

The geotextile shall be sewn together at the point of manufacture, or at an approved location as determined by the Engineer, to form geotextile lengths as required. All sewn seams shall be located at a support post. Alternatively, two sections of silt fence can be overlapped, provided the Contractor can demonstrate, to the satisfaction of the Engineer, that the overlap is long enough and that the adjacent fence sections are close enough together to prevent silt laden water from escaping through the fence at the overlap.

The geotextile shall be attached on the up-slope side of the posts and support system with staples, wire, or in accordance with the manufacturer's recommendations. The geotextile shall be attached to the posts in a manner that reduces the potential for geotextile tearing at the staples, wire, or other connection device. Silt fence back-up support for the geotextile in the form of a wire or plastic mesh is dependent on the properties of the geotextile selected for use. If wire or plastic back-up mesh is used, the mesh shall be fastened securely to the up-slope of the posts with the geotextile being up-slope of the mesh back-up support.

The geotextile at the bottom of the fence shall be buried in a trench to a minimum depth of 4 inches below the ground surface. The trench shall be backfilled and the soil tamped in place over the buried portion of the geotextile, such that no flow can pass beneath the fence and scouring can not occur. When wire or polymeric back-up support mesh is used, the wire or polymeric mesh shall extend into the trench a minimum of 3 inches.

The fence posts shall be placed or driven a minimum of 18 inches. A minimum depth of 12 inches is allowed if topsoil or other soft subgrade soil is not present and a minimum depth of 18 inches cannot be reached. Fence post depths shall be increased by 6 inches if the fence is located on slopes of 3:1 or steeper and the slope is perpendicular to the fence. If required post depths cannot be obtained, the posts shall be adequately secured by bracing or guying to prevent overturning of the fence due to sediment loading.

Silt fences shall be located on contour as much as possible, except at the ends of the fence, where the fence shall be turned uphill such that the silt fence captures the runoff water and prevents water from flowing around the end of the fence.

If the fence must cross contours, with the exception of the ends of the fence, gravel check dams placed perpendicular to the back of the fence shall be used to minimize concentrated flow and erosion along the back of the fence. The gravel check dams shall be approximately 1-foot deep at the back of the fence. It shall be continued perpendicular to the fence at the same elevation until the top of the check dam intercepts the ground surface behind the fence. The gravel check dams shall consist of crushed surfacing base course, gravel backfill for walls, or shoulder ballast. The gravel check dams shall be located every 10 feet along the fence where the fence must cross contours. The slope of the fence line where contours must be crossed shall not be steeper than 3:1.

Wood, steel or equivalent posts shall be used. Wood posts shall have minimum dimensions of 2 inches by 2 inches by 3 feet minimum length, and shall be free of defects such as knots, splits, or gouges.

Steel posts shall consist of either size No. 6 rebar or larger, ASTM A 120 steel pipe with a minimum diameter of 1-inch, U, T, L, or C shape steel posts with a minimum weight of 1.35 lbs./ft. or other steel posts having equivalent strength and bending resistance to the post sizes listed. The spacing of the support posts shall be a maximum of 6 feet.

Fence back-up support, if used, shall consist of steel wire with a maximum mesh spacing of 2 inches, or a prefabricated polymeric mesh. The strength of the wire or polymeric mesh shall be equivalent to or greater than 180 lbs. grab tensile strength. The polymeric mesh must be as resistant to ultraviolet radiation as the geotextile it supports.

- Silt fence installation using the slicing method specification details follow. Refer to Figure 4.20 for slicing method details.

The base of both end posts must be at least 2 to 4 inches above the top of the silt fence fabric on the middle posts for ditch checks to drain properly. Use a hand level or string level, if necessary, to mark base points before installation.

Install posts 3 to 4 feet apart in critical retention areas and 6 to 7 feet apart in standard applications.

Install posts 24 inches deep on the downstream side of the silt fence, and as close as possible to the fabric, enabling posts to support the fabric from upstream water pressure.

Install posts with the nipples facing away from the silt fence fabric.

Attach the fabric to each post with three ties, all spaced within the top 8 inches of the fabric. Attach each tie diagonally 45 degrees through the fabric, with each puncture at least 1 inch vertically apart. In addition, each tie should be positioned to hang on a post nipple when tightening to prevent sagging.

Wrap approximately 6 inches of fabric around the end posts and secure with 3 ties.

No more than 24 inches of a 36-inch fabric is allowed above ground level.

The rope lock system must be used in all ditch check applications.

The installation should be checked and corrected for any deviation before compaction. Use a flat-bladed shovel to tuck fabric deeper into the ground if necessary.

Compaction is vitally important for effective results. Compact the soil immediately next to the silt fence fabric with the front wheel of the tractor, skid steer, or roller exerting at least 60 pounds per square inch. Compact the upstream side first and then each side twice for a total of four trips.

Maintenance Standards

- Any damage shall be repaired immediately.
- If concentrated flows are evident uphill of the fence, they must be intercepted and conveyed to a sediment pond.
- It is important to check the uphill side of the fence for signs of the fence clogging and acting as a barrier to flow and then causing channelization of flows parallel to the fence. If this occurs, replace the fence or remove the trapped sediment.
- Sediment deposits shall either be removed when the deposit reaches approximately one-third the height of the silt fence, or a second silt fence shall be installed.
- If the filter fabric (geotextile) has deteriorated due to ultraviolet breakdown, it shall be replaced.

