

2504 E Main Avenue
Puyallup, WA

Traffic Impact Analysis

April 18, 2022

Prepared for:

IDI Logistics
840 Apollo Street, Suite 343
El Segundo, CA 90245

Prepared by:



Transportation Engineering NorthWest

11400 SE 8th Street, Suite 200
Bellevue, WA 98004
(425) 889-6747

Table of Contents

FINDINGS & CONCLUSIONS	1
INTRODUCTION	3
Project Description	3
Project Approach	3
Primary Data and Information Sources	3
EXISTING CONDITIONS	6
Roadway Network	6
Study Intersections	7
Existing Traffic Volumes	7
Public Transportation Services	7
Non-motorized Transportation Facilities	7
Level of Service	9
True Demand	10
WITH PROJECT CONDITIONS	12
Project Trip Generation	12
Project Trip Distribution and Assignment	12
Future Traffic Volumes	12
Level of Service at Study Intersections	15
Site Access Operations	16
<i>Level of Service as a Two-Way Stop-Controlled Intersection</i>	16
<i>Signal Warrant Analysis</i>	16
<i>Right Turn Lane Evaluation</i>	17
MITIGATION	18
Off-Site SEPA Improvements	18
Transportation Impact Fees	18

Appendices

- Appendix A – Existing Peak Hour Turning Movement Count Sheets
- Appendix B – Level of Service (LOS) Calculations at Study Intersections
- Appendix C – True Demand Calculations
- Appendix D – Trip Generation Calculations
- Appendix E – Signal Warrant Analysis
- Appendix F – Right-Turn Lane Evaluation

List of Figures and Tables

Figure 1	Project Site Vicinity	4
Figure 2	Preliminary Site Plan	5
Figure 3	Year 2022 Existing Weekday PM Peak Hour Traffic Volumes	8
Figure 4	Weekday Peak Hour Project Trip Distribution and Assignment	13
Figure 5	Year 2022 With Project Weekday PM Peak Hour Traffic Volumes.....	14
Table 1	Existing Study Area Roadway Network	6
Table 2	LOS Criteria for Signalized and Stop-Controlled Intersections ¹	9
Table 3	2022 Existing PM Peak Hour Level of Service Summary	10
Table 4	Future 2022 PM Peak Hour True Demand Summary.....	11
Table 5	Project Trip Generation Summary.....	12
Table 6	2022 With Project PM Peak Hour Level of Service Summary	15
Table 7	E Main Ave/Site Access Signal Warrant Analysis	17

FINDINGS & CONCLUSIONS

This traffic impact analysis (TIA) has been prepared for the proposed *2504 E Main Ave* manufacturing development project located in the City of Puyallup, WA. The purpose of this TIA is to document the traffic impacts associated with the change in use from the previously entitled warehouse use to the proposed manufacturing use.

Project Proposal. The proposed *2504 E Main Ave* project includes the development of 210,376 square feet (SF) of new building area designated for a manufacturing tenant. The site was previously entitled for 199,184 SF of warehouse use. Primary vehicular access to the site is proposed via a single full access driveway on E Main Avenue. The project is expected to be completed and occupied in 2022.

Project Trip Generation. The *2504 E Main Ave* project is estimated to generate 999 new weekday daily trips, with 143 new trips occurring during the weekday AM peak hour (109 in, 34 out) and 156 new trips occurring during the weekday PM peak hour (48 in, 108 out).

Intersection LOS Results. Intersection LOS were evaluated at 10 study intersections in the vicinity area for weekday PM peak hour conditions with the project. The LOS analysis results indicate that all signalized study intersections are anticipated to meet the established LOS standards (LOS D or better) under 2022 weekday PM peak hour conditions with the project.

The results of the LOS analysis also indicate that all controlled movements at the two-way stop controlled site access study intersection are anticipated to meet the established LOS standard (LOS D or better) under 2022 With Project weekday PM peak hour.

Intersection True Demand. Weekday PM peak hour true demand and the vehicular queueing volume associated with each turning movement were evaluated at four (4) study intersections.

Site Access Analysis (Linden Lane Apartment Dwy/E Main Ave/Site Access)

LOS Analysis – As a two-way stop-controlled intersection in 2022 with the proposed *2504 E Main Ave* project, all controlled movements at the Linden Lane Apartment Dwy/E Main Ave/Site Access intersection are anticipated to operate at LOS D or better.

Right-Turn Lane Analysis – Evaluation of the need for an eastbound right-turn lane was conducted at the proposed site access intersection on E Main Ave. Based on WSDOT Exhibit 1310-11 (right-turn lane guidelines) and forecast 2022 With Project traffic volumes, an eastbound right-turn lane would not be warranted.

Signal Warrant Analysis – Based on forecast 2022 traffic volumes with the *2504 E Main Ave* project, none of the signal warrants evaluated would be met at the Linden Lane Apartment Dwy/E Main Ave/Site Access intersection.

Mitigation

Off-Site SEPA Improvements – Based on the results of the analysis shown in this report, no project-specific off-site transportation mitigation is proposed for concurrency or SEPA purposes.

Transportation Impact Fees – To mitigate long-term transportation impacts, the City administers a Transportation Impact Fee (TIF) to new developments to improve the transportation system to accommodate the higher travel demand added by new development. The net impact fee is calculated based on the project's proposed land use less an impact fee credit for the existing land use. The City's current adopted transportation impact fee is \$4,500 per PM peak hour trip. The preliminary estimated transportation impact fee for the proposed project totals **\$700,650** (\$4,500 X 155.7 net new PM peak hour trips). However, \$166,500 in transportation impact fees were paid for the previously approved warehouse use and should be applied as credit for the proposed change in use to manufacturing. Therefore, the net new impact fees owed with the proposed *2504 E Main Ave* project is **\$534,150** (\$700,650 - \$166,500). Fees are subject to change, and the final impact fee calculation will be based on the rates and project size in effect at the time of building permit issuance.

INTRODUCTION

This traffic impact analysis (TIA) has been prepared for the *2504 E Main Ave* manufacturing project located in the City of Puyallup, WA (see **Figure 1**). The purpose of this TIA is to document the traffic impacts associated with the change in use from the previously entitled warehouse use to the proposed manufacturing use.

Project Description

The proposed *2504 E Main Ave* project includes the development of 210,376 square feet (SF) of new building area designated for a manufacturing tenant. The site was previously entitled for 199,184 SF of warehouse use. Primary vehicular access to the site is proposed via a single full access driveway on E Main Avenue.

The project is expected to be completed and occupied in 2022. A preliminary site plan is provided in **Figure 2**.

Project Approach

Based on traffic scoping discussions with City of Puyallup staff, the following tasks were undertaken to evaluate and disclose the traffic impacts associated with the *2504 E Main Ave* project:

1. Assessed existing conditions through field reconnaissance and reviewed existing planning documents;
2. Described and assessed existing transportation conditions in the area;
3. Documented planned transportation improvements in the site vicinity;
4. Estimated trip generation and documented trip distribution and assignment of project traffic;
5. Documented traffic forecasts and assumptions for future year 2022 conditions with the proposed project;
6. Conducted PM peak hour level of service analyses at 10 study intersections for 2022 existing and 2022 With Project conditions;
7. Evaluated PM peak hour true demand at select intersections for 2022 With Project conditions;
8. Evaluated signal warrants at the intersection of E Main Ave/Site Access for 2022 With Project conditions;
9. Identified improvements to mitigate impacts of the project onto the adjacent street system.

Primary Data and Information Sources

- PM Peak Hour traffic counts, 2022.
- Weekday Daily Traffic Counts at E Main Ave/Site Access, 2022.
- Institute of Transportation Engineers (ITE), *Trip Generation Manual*, 11th Edition, 2021.
- *Highway Capacity Manual (HCM) 6th Edition*, TRB.
- Pierce Transit website, April 2022.

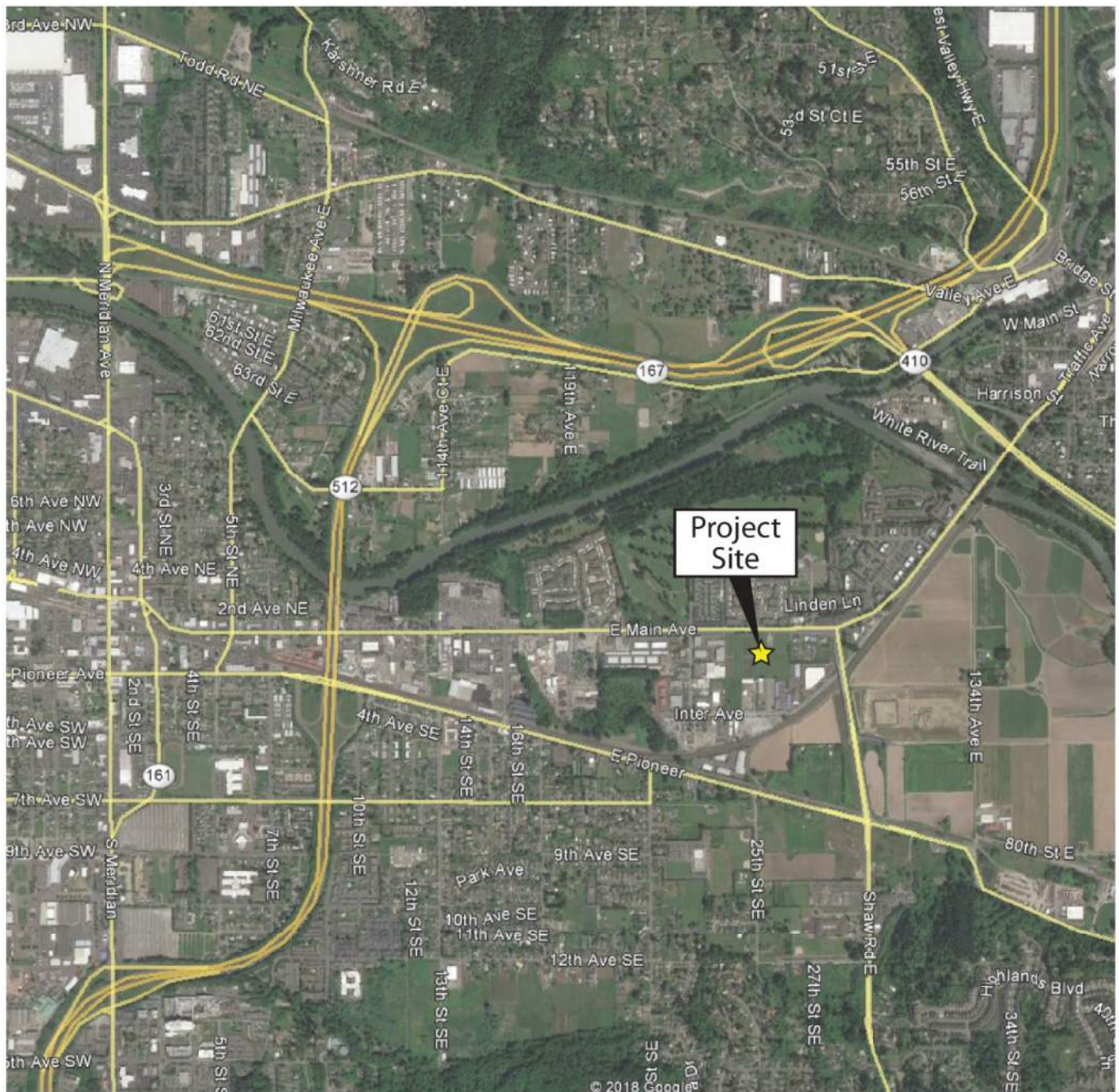

Figure 1: Project Site Vicinity



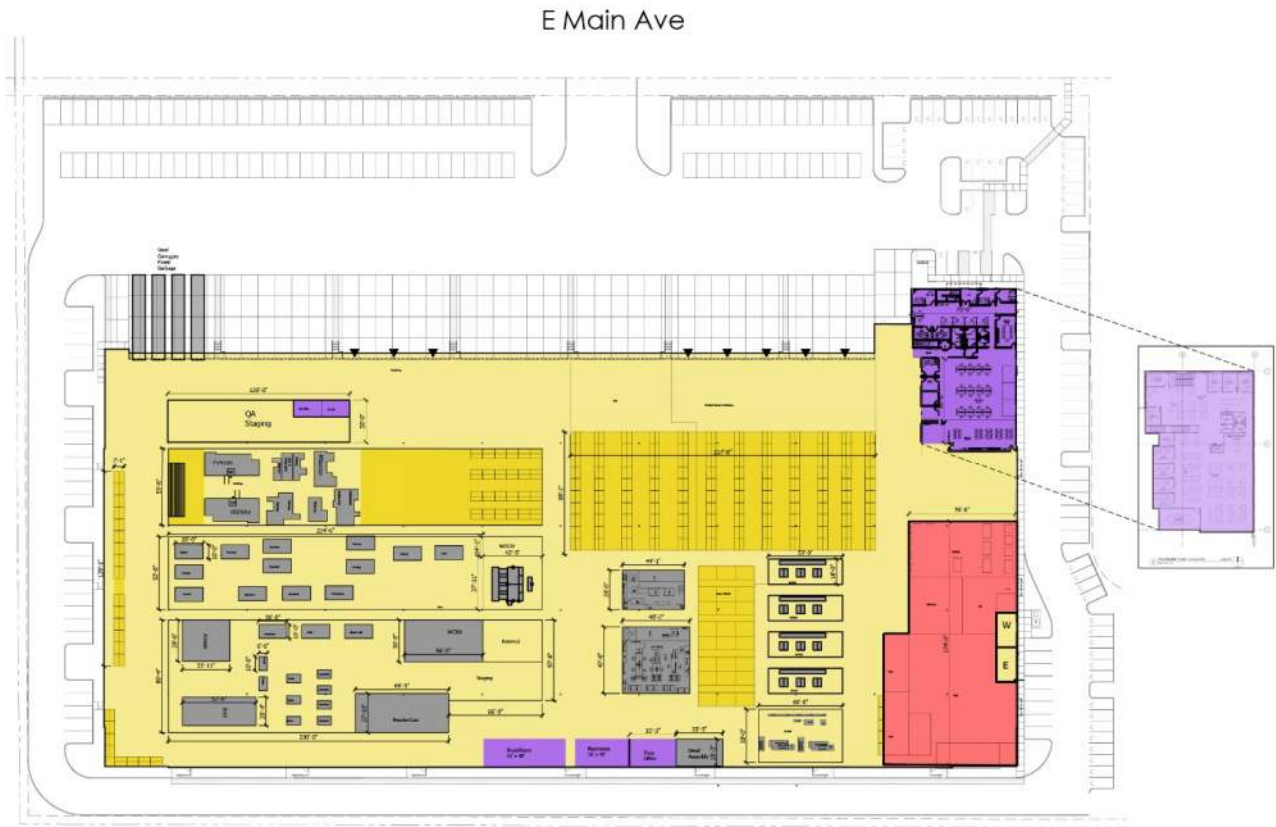

Figure 2: Preliminary Site Plan



EXISTING CONDITIONS

Roadway Network

Table 1 describes the existing characteristics of the streets that would be used as primary routes to and from the site. Roadway characteristics are described in terms of orientation, arterial classification, posted speed limits, number of lanes, paved shoulders, and pedestrian facilities. The relationship of these roadways to the project site is shown in **Figure 1**.

Table 1
Existing Study Area Roadway Network

Roadway	Orientation	Arterial Classification	# of Lanes	Posted Speed Limit (mph)	Parking	Sidewalks	Bicycle Facilities
E Main Ave	East/West	Principal Arterial (east of Shaw Rd E)	3-5	35 (east of 15 th St SE)	No	Intermittent	None
		Minor Arterial (west of Shaw Rd E)		30 (west of 15 th St SE)			
Shaw Road E	North/South	Principal Arterial	4-5	35	No	Both Sides	None
2 nd St NE	North/South	Principal Arterial	2	30	No	Both Sides	None
5 th St NE	North/South	Minor Arterial	2-3	30	Intermittent	Both Sides	Sharrows
15 th St SE	North/South	Minor Arterial	4	30	No	Both Sides	None
E Pioneer Way	East/West	Principal Arterial	2-3	25	No	South Side	No

Study Intersections

The City of Puyallup requires a detailed traffic analysis at intersections impacted by 25 or more peak hour project trips. Based on this requirement and scoping correspondence provided by the City of Puyallup, the following ten (10) study intersections were included in this traffic study:

1. 2nd Street NE / E Main Ave
2. 5th Street SE / E Main Ave
3. SR 512 Eastbound (EB) Ramps / E Pioneer Way
4. 15th Street SE / E Pioneer Way
5. 15th Street SE / E Main Ave
6. Linden Lane Apartment Driveway / E Main Ave / Future Site Access
7. Shaw Road E / E Main Ave
8. Shaw Road E / E Pioneer Way
9. SR 410 Eastbound (EB) Ramps / E Main Ave
10. SR 410 Westbound (WB) Ramps / E Main Ave

Existing Traffic Volumes

Existing weekday PM peak hour traffic volumes at the study intersections were based on traffic counts conducted in March 2022. The PM peak hour represents the highest one-hour time period between 4:00 and 6:00 PM. **Appendix A** includes the existing peak hour traffic count sheets.

The 2022 existing weekday PM peak hour traffic volumes at the study intersections are illustrated in **Figure 3**.

Public Transportation Services

Pierce Transit provides public transportation services in the immediate vicinity of the proposed project. Route 409 is currently located across from the *2504 E Main Ave* site access approximately 100 feet west of the Linden Lane Apartment Driveway.

Route 409 offers weekday and weekend transit service from the 72nd Street Transit Center to 29th St NE / 5th Ave NE in Puyallup. The current schedule for Route 409 includes approximately 60-minute headways from 9:20 a.m. to 5:20 p.m. on a typical weekday.

Non-motorized Transportation Facilities

Non-motorized transportation facilities in the project site vicinity are limited and include intermittent sidewalks along E Main Ave. Pedestrian crosswalks are typically provided at most signalized study intersections in the project vicinity. Based on traffic counts conducted at the study intersections, there is minimal pedestrian activity in the site vicinity.

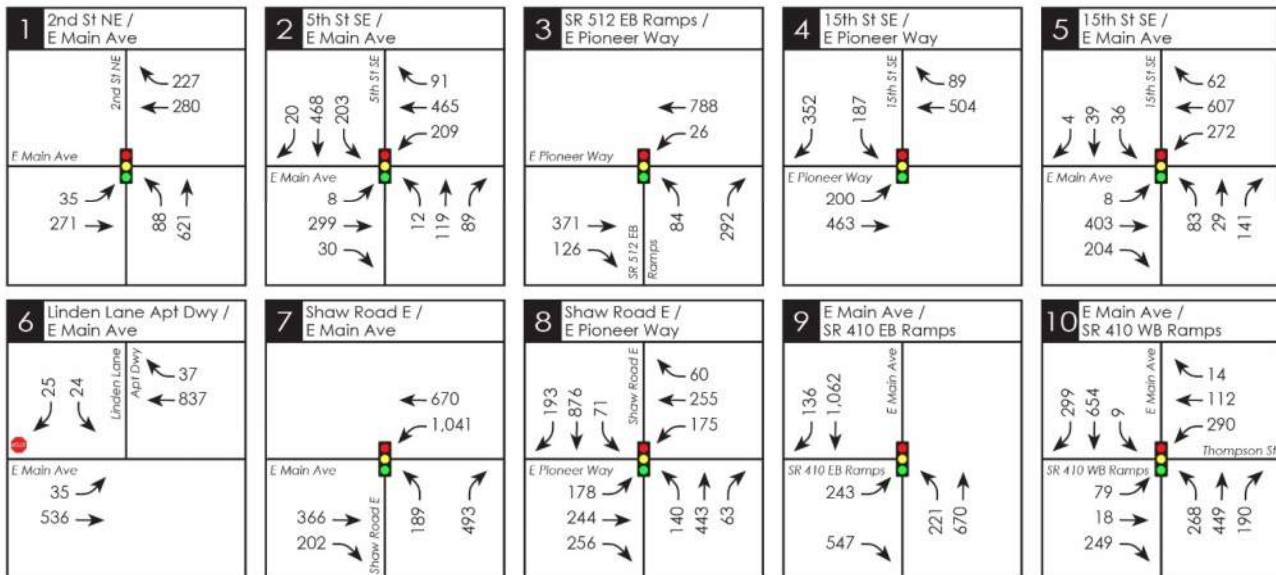
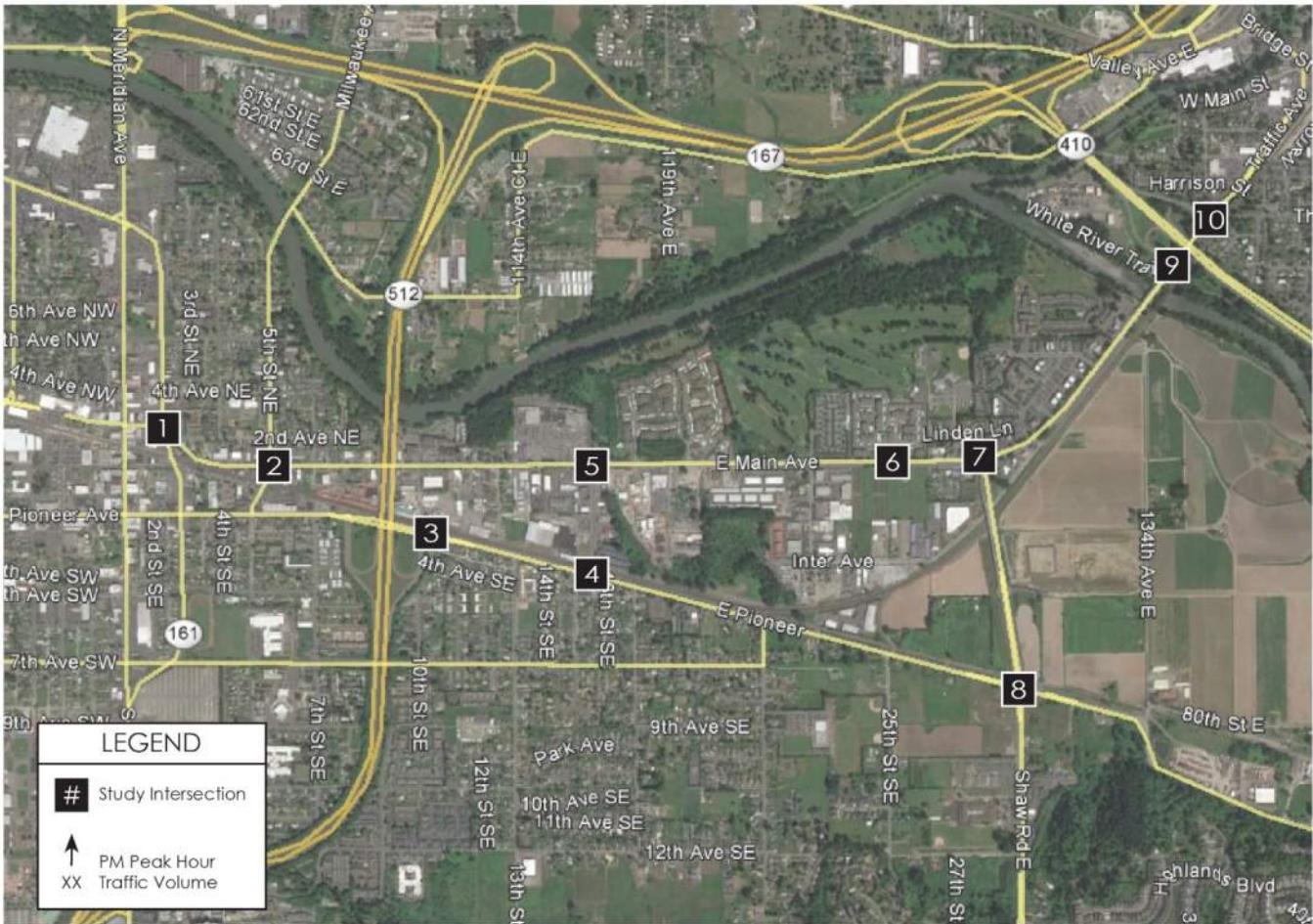

Figure 3: Year 2022 Existing Weekday PM Peak Hour Traffic Volumes



Level of Service

Based on scoping correspondence provided by the City of Puyallup, existing weekday PM peak hour level of service (LOS) analyses were conducted at ten (10) study intersections.

LOS generally refers to the degree of congestion on a roadway or intersection. It is a measure of vehicle operating speed, travel time, travel delays, and driving comfort. A letter scale from A to F generally describes intersection LOS. At signalized intersections, LOS A represents free-flow conditions (motorists experience little or no delays), and LOS F represents forced-flow conditions where motorists experience an average delay that exceeds 80 seconds per vehicle.

The LOS reported for signalized intersections represents the average control delay (sec/veh) and can be reported for the overall intersection, for each approach, and for each lane group (additional v/c ratio criteria apply to lane group LOS only).

The LOS reported at stop-controlled intersections is based on the average control delay and can be reported for each controlled minor approach, controlled minor lane group, and controlled major-street movement (and for the overall intersection at all-way stop controlled intersections. Additional v/c ratio criteria apply to lane group or movement LOS only). **Table 2** outlines the current HCM 6th Edition LOS criteria for signalized and stop-controlled intersections based on these methodologies.

Table 2
LOS Criteria for Signalized and Stop-Controlled Intersections¹

SIGNALIZED INTERSECTIONS			UNSIGNALIZED INTERSECTIONS		
Control Delay (sec/veh)	LOS by Volume-to Capacity (V/C) Ratio ²		Control Delay (sec/veh)	LOS by Volume-to Capacity (V/C) Ratio ³	
	≤ 1.0	> 1.0		≤ 1.0	> 1.0
≤ 10	A	F	≤ 10	A	F
> 10 to ≤ 20	B	F	> 10 to ≤ 15	B	F
> 20 to ≤ 35	C	F	> 15 to ≤ 25	C	F
> 35 to ≤ 55	D	F	> 25 to ≤ 35	D	F
> 55 to ≤ 80	E	F	> 35 to ≤ 50	E	F
> 80	F	F	> 50	F	F

1) Source: Highway Capacity Manual, Transportation Research Board, 6th Edition, 2016.

2) For approach-based and intersection-wide assessments at signals, LOS is defined solely by control delay.

3) For unsignalized intersections, the LOS criteria apply to each lane on a given approach and to each approach on the minor street. LOS is not calculated for major-street approaches or for the intersection as a whole at two-way stop controlled intersections. For approach-based and intersection-wide assessments at all-way stop controlled intersections, LOS is solely defined by control delay.

Level of service calculations for intersections were based on methodology and procedures outlined in the 6th Edition of the *Highway Capacity Manual* using *Synchro 10* traffic analysis software. Existing signal timing used in the analysis was provided by the City of Puyallup and the Washington State Department of Transportation (WSDOT).

Based on the City of Puyallup and WSDOT's LOS standards, the LOS standard is LOS D at all study intersections.

The 2022 existing PM peak hour LOS analysis results for the study intersections are summarized in **Table 3** with detailed LOS worksheets included in **Appendix B**.

Table 3
2022 Existing PM Peak Hour Level of Service Summary

Study Intersection / Movement	PM Peak Hour	
	LOS	Delay (sec)
<i>Signalized Intersections:</i>		
1. 2 nd Street NE / E Main Ave	B	13.5
2. 5 th Street SE / E Main Ave	B	16.2
3. SR 512 EB Ramps / E Pioneer Way	B	14.5
4. 15 th Street SE / E Pioneer Way	C	31.5
5. 15 th Street SE / E Main Ave	A	9.3
7. Shaw Road E / E Main Ave	C	26.5
8. Shaw Road E / E Pioneer Way	D	37.2
9. SR 410 EB Ramps / E Main Ave	C	32.2
10. SR 410 WB Ramps / E Main Ave	C	23.1
<i>Stop-Controlled Intersections:</i>		
6. Linden Lane Apartment Dwy / E Main Ave		
Eastbound Left-Turn (E Main Ave)	B	10.3
Southbound Left-Turn (Apartment Dwy)	C	20.5
Southbound Right-Turn (Apartment Dwy)	B	12.1

As shown in **Table 3**, all signalized study intersections currently operate at LOS D or better (thus meeting the established LOS D standard) under 2022 existing PM peak hour conditions. Additionally, all controlled movements at the two-way stop controlled study intersection currently operate at acceptable LOS (LOS D or better) under 2022 existing PM peak hour conditions.

True Demand

Based on scoping correspondence provided by the City of Puyallup, existing weekday PM peak hour true demand was evaluated at the following four (4) study intersections:

- 2nd Street NE / E Main Ave (#1)
- 5th Street NE / E Main Ave (#2)
- Shaw Road E / E Main Ave (#7)
- Shaw Road E / E Pioneer Way (#8)

True demand is generally defined as the total number of vehicles arriving at an intersection during a given period of time. Unlike standard turning movement counts (TMCs) which count the number of vehicles that make a particular movement during a defined period, true demand counts include queued up vehicles that have not yet entered the intersection. In order to estimate the total number of vehicles waiting in a queue during the PM peak hour, the delta between true demand counts and turning movement counts was calculated (Total Vehicles in Queue = True Demand Counts – Turning Movement Counts).

The 2022 existing PM peak hour true demand and the vehicular queueing volume associated with each turning movement are summarized in **Table 4** below with detailed true demand calculations included in **Appendix C**.

Table 4
Future 2022 PM Peak Hour True Demand Summary

Study Intersection / Movement	True Demand Counts (veh)	Turning Movement Counts (veh)	Total Vehicles in Queue (veh)
1. 2 nd Street NE / E Main Ave			
Eastbound Left	35	35	0
Eastbound Thru	274	271	3
Westbound Thru	306	280	26
Westbound Right	234	227	7
Northbound Left	90	88	2
Northbound Thru	629	621	8
2. 5 th Street SE / E Main Ave			
Eastbound Left	8	8	0
Eastbound Thru	317	299	18
Eastbound Right	34	30	4
Westbound Left	221	209	12
Westbound Thru	476	465	11
Westbound Right	95	91	4
Northbound Left	12	12	0
Northbound Thru	122	119	3
Northbound Right	92	89	3
Southbound Left	210	203	7
Southbound Thru	500	468	32
Southbound Right	22	20	2
7. Shaw Road E / E Main Ave			
Eastbound Thru	384	366	18
Eastbound Right	207	202	5
Westbound Left	1,130	1,041	89
Westbound Thru	704	670	34
Northbound Left	197	189	8
Northbound Right	510	493	17
8. Shaw Road E / E Pioneer Way			
Eastbound Left	197	178	19
Eastbound Thru	248	244	4
Eastbound Right	265	256	9
Westbound Left	185	175	10
Westbound Thru	268	255	13
Westbound Right	65	60	5
Northbound Left	150	140	10
Northbound Thru	467	443	24
Northbound Right	63	63	0
Southbound Left	80	71	9
Southbound Thru	1,001	876	125
Southbound Right	220	193	27

It should be noted that the volumes in **Table 4** are summarized by movement and are not associated with an individual lane. For example, at the intersection of Shaw Road E/E Pioneer Way, the northbound approach channelization includes dual northbound left-turn lanes, one northbound thru lane, and one shared northbound thru-right-turn lane. However, the northbound true demand at the intersection is summarized by the available northbound turn movements (left-turn, thru, and right-turn).

WITH PROJECT CONDITIONS

Project Trip Generation

Trip generation estimates for the proposed manufacturing use were based on methodology documented in the ITE *Trip Generation Manual*, 11th Edition for Land Use Code (LUC 140 (Manufacturing)). Truck trips associated with the proposed manufacturing use were estimated separately based on truck trip rates also documented in the ITE *Trip Generation Manual* (11th Edition, 2021) for LUC 140.

The resulting new weekday daily, AM peak hour, and PM peak hour trip generation estimates are summarized in **Table 5**. The detailed trip generation calculations are included in **Appendix D**.

Table 5
Project Trip Generation Summary

Weekday Time Period	New Trips Generated								
	Non-Truck Trips			Truck Trips			Total Trips		
	In	Out	Total	In	Out	Total	In	Out	Total
Daily	452	452	904	47	48	95	499	500	999
AM Peak Hour	106	31	137	3	3	6	109	34	143
PM Peak Hour	46	104	150	2	4	6	48	108	156

As shown in **Table 5**, the *2504 E Main Ave* project is estimated to generate 999 new weekday daily trips, with 143 new trips occurring during the weekday AM peak hour (109 in, 34 out) and 156 new trips occurring during the weekday PM peak hour (48 in, 108 out).

Project Trip Distribution and Assignment

The general distribution of *2504 E Main Ave* peak hour project trips was estimated separately for non-trucks (passenger vehicles) and trucks based on existing traffic volumes, the location of population and employment areas in the site vicinity, the type of use that is proposed, and designated truck/heavy haul routes in the project vicinity. The anticipated trip distribution patterns for both non-trucks (passenger vehicles) and trucks are illustrated graphically in **Figure 4** and were approved by the City of Puyallup in scoping discussions.

Based on the trip distribution percentages shown in **Figure 4**, the new weekday PM peak hour project trips for the *2504 E Main Ave* project were assigned separately for non-trucks and trucks to the streets in the project vicinity. The resulting assignment of the new weekday PM peak hour passenger (non-truck) and truck project trips is shown in **Figure 4**.

Future Traffic Volumes

Year 2022 With Project PM peak hour traffic volumes were estimated by adding the peak hour trip assignment from the proposed development (shown in **Figure 4**) to the existing peak hour traffic volumes (shown in **Figure 3**). The 2022 With Project PM peak hour traffic volumes at the study intersections are shown in **Figure 5**.

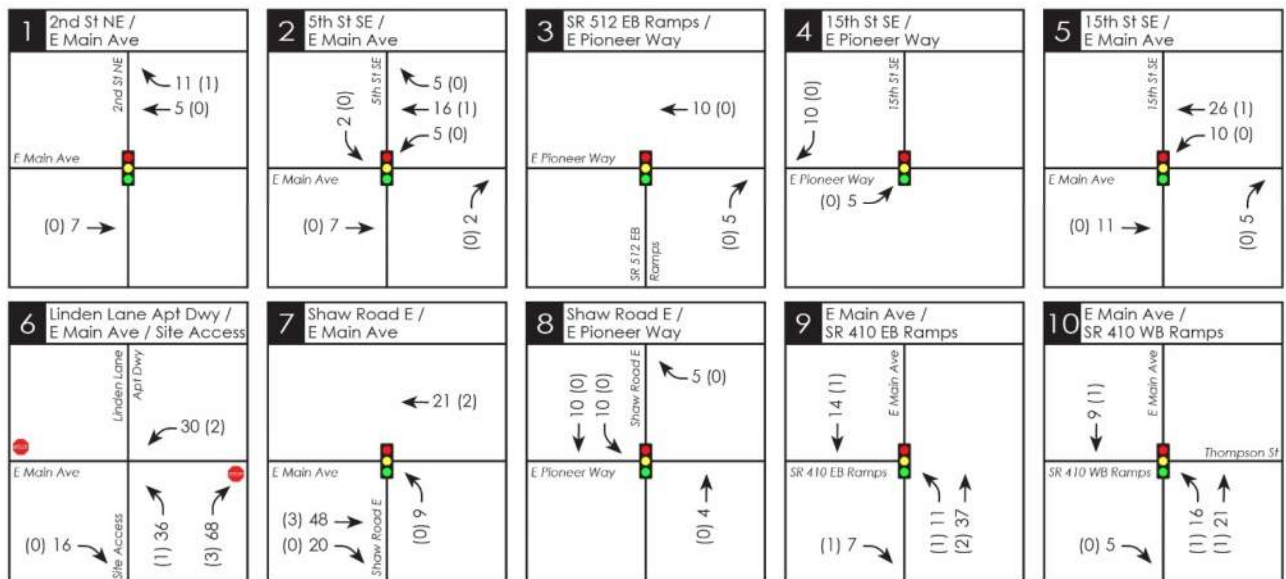
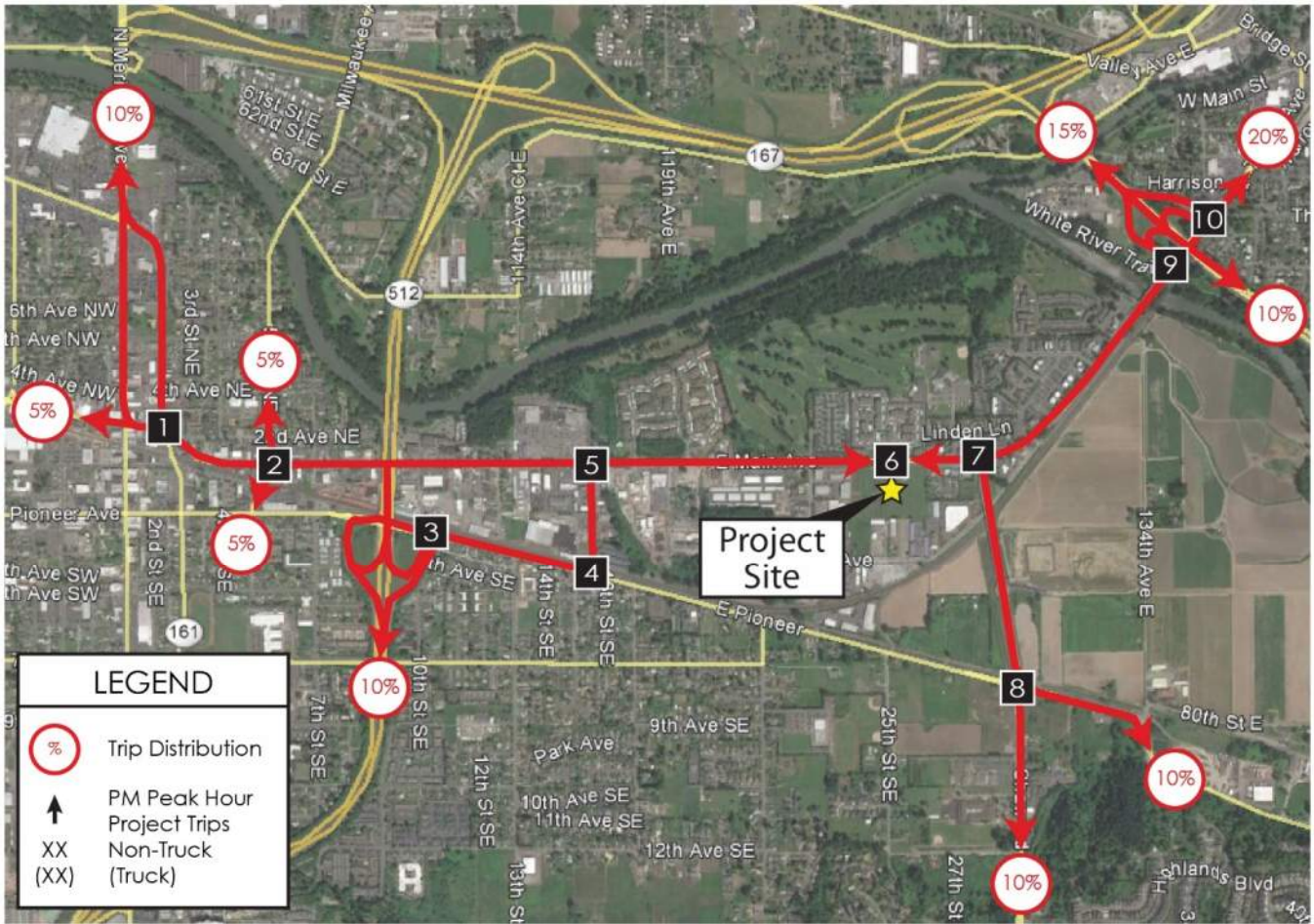

Figure 4: Weekday PM Peak Hour Project Trip Distribution and Assignment



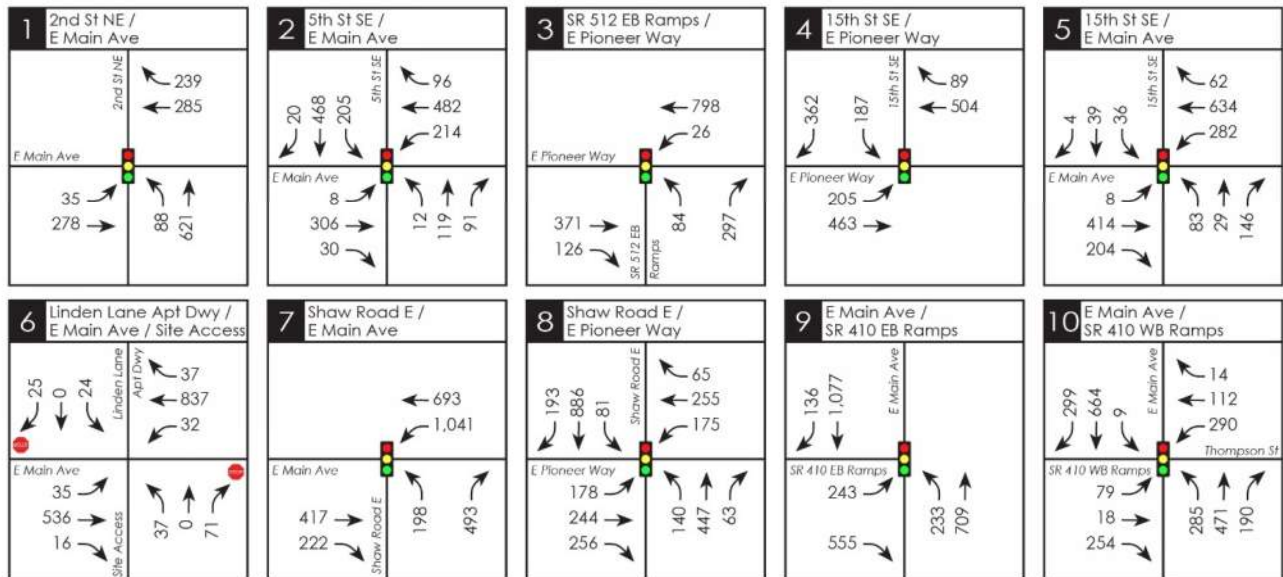
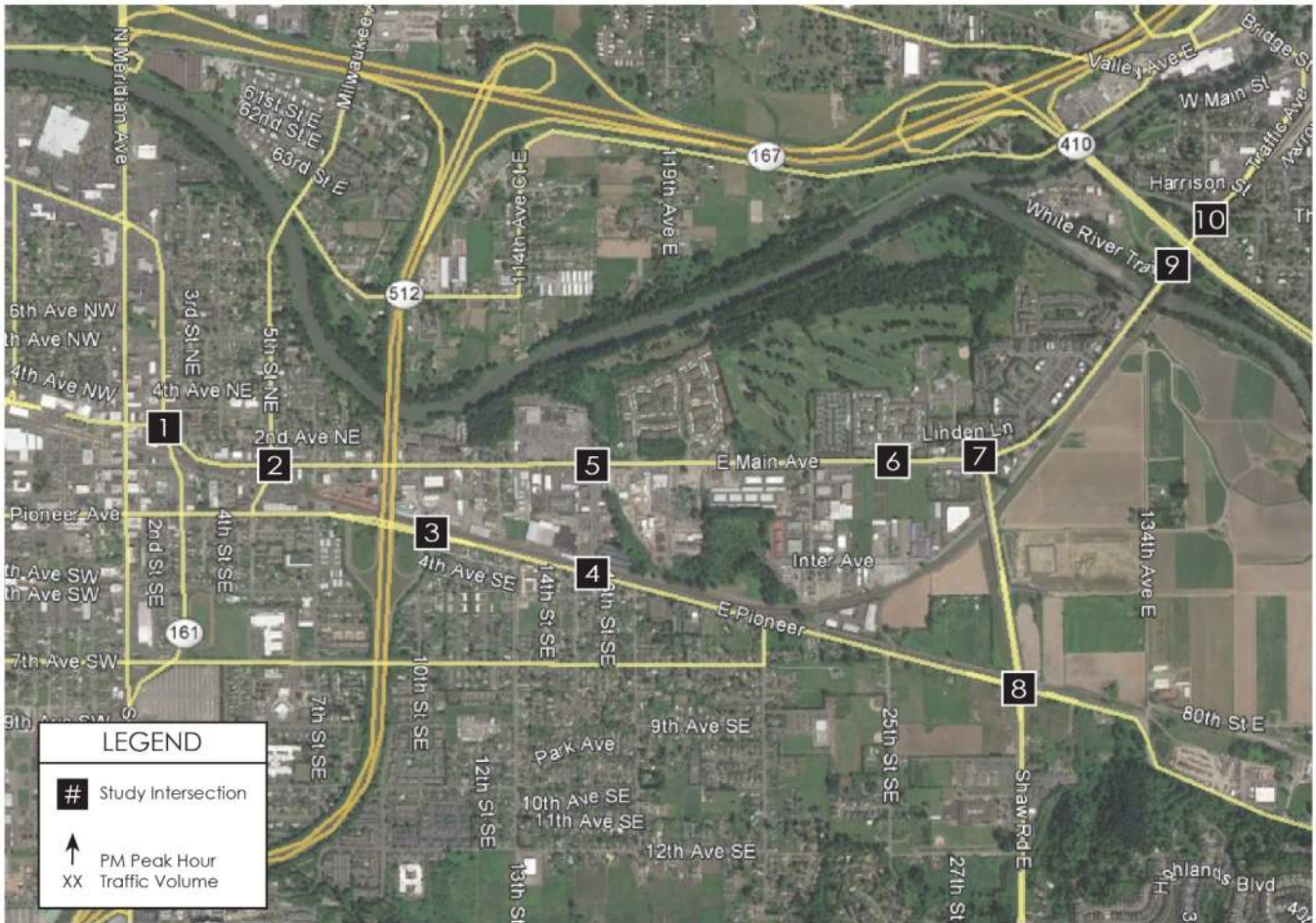

Figure 5: Year 2022 With Project Weekday PM Peak Hour Traffic Volumes



Level of Service at Study Intersections

Year 2022 level of service (LOS) analyses were conducted at the 10 study intersections for weekday PM peak hour With Project conditions. The roadway network and signal timing assumed in the With Project LOS analyses was based on existing conditions.

The 2022 weekday PM peak hour LOS results at the study intersections with the proposed *2504 E Main Ave* project are summarized in **Table 6**. The LOS worksheets are included in **Appendix B**.

Table 6
2022 With Project PM Peak Hour Level of Service Summary

Study Intersection / Movement	With Project PM Peak Hour	
	LOS	Delay (sec)
<u>Signalized Intersections:</u>		
1. 2 nd Street NE / E Main Ave	B	13.7
2. 5 th Street SE / E Main Ave	B	16.5
3. SR 512 EB Ramps / E Pioneer Way	B	14.6
4. 15 th Street SE / E Pioneer Way	C	31.8
5. 15 th Street SE / E Main Ave	A	9.4
7. Shaw Road E / E Main Ave	C	28.2
8. Shaw Road E / E Pioneer Way	D	37.8
9. SR 410 EB Ramps / E Main Ave	D	38.3
10. SR 410 WB Ramps / E Main Ave	C	23.3
<u>Stop-Controlled Intersections:</u>		
6. Linden Lane Apartment Dwy / E Main Ave / Site Access		
Eastbound Left-Turn (E Main Ave)	B	10.3
Westbound Left-Turn (E Main Ave)	A	8.9
Northbound Left-Thru-Right (Site Dwy)	C	16.2
Southbound Left-Turn (Apartment Dwy)	D	27.4
Southbound Right-Turn (Apartment Dwy)	B	12.1

As shown in **Table 6**, all signalized study intersections are anticipated to meet the established LOS standard (LOS D) under 2022 With Project conditions during the weekday PM peak hour. Additionally, all controlled movements at the two-way stop controlled site access study intersection are anticipated to meet the established LOS standard (LOS D or better) under 2022 With Project conditions during the weekday PM peak hour.

Site Access Operations

Primary vehicular access to the *2504 E Main Ave* project site would be provided via a new south leg to the existing E Main Ave/Linden Lane Apartment Driveway intersection. The site access operations documented in this section includes a level of service analysis, signal warrant analysis, and right-turn lane analysis for the primary site access intersection.

Level of Service as a Two-Way Stop-Controlled Intersection

As shown in **Table 6**, as a two-way stop-controlled intersection, all controlled movements at the E Main Ave/Linden Lane Apartment Driveway/Site Access unsignalized intersection are anticipated to operate at LOS D or better during the PM peak hour in 2022 with the *2504 E Main Ave* project.

Signal Warrant Analysis

A traffic signal warrant analysis was conducted at the E Main Ave/Site Access intersection for year 2022 conditions with the proposed project. Signal warrants were based on guidelines outlined in the US Department of Transportation/Federal Highway Administration *Manual on Uniform Traffic Control Devices* (MUTCD), 2009 Edition. Of the eight signal warrants outlined in the MUTCD, Warrant 1 (Eight-Hour Vehicular Volume), Warrant 2 (Four-Hour Vehicular Volume), and Warrant 3 (Peak Hour) were analyzed.

The volume criteria used in the signal warrant analysis was based on the assumption of a single-lane approach on the minor street (site access driveway) with a posted speed limit of 25 mph, and a 2-lane approach on the major street (E Main Ave) with a posted speed limit of 35 mph.

Traffic Volumes

The existing traffic volumes used in the signal warrant analysis were based on 72-hour (3-day) counts collected by IDAX on March 22-24, 2022 and weekday AM and PM peak hour turning movement counts collected at the E Main Ave/Site Access intersection on March 22, 2022.

Year 2022 With Project daily traffic volumes were estimated by adding the future traffic generated from the buildout of the *2504 E Main Ave* project to the 2022 Existing daily traffic volumes. The traffic volumes used in the signal warrant analysis are included in **Appendix E**.

Signal Warrant Analysis Results

The results of the 2022 signal warrant analysis are summarized in **Table 7**. Detailed signal warrant analysis worksheets are included in **Appendix E**.

Table 7
E Main Ave/Site Access Signal Warrant Analysis

Warrant	Warrant Met?
Warrant 1 – Eight Hour Vehicular Volume	
Condition A – Minimum Vehicular Volume	No
Condition B – Interruption of Continuous Traffic	No
Combination of Conditions A and B	No
Warrant Met?	No
Warrant 2 – Four Hour Vehicular Volume	
Warrant Met?	No
Warrant 3 – PM Peak Hour	
Category A – Southbound Approach (2-lane)	No
Category A – Northbound Approach (1-lane)	No
Category B	No
Warrant Met?	No

As shown in **Table 7**, based on 2022 traffic volumes with the *2504 E Main Ave* project, none of the warrants evaluated would be met at the site access intersection on E Main Ave.

Right Turn Lane Evaluation

Evaluation of the need for an eastbound right-turn lane was conducted at the site access intersection on E Main Ave based on Exhibit 1310-11 (right-turn lane guidelines) included in the WSDOT *Design Manual*.

Year 2022 With Project traffic volumes during the weekday PM peak hour used in the turn lane evaluation were shown previously in **Figure 7**. Based on the 2022 With Project traffic volumes, an eastbound right-turn lane would not be warranted at the site access intersection on E Main Ave. The WSDOT turn lane exhibit used in right-turn lane evaluation is included in **Appendix F**.

MITIGATION

Off-Site SEPA Improvements

Based on the results of the analysis shown in this report, no project-specific off-site transportation mitigation is proposed for concurrency or SEPA purposes.

Transportation Impact Fees

To mitigate long-term transportation impacts, the City administers a Transportation Impact Fee (TIF) to new developments to improve the transportation system to accommodate the higher travel demand added by new development. The net impact fee is calculated based on the project's proposed land use less an impact fee credit for the existing land use. The City's current adopted transportation impact fee is \$4,500 per PM peak hour trip. The preliminary estimated transportation impact fee for the proposed project totals **\$700,650** (\$4,500 X 155.7 net new PM peak hour trips). However, \$166,500 in transportation impact fees were paid for the previously approved warehouse use and should be applied as credit for the proposed change in use to manufacturing. Therefore, the net new impact fees owed with the proposed *2504 E Main Ave* project is **\$534,150** (\$700,650 - \$166,500). Fees are subject to change, and the final impact fee calculation will be based on the rates and project size in effect at the time of building permit issuance.

Appendix A

Existing Peak Hour Turning Movement Count Sheets

2nd St NE E Stewart Ave



Date: 03/22/2022
Count Period: 4:00 PM to 6:00 PM
Peak Hour: 4:15 PM to 5:15 PM

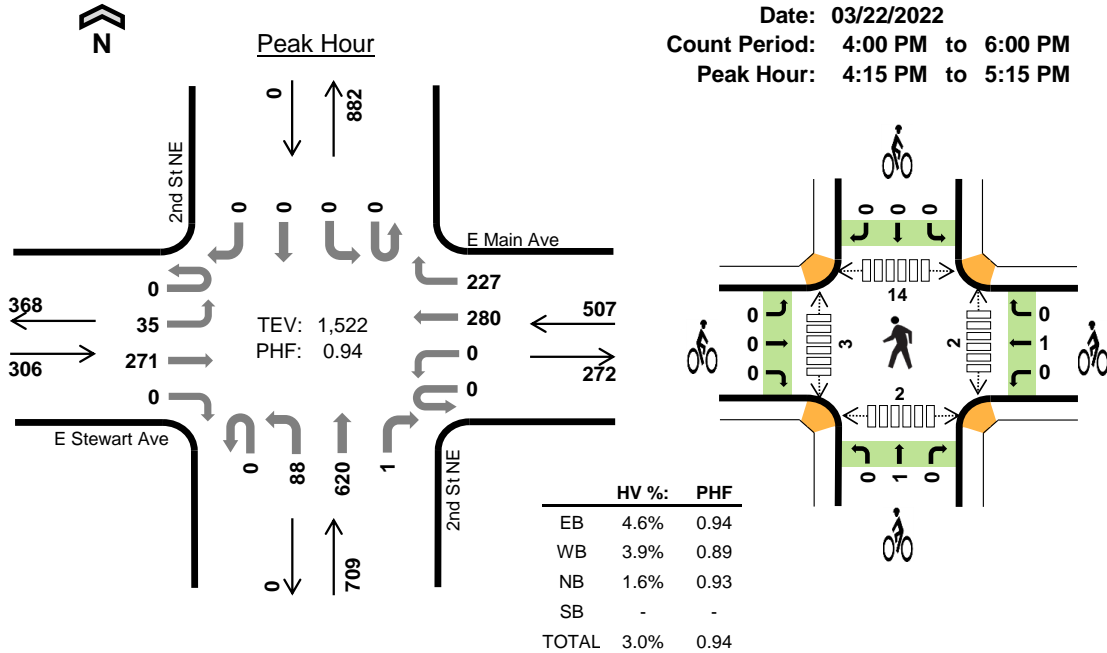

Two-Hour Count Summaries

Interval Start	E Stewart Ave				E Main Ave				2nd St NE Northbound				2nd St NE Southbound				15-min Total	Rolling One Hour	
	UT	LT	TH	RT	UT	LT	TH	RT	UT	LT	TH	RT	UT	LT	TH	RT			
4:00 PM	0	9	74	0	0	0	77	57	0	23	147	0	0	0	0	0	387	0	
4:15 PM	0	6	73	0	0	0	65	57	0	24	167	0	0	0	0	0	392	0	
4:30 PM	0	9	61	0	0	0	71	55	0	11	159	0	0	0	0	0	366	0	
4:45 PM	0	11	70	0	0	0	63	53	0	24	140	0	0	0	0	0	361	1,506	
5:00 PM	0	9	67	0	0	0	81	62	0	29	154	1	0	0	0	0	403	1,522	
5:15 PM	0	17	51	0	0	0	72	44	0	28	136	0	0	0	0	0	348	1,478	
5:30 PM	0	16	76	0	0	0	77	56	0	21	132	0	0	0	0	0	378	1,490	
5:45 PM	0	13	53	0	0	0	59	34	0	25	134	1	0	0	0	0	319	1,448	
Count Total	0	90	525	0	0	0	565	418	0	185	1,169	2	0	0	0	0	2,954	0	
Peak Hour	All	0	35	271	0	0	0	280	227	0	88	620	1	0	0	0	0	1,522	0
	HV	0	1	13	0	0	0	8	12	0	3	8	0	0	0	0	0	45	0
	HV%	-	3%	5%	-	-	-	3%	5%	-	3%	1%	0%	-	-	-	-	3%	0

Note: Two-hour count summary volumes include heavy vehicles but exclude bicycles in overall count.

Interval Start	Heavy Vehicle Totals					Bicycles					Pedestrians (Crossing Leg)					
	EB	WB	NB	SB	Total	EB	WB	NB	SB	Total	East	West	North	South	Total	
4:00 PM	5	9	5	0	19	0	0	0	0	0	0	1	0	0	4	5
4:15 PM	6	7	0	0	13	0	0	1	0	1	0	2	4	2	8	
4:30 PM	5	3	8	0	16	0	1	0	0	1	2	1	2	0	5	
4:45 PM	1	5	3	0	9	0	0	0	0	0	0	0	5	0	5	
5:00 PM	2	5	0	0	7	0	0	0	0	0	0	0	3	0	3	
5:15 PM	0	1	3	0	4	0	0	0	0	0	0	0	1	0	1	
5:30 PM	4	5	1	0	10	0	0	1	0	1	0	2	3	0	5	
5:45 PM	2	0	2	0	4	0	0	1	0	1	1	1	5	1	8	
Count Total	25	35	22	0	82	0	1	3	0	4	3	7	23	7	40	
Peak Hour	14	20	11	0	45	0	1	1	0	2	2	3	14	2	21	

Two-Hour Count Summaries - Heavy Vehicles																		
Interval Start	E Stewart Ave				E Main Ave				2nd St NE				2nd St NE				15-min Total	Rolling One Hour
	Eastbound				Westbound				Northbound				Southbound					
	UT	LT	TH	RT	UT	LT	TH	RT	UT	LT	TH	RT	UT	LT	TH	RT		
4:00 PM	0	2	3	0	0	0	8	1	0	2	3	0	0	0	0	0	19	0
4:15 PM	0	0	6	0	0	0	2	5	0	0	0	0	0	0	0	0	13	0
4:30 PM	0	0	5	0	0	0	1	2	0	2	6	0	0	0	0	0	16	0
4:45 PM	0	0	1	0	0	0	1	4	0	1	2	0	0	0	0	0	9	57
5:00 PM	0	1	1	0	0	0	4	1	0	0	0	0	0	0	0	0	7	45
5:15 PM	0	0	0	0	0	0	1	0	0	0	3	0	0	0	0	0	4	36
5:30 PM	0	0	4	0	0	0	1	4	0	1	0	0	0	0	0	0	10	30
5:45 PM	0	0	2	0	0	0	0	0	0	1	1	0	0	0	0	0	4	25
Count Total	0	3	22	0	0	0	18	17	0	7	15	0	0	0	0	0	82	0
Peak Hour	0	1	13	0	0	0	8	12	0	3	8	0	0	0	0	0	45	0

Two-Hour Count Summaries - Bikes																		
Interval Start	E Stewart Ave			E Main Ave			2nd St NE			2nd St NE			15-min Total	Rolling One Hour				
	Eastbound			Westbound			Northbound			Southbound								
	LT	TH	RT	LT	TH	RT	LT	TH	RT	LT	TH	RT						
4:00 PM	0	0	0	0	0	0	0	0	0	0	0	0	0	0	0	0	0	0
4:15 PM	0	0	0	0	0	0	0	0	0	1	0	0	0	0	0	0	1	0
4:30 PM	0	0	0	0	0	1	0	0	0	0	0	0	0	0	0	0	1	0
4:45 PM	0	0	0	0	0	0	0	0	0	0	0	0	0	0	0	0	0	2
5:00 PM	0	0	0	0	0	0	0	0	0	0	0	0	0	0	0	0	0	2
5:15 PM	0	0	0	0	0	0	0	0	0	0	0	0	0	0	0	0	0	1
5:30 PM	0	0	0	0	0	0	0	0	0	1	0	0	0	0	0	0	1	1
5:45 PM	0	0	0	0	0	0	0	0	0	1	0	0	0	0	0	0	1	2
Count Total	0	0	0	0	0	1	0	0	0	3	0	0	0	0	0	0	4	0
Peak Hour	0	0	0	0	0	1	0	0	0	1	0	0	0	0	0	0	2	0

Note: U-Turn volumes for bikes are included in Left-Turn, if any.

5th St NE E Main Ave



Peak Hour

Date: 03/22/2022
Count Period: 4:00 PM to 6:00 PM
Peak Hour: 4:00 PM to 5:00 PM

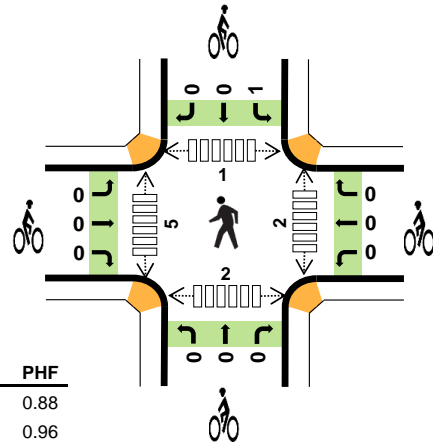
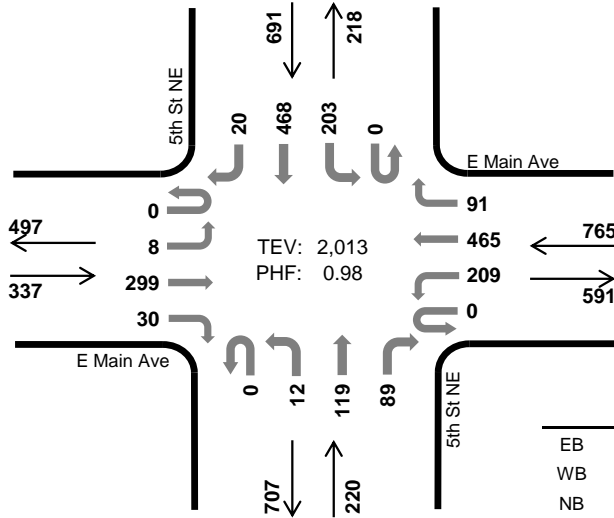

	HV %:	PHF
EB	4.5%	0.88
WB	3.4%	0.96
NB	1.8%	0.93
SB	3.9%	0.90
TOTAL	3.6%	0.98

Two-Hour Count Summaries

Interval Start	E Main Ave Eastbound				E Main Ave Westbound				5th St NE Northbound				5th St NE Southbound				15-min Total	Rolling One Hour	
	UT	LT	TH	RT	UT	LT	TH	RT	UT	LT	TH	RT	UT	LT	TH	RT			
4:00 PM	0	1	79	7	0	53	111	20	0	4	26	29	0	53	124	4	511	0	
4:15 PM	0	1	86	9	0	51	124	24	0	4	32	14	0	43	104	5	497	0	
4:30 PM	0	2	59	9	0	55	114	22	0	2	30	22	0	57	130	5	507	0	
4:45 PM	0	4	75	5	0	50	116	25	0	2	31	24	0	50	110	6	498	2,013	
5:00 PM	0	2	72	14	0	65	114	36	0	2	28	19	0	53	91	9	505	2,007	
5:15 PM	0	1	57	11	0	52	111	27	0	2	33	26	0	60	91	8	479	1,989	
5:30 PM	0	4	75	10	0	53	102	16	0	7	24	23	0	40	65	5	424	1,906	
5:45 PM	0	0	68	7	0	41	98	20	0	5	23	26	0	35	53	3	379	1,787	
Count Total	0	15	571	72	0	420	890	190	0	28	227	183	0	391	768	45	3,800	0	
Peak Hour	All	0	8	299	30	0	209	465	91	0	12	119	89	0	203	468	20	2,013	0
	HV	0	0	14	1	0	5	20	1	0	0	4	0	0	8	17	2	72	0
	HV%	-	0%	5%	3%	-	2%	4%	1%	-	0%	3%	0%	-	4%	4%	10%	4%	0

Note: Two-hour count summary volumes include heavy vehicles but exclude bicycles in overall count.

Interval Start	Heavy Vehicle Totals					Bicycles					Pedestrians (Crossing Leg)				
	EB	WB	NB	SB	Total	EB	WB	NB	SB	Total	East	West	North	South	Total
4:00 PM	3	7	1	6	17	0	0	0	0	0	0	1	1	1	3
4:15 PM	5	9	1	8	23	0	0	0	1	1	0	0	0	0	0
4:30 PM	5	3	1	7	16	0	0	0	0	0	1	3	0	1	5
4:45 PM	2	7	1	6	16	0	0	0	0	0	1	1	0	0	2
5:00 PM	1	5	0	0	6	0	0	0	0	0	0	1	0	4	5
5:15 PM	0	5	0	3	8	0	0	0	0	0	1	5	2	5	13
5:30 PM	3	3	0	0	6	0	0	0	0	0	2	1	1	0	4
5:45 PM	1	0	0	2	3	0	0	0	0	0	0	0	0	0	0
Count Total	20	39	4	32	95	0	0	0	1	1	5	12	4	11	32
Peak Hour	15	26	4	27	72	0	0	0	1	1	2	5	1	2	10

Two-Hour Count Summaries - Heavy Vehicles																		
Interval Start	E Main Ave				E Main Ave				5th St NE				5th St NE				15-min Total	Rolling One Hour
	Eastbound				Westbound				Northbound				Southbound					
	UT	LT	TH	RT	UT	LT	TH	RT	UT	LT	TH	RT	UT	LT	TH	RT		
4:00 PM	0	0	3	0	0	0	6	1	0	0	1	0	0	3	2	1	17	0
4:15 PM	0	0	5	0	0	2	7	0	0	0	1	0	0	2	6	0	23	0
4:30 PM	0	0	4	1	0	0	3	0	0	0	1	0	0	2	5	0	16	0
4:45 PM	0	0	2	0	0	3	4	0	0	0	1	0	0	1	4	1	16	72
5:00 PM	0	0	1	0	0	0	5	0	0	0	0	0	0	0	0	0	6	61
5:15 PM	0	0	0	0	0	0	5	0	0	0	0	0	0	2	1	0	8	46
5:30 PM	0	0	3	0	0	1	2	0	0	0	0	0	0	0	0	0	6	36
5:45 PM	0	0	1	0	0	0	0	0	0	0	0	0	0	2	0	0	3	23
Count Total	0	0	19	1	0	6	32	1	0	0	4	0	0	12	18	2	95	0
Peak Hour	0	0	14	1	0	5	20	1	0	0	4	0	0	8	17	2	72	0

Two-Hour Count Summaries - Bikes																	
Interval Start	E Main Ave			E Main Ave			5th St NE			5th St NE			15-min Total	Rolling One Hour			
	Eastbound			Westbound			Northbound			Southbound							
	LT	TH	RT	LT	TH	RT	LT	TH	RT	LT	TH	RT					
4:00 PM	0	0	0	0	0	0	0	0	0	0	0	0	0	0			
4:15 PM	0	0	0	0	0	0	0	0	0	1	0	0	1	0			
4:30 PM	0	0	0	0	0	0	0	0	0	0	0	0	0	0			
4:45 PM	0	0	0	0	0	0	0	0	0	0	0	0	0	1			
5:00 PM	0	0	0	0	0	0	0	0	0	0	0	0	0	1			
5:15 PM	0	0	0	0	0	0	0	0	0	0	0	0	0	0			
5:30 PM	0	0	0	0	0	0	0	0	0	0	0	0	0	0			
5:45 PM	0	0	0	0	0	0	0	0	0	0	0	0	0	0			
Count Total	0	0	0	0	0	0	0	0	0	1	0	0	1	0			
Peak Hour	0	0	0	0	0	0	0	0	0	1	0	0	1	0			

Note: U-Turn volumes for bikes are included in Left-Turn, if any.

SR 512 NB Ramps E Pioneer



Peak Hour

Date: 03/22/2022
 Count Period: 4:00 PM to 6:00 PM
 Peak Hour: 4:15 PM to 5:15 PM

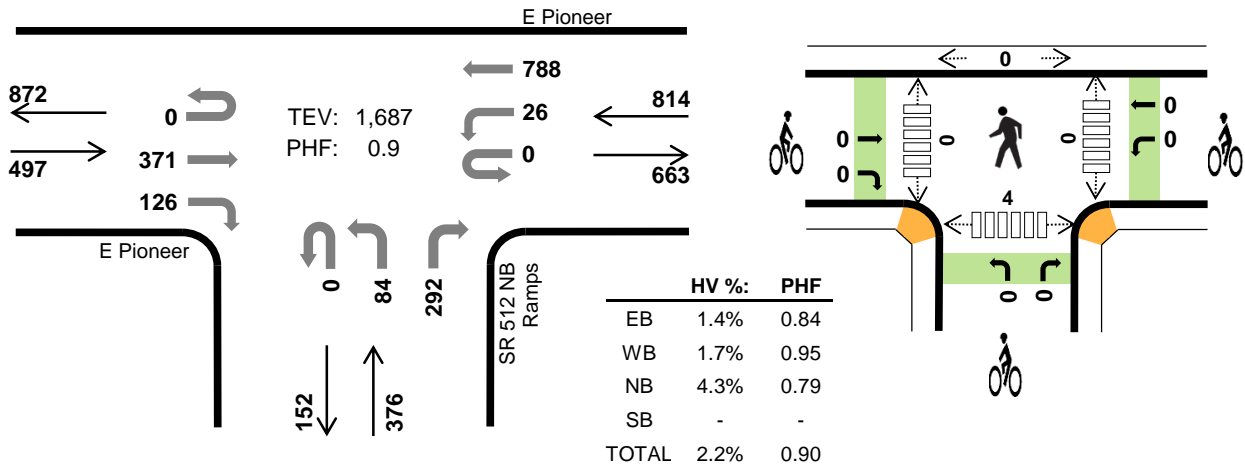

Two-Hour Count Summaries

Interval Start	E Pioneer Eastbound				E Pioneer Westbound				SR 512 NB Ramps Northbound				0 Southbound				15-min Total	Rolling One Hour	
	UT	LT	TH	RT	UT	LT	TH	RT	UT	LT	TH	RT	UT	LT	TH	RT			
4:00 PM	0	0	106	40	0	5	191	0	0	18	0	71	0	0	0	0	431	0	
4:15 PM	0	0	85	35	0	7	208	0	0	21	0	59	0	0	0	0	415	0	
4:30 PM	0	0	86	25	0	6	206	0	0	19	0	64	0	0	0	0	406	0	
4:45 PM	0	0	86	32	0	5	180	0	0	25	0	69	0	0	0	0	397	1,649	
5:00 PM	0	0	114	34	0	8	194	0	0	19	0	100	0	0	0	0	469	1,687	
5:15 PM	0	0	101	31	0	10	182	0	0	16	0	64	0	0	0	0	404	1,676	
5:30 PM	0	0	107	33	0	11	136	0	0	10	0	58	0	0	0	0	355	1,625	
5:45 PM	0	0	112	21	0	5	152	0	0	16	0	44	0	0	0	0	350	1,578	
Count Total	0	0	797	251	0	57	1,449	0	0	144	0	529	0	0	0	0	3,227	0	
Peak Hour	All	0	0	371	126	0	26	788	0	0	84	0	292	0	0	0	0	1,687	0
	HV	0	0	4	3	0	1	13	0	0	3	0	13	0	0	0	0	37	0
	HV%	-	-	1%	2%	-	4%	2%	-	-	4%	-	4%	-	-	-	-	2%	0

Note: Two-hour count summary volumes include heavy vehicles but exclude bicycles in overall count.

Interval Start	Heavy Vehicle Totals					Bicycles					Pedestrians (Crossing Leg)				
	EB	WB	NB	SB	Total	EB	WB	NB	SB	Total	East	West	North	South	Total
4:00 PM	7	1	3	0	11	0	0	0	0	0	0	0	0	8	8
4:15 PM	0	5	5	0	10	0	0	0	0	0	0	0	0	1	1
4:30 PM	2	4	0	0	6	0	0	0	0	0	0	0	0	2	2
4:45 PM	3	2	6	0	11	0	0	0	0	0	0	0	0	1	1
5:00 PM	2	3	5	0	10	0	0	0	0	0	0	0	0	0	0
5:15 PM	0	0	0	0	0	0	0	0	0	0	0	0	0	0	0
5:30 PM	1	2	1	0	4	0	0	0	0	0	0	0	0	1	1
5:45 PM	2	4	1	0	7	0	0	0	0	0	0	0	0	2	2
Count Total	17	21	21	0	59	0	0	0	0	0	0	0	0	15	15
Peak Hr	7	14	16	0	37	0	0	0	0	0	0	0	0	4	4

Two-Hour Count Summaries - Heavy Vehicles

Interval Start	E Pioneer				E Pioneer				SR 512 NB Ramps				0				15-min Total	Rolling One Hour
	Eastbound				Westbound				Northbound				Southbound					
	UT	LT	TH	RT	UT	LT	TH	RT	UT	LT	TH	RT	UT	LT	TH	RT		
4:00 PM	0	0	6	1	0	0	1	0	0	1	0	2	0	0	0	0	11	0
4:15 PM	0	0	0	0	0	0	5	0	0	2	0	3	0	0	0	0	10	0
4:30 PM	0	0	1	1	0	0	4	0	0	0	0	0	0	0	0	0	6	0
4:45 PM	0	0	2	1	0	0	2	0	0	1	0	5	0	0	0	0	11	38
5:00 PM	0	0	1	1	0	1	2	0	0	0	0	5	0	0	0	0	10	37
5:15 PM	0	0	0	0	0	0	0	0	0	0	0	0	0	0	0	0	0	27
5:30 PM	0	0	1	0	0	1	1	0	0	0	0	1	0	0	0	0	4	25
5:45 PM	0	0	1	1	0	0	4	0	0	0	0	1	0	0	0	0	7	21
Count Total	0	0	12	5	0	2	19	0	0	4	0	17	0	0	0	0	59	0
Peak Hour	0	0	4	3	0	1	13	0	0	3	0	13	0	0	0	0	37	0

Two-Hour Count Summaries - Bikes

Interval Start	E Pioneer			E Pioneer			SR 512 NB Ramps			0			15-min Total	Rolling One Hour
	Eastbound			Westbound			Northbound			Southbound				
	LT	TH	RT	LT	TH	RT	LT	TH	RT	LT	TH	RT		
4:00 PM	0	0	0	0	0	0	0	0	0	0	0	0	0	0
4:15 PM	0	0	0	0	0	0	0	0	0	0	0	0	0	0
4:30 PM	0	0	0	0	0	0	0	0	0	0	0	0	0	0
4:45 PM	0	0	0	0	0	0	0	0	0	0	0	0	0	0
5:00 PM	0	0	0	0	0	0	0	0	0	0	0	0	0	0
5:15 PM	0	0	0	0	0	0	0	0	0	0	0	0	0	0
5:30 PM	0	0	0	0	0	0	0	0	0	0	0	0	0	0
5:45 PM	0	0	0	0	0	0	0	0	0	0	0	0	0	0
Count Total	0	0	0	0	0	0	0	0	0	0	0	0	0	0
Peak Hour	0	0	0	0	0	0	0	0	0	0	0	0	0	0

Note: U-Turn volumes for bikes are included in Left-Turn, if any.

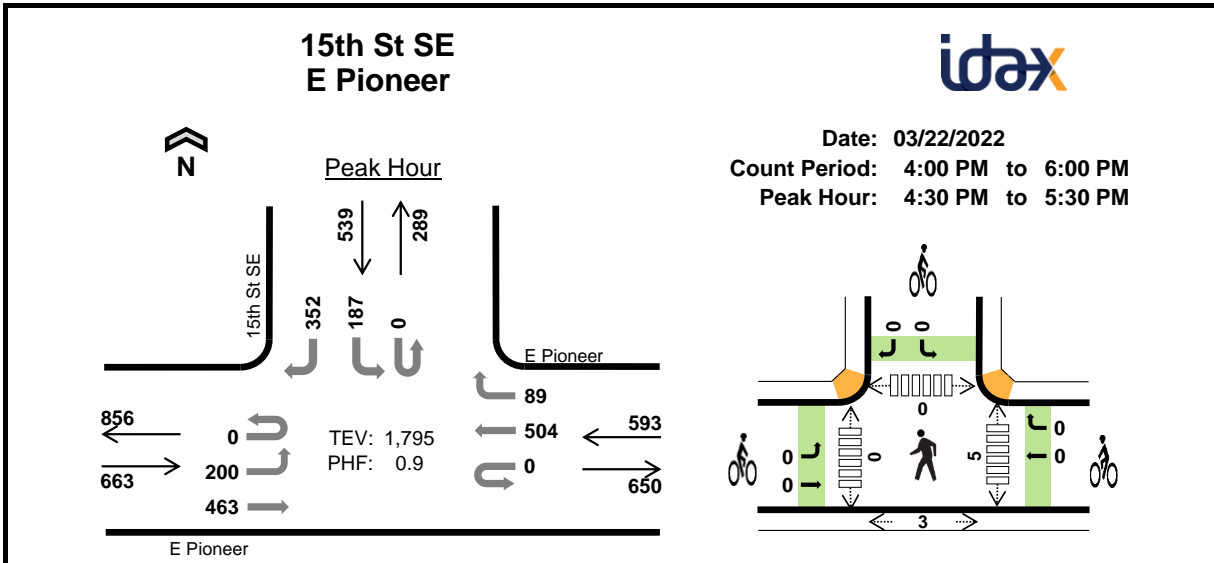

	HV %:	PHF
EB	2.6%	0.91
WB	1.7%	0.94
NB	-	-
SB	0.7%	0.84
TOTAL	1.7%	0.90

Two-Hour Count Summaries

Interval Start	E Pioneer Eastbound				E Pioneer Westbound				0 Northbound				15th St SE Southbound				15-min Total	Rolling One Hour	
	UT	LT	TH	RT	UT	LT	TH	RT	UT	LT	TH	RT	UT	LT	TH	RT			
4:00 PM	0	35	125	0	0	0	136	17	0	0	0	0	0	45	0	88	446	0	
4:15 PM	0	50	99	0	0	0	133	17	0	0	0	0	0	39	0	77	415	0	
4:30 PM	0	38	106	0	0	0	139	19	0	0	0	0	0	54	0	92	448	0	
4:45 PM	0	54	109	0	0	0	116	20	0	0	0	0	0	39	0	81	419	1,728	
5:00 PM	0	54	128	0	0	0	129	26	0	0	0	0	0	56	0	105	498	1,780	
5:15 PM	0	54	120	0	0	0	120	24	0	0	0	0	0	38	0	74	430	1,795	
5:30 PM	0	23	150	0	0	0	114	8	0	0	0	0	0	24	0	36	355	1,702	
5:45 PM	0	38	111	0	0	0	105	23	0	0	0	0	0	49	0	69	395	1,678	
Count Total	0	346	948	0	0	0	992	154	0	0	0	0	0	344	0	622	3,406	0	
Peak Hour	All	0	200	463	0	0	0	504	89	0	0	0	0	0	187	0	352	1,795	0
	HV	0	10	7	0	0	0	9	1	0	0	0	0	0	1	0	3	31	0
	HV%	-	5%	2%	-	-	-	2%	1%	-	-	-	-	-	1%	-	1%	2%	0

Note: Two-hour count summary volumes include heavy vehicles but exclude bicycles in overall count.

Interval Start	Heavy Vehicle Totals					Bicycles					Pedestrians (Crossing Leg)				
	EB	WB	NB	SB	Total	EB	WB	NB	SB	Total	East	West	North	South	Total
4:00 PM	8	4	0	0	12	0	0	0	0	0	1	0	0	0	1
4:15 PM	2	2	0	2	6	1	0	0	0	1	1	0	1	0	2
4:30 PM	2	4	0	1	7	0	0	0	0	0	1	0	0	0	1
4:45 PM	8	2	0	1	11	0	0	0	0	0	2	0	0	2	4
5:00 PM	5	4	0	1	10	0	0	0	0	0	2	0	0	1	3
5:15 PM	2	0	0	1	3	0	0	0	0	0	0	0	0	0	0
5:30 PM	1	2	0	0	3	0	0	0	0	0	1	0	0	1	2
5:45 PM	1	3	0	2	6	0	0	0	0	0	0	0	0	6	6
Count Total	29	21	0	8	58	1	0	0	0	1	8	0	1	10	19
Peak Hr	17	10	0	4	31	0	0	0	0	0	5	0	0	3	8

Two-Hour Count Summaries - Heavy Vehicles														15-min Total	Rolling One Hour			
Interval Start	E Pioneer				E Pioneer				0				15th St SE					
	Eastbound				Westbound				Northbound				Southbound					
	UT	LT	TH	RT	UT	LT	TH	RT	UT	LT	TH	RT	UT	LT	TH	RT		
4:00 PM	0	5	3	0	0	0	2	2	0	0	0	0	0	0	0	0	12	0
4:15 PM	0	1	1	0	0	0	2	0	0	0	0	0	0	0	0	2	6	0
4:30 PM	0	1	1	0	0	0	4	0	0	0	0	0	0	0	0	1	7	0
4:45 PM	0	5	3	0	0	0	2	0	0	0	0	0	0	0	0	1	11	36
5:00 PM	0	3	2	0	0	0	3	1	0	0	0	0	0	0	0	1	10	34
5:15 PM	0	1	1	0	0	0	0	0	0	0	0	0	0	1	0	0	3	31
5:30 PM	0	1	0	0	0	0	2	0	0	0	0	0	0	0	0	0	3	27
5:45 PM	0	1	0	0	0	0	3	0	0	0	0	0	0	0	0	2	6	22
Count Total	0	18	11	0	0	0	18	3	0	0	0	0	0	1	0	7	58	0
Peak Hour	0	10	7	0	0	0	9	1	0	0	0	0	0	1	0	3	31	0

Two-Hour Count Summaries - Bikes														15-min Total	Rolling One Hour			
Interval Start	E Pioneer			E Pioneer			0			15th St SE								
	Eastbound			Westbound			Northbound			Southbound								
	LT	TH	RT	LT	TH	RT	LT	TH	RT	LT	TH	RT						
4:00 PM	0	0	0	0	0	0	0	0	0	0	0	0	0	0	0	0	0	0
4:15 PM	0	1	0	0	0	0	0	0	0	0	0	0	0	0	0	0	1	0
4:30 PM	0	0	0	0	0	0	0	0	0	0	0	0	0	0	0	0	0	0
4:45 PM	0	0	0	0	0	0	0	0	0	0	0	0	0	0	0	0	0	1
5:00 PM	0	0	0	0	0	0	0	0	0	0	0	0	0	0	0	0	0	1
5:15 PM	0	0	0	0	0	0	0	0	0	0	0	0	0	0	0	0	0	0
5:30 PM	0	0	0	0	0	0	0	0	0	0	0	0	0	0	0	0	0	0
5:45 PM	0	0	0	0	0	0	0	0	0	0	0	0	0	0	0	0	0	0
Count Total	0	1	0	0	0	0	0	0	0	0	0	0	0	0	0	0	1	0
Peak Hour	0	0	0	0	0	0	0	0	0	0	0	0	0	0	0	0	0	0

Note: U-Turn volumes for bikes are included in Left-Turn, if any.

15th St SE E Main Ave



Date: 03/22/2022
 Count Period: 4:00 PM to 6:00 PM
 Peak Hour: 4:15 PM to 5:15 PM

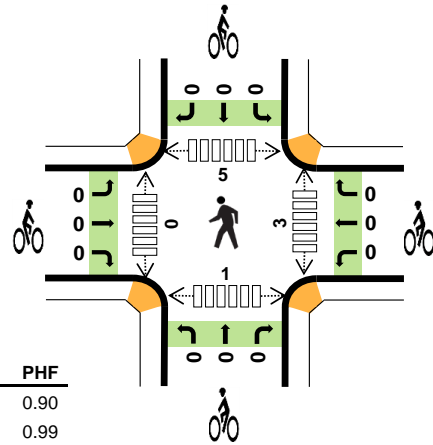
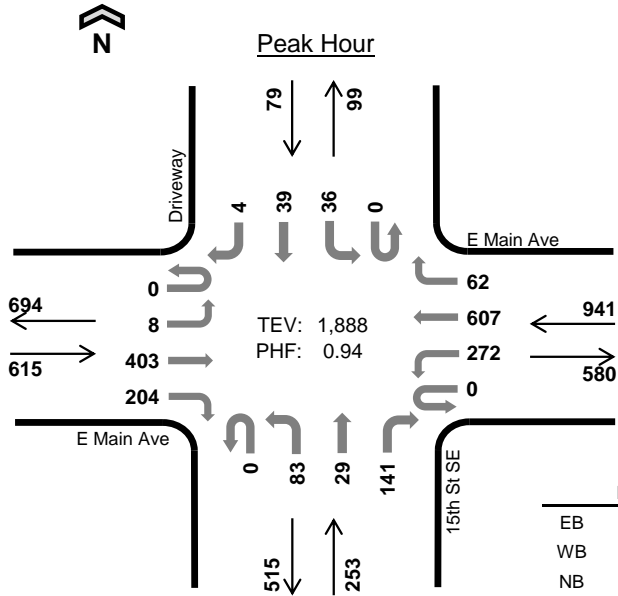

	HV %:	PHF
EB	2.8%	0.90
WB	2.3%	0.99
NB	4.0%	0.87
SB	2.5%	0.86
TOTAL	2.7%	0.94

Two-Hour Count Summaries

Interval Start	E Main Ave Eastbound				E Main Ave Westbound				15th St SE Northbound				Driveway Southbound				15-min Total	Rolling One Hour	
	UT	LT	TH	RT	UT	LT	TH	RT	UT	LT	TH	RT	UT	LT	TH	RT			
4:00 PM	0	2	120	39	0	77	148	19	0	18	6	27	0	15	10	3	484	0	
4:15 PM	0	1	101	46	0	63	150	19	0	18	11	34	0	8	13	1	465	0	
4:30 PM	0	4	101	42	0	70	154	13	0	20	8	27	0	8	8	1	456	0	
4:45 PM	0	3	94	52	0	70	154	13	0	22	4	36	0	10	5	2	465	1,870	
5:00 PM	0	0	107	64	0	69	149	17	0	23	6	44	0	10	13	0	502	1,888	
5:15 PM	0	1	93	42	0	57	139	11	0	18	8	43	0	17	9	3	441	1,864	
5:30 PM	0	0	109	48	0	63	128	10	0	29	1	34	0	5	7	0	434	1,842	
5:45 PM	0	2	102	29	0	53	109	7	0	12	10	31	0	5	13	0	373	1,750	
Count Total	0	13	827	362	0	522	1,131	109	0	160	54	276	0	78	78	10	3,620	0	
Peak Hour	All	0	8	403	204	0	272	607	62	0	83	29	141	0	36	39	4	1,888	0
	HV	0	0	17	0	0	2	17	3	0	4	0	6	0	1	0	1	51	0
	HV%	-	0%	4%	0%	-	1%	3%	5%	-	5%	0%	4%	-	3%	0%	25%	3%	0

Note: Two-hour count summary volumes include heavy vehicles but exclude bicycles in overall count.

Interval Start	Heavy Vehicle Totals					Bicycles					Pedestrians (Crossing Leg)				
	EB	WB	NB	SB	Total	EB	WB	NB	SB	Total	East	West	North	South	Total
4:00 PM	6	5	7	0	18	0	0	0	0	0	1	1	2	1	5
4:15 PM	5	8	1	0	14	0	0	0	0	0	0	0	1	0	1
4:30 PM	8	8	1	1	18	0	0	0	0	0	3	0	1	0	4
4:45 PM	1	3	3	0	7	0	0	0	0	0	0	0	1	0	1
5:00 PM	3	3	5	1	12	0	0	0	0	0	0	0	2	1	3
5:15 PM	2	5	1	1	9	0	0	0	0	0	6	0	0	3	9
5:30 PM	2	3	1	0	6	0	0	0	0	0	0	0	0	0	0
5:45 PM	1	2	0	0	3	0	0	0	0	0	2	0	0	0	2
Count Total	28	37	19	3	87	0	0	0	0	0	12	1	7	5	25
Peak Hour	17	22	10	2	51	0	0	0	0	0	3	0	5	1	9

Two-Hour Count Summaries - Heavy Vehicles																		
Interval Start	E Main Ave				E Main Ave				15th St SE				Driveway				15-min Total	Rolling One Hour
	Eastbound				Westbound				Northbound				Southbound					
	UT	LT	TH	RT	UT	LT	TH	RT	UT	LT	TH	RT	UT	LT	TH	RT		
4:00 PM	0	0	6	0	0	0	5	0	0	1	0	6	0	0	0	0	18	0
4:15 PM	0	0	5	0	0	1	7	0	0	0	0	1	0	0	0	0	14	0
4:30 PM	0	0	8	0	0	1	5	2	0	0	0	1	0	0	0	1	18	0
4:45 PM	0	0	1	0	0	0	3	0	0	1	0	2	0	0	0	0	7	57
5:00 PM	0	0	3	0	0	0	2	1	0	3	0	2	0	1	0	0	12	51
5:15 PM	0	0	1	1	0	0	4	1	0	0	0	1	0	1	0	0	9	46
5:30 PM	0	0	2	0	0	0	3	0	0	1	0	0	0	0	0	0	6	34
5:45 PM	0	0	1	0	0	2	0	0	0	0	0	0	0	0	0	0	3	30
Count Total	0	0	27	1	0	4	29	4	0	6	0	13	0	2	0	1	87	0
Peak Hour	0	0	17	0	0	2	17	3	0	4	0	6	0	1	0	1	51	0

Two-Hour Count Summaries - Bikes																		
Interval Start	E Main Ave			E Main Ave			15th St SE			Driveway			15-min Total	Rolling One Hour				
	Eastbound			Westbound			Northbound			Southbound								
	LT	TH	RT	LT	TH	RT	LT	TH	RT	LT	TH	RT						
4:00 PM	0	0	0	0	0	0	0	0	0	0	0	0	0	0	0	0	0	0
4:15 PM	0	0	0	0	0	0	0	0	0	0	0	0	0	0	0	0	0	0
4:30 PM	0	0	0	0	0	0	0	0	0	0	0	0	0	0	0	0	0	0
4:45 PM	0	0	0	0	0	0	0	0	0	0	0	0	0	0	0	0	0	0
5:00 PM	0	0	0	0	0	0	0	0	0	0	0	0	0	0	0	0	0	0
5:15 PM	0	0	0	0	0	0	0	0	0	0	0	0	0	0	0	0	0	0
5:30 PM	0	0	0	0	0	0	0	0	0	0	0	0	0	0	0	0	0	0
5:45 PM	0	0	0	0	0	0	0	0	0	0	0	0	0	0	0	0	0	0
Count Total	0	0	0	0	0	0	0	0	0	0	0	0	0	0	0	0	0	0
Peak Hour	0	0	0	0	0	0	0	0	0	0	0	0	0	0	0	0	0	0

Note: U-Turn volumes for bikes are included in Left-Turn, if any.

Apartment Driveway E Main Ave



Date: 03/22/2022
Count Period: 4:00 PM to 6:00 PM
Peak Hour: 4:00 PM to 5:00 PM

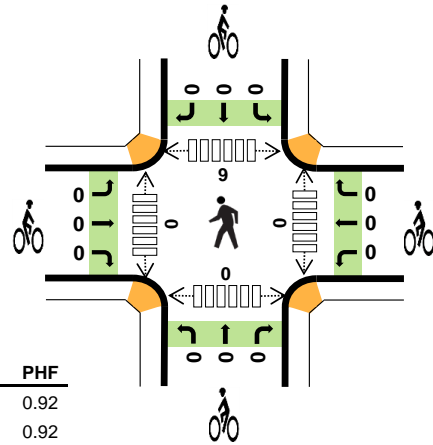
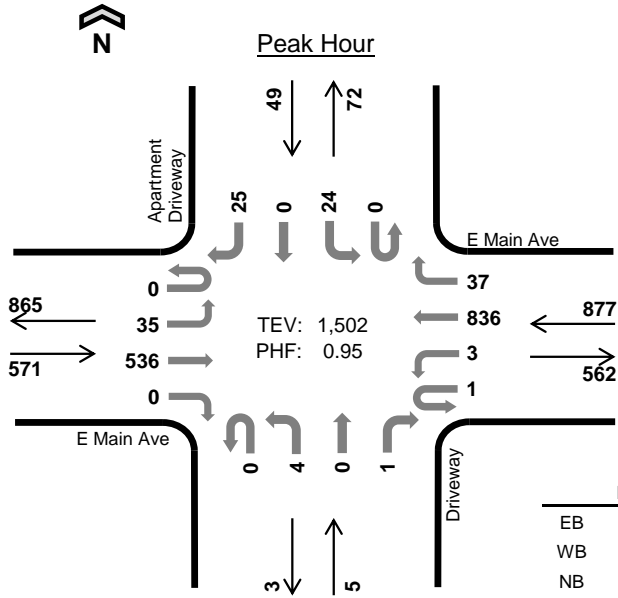

	HV %:	PHF
EB	2.5%	0.92
WB	3.3%	0.92
NB	0.0%	0.42
SB	8.2%	0.77
TOTAL	3.1%	0.95

Two-Hour Count Summaries

Interval Start	E Main Ave Eastbound				E Main Ave Westbound				Driveway Northbound				Apartment Driveway Southbound				15-min Total	Rolling One Hour	
	UT	LT	TH	RT	UT	LT	TH	RT	UT	LT	TH	RT	UT	LT	TH	RT			
4:00 PM	0	8	148	0	0	0	205	8	0	0	0	0	0	4	0	6	379	0	
4:15 PM	0	7	127	0	0	1	201	11	0	0	0	0	0	7	0	5	359	0	
4:30 PM	0	11	132	0	0	0	205	7	0	3	0	0	0	6	0	5	369	0	
4:45 PM	0	9	129	0	1	2	225	11	0	1	0	1	0	7	0	9	395	1,502	
5:00 PM	0	7	157	0	0	0	190	8	0	0	0	0	0	6	0	8	376	1,499	
5:15 PM	0	9	128	0	0	0	186	14	0	0	0	0	0	1	0	8	346	1,486	
5:30 PM	0	9	126	0	0	0	202	10	0	0	0	0	0	3	0	4	354	1,471	
5:45 PM	0	5	103	0	0	0	168	11	0	0	0	0	0	3	0	8	298	1,374	
Count Total	0	65	1,050	0	1	3	1,582	80	0	4	0	1	0	37	0	53	2,876	0	
Peak Hour	All	0	35	536	0	1	3	836	37	0	4	0	1	0	24	0	25	1,502	0
	HV	0	1	13	0	0	0	27	2	0	0	0	0	0	2	0	2	47	0
	HV%	-	3%	2%	-	0%	0%	3%	5%	-	0%	-	0%	-	8%	-	8%	3%	0

Note: Two-hour count summary volumes include heavy vehicles but exclude bicycles in overall count.

Interval Start	Heavy Vehicle Totals					Bicycles					Pedestrians (Crossing Leg)				
	EB	WB	NB	SB	Total	EB	WB	NB	SB	Total	East	West	North	South	Total
4:00 PM	8	8	0	1	17	0	0	0	0	0	0	0	4	0	4
4:15 PM	1	8	0	2	11	0	0	0	0	0	0	0	1	0	1
4:30 PM	4	6	0	1	11	0	0	0	0	0	0	0	3	0	3
4:45 PM	1	7	0	0	8	0	0	0	0	0	0	0	1	0	1
5:00 PM	5	3	0	1	9	0	0	0	0	0	0	0	1	0	1
5:15 PM	3	6	0	0	9	0	0	0	0	0	0	0	2	0	2
5:30 PM	2	3	0	0	5	0	0	0	0	0	0	0	1	0	1
5:45 PM	2	2	0	0	4	0	0	0	0	0	0	0	1	0	1
Count Total	26	43	0	5	74	0	0	0	0	0	0	0	14	0	14
Peak Hour	14	29	0	4	47	0	0	0	0	0	0	0	9	0	9

Two-Hour Count Summaries - Heavy Vehicles																		
Interval Start	E Main Ave				E Main Ave				Driveway				Apartment Driveway				15-min Total	Rolling One Hour
	Eastbound				Westbound				Northbound				Southbound					
	UT	LT	TH	RT	UT	LT	TH	RT	UT	LT	TH	RT	UT	LT	TH	RT		
4:00 PM	0	1	7	0	0	0	6	2	0	0	0	0	0	0	0	1	17	0
4:15 PM	0	0	1	0	0	0	8	0	0	0	0	0	0	0	1	0	11	0
4:30 PM	0	0	4	0	0	0	6	0	0	0	0	0	0	0	1	0	11	0
4:45 PM	0	0	1	0	0	0	7	0	0	0	0	0	0	0	0	0	8	47
5:00 PM	0	0	5	0	0	0	3	0	0	0	0	0	0	0	0	1	9	39
5:15 PM	0	0	3	0	0	0	6	0	0	0	0	0	0	0	0	0	9	37
5:30 PM	0	0	2	0	0	0	3	0	0	0	0	0	0	0	0	0	5	31
5:45 PM	0	0	2	0	0	0	2	0	0	0	0	0	0	0	0	0	4	27
Count Total	0	1	25	0	0	0	41	2	0	0	0	0	0	0	2	0	74	0
Peak Hour	0	1	13	0	0	0	27	2	0	0	0	0	0	0	2	0	47	0

Two-Hour Count Summaries - Bikes																		
Interval Start	E Main Ave			E Main Ave			Driveway			Apartment Driveway			15-min Total	Rolling One Hour				
	Eastbound			Westbound			Northbound			Southbound								
	LT	TH	RT	LT	TH	RT	LT	TH	RT	LT	TH	RT						
4:00 PM	0	0	0	0	0	0	0	0	0	0	0	0	0	0	0	0	0	0
4:15 PM	0	0	0	0	0	0	0	0	0	0	0	0	0	0	0	0	0	0
4:30 PM	0	0	0	0	0	0	0	0	0	0	0	0	0	0	0	0	0	0
4:45 PM	0	0	0	0	0	0	0	0	0	0	0	0	0	0	0	0	0	0
5:00 PM	0	0	0	0	0	0	0	0	0	0	0	0	0	0	0	0	0	0
5:15 PM	0	0	0	0	0	0	0	0	0	0	0	0	0	0	0	0	0	0
5:30 PM	0	0	0	0	0	0	0	0	0	0	0	0	0	0	0	0	0	0
5:45 PM	0	0	0	0	0	0	0	0	0	0	0	0	0	0	0	0	0	0
Count Total	0	0	0	0	0	0	0	0	0	0	0	0	0	0	0	0	0	0
Peak Hour	0	0	0	0	0	0	0	0	0	0	0	0	0	0	0	0	0	0

Note: U-Turn volumes for bikes are included in Left-Turn, if any.

Shaw Rd E E Main Ave



Peak Hour

Date: 03/22/2022

Count Period: 4:00 PM to 6:00 PM

Peak Hour: 4:30 PM to 5:30 PM

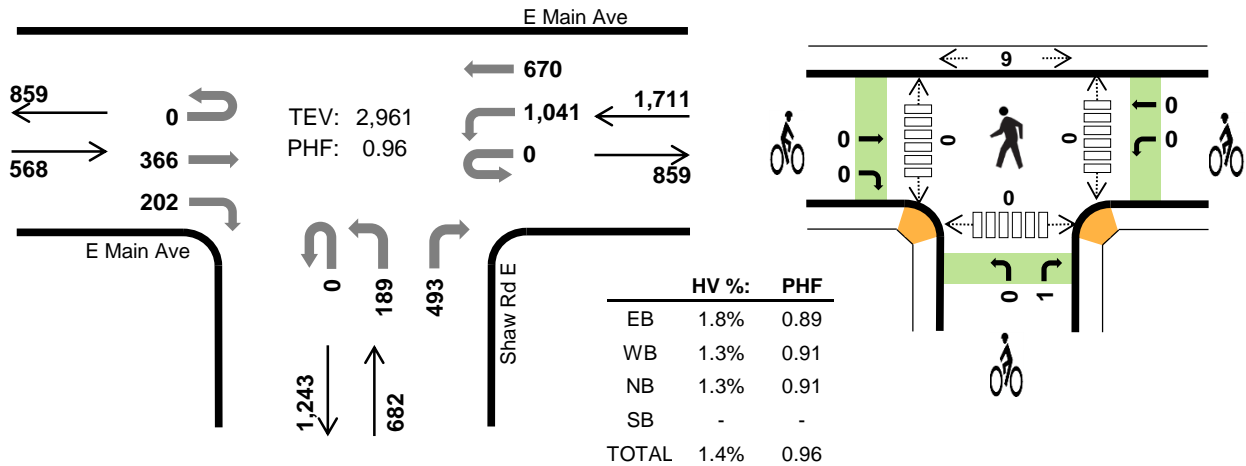

Two-Hour Count Summaries

Interval Start	E Main Ave Eastbound				E Main Ave Westbound				Shaw Rd E Northbound				Shaw Rd E Southbound				15-min Total	Rolling One Hour	
	UT	LT	TH	RT	UT	LT	TH	RT	UT	LT	TH	RT	UT	LT	TH	RT			
4:00 PM	0	0	108	48	0	212	178	0	0	41	0	111	0	0	0	0	698	0	
4:15 PM	0	0	90	42	0	189	160	0	0	62	0	120	0	0	0	0	663	0	
4:30 PM	0	0	89	55	0	232	157	0	0	52	0	135	0	0	0	0	720	0	
4:45 PM	0	0	87	56	0	282	188	0	0	48	0	111	0	0	0	0	772	2,853	
5:00 PM	0	0	104	55	0	256	166	0	0	42	0	128	0	0	0	0	751	2,906	
5:15 PM	0	0	86	36	0	271	159	0	0	47	0	119	0	0	0	0	718	2,961	
5:30 PM	0	0	80	47	0	205	167	0	0	49	0	121	0	0	0	0	669	2,910	
5:45 PM	0	0	70	44	0	190	119	0	0	51	0	95	0	0	0	0	569	2,707	
Count Total	0	0	714	383	0	1,837	1,294	0	0	392	0	940	0	0	0	0	5,560	0	
Peak Hour	All	0	0	366	202	0	1,041	670	0	0	189	0	493	0	0	0	0	2,961	0
	HV	0	0	7	3	0	11	12	0	0	5	0	4	0	0	0	0	42	0
	HV%	-	-	2%	1%	-	1%	2%	-	-	3%	-	1%	-	-	-	-	1%	0

Note: Two-hour count summary volumes include heavy vehicles but exclude bicycles in overall count.

Interval Start	Heavy Vehicle Totals					Bicycles					Pedestrians (Crossing Leg)				
	EB	WB	NB	SB	Total	EB	WB	NB	SB	Total	East	West	North	South	Total
4:00 PM	6	7	7	0	20	0	0	0	0	0	0	1	2	1	4
4:15 PM	2	5	5	0	12	0	0	0	0	0	0	1	2	0	3
4:30 PM	4	6	3	0	13	0	0	0	0	0	0	0	7	0	7
4:45 PM	1	4	1	0	6	0	0	0	0	0	0	0	2	0	2
5:00 PM	3	7	1	0	11	0	0	1	0	1	0	0	0	0	0
5:15 PM	2	6	4	0	12	0	0	0	0	0	0	0	0	0	0
5:30 PM	2	5	6	0	13	0	0	0	0	0	0	2	2	0	4
5:45 PM	0	3	2	0	5	0	0	0	0	0	0	5	7	0	12
Count Total	20	43	29	0	92	0	0	1	0	1	0	9	22	1	32
Peak Hr	10	23	9	0	42	0	0	1	0	1	0	0	9	0	9

Two-Hour Count Summaries - Heavy Vehicles

Interval Start	E Main Ave				E Main Ave				Shaw Rd E				0				15-min Total	Rolling One Hour
	Eastbound				Westbound				Northbound				Southbound					
	UT	LT	TH	RT	UT	LT	TH	RT	UT	LT	TH	RT	UT	LT	TH	RT		
4:00 PM	0	0	5	1	0	3	4	0	0	4	0	3	0	0	0	0	20	0
4:15 PM	0	0	2	0	0	1	4	0	0	4	0	1	0	0	0	0	12	0
4:30 PM	0	0	2	2	0	4	2	0	0	2	0	1	0	0	0	0	13	0
4:45 PM	0	0	1	0	0	0	4	0	0	1	0	0	0	0	0	0	6	51
5:00 PM	0	0	2	1	0	5	2	0	0	0	0	1	0	0	0	0	11	42
5:15 PM	0	0	2	0	0	2	4	0	0	2	0	2	0	0	0	0	12	42
5:30 PM	0	0	2	0	0	2	3	0	0	0	0	6	0	0	0	0	13	42
5:45 PM	0	0	0	0	0	2	1	0	0	0	0	2	0	0	0	0	5	41
Count Total	0	0	16	4	0	19	24	0	0	13	0	16	0	0	0	0	92	0
Peak Hour	0	0	7	3	0	11	12	0	0	5	0	4	0	0	0	0	42	0

Two-Hour Count Summaries - Bikes

Interval Start	E Main Ave			E Main Ave			Shaw Rd E			0			15-min Total	Rolling One Hour
	Eastbound			Westbound			Northbound			Southbound				
	LT	TH	RT	LT	TH	RT	LT	TH	RT	LT	TH	RT		
4:00 PM	0	0	0	0	0	0	0	0	0	0	0	0	0	0
4:15 PM	0	0	0	0	0	0	0	0	0	0	0	0	0	0
4:30 PM	0	0	0	0	0	0	0	0	0	0	0	0	0	0
4:45 PM	0	0	0	0	0	0	0	0	0	0	0	0	0	0
5:00 PM	0	0	0	0	0	0	0	0	1	0	0	0	1	1
5:15 PM	0	0	0	0	0	0	0	0	0	0	0	0	0	1
5:30 PM	0	0	0	0	0	0	0	0	0	0	0	0	0	1
5:45 PM	0	0	0	0	0	0	0	0	0	0	0	0	0	1
Count Total	0	0	0	0	0	0	0	0	1	0	0	0	1	0
Peak Hour	0	0	0	0	0	0	0	0	1	0	0	0	1	0

Note: U-Turn volumes for bikes are included in Left-Turn, if any.

Shaw Rd E E Pioneer



Peak Hour

Date: 03/22/2022
Count Period: 4:00 PM to 6:00 PM
Peak Hour: 4:30 PM to 5:30 PM

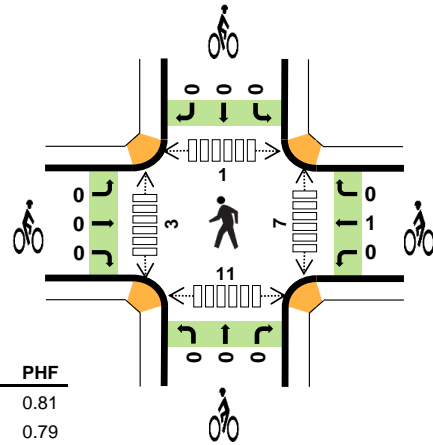
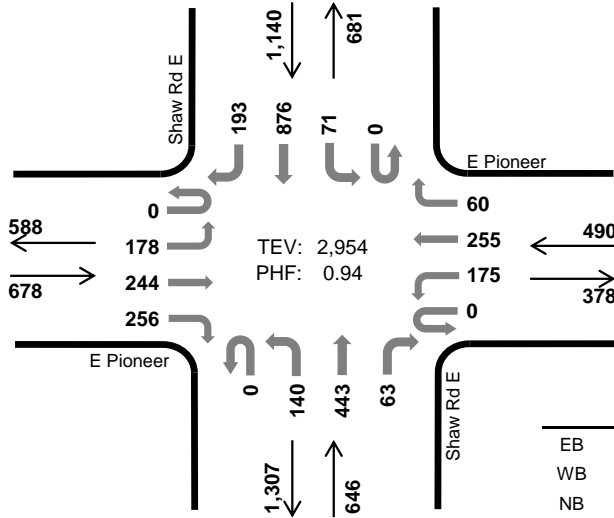

	HV %:	PHF
EB	0.9%	0.81
WB	1.8%	0.79
NB	1.7%	0.81
SB	1.1%	0.89
TOTAL	1.3%	0.94

Two-Hour Count Summaries

Interval Start	E Pioneer Eastbound				E Pioneer Westbound				Shaw Rd E Northbound				Shaw Rd E Southbound				15-min Total	Rolling One Hour	
	UT	LT	TH	RT	UT	LT	TH	RT	UT	LT	TH	RT	UT	LT	TH	RT			
4:00 PM	0	31	71	54	0	38	72	21	0	44	118	12	0	12	196	41	710	0	
4:15 PM	0	43	50	62	0	35	60	13	0	41	98	20	0	16	189	39	666	0	
4:30 PM	0	42	70	42	0	54	81	21	0	50	123	27	0	21	207	44	782	0	
4:45 PM	0	45	51	54	0	42	60	14	0	34	96	9	0	23	243	56	727	2,885	
5:00 PM	0	48	75	86	0	40	75	14	0	37	93	12	0	13	219	41	753	2,928	
5:15 PM	0	43	48	74	0	39	39	11	0	19	131	15	0	14	207	52	692	2,954	
5:30 PM	0	60	53	59	0	40	53	10	0	31	82	7	0	16	200	39	650	2,822	
5:45 PM	0	24	55	55	0	32	60	13	0	26	104	23	0	21	249	36	698	2,793	
Count Total	0	336	473	486	0	320	500	117	0	282	845	125	0	136	1,710	348	5,678	0	
Peak Hour	All	0	178	244	256	0	175	255	60	0	140	443	63	0	71	876	193	2,954	0
	HV	0	1	4	1	0	4	4	1	0	2	9	0	0	4	7	1	38	0
	HV%	-	1%	2%	0%	-	2%	2%	2%	-	1%	2%	0%	-	6%	1%	1%	1%	0

Note: Two-hour count summary volumes include heavy vehicles but exclude bicycles in overall count.

Interval Start	Heavy Vehicle Totals					Bicycles					Pedestrians (Crossing Leg)				
	EB	WB	NB	SB	Total	EB	WB	NB	SB	Total	East	West	North	South	Total
4:00 PM	6	6	4	2	18	0	0	0	0	0	0	0	0	0	0
4:15 PM	2	3	6	3	14	0	0	0	0	0	3	0	0	0	5
4:30 PM	2	3	2	5	12	0	0	0	0	0	6	2	0	10	18
4:45 PM	1	1	1	1	4	0	1	0	0	1	0	1	1	0	2
5:00 PM	2	3	4	3	12	0	0	0	0	0	0	0	0	0	0
5:15 PM	1	2	4	3	10	0	0	0	0	0	1	0	0	1	2
5:30 PM	0	2	5	1	8	0	0	0	0	0	1	0	0	3	4
5:45 PM	0	1	5	4	10	0	0	0	0	0	1	0	0	1	2
Count Total	14	21	31	22	88	0	1	0	0	1	12	3	1	20	36
Peak Hour	6	9	11	12	38	0	1	0	0	1	7	3	1	11	22

Two-Hour Count Summaries - Heavy Vehicles																		
Interval Start	E Pioneer				E Pioneer				Shaw Rd E				Shaw Rd E				15-min Total	Rolling One Hour
	Eastbound				Westbound				Northbound				Southbound					
	UT	LT	TH	RT	UT	LT	TH	RT	UT	LT	TH	RT	UT	LT	TH	RT		
4:00 PM	0	0	4	2	0	1	1	4	0	2	2	0	0	1	1	0	18	0
4:15 PM	0	0	2	0	0	2	1	0	0	1	5	0	0	0	3	0	14	0
4:30 PM	0	1	1	0	0	1	1	1	0	0	2	0	0	2	3	0	12	0
4:45 PM	0	0	0	1	0	1	0	0	0	0	1	0	0	0	0	1	4	48
5:00 PM	0	0	2	0	0	1	2	0	0	2	2	0	0	2	1	0	12	42
5:15 PM	0	0	1	0	0	1	1	0	0	0	4	0	0	0	3	0	10	38
5:30 PM	0	0	0	0	0	1	0	1	0	1	4	0	0	0	1	0	8	34
5:45 PM	0	0	0	0	0	0	1	0	0	1	2	2	0	0	4	0	10	40
Count Total	0	1	10	3	0	8	7	6	0	7	22	2	0	5	16	1	88	0
Peak Hour	0	1	4	1	0	4	4	1	0	2	9	0	0	4	7	1	38	0

Two-Hour Count Summaries - Bikes																		
Interval Start	E Pioneer			E Pioneer			Shaw Rd E			Shaw Rd E			15-min Total	Rolling One Hour				
	Eastbound			Westbound			Northbound			Southbound								
	LT	TH	RT	LT	TH	RT	LT	TH	RT	LT	TH	RT						
4:00 PM	0	0	0	0	0	0	0	0	0	0	0	0	0	0	0	0	0	0
4:15 PM	0	0	0	0	0	0	0	0	0	0	0	0	0	0	0	0	0	0
4:30 PM	0	0	0	0	0	0	0	0	0	0	0	0	0	0	0	0	0	0
4:45 PM	0	0	0	0	1	0	0	0	0	0	0	0	0	0	0	0	1	1
5:00 PM	0	0	0	0	0	0	0	0	0	0	0	0	0	0	0	0	0	1
5:15 PM	0	0	0	0	0	0	0	0	0	0	0	0	0	0	0	0	0	1
5:30 PM	0	0	0	0	0	0	0	0	0	0	0	0	0	0	0	0	0	1
5:45 PM	0	0	0	0	0	0	0	0	0	0	0	0	0	0	0	0	0	0
Count Total	0	0	0	0	1	0	0	0	0	0	0	0	0	0	0	0	1	0
Peak Hour	0	0	0	0	1	0	0	0	0	0	0	0	0	0	0	0	1	0

Note: U-Turn volumes for bikes are included in Left-Turn, if any.

E Main Ave SR 410 Ramps

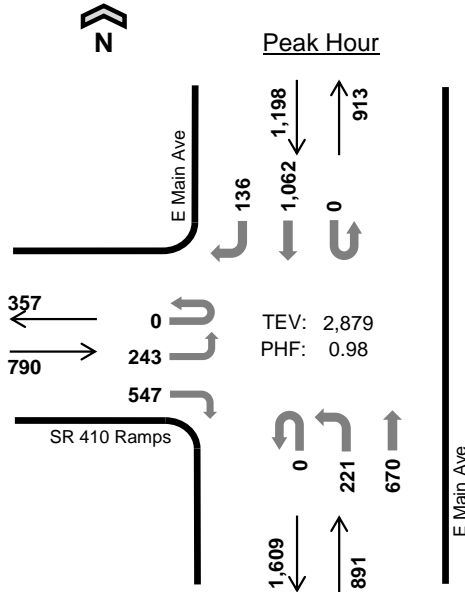

Date: 03/22/2022
Count Period: 4:00 PM to 6:00 PM
Peak Hour: 4:30 PM to 5:30 PM

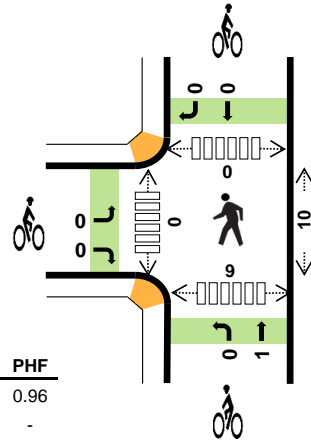

	HV %:	PHF
EB	5.8%	0.96
WB	-	-
NB	1.5%	0.93
SB	2.5%	0.90
TOTAL	3.1%	0.98

Two-Hour Count Summaries

Interval Start	SR 410 Ramps				0			E Main Ave				E Main Ave				15-min Total	Rolling One Hour		
	Eastbound				Westbound			Northbound				Southbound							
	UT	LT	TH	RT	UT	LT	TH	RT	UT	LT	TH	RT	UT	LT	TH	RT			
4:00 PM	0	57	0	102	0	0	0	0	0	60	165	0	0	0	252	28	664	0	
4:15 PM	0	64	0	99	0	0	0	0	0	37	146	0	0	0	259	38	643	0	
4:30 PM	0	62	0	141	0	0	0	0	0	60	179	0	0	0	227	34	703	0	
4:45 PM	0	59	0	137	0	0	0	0	0	44	150	0	0	0	294	37	721	2,731	
5:00 PM	0	59	0	146	0	0	0	0	0	66	165	0	0	0	271	27	734	2,801	
5:15 PM	0	63	0	123	0	0	0	0	0	51	176	0	0	0	270	38	721	2,879	
5:30 PM	0	46	0	112	0	0	0	0	0	44	139	0	0	0	256	40	637	2,813	
5:45 PM	0	68	0	105	0	0	0	0	0	33	145	0	0	0	182	28	561	2,653	
Count Total	0	478	0	965	0	0	0	0	0	395	1,265	0	0	0	2,011	270	5,384	0	
Peak Hour	All	0	243	0	547	0	0	0	0	0	221	670	0	0	0	1,062	136	2,879	0
	HV	0	34	0	12	0	0	0	0	0	3	10	0	0	0	23	7	89	0
	HV%	-	14%	-	2%	-	-	-	-	-	1%	1%	-	-	-	2%	5%	3%	0

Note: Two-hour count summary volumes include heavy vehicles but exclude bicycles in overall count.

Interval Start	Heavy Vehicle Totals					Bicycles					Pedestrians (Crossing Leg)				
	EB	WB	NB	SB	Total	EB	WB	NB	SB	Total	East	West	North	South	Total
4:00 PM	12	0	6	4	22	0	0	0	0	0	5	0	0	6	11
4:15 PM	18	0	4	8	30	0	0	0	0	0	4	0	0	3	7
4:30 PM	12	0	3	5	20	0	0	0	0	0	3	0	0	2	5
4:45 PM	10	0	1	6	17	0	0	0	0	0	3	0	0	3	6
5:00 PM	10	0	6	13	29	0	0	1	0	1	2	0	0	2	4
5:15 PM	14	0	3	6	23	0	0	0	0	0	2	0	0	2	4
5:30 PM	10	0	6	7	23	0	0	0	0	0	1	0	0	1	2
5:45 PM	6	0	5	2	13	0	0	0	0	0	3	0	0	2	5
Count Total	92	0	34	51	177	0	0	1	0	1	23	0	0	21	44
Peak Hr	46	0	13	30	89	0	0	1	0	1	10	0	0	9	19

Two-Hour Count Summaries - Heavy Vehicles														15-min Total	Rolling One Hour			
Interval Start	SR 410 Ramps				0				E Main Ave				E Main Ave					
	Eastbound				Westbound				Northbound				Southbound					
	UT	LT	TH	RT	UT	LT	TH	RT	UT	LT	TH	RT	UT	LT	TH	RT		
4:00 PM	0	8	0	4	0	0	0	0	0	1	5	0	0	0	3	1	22	0
4:15 PM	0	16	0	2	0	0	0	0	0	0	4	0	0	0	4	4	30	0
4:30 PM	0	9	0	3	0	0	0	0	0	0	3	0	0	0	3	2	20	0
4:45 PM	0	9	0	1	0	0	0	0	0	0	1	0	0	0	5	1	17	89
5:00 PM	0	6	0	4	0	0	0	0	0	2	4	0	0	0	11	2	29	96
5:15 PM	0	10	0	4	0	0	0	0	0	1	2	0	0	0	4	2	23	89
5:30 PM	0	8	0	2	0	0	0	0	0	2	4	0	0	0	6	1	23	92
5:45 PM	0	4	0	2	0	0	0	0	0	0	5	0	0	0	1	1	13	88
Count Total	0	70	0	22	0	0	0	0	0	6	28	0	0	0	37	14	177	0
Peak Hour	0	34	0	12	0	0	0	0	0	3	10	0	0	0	23	7	89	0

Two-Hour Count Summaries - Bikes														15-min Total	Rolling One Hour			
Interval Start	SR 410 Ramps			0			E Main Ave			E Main Ave								
	Eastbound			Westbound			Northbound			Southbound								
	LT	TH	RT	LT	TH	RT	LT	TH	RT	LT	TH	RT						
4:00 PM	0	0	0	0	0	0	0	0	0	0	0	0	0	0	0	0	0	0
4:15 PM	0	0	0	0	0	0	0	0	0	0	0	0	0	0	0	0	0	0
4:30 PM	0	0	0	0	0	0	0	0	0	0	0	0	0	0	0	0	0	0
4:45 PM	0	0	0	0	0	0	0	0	0	0	0	0	0	0	0	0	0	0
5:00 PM	0	0	0	0	0	0	0	1	0	0	0	0	0	0	0	0	1	1
5:15 PM	0	0	0	0	0	0	0	0	0	0	0	0	0	0	0	0	0	1
5:30 PM	0	0	0	0	0	0	0	0	0	0	0	0	0	0	0	0	0	1
5:45 PM	0	0	0	0	0	0	0	0	0	0	0	0	0	0	0	0	0	1
Count Total	0	0	0	0	0	0	0	1	0	0	0	0	0	0	0	0	1	0
Peak Hour	0	0	0	0	0	0	0	1	0	0	0	0	0	0	0	0	1	0

Note: U-Turn volumes for bikes are included in Left-Turn, if any.

E Main Ave SR 410 Ramps



Peak Hour

Date: 03/22/2022
Count Period: 4:00 PM to 6:00 PM
Peak Hour: 4:30 PM to 5:30 PM

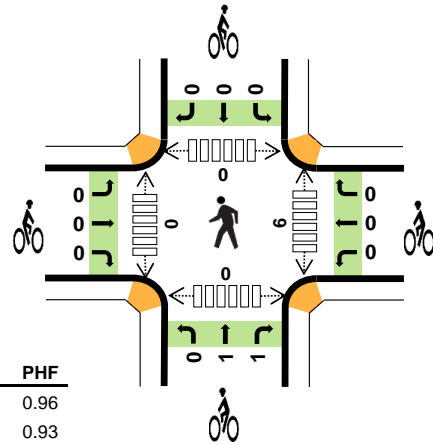
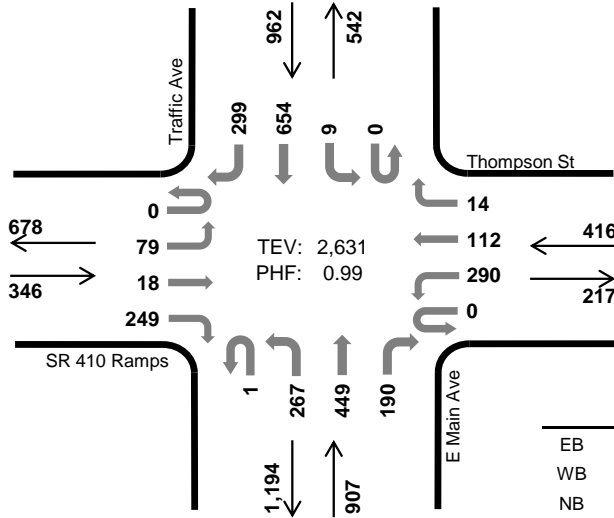

	HV %:	PHF
EB	2.0%	0.96
WB	3.1%	0.93
NB	5.5%	0.93
SB	5.2%	0.93
TOTAL	4.6%	0.99

Two-Hour Count Summaries

Interval Start	SR 410 Ramps				Thompson St				E Main Ave				Traffic Ave				15-min Total	Rolling One Hour	
	Eastbound		Westbound		Westbound		Northbound		Southbound		Southbound		Southbound						
	UT	LT	TH	RT	UT	LT	TH	RT	UT	LT	TH	RT	UT	LT	TH	RT			
4:00 PM	0	14	5	66	0	61	24	2	0	75	90	47	0	3	152	102	641	0	
4:15 PM	0	16	4	70	0	64	37	2	0	55	110	57	0	4	168	77	664	0	
4:30 PM	0	24	6	60	0	66	44	2	1	64	129	49	0	3	138	73	659	0	
4:45 PM	0	22	5	63	0	81	22	3	0	52	110	48	0	2	181	75	664	2,628	
5:00 PM	0	16	5	63	0	79	25	3	0	72	100	43	0	2	161	74	643	2,630	
5:15 PM	0	17	2	63	0	64	21	6	0	79	110	50	0	2	174	77	665	2,631	
5:30 PM	0	13	4	63	0	62	20	5	0	74	98	31	0	5	168	61	604	2,576	
5:45 PM	0	14	2	46	0	37	13	2	0	46	108	43	0	3	132	55	501	2,413	
Count Total	0	136	33	494	0	514	206	25	1	517	855	368	0	24	1,274	594	5,041	0	
Peak Hour	All	0	79	18	249	0	290	112	14	1	267	449	190	0	9	654	299	2,631	0
	HV	0	2	3	2	0	8	4	1	0	8	35	7	0	0	18	32	120	0
	HV%	-	3%	17%	1%	-	3%	4%	7%	0%	3%	8%	4%	-	0%	3%	11%	5%	0

Note: Two-hour count summary volumes include heavy vehicles but exclude bicycles in overall count.

Interval Start	Heavy Vehicle Totals					Bicycles					Pedestrians (Crossing Leg)				
	EB	WB	NB	SB	Total	EB	WB	NB	SB	Total	East	West	North	South	Total
4:00 PM	1	2	14	10	27	0	0	0	0	0	1	0	0	0	1
4:15 PM	3	14	16	17	50	0	0	0	0	0	3	0	0	0	3
4:30 PM	2	2	14	17	35	0	0	1	0	1	1	0	0	0	1
4:45 PM	1	4	9	18	32	0	0	0	0	0	1	0	0	0	1
5:00 PM	3	4	12	7	26	0	0	1	0	1	2	0	0	0	2
5:15 PM	1	3	15	8	27	0	0	0	0	0	2	0	0	0	2
5:30 PM	5	3	11	4	23	0	0	0	0	0	1	0	0	0	1
5:45 PM	1	1	6	8	16	0	0	0	0	0	3	0	0	0	3
Count Total	17	33	97	89	236	0	0	2	0	2	14	0	0	0	14
Peak Hour	7	13	50	50	120	0	0	2	0	2	6	0	0	0	6

Two-Hour Count Summaries - Heavy Vehicles																		
Interval Start	SR 410 Ramps				Thompson St				E Main Ave				Traffic Ave				15-min Total	Rolling One Hour
	Eastbound				Westbound				Northbound				Southbound					
	UT	LT	TH	RT	UT	LT	TH	RT	UT	LT	TH	RT	UT	LT	TH	RT		
4:00 PM	0	0	0	1	0	1	1	0	0	1	10	3	0	0	1	9	27	0
4:15 PM	0	0	1	2	0	2	12	0	0	2	11	3	0	0	6	11	50	0
4:30 PM	0	2	0	0	0	2	0	0	0	1	11	2	0	0	3	14	35	0
4:45 PM	0	0	1	0	0	2	1	1	0	1	7	1	0	0	4	14	32	144
5:00 PM	0	0	1	2	0	3	1	0	0	3	6	3	0	0	6	1	26	143
5:15 PM	0	0	1	0	0	1	2	0	0	3	11	1	0	0	5	3	27	120
5:30 PM	0	1	1	3	0	2	0	1	0	2	8	1	0	0	2	2	23	108
5:45 PM	0	1	0	0	0	0	1	0	0	1	4	1	0	0	2	6	16	92
Count Total	0	4	5	8	0	13	18	2	0	14	68	15	0	0	29	60	236	0
Peak Hour	0	2	3	2	0	8	4	1	0	8	35	7	0	0	18	32	120	0

Two-Hour Count Summaries - Bikes																		
Interval Start	SR 410 Ramps			Thompson St			E Main Ave			Traffic Ave			15-min Total	Rolling One Hour				
	Eastbound			Westbound			Northbound			Southbound								
	LT	TH	RT	LT	TH	RT	LT	TH	RT	LT	TH	RT						
4:00 PM	0	0	0	0	0	0	0	0	0	0	0	0	0	0	0	0	0	0
4:15 PM	0	0	0	0	0	0	0	0	0	0	0	0	0	0	0	0	0	0
4:30 PM	0	0	0	0	0	0	0	0	0	0	1	0	0	0	0	0	1	0
4:45 PM	0	0	0	0	0	0	0	0	0	0	0	0	0	0	0	0	0	1
5:00 PM	0	0	0	0	0	0	0	0	0	1	0	0	0	0	0	0	1	2
5:15 PM	0	0	0	0	0	0	0	0	0	0	0	0	0	0	0	0	0	2
5:30 PM	0	0	0	0	0	0	0	0	0	0	0	0	0	0	0	0	0	1
5:45 PM	0	0	0	0	0	0	0	0	0	0	0	0	0	0	0	0	0	1
Count Total	0	0	0	0	0	0	0	0	0	1	1	0	0	0	0	0	2	0
Peak Hour	0	0	0	0	0	0	0	0	0	1	1	0	0	0	0	0	2	0

Note: U-Turn volumes for bikes are included in Left-Turn, if any.

Appendix B

Level of Service (LOS) Calculations at Study Intersections

2022 Existing PM Peak Hour

Lanes, Volumes, Timings
1: 2nd St NE & E Main Ave

04/14/2022



Lane Group	EBL	EBT	EBR	WBL	WBT	WBR	NBL	NBT	NBR	SBL	SBT	SBR
Lane Configurations	↖	↗			↖	↗		↕				
Traffic Volume (vph)	35	271	0	0	280	227	88	621	0	0	0	0
Future Volume (vph)	35	271	0	0	280	227	88	621	0	0	0	0
Satd. Flow (prot)	1752	1810	0	0	1845	1538	0	3544	0	0	0	0
Flt Permitted	0.369							0.994				
Satd. Flow (perm)	675	1810	0	0	1845	1494	0	3541	0	0	0	0
Satd. Flow (RTOR)												
Confl. Peds. (#/hr)	14					14	3					
Peak Hour Factor	0.94	0.94	0.94	0.94	0.94	0.94	0.94	0.94	0.94	0.94	0.94	0.94
Heavy Vehicles (%)	3%	5%	0%	0%	3%	5%	3%	1%	0%	0%	0%	0%
Shared Lane Traffic (%)												
Lane Group Flow (vph)	37	288	0	0	298	241	0	755	0	0	0	0
Turn Type	pm+pt	NA			NA	Perm	Perm	NA				
Protected Phases	3	8			4			2				
Permitted Phases	8					4	2					
Detector Phase	3	8			4	4	2	2				
Switch Phase												
Minimum Initial (s)	5.0	5.0			5.0	5.0	10.0	10.0				
Minimum Split (s)	9.0	28.0			28.0	28.0	26.0	26.0				
Total Split (s)	10.0	45.0			29.0	29.0	53.0	53.0				
Total Split (%)	10.2%	45.9%			29.6%	29.6%	54.1%	54.1%				
Yellow Time (s)	3.0	3.0			3.0	3.0	3.0	3.0				
All-Red Time (s)	1.0	1.0			1.0	1.0	1.0	1.0				
Lost Time Adjust (s)	0.0	0.0			0.0	0.0		0.0				
Total Lost Time (s)	4.0	4.0			4.0	4.0		4.0				
Lead/Lag	Lead				Lag	Lag						
Lead-Lag Optimize?	Yes				Yes	Yes						
Recall Mode	None	None			None	None	None	None				
Act Effct Green (s)	14.2	14.2			11.7	11.7		15.2				
Actuated g/C Ratio	0.37	0.37			0.30	0.30		0.39				
v/c Ratio	0.09	0.43			0.54	0.53		0.54				
Control Delay	7.8	10.7			16.3	17.4		12.5				
Queue Delay	0.0	0.0			0.0	0.0		0.0				
Total Delay	7.8	10.7			16.3	17.4		12.5				
LOS	A	B			B	B		B				
Approach Delay		10.4			16.8			12.5				
Approach LOS		B			B			B				

Intersection Summary

Cycle Length: 98	
Actuated Cycle Length: 38.6	
Natural Cycle: 65	
Control Type: Actuated-Uncoordinated	
Maximum v/c Ratio: 0.54	
Intersection Signal Delay: 13.5	Intersection LOS: B
Intersection Capacity Utilization 51.0%	ICU Level of Service A
Analysis Period (min) 15	

Splits and Phases: 1: 2nd St NE & E Main Ave

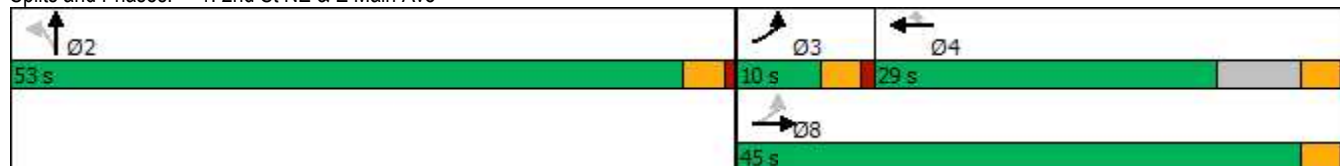

Lanes, Volumes, Timings
2: 5th St SE & E Main Ave

04/14/2022



Lane Group	EBL	EBT	EBR	WBL	WBT	WBR	NBL	NBT	NBR	SBL	SBT	SBR
Lane Configurations												
Traffic Volume (vph)	8	299	30	209	465	91	12	119	89	203	468	20
Future Volume (vph)	8	299	30	209	465	91	12	119	89	203	468	20
Ideal Flow (vphpl)	1900	1900	1900	1900	1900	1900	1900	1900	1900	1900	1900	1900
Storage Length (ft)	200		0	200		0	110		0	110		0
Storage Lanes	1		0	1		0	1		0	1		0
Taper Length (ft)	25			25			25			25		
Right Turn on Red			Yes			Yes			Yes			Yes
Link Speed (mph)		30			25			25			25	
Link Distance (ft)		343			822			178			685	
Travel Time (s)		7.8			22.4			4.9			18.7	
Confl. Peds. (#/hr)	1		2	2		1	5		2	2		5
Peak Hour Factor	0.98	0.98	0.98	0.98	0.98	0.98	0.98	0.98	0.98	0.98	0.98	0.98
Heavy Vehicles (%)	0%	5%	3%	2%	4%	1%	0%	3%	0%	4%	4%	10%
Shared Lane Traffic (%)												
Turn Type	Perm	NA		pm+pt	NA		Perm	NA		pm+pt	NA	
Protected Phases		6		5	2			4		3		8
Permitted Phases	6			2			4			8		
Detector Phase	6	6		5	2		4	4		3		8
Switch Phase												
Minimum Initial (s)	3.0	3.0		3.0	3.0		3.0	3.0		3.0		3.0
Minimum Split (s)	18.5	18.5		7.0	18.5		18.0	18.0		7.0		12.0
Total Split (s)	44.5	44.5		19.0	44.5		44.0	44.0		24.0		44.0
Total Split (%)	33.8%	33.8%		14.4%	33.8%		33.5%	33.5%		18.3%		33.5%
Yellow Time (s)	3.5	3.5		3.0	3.5		3.0	3.0		3.0		3.0
All-Red Time (s)	1.0	1.0		1.0	1.0		1.0	1.0		1.0		1.0
Lost Time Adjust (s)	0.0	0.0		0.0	0.0		0.0	0.0		0.0		0.0
Total Lost Time (s)	4.5	4.5		4.0	4.5		4.0	4.0		4.0		4.0
Lead/Lag	Lag	Lag		Lead			Lag	Lag		Lead		
Lead-Lag Optimize?	Yes	Yes		Yes			Yes	Yes		Yes		
Recall Mode	None	None		None	None		None	None		None		None

Intersection Summary

Area Type: Other

Cycle Length: 131.5

Actuated Cycle Length: 81.1

Natural Cycle: 55

Control Type: Actuated-Uncoordinated

Splits and Phases: 2: 5th St SE & E Main Ave

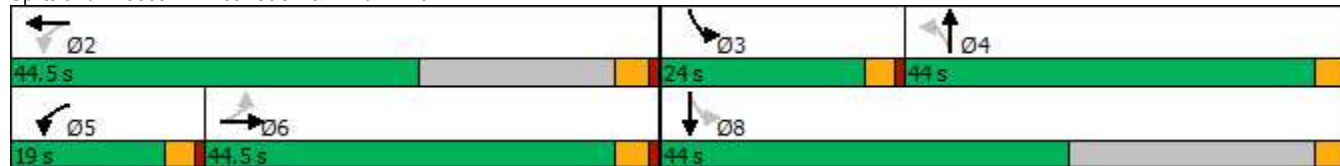

HCM 6th Signalized Intersection Summary

2: 5th St SE & E Main Ave

04/14/2022



Movement	EBL	EBT	EBR	WBL	WBT	WBR	NBL	NBT	NBR	SBL	SBT	SBR
Lane Configurations												
Traffic Volume (veh/h)	8	299	30	209	465	91	12	119	89	203	468	20
Future Volume (veh/h)	8	299	30	209	465	91	12	119	89	203	468	20
Initial Q (Qb), veh	0	0	0	0	0	0	0	0	0	0	0	0
Ped-Bike Adj(A_pbT)	1.00		1.00	1.00		1.00	0.99		0.99	0.99		0.99
Parking Bus, Adj	1.00	1.00	1.00	1.00	1.00	1.00	1.00	1.00	1.00	1.00	1.00	1.00
Work Zone On Approach		No			No			No			No	
Adj Sat Flow, veh/h/ln	1900	1826	1856	1870	1841	1885	1900	1856	1900	1841	1841	1752
Adj Flow Rate, veh/h	8	305	31	213	474	93	12	121	91	207	478	20
Peak Hour Factor	0.98	0.98	0.98	0.98	0.98	0.98	0.98	0.98	0.98	0.98	0.98	0.98
Percent Heavy Veh, %	0	5	3	2	4	1	0	3	0	4	4	10
Cap, veh/h	301	419	43	437	674	132	282	185	140	444	688	29
Arrive On Green	0.26	0.26	0.26	0.12	0.45	0.45	0.19	0.19	0.19	0.13	0.39	0.39
Sat Flow, veh/h	856	1630	166	1781	1494	293	909	977	735	1753	1754	73
Grp Volume(v), veh/h	8	0	336	213	0	567	12	0	212	207	0	498
Grp Sat Flow(s),veh/h/ln	856	0	1795	1781	0	1787	909	0	1712	1753	0	1827
Q Serve(g_s), s	0.4	0.0	9.3	4.3	0.0	13.8	0.6	0.0	6.2	4.7	0.0	12.4
Cycle Q Clear(g_c), s	3.7	0.0	9.3	4.3	0.0	13.8	2.0	0.0	6.2	4.7	0.0	12.4
Prop In Lane	1.00		0.09	1.00		0.16	1.00		0.43	1.00		0.04
Lane Grp Cap(c), veh/h	301	0	462	437	0	807	282	0	325	444	0	716
V/C Ratio(X)	0.03	0.00	0.73	0.49	0.00	0.70	0.04	0.00	0.65	0.47	0.00	0.70
Avail Cap(c_a), veh/h	711	0	1323	715	0	1317	779	0	1261	865	0	1346
HCM Platoon Ratio	1.00	1.00	1.00	1.00	1.00	1.00	1.00	1.00	1.00	1.00	1.00	1.00
Upstream Filter(l)	1.00	0.00	1.00	1.00	0.00	1.00	1.00	0.00	1.00	1.00	0.00	1.00
Uniform Delay (d), s/veh	17.7	0.0	18.4	12.0	0.0	12.0	19.2	0.0	20.3	13.6	0.0	13.8
Incr Delay (d2), s/veh	0.0	0.0	2.7	1.0	0.0	1.4	0.1	0.0	2.7	0.9	0.0	1.5
Initial Q Delay(d3),s/veh	0.0	0.0	0.0	0.0	0.0	0.0	0.0	0.0	0.0	0.0	0.0	0.0
%ile BackOfQ(50%),veh/ln	0.1	0.0	3.8	1.6	0.0	5.0	0.1	0.0	2.5	1.8	0.0	4.8
Unsig. Movement Delay, s/veh												
LnGrp Delay(d),s/veh	17.7	0.0	21.1	13.1	0.0	13.3	19.3	0.0	23.0	14.5	0.0	15.3
LnGrp LOS	B	A	C	B	A	B	B	A	C	B	A	B
Approach Vol, veh/h		344			780			224			705	
Approach Delay, s/veh		21.0			13.3			22.8			15.0	
Approach LOS		C			B			C			B	
Timer - Assigned Phs		2	3	4	5	6		8				
Phs Duration (G+Y+Rc), s		29.0	11.0	14.3	10.5	18.5		25.3				
Change Period (Y+Rc), s		4.5	4.0	4.0	4.0	4.5		4.0				
Max Green Setting (Gmax), s		40.0	20.0	40.0	15.0	40.0		40.0				
Max Q Clear Time (g_c+I1), s		15.8	6.7	8.2	6.3	11.3		14.4				
Green Ext Time (p_c), s		5.1	0.6	1.8	0.5	2.7		4.3				
Intersection Summary												
HCM 6th Ctrl Delay			16.2									
HCM 6th LOS			B									

Lanes, Volumes, Timings
3: SR 512 EB & E Pioneer Way

04/14/2022

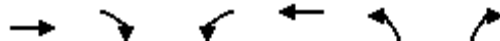

Lane Group	EBT	EBR	WBL	WBT	NBL	NBR
Lane Configurations	↑↑		↖	↑↑	↖	↗
Traffic Volume (vph)	371	126	26	788	84	292
Future Volume (vph)	371	126	26	788	84	292
Ideal Flow (vphpl)	1900	1900	1900	1900	1900	1900
Grade (%)	0%			0%	-3%	
Storage Length (ft)		0	250		0	200
Storage Lanes		0	1		1	1
Taper Length (ft)			25		25	
Right Turn on Red		Yes				Yes
Link Speed (mph)	35			35	35	
Link Distance (ft)	811			556	336	
Travel Time (s)	15.8			10.8	6.5	
Confl. Peds. (#/hr)		4				
Peak Hour Factor	0.90	0.90	0.90	0.90	0.90	0.90
Heavy Vehicles (%)	1%	2%	4%	2%	4%	5%
Shared Lane Traffic (%)						
Turn Type	NA		Prot	NA	Prot	Perm
Protected Phases	6		5	2	4	
Permitted Phases						4
Detector Phase	6		5	2	4	4
Switch Phase						
Minimum Initial (s)	10.0		5.0	10.0	10.0	10.0
Minimum Split (s)	39.3		12.3	17.3	17.3	17.3
Total Split (s)	67.3		32.3	67.3	32.3	32.3
Total Split (%)	51.0%		24.5%	51.0%	24.5%	24.5%
Yellow Time (s)	4.5		4.5	4.5	4.5	4.5
All-Red Time (s)	2.8		2.8	2.8	2.8	2.8
Lost Time Adjust (s)	0.0		0.0	0.0	0.0	0.0
Total Lost Time (s)	7.3		7.3	7.3	7.3	7.3
Lead/Lag	Lag		Lead			
Lead-Lag Optimize?	Yes		Yes			
Recall Mode	Min		None	Min	None	None

Intersection Summary

Area Type: Other

Cycle Length: 131.9

Actuated Cycle Length: 50.1

Natural Cycle: 70

Control Type: Actuated-Uncoordinated

Splits and Phases: 3: SR 512 EB & E Pioneer Way

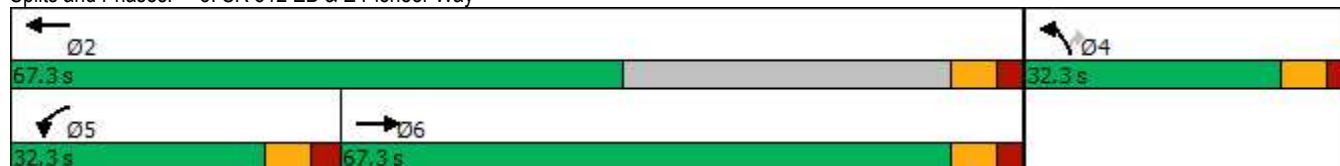

HCM 6th Signalized Intersection Summary
 3: SR 512 EB & E Pioneer Way

04/14/2022



Movement	EBT	EBR	WBL	WBT	NBL	NBR
Lane Configurations	↑↑		↖	↑↑	↖	↗
Traffic Volume (veh/h)	371	126	26	788	84	292
Future Volume (veh/h)	371	126	26	788	84	292
Initial Q (Qb), veh	0	0	0	0	0	0
Ped-Bike Adj(A_pbT)		0.99	1.00		1.00	1.00
Parking Bus, Adj	1.00	1.00	1.00		1.00	1.00
Work Zone On Approach	No			No	No	
Adj Sat Flow, veh/h/ln	1885	1870	1841	1870	1958	1943
Adj Flow Rate, veh/h	412	140	29	876	93	324
Peak Hour Factor	0.90	0.90	0.90	0.90	0.90	0.90
Percent Heavy Veh, %	1	2	4	2	4	5
Cap, veh/h	697	234	58	1591	474	418
Arrive On Green	0.27	0.27	0.03	0.45	0.25	0.25
Sat Flow, veh/h	2721	883	1753	3647	1865	1647
Grp Volume(v), veh/h	279	273	29	876	93	324
Grp Sat Flow(s),veh/h/ln	1791	1718	1753	1777	1865	1647
Q Serve(g_s), s	6.6	6.8	0.8	8.8	1.9	8.9
Cycle Q Clear(g_c), s	6.6	6.8	0.8	8.8	1.9	8.9
Prop In Lane		0.51	1.00		1.00	1.00
Lane Grp Cap(c), veh/h	475	456	58	1591	474	418
V/C Ratio(X)	0.59	0.60	0.50	0.55	0.20	0.77
Avail Cap(c_a), veh/h	2194	2106	895	4354	952	841
HCM Platoon Ratio	1.00	1.00	1.00	1.00	1.00	1.00
Upstream Filter(l)	1.00	1.00	1.00	1.00	1.00	1.00
Uniform Delay (d), s/veh	15.7	15.7	23.3	9.9	14.3	17.0
Incr Delay (d2), s/veh	1.2	1.3	6.4	0.3	0.2	3.7
Initial Q Delay(d3),s/veh	0.0	0.0	0.0	0.0	0.0	0.0
%ile BackOfQ(50%),veh/ln	2.4	2.4	0.4	2.6	0.7	8.1
Unsig. Movement Delay, s/veh						
LnGrp Delay(d),s/veh	16.8	17.0	29.7	10.2	14.6	20.7
LnGrp LOS	B	B	C	B	B	C
Approach Vol, veh/h	552			905	417	
Approach Delay, s/veh	16.9			10.8	19.3	
Approach LOS	B			B	B	
Timer - Assigned Phs		2		4	5	6
Phs Duration (G+Y+Rc), s		29.2		19.7	8.9	20.3
Change Period (Y+Rc), s		* 7.3		* 7.3	* 7.3	* 7.3
Max Green Setting (Gmax), s		* 60		* 25	* 25	* 60
Max Q Clear Time (g_c+I1), s		10.8		10.9	2.8	8.8
Green Ext Time (p_c), s		7.3		1.5	0.0	3.7
Intersection Summary						
HCM 6th Ctrl Delay			14.5			
HCM 6th LOS			B			
Notes						
* HCM 6th computational engine requires equal clearance times for the phases crossing the barrier.						

Lanes, Volumes, Timings
4: E Pioneer Way & 15th St SE

04/14/2022



Lane Group	EBL	EBT	WBT	WBR	SBL	SBR	Ø4
Lane Configurations							
Traffic Volume (vph)	200	463	504	89	187	352	
Future Volume (vph)	200	463	504	89	187	352	
Satd. Flow (prot)	1719	3539	3463	0	1787	1599	
Flt Permitted	0.950				0.950		
Satd. Flow (perm)	1719	3539	3463	0	1787	1599	
Satd. Flow (RTOR)			12				
Peak Hour Factor	0.90	0.90	0.90	0.90	0.90	0.90	
Heavy Vehicles (%)	5%	2%	2%	1%	1%	1%	
Shared Lane Traffic (%)							
Lane Group Flow (vph)	222	514	659	0	208	391	
Turn Type	Prot	NA	NA		Prot	custom	
Protected Phases	1	6	2		3	1 3 4	4
Permitted Phases							
Detector Phase	1	6	2		3	1 3 4	
Switch Phase							
Minimum Initial (s)	10.0	10.0	10.0		10.0		10.0
Minimum Split (s)	16.0	16.0	26.0		16.0		32.0
Total Split (s)	36.0	36.0	36.0		41.0		32.0
Total Split (%)	24.8%	24.8%	24.8%		28.3%		22%
Yellow Time (s)	4.0	4.0	4.0		4.0		4.0
All-Red Time (s)	2.0	2.0	2.0		2.0		2.0
Lost Time Adjust (s)	0.0	0.0	0.0		0.0		
Total Lost Time (s)	6.0	6.0	6.0		6.0		
Lead/Lag	Lead		Lag		Lead		Lag
Lead-Lag Optimize?	Yes		Yes		Yes		Yes
Recall Mode	None	Min	Min		None		None
Act Effct Green (s)	19.2	51.4	25.9		20.2		64.7
Actuated g/C Ratio	0.19	0.50	0.25		0.20		0.63
v/c Ratio	0.70	0.29	0.75		0.60		0.39
Control Delay	53.8	16.7	43.0		47.6		10.7
Queue Delay	0.0	0.0	0.0		0.0		0.0
Total Delay	53.8	16.7	43.0		47.6		10.7
LOS	D	B	D		D		B
Approach Delay		27.9	43.0		23.5		
Approach LOS		C	D		C		

Intersection Summary

Cycle Length: 145
 Actuated Cycle Length: 103.1
 Natural Cycle: 90
 Control Type: Actuated-Uncoordinated
 Maximum v/c Ratio: 0.75
 Intersection Signal Delay: 31.5
 Intersection Capacity Utilization 53.2%
 Analysis Period (min) 15
 Intersection LOS: C
 ICU Level of Service A

Splits and Phases: 4: E Pioneer Way & 15th St SE

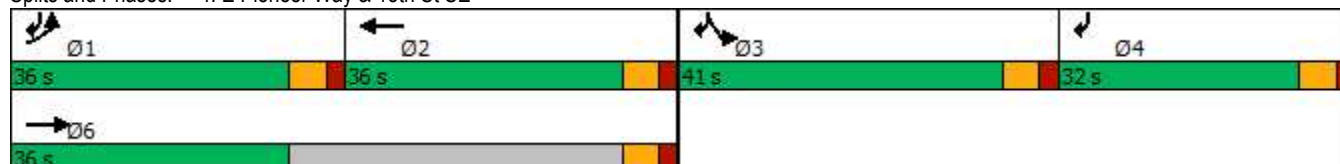

Lanes, Volumes, Timings
5: 15th St SE & E Main Ave

04/14/2022



Lane Group	EBL	EBT	EBR	WBL	WBT	WBR	NBL	NBT	NBR	SBL	SBT	SBR
Lane Configurations												
Traffic Volume (vph)	8	403	204	272	607	62	83	29	141	36	39	4
Future Volume (vph)	8	403	204	272	607	62	83	29	141	36	39	4
Ideal Flow (vphpl)	1900	1900	1900	1900	1900	1900	1900	1900	1900	1900	1900	1900
Storage Length (ft)	200		0	200		0	0		0	0		0
Storage Lanes	1		1	1		1	0		1	0		0
Taper Length (ft)	25			25			25			25		
Right Turn on Red			Yes			Yes			Yes			Yes
Link Speed (mph)		30			30			30			30	
Link Distance (ft)		1095			809			1163			142	
Travel Time (s)		24.9			18.4			26.4			3.2	
Confl. Peds. (#/hr)	5		1	1		8			4	3		
Peak Hour Factor	0.94	0.94	0.94	0.94	0.94	0.94	0.94	0.94	0.94	0.94	0.94	0.94
Heavy Vehicles (%)	0%	4%	0%	1%	3%	5%	5%	0%	4%	3%	0%	25%
Shared Lane Traffic (%)												
Turn Type	pm+pt	NA	Perm	pm+pt	NA	Free	Perm	NA	Free	Perm	NA	
Protected Phases	5	2		1	6			4			8	
Permitted Phases	2		2	6		Free	4		Free	8		
Detector Phase	5	2	2	1	6		4	4		8	8	
Switch Phase												
Minimum Initial (s)	3.0	3.0	3.0	3.0	3.0		3.0	3.0		3.0	3.0	
Minimum Split (s)	7.6	26.6	26.6	7.6	26.6		26.6	26.6		26.6	26.6	
Total Split (s)	24.6	34.6	34.6	26.6	34.6		24.6	24.6		24.6	24.6	
Total Split (%)	28.7%	40.3%	40.3%	31.0%	40.3%		28.7%	28.7%		28.7%	28.7%	
Yellow Time (s)	3.6	3.6	3.6	3.6	3.6		3.6	3.6		3.6	3.6	
All-Red Time (s)	1.0	1.0	1.0	1.0	1.0		1.0	1.0		1.0	1.0	
Lost Time Adjust (s)	0.0	0.0	0.0	0.0	0.0			0.0			0.0	
Total Lost Time (s)	4.6	4.6	4.6	4.6	4.6			4.6			4.6	
Lead/Lag	Lead	Lag	Lag	Lead	Lag							
Lead-Lag Optimize?	Yes	Yes	Yes	Yes	Yes							
Recall Mode	None	Min	Min	None	Min		None	None		None	None	

Intersection Summary

Area Type: Other

Cycle Length: 85.8

Actuated Cycle Length: 53.6

Natural Cycle: 65

Control Type: Actuated-Uncoordinated

Splits and Phases: 5: 15th St SE & E Main Ave

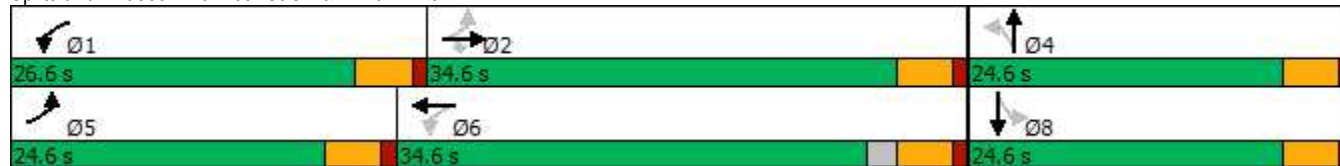

HCM 6th Signalized Intersection Summary
5: 15th St SE & E Main Ave

04/14/2022



Movement	EBL	EBT	EBR	WBL	WBT	WBR	NBL	NBT	NBR	SBL	SBT	SBR
Lane Configurations												
Traffic Volume (veh/h)	8	403	204	272	607	62	83	29	141	36	39	4
Future Volume (veh/h)	8	403	204	272	607	62	83	29	141	36	39	4
Initial Q (Qb), veh	0	0	0	0	0	0	0	0	0	0	0	0
Ped-Bike Adj(A_pbT)	1.00		0.99	1.00		1.00	0.99		1.00	0.99		0.99
Parking Bus, Adj	1.00	1.00	1.00	1.00	1.00	1.00	1.00	1.00	1.00	1.00	1.00	1.00
Work Zone On Approach		No			No			No			No	
Adj Sat Flow, veh/h/ln	1900	1841	1900	1885	1856	1826	1826	1900	1841	1856	1900	1530
Adj Flow Rate, veh/h	9	429	217	289	646	0	88	31	0	38	41	4
Peak Hour Factor	0.94	0.94	0.94	0.94	0.94	0.94	0.94	0.94	0.94	0.94	0.94	0.94
Percent Heavy Veh, %	0	4	0	1	3	5	5	0	4	3	0	25
Cap, veh/h	401	655	569	602	929		301	44		224	99	9
Arrive On Green	0.01	0.36	0.36	0.15	0.50	0.00	0.10	0.10	0.00	0.10	0.10	0.10
Sat Flow, veh/h	1810	1841	1599	1795	1856	1547	1197	422	1560	731	950	85
Grp Volume(v), veh/h	9	429	217	289	646	0	119	0	0	83	0	0
Grp Sat Flow(s),veh/h/ln	1810	1841	1599	1795	1856	1547	1618	0	1560	1767	0	0
Q Serve(g_s), s	0.1	7.0	3.6	3.0	9.5	0.0	0.9	0.0	0.0	0.0	0.0	0.0
Cycle Q Clear(g_c), s	0.1	7.0	3.6	3.0	9.5	0.0	2.4	0.0	0.0	1.5	0.0	0.0
Prop In Lane	1.00		1.00	1.00		1.00	0.74		1.00	0.46		0.05
Lane Grp Cap(c), veh/h	401	655	569	602	929		345	0		332	0	0
V/C Ratio(X)	0.02	0.66	0.38	0.48	0.70		0.35	0.00		0.25	0.00	0.00
Avail Cap(c_a), veh/h	1405	1552	1348	1438	1564		1022	0		1068	0	0
HCM Platoon Ratio	1.00	1.00	1.00	1.00	1.00	1.00	1.00	1.00	1.00	1.00	1.00	1.00
Upstream Filter(l)	1.00	1.00	1.00	1.00	1.00	0.00	1.00	0.00	0.00	1.00	0.00	0.00
Uniform Delay (d), s/veh	7.5	9.6	8.6	5.8	6.8	0.0	15.3	0.0	0.0	14.9	0.0	0.0
Incr Delay (d2), s/veh	0.0	1.1	0.4	0.6	0.9	0.0	0.6	0.0	0.0	0.4	0.0	0.0
Initial Q Delay(d3),s/veh	0.0	0.0	0.0	0.0	0.0	0.0	0.0	0.0	0.0	0.0	0.0	0.0
%ile BackOfQ(50%),veh/ln	0.0	2.2	0.9	0.6	2.3	0.0	0.8	0.0	0.0	0.6	0.0	0.0
Unsig. Movement Delay, s/veh												
LnGrp Delay(d),s/veh	7.6	10.8	9.0	6.4	7.8	0.0	15.9	0.0	0.0	15.3	0.0	0.0
LnGrp LOS	A	B	A	A	A		B	A		B	A	A
Approach Vol, veh/h		655			935	A		119	A			83
Approach Delay, s/veh		10.1			7.3			15.9				15.3
Approach LOS		B			A			B				B
Timer - Assigned Phs	1	2		4	5	6		8				
Phs Duration (G+Y+Rc), s	10.0	17.3		8.3	4.9	22.4		8.3				
Change Period (Y+Rc), s	4.6	4.6		4.6	4.6	4.6		4.6				
Max Green Setting (Gmax), s	22.0	30.0		20.0	20.0	30.0		20.0				
Max Q Clear Time (g_c+I1), s	5.0	9.0		4.4	2.1	11.5		3.5				
Green Ext Time (p_c), s	0.8	3.4		0.5	0.0	4.3		0.3				

Intersection Summary

HCM 6th Ctrl Delay	9.3
HCM 6th LOS	A

Notes

User approved pedestrian interval to be less than phase max green.
Unsignalized Delay for [NBR, WBR] is excluded from calculations of the approach delay and intersection delay.

Lanes, Volumes, Timings
 6: E Main Ave & Linden Lane Apt Homes

04/14/2022



Lane Group	EBL	EBT	WBT	WBR	SBL	SBR
Lane Configurations						
Traffic Volume (vph)	35	536	837	37	24	25
Future Volume (vph)	35	536	837	37	24	25
Ideal Flow (vphpl)	1900	1900	1900	1900	1900	1900
Storage Length (ft)	150			100	0	0
Storage Lanes	1			1	1	1
Taper Length (ft)	25				25	
Link Speed (mph)		35	25		25	
Link Distance (ft)		816	928		135	
Travel Time (s)		15.9	25.3		3.7	
Confl. Peds. (#/hr)	9			9		
Peak Hour Factor	0.95	0.95	0.95	0.95	0.95	0.95
Heavy Vehicles (%)	3%	2%	3%	5%	7%	8%
Shared Lane Traffic (%)						
Sign Control		Free	Free		Stop	

Intersection Summary

Area Type: Other
 Control Type: Unsignalized

HCM 6th TWSC
6: E Main Ave & Linden Lane Apt Homes

04/14/2022

Intersection						
Int Delay, s/veh	0.8					
Movement	EBL	EBT	WBT	WBR	SBL	SBR
Lane Configurations	↘	↑↑	↑↑	↘	↘	↘
Traffic Vol, veh/h	35	536	837	37	24	25
Future Vol, veh/h	35	536	837	37	24	25
Conflicting Peds, #/hr	9	0	0	9	0	0
Sign Control	Free	Free	Free	Free	Stop	Stop
RT Channelized	-	None	-	None	-	None
Storage Length	150	-	-	100	0	0
Veh in Median Storage, #	-	0	0	-	1	-
Grade, %	-	0	0	-	0	-
Peak Hour Factor	95	95	95	95	95	95
Heavy Vehicles, %	3	2	3	5	7	8
Mvmt Flow	37	564	881	39	25	26

Major/Minor	Major1	Major2	Minor2		
Conflicting Flow All	929	0	-	0	1246 450
Stage 1	-	-	-	-	890 -
Stage 2	-	-	-	-	356 -
Critical Hdwy	4.16	-	-	-	6.94 7.06
Critical Hdwy Stg 1	-	-	-	-	5.94 -
Critical Hdwy Stg 2	-	-	-	-	5.94 -
Follow-up Hdwy	2.23	-	-	-	3.57 3.38
Pot Cap-1 Maneuver	726	-	-	-	159 540
Stage 1	-	-	-	-	350 -
Stage 2	-	-	-	-	665 -
Platoon blocked, %	-	-	-	-	-
Mov Cap-1 Maneuver	720	-	-	-	148 535
Mov Cap-2 Maneuver	-	-	-	-	257 -
Stage 1	-	-	-	-	329 -
Stage 2	-	-	-	-	659 -

Approach	EB	WB	SB
HCM Control Delay, s	0.6	0	16.2
HCM LOS			C

Minor Lane/Major Mvmt	EBL	EBT	WBT	WBR	SBLn1	SBLn2
Capacity (veh/h)	720	-	-	-	257	535
HCM Lane V/C Ratio	0.051	-	-	-	0.098	0.049
HCM Control Delay (s)	10.3	-	-	-	20.5	12.1
HCM Lane LOS	B	-	-	-	C	B
HCM 95th %tile Q(veh)	0.2	-	-	-	0.3	0.2

Lanes, Volumes, Timings
7: Shaw Road E & E Main Ave

04/14/2022

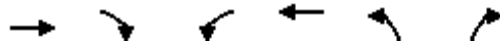

Lane Group	EBT	EBR	WBL	WBT	NBL	NBR	Ø4	Ø6
Lane Configurations	↑↑	↑	↑↑	↑	↑	↑↑		
Traffic Volume (vph)	366	202	1041	670	189	493		
Future Volume (vph)	366	202	1041	670	189	493		
Satd. Flow (prot)	3539	1583	3467	1863	1779	2856		
Flt Permitted			0.950		0.950			
Satd. Flow (perm)	3539	1583	3467	1863	1779	2856		
Satd. Flow (RTOR)		210				287		
Peak Hour Factor	0.96	0.96	0.96	0.96	0.96	0.96		
Heavy Vehicles (%)	2%	2%	1%	2%	3%	1%		
Shared Lane Traffic (%)								
Lane Group Flow (vph)	381	210	1084	698	197	514		
Turn Type	NA	Perm	Prot	NA	Prot	custom		
Protected Phases	2		1	1 2 6	3	3 4 1	4	6
Permitted Phases		2				3		
Detector Phase	2	2	1	1 2 6	3	3 4 1		
Switch Phase								
Minimum Initial (s)	7.0	7.0	7.0		7.0		7.0	7.0
Minimum Split (s)	33.0	33.0	12.0		12.0		22.5	33.0
Total Split (s)	39.0	39.0	42.0		24.0		24.0	39.0
Total Split (%)	30.2%	30.2%	32.6%		18.6%		19%	30%
Yellow Time (s)	4.0	4.0	4.0		4.0		3.5	4.0
All-Red Time (s)	1.0	1.0	1.0		1.0		1.0	1.0
Lost Time Adjust (s)	0.0	0.0	0.0		0.0			
Total Lost Time (s)	5.0	5.0	5.0		5.0			
Lead/Lag	Lag	Lag	Lead		Lead		Lag	
Lead-Lag Optimize?	Yes	Yes	Yes		Yes		Yes	
Recall Mode	None	None	None		None		None	None
Act Effct Green (s)	22.7	22.7	37.3	65.0	16.0	69.9		
Actuated g/C Ratio	0.22	0.22	0.36	0.63	0.16	0.68		
v/c Ratio	0.49	0.41	0.86	0.59	0.71	0.25		
Control Delay	37.0	7.0	40.2	13.8	57.1	3.4		
Queue Delay	0.0	0.0	0.0	0.0	0.0	0.0		
Total Delay	37.0	7.0	40.2	13.8	57.1	3.4		
LOS	D	A	D	B	E	A		
Approach Delay	26.3			29.8	18.3			
Approach LOS	C			C	B			

Intersection Summary

Cycle Length: 129

Actuated Cycle Length: 102.7

Natural Cycle: 110

Control Type: Actuated-Uncoordinated

Maximum v/c Ratio: 0.86

Intersection Signal Delay: 26.5

Intersection LOS: C

Intersection Capacity Utilization 62.8%

ICU Level of Service B

Analysis Period (min) 15

Splits and Phases: 7: Shaw Road E & E Main Ave

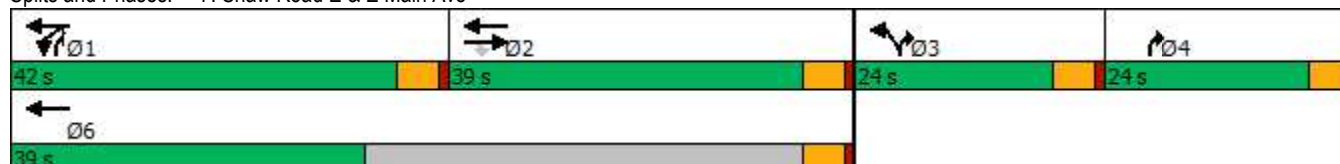

Lanes, Volumes, Timings
8: Shaw Road E & E Pioneer Way

04/14/2022



Lane Group	EBL	EBT	EBR	WBL	WBT	WBR	NBL	NBT	NBR	SBL	SBT	SBR
Lane Configurations												
Traffic Volume (vph)	178	244	256	175	255	60	140	443	63	71	876	193
Future Volume (vph)	178	244	256	175	255	60	140	443	63	71	876	193
Ideal Flow (vphpl)	1900	1900	1900	1900	1900	1900	1900	1900	1900	1900	1900	1900
Storage Length (ft)	150		0	180		0	250		0	400		0
Storage Lanes	1		1	1		0	2		0	1		0
Taper Length (ft)	25			25			25			25		
Right Turn on Red			Yes			Yes			Yes			No
Link Speed (mph)		35			35			35			35	
Link Distance (ft)		800			1013			763			634	
Travel Time (s)		15.6			19.7			14.9			12.4	
Confl. Peds. (#/hr)	1		11	11		1		7				3
Peak Hour Factor	0.94	0.94	0.94	0.94	0.94	0.94	0.94	0.94	0.94	0.94	0.94	0.94
Heavy Vehicles (%)	1%	2%	1%	2%	2%	2%	1%	2%	0%	6%	1%	1%
Shared Lane Traffic (%)												
Turn Type	pm+pt	NA	Perm	pm+pt	NA		Prot	NA		Prot	NA	
Protected Phases	7	4		3	8		5	2		1	6	
Permitted Phases	4		4	8								
Detector Phase	7	4	4	3	8		5	2		1	6	
Switch Phase												
Minimum Initial (s)	5.0	5.0	5.0	5.0	5.0		5.0	5.0		5.0	5.0	
Minimum Split (s)	11.5	43.5	43.5	11.5	53.5		11.5	36.5		11.5	39.5	
Total Split (s)	14.0	33.0	33.0	15.0	33.0		15.0	31.0		34.0	49.0	
Total Split (%)	12.4%	29.2%	29.2%	13.3%	29.2%		13.3%	27.4%		30.1%	43.4%	
Yellow Time (s)	4.5	4.5	4.5	4.5	4.5		4.5	4.5		4.5	4.5	
All-Red Time (s)	2.0	2.0	2.0	2.0	2.0		2.0	2.0		2.0	2.0	
Lost Time Adjust (s)	0.0	0.0	0.0	0.0	0.0		0.0	0.0		0.0	0.0	
Total Lost Time (s)	6.5	6.5	6.5	6.5	6.5		6.5	6.5		6.5	6.5	
Lead/Lag	Lead	Lag	Lag	Lead	Lag		Lead	Lag		Lead	Lag	
Lead-Lag Optimize?	Yes	Yes	Yes	Yes	Yes		Yes	Yes		Yes	Yes	
Recall Mode	None	None	None	None	None		None	None		None	None	

Intersection Summary

Area Type: Other

Cycle Length: 113

Actuated Cycle Length: 107.8

Natural Cycle: 120

Control Type: Actuated-Uncoordinated

Splits and Phases: 8: Shaw Road E & E Pioneer Way



HCM 6th Signalized Intersection Summary
8: Shaw Road E & E Pioneer Way

04/14/2022



Movement	EBL	EBT	EBR	WBL	WBT	WBR	NBL	NBT	NBR	SBL	SBT	SBR
Lane Configurations												
Traffic Volume (veh/h)	178	244	256	175	255	60	140	443	63	71	876	193
Future Volume (veh/h)	178	244	256	175	255	60	140	443	63	71	876	193
Initial Q (Qb), veh	0	0	0	0	0	0	0	0	0	0	0	0
Ped-Bike Adj(A_pbT)	0.99		0.98	0.99		0.99	1.00		0.99	1.00		1.00
Parking Bus, Adj	1.00	1.00	1.00	1.00	1.00	1.00	1.00	1.00	1.00	1.00	1.00	1.00
Work Zone On Approach		No			No			No			No	
Adj Sat Flow, veh/h/ln	1885	1870	1885	1870	1870	1870	1885	1870	1900	1811	1885	1885
Adj Flow Rate, veh/h	189	260	272	186	271	64	149	471	67	76	932	205
Peak Hour Factor	0.94	0.94	0.94	0.94	0.94	0.94	0.94	0.94	0.94	0.94	0.94	0.94
Percent Heavy Veh, %	1	2	1	2	2	2	1	2	0	6	1	1
Cap, veh/h	258	396	333	302	323	76	217	1180	167	99	1089	239
Arrive On Green	0.08	0.21	0.21	0.09	0.22	0.22	0.06	0.38	0.38	0.06	0.37	0.37
Sat Flow, veh/h	1795	1870	1573	1781	1458	344	3483	3121	442	1725	2918	641
Grp Volume(v), veh/h	189	260	272	186	0	335	149	267	271	76	572	565
Grp Sat Flow(s),veh/h/ln	1795	1870	1573	1781	0	1802	1742	1777	1786	1725	1791	1768
Q Serve(g_s), s	7.5	12.4	16.1	8.0	0.0	17.4	4.1	10.8	10.9	4.2	28.7	28.8
Cycle Q Clear(g_c), s	7.5	12.4	16.1	8.0	0.0	17.4	4.1	10.8	10.9	4.2	28.7	28.8
Prop In Lane	1.00		1.00	1.00		0.19	1.00		0.25	1.00		0.36
Lane Grp Cap(c), veh/h	258	396	333	302	0	400	217	672	675	99	668	660
V/C Ratio(X)	0.73	0.66	0.82	0.62	0.00	0.84	0.69	0.40	0.40	0.77	0.86	0.86
Avail Cap(c_a), veh/h	258	507	426	302	0	489	303	672	675	485	779	769
HCM Platoon Ratio	1.00	1.00	1.00	1.00	1.00	1.00	1.00	1.00	1.00	1.00	1.00	1.00
Upstream Filter(l)	1.00	1.00	1.00	1.00	0.00	1.00	1.00	1.00	1.00	1.00	1.00	1.00
Uniform Delay (d), s/veh	30.5	35.3	36.7	27.8	0.0	36.3	44.9	22.2	22.3	45.4	28.2	28.2
Incr Delay (d2), s/veh	10.3	2.0	9.4	3.7	0.0	10.3	3.8	0.4	0.4	11.9	8.3	8.5
Initial Q Delay(d3),s/veh	0.0	0.0	0.0	0.0	0.0	0.0	0.0	0.0	0.0	0.0	0.0	0.0
%ile BackOfQ(50%),veh/ln	4.2	5.7	6.9	3.6	0.0	8.6	1.9	4.4	4.5	2.1	13.2	13.1
Unsig. Movement Delay, s/veh												
LnGrp Delay(d),s/veh	40.8	37.3	46.1	31.6	0.0	46.7	48.7	22.6	22.7	57.3	36.5	36.7
LnGrp LOS	D	D	D	C	A	D	D	C	C	E	D	D
Approach Vol, veh/h		721			521			687			1213	
Approach Delay, s/veh		41.5			41.3			28.3			37.9	
Approach LOS		D			D			C			D	
Timer - Assigned Phs	1	2	3	4	5	6	7	8				
Phs Duration (G+Y+Rc), s	12.1	43.5	15.0	27.2	12.6	43.0	14.0	28.2				
Change Period (Y+Rc), s	6.5	6.5	6.5	6.5	6.5	6.5	6.5	6.5				
Max Green Setting (Gmax), s	27.5	24.5	8.5	26.5	8.5	42.5	7.5	26.5				
Max Q Clear Time (g_c+I1), s	6.2	12.9	10.0	18.1	6.1	30.8	9.5	19.4				
Green Ext Time (p_c), s	0.2	2.4	0.0	1.6	0.1	5.7	0.0	1.1				
Intersection Summary												
HCM 6th Ctrl Delay			37.2									
HCM 6th LOS			D									
Notes												
User approved pedestrian interval to be less than phase max green.												

Lanes, Volumes, Timings
 9: E Main Ave & SR 410 EB Ramps

04/14/2022



Lane Group	EBL	EBR	NBL	NBT	SBT	SBR	Ø4
Lane Configurations							
Traffic Volume (vph)	243	547	221	670	1062	136	
Future Volume (vph)	243	547	221	670	1062	136	
Satd. Flow (prot)	3035	1419	1787	3539	3467	0	
Flt Permitted	0.977		0.101				
Satd. Flow (perm)	3035	1419	190	3539	3467	0	
Satd. Flow (RTOR)	252	279			13		
Peak Hour Factor	0.98	0.98	0.98	0.98	0.98	0.98	
Heavy Vehicles (%)	14%	2%	1%	2%	2%	5%	
Shared Lane Traffic (%)		50%					
Lane Group Flow (vph)	527	279	226	684	1223	0	
Turn Type	Prot	Prot	pm+pt	NA	NA		
Protected Phases	8	8	1	6	2		4
Permitted Phases			6				
Detector Phase	8	8	1	6	2		
Switch Phase							
Minimum Initial (s)	6.0	6.0	6.0	6.0	6.0		6.0
Minimum Split (s)	10.5	10.5	10.5	10.5	10.5		22.0
Total Split (s)	23.0	23.0	15.0	45.0	30.0		32.0
Total Split (%)	23.0%	23.0%	15.0%	45.0%	30.0%		32%
Yellow Time (s)	3.5	3.5	3.5	3.5	3.5		2.0
All-Red Time (s)	1.0	1.0	1.0	1.0	1.0		0.0
Lost Time Adjust (s)	0.0	0.0	0.0	0.0	0.0		
Total Lost Time (s)	4.5	4.5	4.5	4.5	4.5		
Lead/Lag	Lead	Lead	Lead		Lag		Lag
Lead-Lag Optimize?	Yes	Yes	Yes		Yes		Yes
Recall Mode	None	None	None	C-Max	C-Max		Ped
Act Effct Green (s)	14.9	14.9	54.1	54.1	35.3		
Actuated g/C Ratio	0.15	0.15	0.54	0.54	0.35		
v/c Ratio	0.79	0.62	0.68	0.36	0.99		
Control Delay	30.0	11.2	30.0	14.3	48.3		
Queue Delay	0.0	0.0	0.0	0.0	0.0		
Total Delay	30.0	11.2	30.0	14.3	48.3		
LOS	C	B	C	B	D		
Approach Delay	23.5			18.2	48.3		
Approach LOS	C			B	D		

Intersection Summary

Cycle Length: 100
 Actuated Cycle Length: 100
 Offset: 0 (0%), Referenced to phase 2:SBT and 6:NBT, Start of Green
 Natural Cycle: 90
 Control Type: Actuated-Coordinated
 Maximum v/c Ratio: 0.99
 Intersection Signal Delay: 32.2
 Intersection LOS: C
 Intersection Capacity Utilization 69.9%
 ICU Level of Service C
 Analysis Period (min) 15

Splits and Phases: 9: E Main Ave & SR 410 EB Ramps

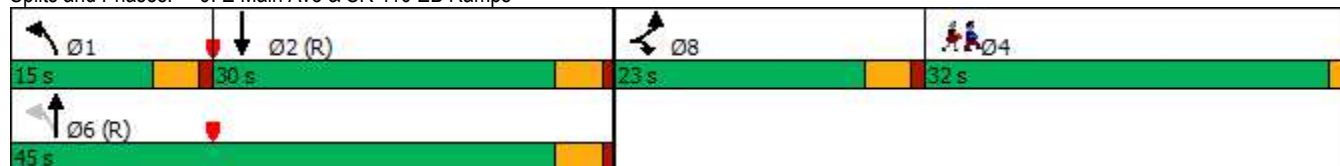

Lanes, Volumes, Timings
 10: E Main Ave & SR 410 WB Ramps/Thompson St

04/14/2022

Lane Group	EBL	EBT	EBR	WBL	WBT	WBR	NBL	NBT	NBR	SBL	SBT	SBR
Lane Configurations												
Traffic Volume (vph)	79	18	249	290	112	14	268	449	190	9	654	299
Future Volume (vph)	79	18	249	290	112	14	268	449	190	9	654	299
Ideal Flow (vphpl)	1900	1900	1900	1900	1900	1900	1900	1900	1900	1900	1900	1900
Grade (%)		0%			6%			-3%			-5%	
Storage Length (ft)	170		70	115		50	225		0	175		0
Storage Lanes	1		1	1		1	1		0	1		0
Taper Length (ft)	25			25			25			25		
Right Turn on Red			Yes			Yes			Yes			Yes
Link Speed (mph)		30			25			35			25	
Link Distance (ft)		499			309			676			392	
Travel Time (s)		11.3			8.4			13.2			10.7	
Confl. Peds. (#/hr)						6			6	6		
Peak Hour Factor	0.99	0.99	0.99	0.99	0.99	0.99	0.99	0.99	0.99	0.99	0.99	0.99
Heavy Vehicles (%)	3%	17%	1%	3%	4%	7%	3%	8%	4%	0%	3%	11%
Shared Lane Traffic (%)				32%								
Turn Type	Split	NA	Free	Split	NA	Free	pm+pt	NA		pm+pt	NA	
Protected Phases	8	8		4	4		1	6		5	2	
Permitted Phases			Free			Free	6			2		
Detector Phase	8	8		4	4		1	6		5	2	
Switch Phase												
Minimum Initial (s)	6.0	6.0		6.0	6.0		6.0	6.0		6.0	6.0	
Minimum Split (s)	10.5	10.5		10.5	10.5		10.5	28.5		10.5	10.5	
Total Split (s)	21.0	21.0		30.0	30.0		17.0	34.0		15.0	32.0	
Total Split (%)	21.0%	21.0%		30.0%	30.0%		17.0%	34.0%		15.0%	32.0%	
Yellow Time (s)	3.5	3.5		3.5	3.5		3.5	3.5		3.5	3.5	
All-Red Time (s)	1.0	1.0		1.0	1.0		1.0	1.0		1.0	1.0	
Lost Time Adjust (s)	0.0	0.0		0.0	0.0		0.0	0.0		0.0	0.0	
Total Lost Time (s)	4.5	4.5		4.5	4.5		4.5	4.5		4.5	4.5	
Lead/Lag	Lag	Lag		Lead	Lead		Lead	Lag		Lead	Lag	
Lead-Lag Optimize?	Yes	Yes		Yes	Yes		Yes	Yes		Yes	Yes	
Recall Mode	None	None		None	None		None	C-Max		None	C-Max	

Intersection Summary

Area Type: Other
 Cycle Length: 100
 Actuated Cycle Length: 100
 Offset: 61 (61%), Referenced to phase 2:SBTL and 6:NBTL, Start of Green
 Natural Cycle: 65
 Control Type: Actuated-Coordinated

Splits and Phases: 10: E Main Ave & SR 410 WB Ramps/Thompson St

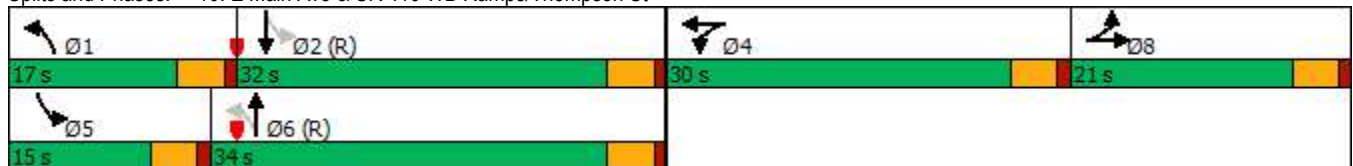

HCM 6th Signalized Intersection Summary
 10: E Main Ave & SR 410 WB Ramps/Thompson St

04/14/2022



Movement	EBL	EBT	EBR	WBL	WBT	WBR	NBL	NBT	NBR	SBL	SBT	SBR
Lane Configurations												
Traffic Volume (veh/h)	79	18	249	290	112	14	268	449	190	9	654	299
Future Volume (veh/h)	79	18	249	290	112	14	268	449	190	9	654	299
Initial Q (Qb), veh	0	0	0	0	0	0	0	0	0	0	0	0
Ped-Bike Adj(A_pbT)	1.00		1.00	1.00		1.00	1.00		0.99	1.00		0.99
Parking Bus, Adj	1.00		1.00	1.00		1.00	1.00		1.00	1.00		1.00
Work Zone On Approach		No			No			No			No	
Adj Sat Flow, veh/h/ln	1856	1648	1885	1644	1629	1584	1973	1898	1958	2097	2052	1932
Adj Flow Rate, veh/h	80	18	0	203	239	0	271	454	192	9	661	302
Peak Hour Factor	0.99	0.99	0.99	0.99	0.99	0.99	0.99	0.99	0.99	0.99	0.99	0.99
Percent Heavy Veh, %	3	17	1	3	4	7	3	8	4	0	3	11
Cap, veh/h	109	102		276	287		437	1406	590	512	1277	583
Arrive On Green	0.06	0.06	0.00	0.18	0.18	0.00	0.09	0.57	0.57	0.01	0.49	0.49
Sat Flow, veh/h	1767	1648	1598	1565	1629	1343	1879	2471	1036	1997	2594	1185
Grp Volume(v), veh/h	80	18	0	203	239	0	271	330	316	9	497	466
Grp Sat Flow(s),veh/h/ln	1767	1648	1598	1565	1629	1343	1879	1803	1705	1997	1949	1830
Q Serve(g_s), s	4.4	1.0	0.0	12.3	14.2	0.0	6.7	9.7	9.8	0.2	17.4	17.4
Cycle Q Clear(g_c), s	4.4	1.0	0.0	12.3	14.2	0.0	6.7	9.7	9.8	0.2	17.4	17.4
Prop In Lane	1.00		1.00	1.00		1.00	1.00		0.61	1.00		0.65
Lane Grp Cap(c), veh/h	109	102		276	287		437	1026	970	512	959	901
V/C Ratio(X)	0.73	0.18		0.74	0.83		0.62	0.32	0.33	0.02	0.52	0.52
Avail Cap(c_a), veh/h	292	272		399	415		503	1026	970	695	959	901
HCM Platoon Ratio	1.00	1.00	1.00	1.00	1.00	1.00	1.00	1.00	1.00	1.00	1.00	1.00
Upstream Filter(l)	1.00	1.00	0.00	1.00	1.00	0.00	0.82	0.82	0.82	1.00	1.00	1.00
Uniform Delay (d), s/veh	46.1	44.5	0.0	39.0	39.8	0.0	12.6	11.4	11.4	12.3	17.3	17.3
Incr Delay (d2), s/veh	9.1	0.8	0.0	4.0	9.3	0.0	1.5	0.7	0.7	0.0	2.0	2.1
Initial Q Delay(d3),s/veh	0.0	0.0	0.0	0.0	0.0	0.0	0.0	0.0	0.0	0.0	0.0	0.0
%ile BackOfQ(50%),veh/ln	2.2	0.4	0.0	5.0	6.4	0.0	2.7	3.8	3.6	0.1	8.1	7.7
Unsig. Movement Delay, s/veh												
LnGrp Delay(d),s/veh	55.2	45.3	0.0	43.0	49.1	0.0	14.1	12.1	12.1	12.3	19.3	19.4
LnGrp LOS	E	D		D	D		B	B	B	B	B	B
Approach Vol, veh/h		98	A		442	A		917			972	
Approach Delay, s/veh		53.4			46.3			12.7			19.3	
Approach LOS		D			D			B			B	
Timer - Assigned Phs	1	2		4	5	6		8				
Phs Duration (G+Y+Rc), s	13.5	53.7		22.1	5.8	61.4		10.7				
Change Period (Y+Rc), s	4.5	4.5		4.5	4.5	4.5		4.5				
Max Green Setting (Gmax), s	12.5	27.5		25.5	10.5	29.5		16.5				
Max Q Clear Time (g_c+I1), s	8.7	19.4		16.2	2.2	11.8		6.4				
Green Ext Time (p_c), s	0.3	4.0		1.4	0.0	3.7		0.2				

Intersection Summary

HCM 6th Ctrl Delay 23.1
 HCM 6th LOS C

Notes

User approved volume balancing among the lanes for turning movement.
 Unsignalized Delay for [EBR, WBR] is excluded from calculations of the approach delay and intersection delay.

2022 With Project PM Peak Hour

Lanes, Volumes, Timings
1: 2nd St NE & E Main Ave

04/14/2022



Lane Group	EBL	EBT	EBR	WBL	WBT	WBR	NBL	NBT	NBR	SBL	SBT	SBR
Lane Configurations	↖	↗			↖	↗		↕				
Traffic Volume (vph)	35	278	0	0	285	239	88	621	0	0	0	0
Future Volume (vph)	35	278	0	0	285	239	88	621	0	0	0	0
Satd. Flow (prot)	1752	1810	0	0	1845	1538	0	3544	0	0	0	0
Flt Permitted	0.365							0.994				
Satd. Flow (perm)	668	1810	0	0	1845	1494	0	3541	0	0	0	0
Satd. Flow (RTOR)												
Confl. Peds. (#/hr)	14					14	3					
Peak Hour Factor	0.94	0.94	0.94	0.94	0.94	0.94	0.94	0.94	0.94	0.94	0.94	0.94
Heavy Vehicles (%)	3%	5%	0%	0%	3%	5%	3%	1%	0%	0%	0%	0%
Shared Lane Traffic (%)												
Lane Group Flow (vph)	37	296	0	0	303	254	0	755	0	0	0	0
Turn Type	pm+pt	NA			NA	Perm	Perm	NA				
Protected Phases	3	8			4			2				
Permitted Phases	8					4	2					
Detector Phase	3	8			4	4	2	2				
Switch Phase												
Minimum Initial (s)	5.0	5.0			5.0	5.0	10.0	10.0				
Minimum Split (s)	9.0	28.0			28.0	28.0	26.0	26.0				
Total Split (s)	10.0	45.0			29.0	29.0	53.0	53.0				
Total Split (%)	10.2%	45.9%			29.6%	29.6%	54.1%	54.1%				
Yellow Time (s)	3.0	3.0			3.0	3.0	3.0	3.0				
All-Red Time (s)	1.0	1.0			1.0	1.0	1.0	1.0				
Lost Time Adjust (s)	0.0	0.0			0.0	0.0		0.0				
Total Lost Time (s)	4.0	4.0			4.0	4.0		4.0				
Lead/Lag	Lead				Lag	Lag						
Lead-Lag Optimize?	Yes				Yes	Yes						
Recall Mode	None	None			None	None	None	None				
Act Effct Green (s)	14.5	14.5			11.9	11.9		15.3				
Actuated g/C Ratio	0.37	0.37			0.31	0.31		0.39				
v/c Ratio	0.09	0.44			0.54	0.56		0.54				
Control Delay	7.8	10.8			16.3	17.9		12.7				
Queue Delay	0.0	0.0			0.0	0.0		0.0				
Total Delay	7.8	10.8			16.3	17.9		12.7				
LOS	A	B			B	B		B				
Approach Delay		10.5			17.0			12.7				
Approach LOS		B			B			B				

Intersection Summary

Cycle Length: 98	
Actuated Cycle Length: 38.9	
Natural Cycle: 65	
Control Type: Actuated-Uncoordinated	
Maximum v/c Ratio: 0.56	
Intersection Signal Delay: 13.7	Intersection LOS: B
Intersection Capacity Utilization 51.5%	ICU Level of Service A
Analysis Period (min) 15	

Splits and Phases: 1: 2nd St NE & E Main Ave

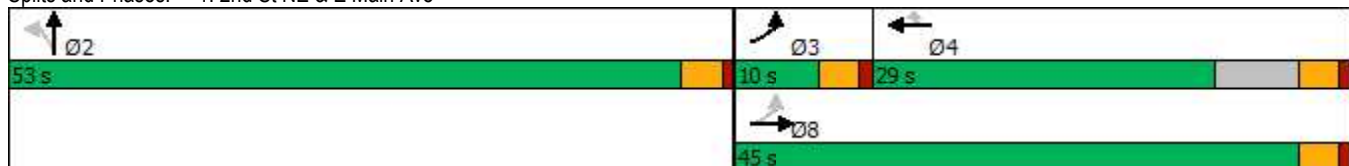

Lanes, Volumes, Timings
2: 5th St SE & E Main Ave

04/14/2022

Lane Group	EBL	EBT	EBR	WBL	WBT	WBR	NBL	NBT	NBR	SBL	SBT	SBR
Lane Configurations												
Traffic Volume (vph)	8	306	30	214	482	96	12	119	91	205	468	20
Future Volume (vph)	8	306	30	214	482	96	12	119	91	205	468	20
Ideal Flow (vphpl)	1900	1900	1900	1900	1900	1900	1900	1900	1900	1900	1900	1900
Storage Length (ft)	200		0	200		0	110		0	110		0
Storage Lanes	1		0	1		0	1		0	1		0
Taper Length (ft)	25			25			25			25		
Right Turn on Red			Yes			Yes			Yes			Yes
Link Speed (mph)		30			25			25			25	
Link Distance (ft)		343			822			178			685	
Travel Time (s)		7.8			22.4			4.9			18.7	
Confl. Peds. (#/hr)	1		2	2		1	5		2	2		5
Peak Hour Factor	0.98	0.98	0.98	0.98	0.98	0.98	0.98	0.98	0.98	0.98	0.98	0.98
Heavy Vehicles (%)	0%	5%	3%	2%	4%	1%	0%	3%	0%	4%	4%	10%
Shared Lane Traffic (%)												
Turn Type	Perm	NA		pm+pt	NA		Perm	NA		pm+pt	NA	
Protected Phases		6		5	2			4		3	8	
Permitted Phases	6			2			4			8		
Detector Phase	6	6		5	2		4	4		3	8	
Switch Phase												
Minimum Initial (s)	3.0	3.0		3.0	3.0		3.0	3.0		3.0	3.0	
Minimum Split (s)	18.5	18.5		7.0	18.5		18.0	18.0		7.0	12.0	
Total Split (s)	44.5	44.5		19.0	44.5		44.0	44.0		24.0	44.0	
Total Split (%)	33.8%	33.8%		14.4%	33.8%		33.5%	33.5%		18.3%	33.5%	
Yellow Time (s)	3.5	3.5		3.0	3.5		3.0	3.0		3.0	3.0	
All-Red Time (s)	1.0	1.0		1.0	1.0		1.0	1.0		1.0	1.0	
Lost Time Adjust (s)	0.0	0.0		0.0	0.0		0.0	0.0		0.0	0.0	
Total Lost Time (s)	4.5	4.5		4.0	4.5		4.0	4.0		4.0	4.0	
Lead/Lag	Lag	Lag		Lead			Lag	Lag		Lead		
Lead-Lag Optimize?	Yes	Yes		Yes			Yes	Yes		Yes		
Recall Mode	None	None		None	None		None	None		None	None	

Intersection Summary

Area Type: Other

Cycle Length: 131.5

Actuated Cycle Length: 82.1

Natural Cycle: 55

Control Type: Actuated-Uncoordinated

Splits and Phases: 2: 5th St SE & E Main Ave

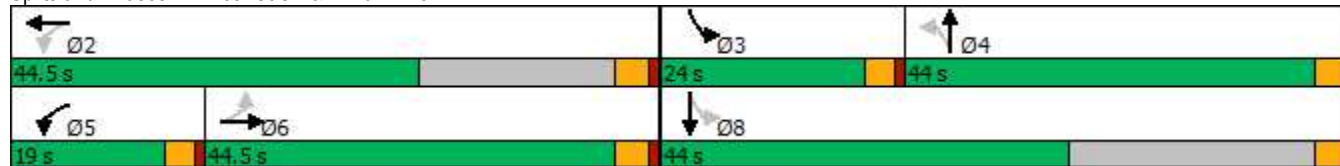

HCM 6th Signalized Intersection Summary
2: 5th St SE & E Main Ave

04/14/2022



Movement	EBL	EBT	EBR	WBL	WBT	WBR	NBL	NBT	NBR	SBL	SBT	SBR
Lane Configurations												
Traffic Volume (veh/h)	8	306	30	214	482	96	12	119	91	205	468	20
Future Volume (veh/h)	8	306	30	214	482	96	12	119	91	205	468	20
Initial Q (Qb), veh	0	0	0	0	0	0	0	0	0	0	0	0
Ped-Bike Adj(A_pbT)	1.00		1.00	1.00		1.00	0.99		0.99	0.99		0.99
Parking Bus, Adj	1.00	1.00	1.00	1.00	1.00	1.00	1.00	1.00	1.00	1.00	1.00	1.00
Work Zone On Approach		No			No			No			No	
Adj Sat Flow, veh/h/ln	1900	1826	1856	1870	1841	1885	1900	1856	1900	1841	1841	1752
Adj Flow Rate, veh/h	8	312	31	218	492	98	12	121	93	209	478	20
Peak Hour Factor	0.98	0.98	0.98	0.98	0.98	0.98	0.98	0.98	0.98	0.98	0.98	0.98
Percent Heavy Veh, %	0	5	3	2	4	1	0	3	0	4	4	10
Cap, veh/h	286	425	42	436	677	135	279	184	141	441	687	29
Arrive On Green	0.26	0.26	0.26	0.12	0.45	0.45	0.19	0.19	0.19	0.13	0.39	0.39
Sat Flow, veh/h	838	1634	162	1781	1490	297	909	967	743	1753	1754	73
Grp Volume(v), veh/h	8	0	343	218	0	590	12	0	214	209	0	498
Grp Sat Flow(s),veh/h/ln	838	0	1796	1781	0	1787	909	0	1710	1753	0	1827
Q Serve(g_s), s	0.4	0.0	9.7	4.5	0.0	14.9	0.6	0.0	6.4	4.8	0.0	12.6
Cycle Q Clear(g_c), s	4.6	0.0	9.7	4.5	0.0	14.9	2.1	0.0	6.4	4.8	0.0	12.6
Prop In Lane	1.00		0.09	1.00		0.17	1.00		0.43	1.00		0.04
Lane Grp Cap(c), veh/h	286	0	468	436	0	812	279	0	325	441	0	715
V/C Ratio(X)	0.03	0.00	0.73	0.50	0.00	0.73	0.04	0.00	0.66	0.47	0.00	0.70
Avail Cap(c_a), veh/h	674	0	1300	703	0	1293	764	0	1237	849	0	1322
HCM Platoon Ratio	1.00	1.00	1.00	1.00	1.00	1.00	1.00	1.00	1.00	1.00	1.00	1.00
Upstream Filter(l)	1.00	0.00	1.00	1.00	0.00	1.00	1.00	0.00	1.00	1.00	0.00	1.00
Uniform Delay (d), s/veh	18.5	0.0	18.7	12.2	0.0	12.3	19.6	0.0	20.7	13.8	0.0	14.1
Incr Delay (d2), s/veh	0.0	0.0	2.7	1.1	0.0	1.5	0.1	0.0	2.7	1.0	0.0	1.5
Initial Q Delay(d3),s/veh	0.0	0.0	0.0	0.0	0.0	0.0	0.0	0.0	0.0	0.0	0.0	0.0
%ile BackOfQ(50%),veh/ln	0.1	0.0	3.9	1.7	0.0	5.4	0.1	0.0	2.6	1.8	0.0	4.9
Unsig. Movement Delay, s/veh												
LnGrp Delay(d),s/veh	18.5	0.0	21.4	13.3	0.0	13.8	19.7	0.0	23.5	14.8	0.0	15.6
LnGrp LOS	B	A	C	B	A	B	B	A	C	B	A	B
Approach Vol, veh/h		351			808			226			707	
Approach Delay, s/veh		21.3			13.6			23.3			15.3	
Approach LOS		C			B			C			B	
Timer - Assigned Phs		2	3	4	5	6		8				
Phs Duration (G+Y+Rc), s		29.6	11.1	14.5	10.7	18.9		25.6				
Change Period (Y+Rc), s		4.5	4.0	4.0	4.0	4.5		4.0				
Max Green Setting (Gmax), s		40.0	20.0	40.0	15.0	40.0		40.0				
Max Q Clear Time (g_c+I1), s		16.9	6.8	8.4	6.5	11.7		14.6				
Green Ext Time (p_c), s		5.3	0.6	1.8	0.5	2.7		4.3				
Intersection Summary												
HCM 6th Ctrl Delay			16.5									
HCM 6th LOS			B									

Lanes, Volumes, Timings
3: SR 512 EB & E Pioneer Way

04/14/2022

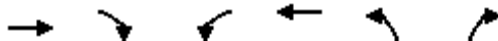

Lane Group	EBT	EBR	WBL	WBT	NBL	NBR
Lane Configurations	↑↑		↖	↑↑	↖	↗
Traffic Volume (vph)	371	126	26	798	84	297
Future Volume (vph)	371	126	26	798	84	297
Ideal Flow (vphpl)	1900	1900	1900	1900	1900	1900
Grade (%)	0%			0%	-3%	
Storage Length (ft)		0	250		0	200
Storage Lanes		0	1		1	1
Taper Length (ft)			25		25	
Right Turn on Red		Yes				Yes
Link Speed (mph)	35			35	35	
Link Distance (ft)	811			556	336	
Travel Time (s)	15.8			10.8	6.5	
Confl. Peds. (#/hr)		4				
Peak Hour Factor	0.90	0.90	0.90	0.90	0.90	0.90
Heavy Vehicles (%)	1%	2%	4%	2%	4%	4%
Shared Lane Traffic (%)						
Turn Type	NA		Prot	NA	Prot	Perm
Protected Phases	6		5	2	4	
Permitted Phases						4
Detector Phase	6		5	2	4	4
Switch Phase						
Minimum Initial (s)	10.0		5.0	10.0	10.0	10.0
Minimum Split (s)	39.3		12.3	17.3	17.3	17.3
Total Split (s)	67.3		32.3	67.3	32.3	32.3
Total Split (%)	51.0%		24.5%	51.0%	24.5%	24.5%
Yellow Time (s)	4.5		4.5	4.5	4.5	4.5
All-Red Time (s)	2.8		2.8	2.8	2.8	2.8
Lost Time Adjust (s)	0.0		0.0	0.0	0.0	0.0
Total Lost Time (s)	7.3		7.3	7.3	7.3	7.3
Lead/Lag	Lag		Lead			
Lead-Lag Optimize?	Yes		Yes			
Recall Mode	Min		None	Min	None	None

Intersection Summary

Area Type: Other

Cycle Length: 131.9

Actuated Cycle Length: 50.3

Natural Cycle: 70

Control Type: Actuated-Uncoordinated

Splits and Phases: 3: SR 512 EB & E Pioneer Way

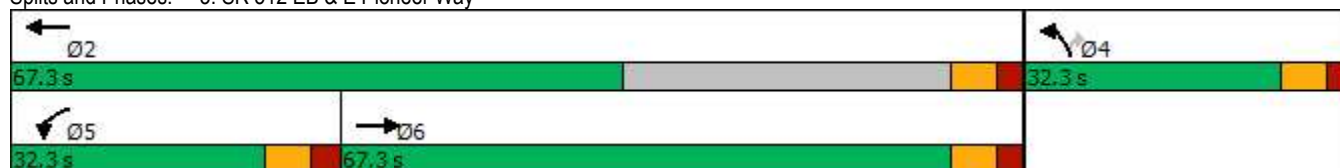

HCM 6th Signalized Intersection Summary
 3: SR 512 EB & E Pioneer Way

04/14/2022

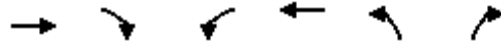

Movement	EBT	EBR	WBL	WBT	NBL	NBR
Lane Configurations	↑↑		↖	↑↑	↖	↗
Traffic Volume (veh/h)	371	126	26	798	84	297
Future Volume (veh/h)	371	126	26	798	84	297
Initial Q (Qb), veh	0	0	0	0	0	0
Ped-Bike Adj(A_pbT)		0.99	1.00		1.00	1.00
Parking Bus, Adj	1.00	1.00	1.00		1.00	1.00
Work Zone On Approach	No			No	No	
Adj Sat Flow, veh/h/ln	1885	1870	1841	1870	1958	1958
Adj Flow Rate, veh/h	412	140	29	887	93	330
Peak Hour Factor	0.90	0.90	0.90	0.90	0.90	0.90
Percent Heavy Veh, %	1	2	4	2	4	4
Cap, veh/h	696	234	58	1588	478	425
Arrive On Green	0.27	0.27	0.03	0.45	0.26	0.26
Sat Flow, veh/h	2721	883	1753	3647	1865	1659
Grp Volume(v), veh/h	279	273	29	887	93	330
Grp Sat Flow(s),veh/h/ln	1791	1718	1753	1777	1865	1659
Q Serve(g_s), s	6.7	6.8	0.8	9.0	1.9	9.1
Cycle Q Clear(g_c), s	6.7	6.8	0.8	9.0	1.9	9.1
Prop In Lane		0.51	1.00		1.00	1.00
Lane Grp Cap(c), veh/h	475	455	58	1588	478	425
V/C Ratio(X)	0.59	0.60	0.50	0.56	0.19	0.78
Avail Cap(c_a), veh/h	2186	2098	892	4338	948	844
HCM Platoon Ratio	1.00	1.00	1.00	1.00	1.00	1.00
Upstream Filter(l)	1.00	1.00	1.00	1.00	1.00	1.00
Uniform Delay (d), s/veh	15.7	15.8	23.4	10.0	14.3	17.0
Incr Delay (d2), s/veh	1.2	1.3	6.4	0.3	0.2	3.7
Initial Q Delay(d3),s/veh	0.0	0.0	0.0	0.0	0.0	0.0
%ile BackOfQ(50%),veh/ln	2.5	2.4	0.4	2.7	0.7	8.3
Unsig. Movement Delay, s/veh						
LnGrp Delay(d),s/veh	16.9	17.0	29.8	10.3	14.5	20.7
LnGrp LOS	B	B	C	B	B	C
Approach Vol, veh/h	552			916	423	
Approach Delay, s/veh	17.0			10.9	19.3	
Approach LOS	B			B	B	
Timer - Assigned Phs		2		4	5	6
Phs Duration (G+Y+Rc), s		29.3		19.9	8.9	20.3
Change Period (Y+Rc), s		* 7.3		* 7.3	* 7.3	* 7.3
Max Green Setting (Gmax), s		* 60		* 25	* 25	* 60
Max Q Clear Time (g_c+I1), s		11.0		11.1	2.8	8.8
Green Ext Time (p_c), s		7.5		1.6	0.0	3.7
Intersection Summary						
HCM 6th Ctrl Delay			14.6			
HCM 6th LOS			B			
Notes						
* HCM 6th computational engine requires equal clearance times for the phases crossing the barrier.						

Lanes, Volumes, Timings
4: E Pioneer Way & 15th St SE

04/14/2022



Lane Group	EBL	EBT	WBT	WBR	SBL	SBR	Ø4
Lane Configurations							
Traffic Volume (vph)	205	463	504	89	187	362	
Future Volume (vph)	205	463	504	89	187	362	
Satd. Flow (prot)	1719	3539	3463	0	1787	1599	
Flt Permitted	0.950				0.950		
Satd. Flow (perm)	1719	3539	3463	0	1787	1599	
Satd. Flow (RTOR)			12				
Peak Hour Factor	0.90	0.90	0.90	0.90	0.90	0.90	
Heavy Vehicles (%)	5%	2%	2%	1%	1%	1%	
Shared Lane Traffic (%)							
Lane Group Flow (vph)	228	514	659	0	208	402	
Turn Type	Prot	NA	NA		Prot	custom	
Protected Phases	1	6	2		3	1 3 4	4
Permitted Phases							
Detector Phase	1	6	2		3	1 3 4	
Switch Phase							
Minimum Initial (s)	10.0	10.0	10.0		10.0		10.0
Minimum Split (s)	16.0	16.0	26.0		16.0		32.0
Total Split (s)	36.0	36.0	36.0		41.0		32.0
Total Split (%)	24.8%	24.8%	24.8%		28.3%		22%
Yellow Time (s)	4.0	4.0	4.0		4.0		4.0
All-Red Time (s)	2.0	2.0	2.0		2.0		2.0
Lost Time Adjust (s)	0.0	0.0	0.0		0.0		
Total Lost Time (s)	6.0	6.0	6.0		6.0		
Lead/Lag	Lead		Lag		Lead		Lag
Lead-Lag Optimize?	Yes		Yes		Yes		Yes
Recall Mode	None	Min	Min		None		None
Act Effct Green (s)	19.6	51.8	25.9		20.5		65.5
Actuated g/C Ratio	0.19	0.50	0.25		0.20		0.63
v/c Ratio	0.70	0.29	0.75		0.59		0.40
Control Delay	54.2	16.7	43.6		47.5		10.7
Queue Delay	0.0	0.0	0.0		0.0		0.0
Total Delay	54.2	16.7	43.6		47.5		10.7
LOS	D	B	D		D		B
Approach Delay		28.2	43.6		23.3		
Approach LOS		C	D		C		

Intersection Summary

Cycle Length: 145
 Actuated Cycle Length: 103.9
 Natural Cycle: 90
 Control Type: Actuated-Uncoordinated
 Maximum v/c Ratio: 0.75
 Intersection Signal Delay: 31.8
 Intersection Capacity Utilization 53.5%
 Analysis Period (min) 15
 Intersection LOS: C
 ICU Level of Service A

Splits and Phases: 4: E Pioneer Way & 15th St SE

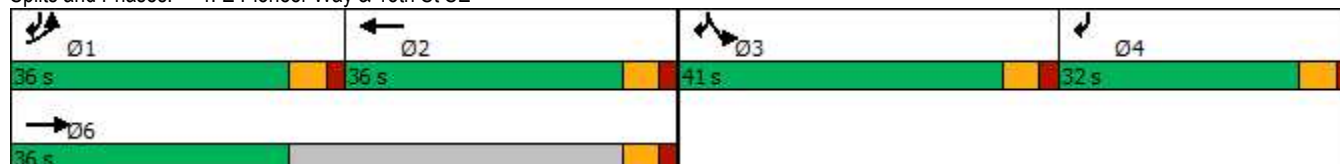

Lanes, Volumes, Timings
5: 15th St SE & E Main Ave

04/14/2022



Lane Group	EBL	EBT	EBR	WBL	WBT	WBR	NBL	NBT	NBR	SBL	SBT	SBR
Lane Configurations												
Traffic Volume (vph)	8	414	204	282	634	62	83	29	146	36	39	4
Future Volume (vph)	8	414	204	282	634	62	83	29	146	36	39	4
Ideal Flow (vphpl)	1900	1900	1900	1900	1900	1900	1900	1900	1900	1900	1900	1900
Storage Length (ft)	200		0	200		0	0		0	0		0
Storage Lanes	1		1	1		1	0		1	0		0
Taper Length (ft)	25			25			25			25		
Right Turn on Red			Yes			Yes			Yes			Yes
Link Speed (mph)		30			30			30				30
Link Distance (ft)		1095			809			1163				142
Travel Time (s)		24.9			18.4			26.4				3.2
Confl. Peds. (#/hr)	5		1	1		8			4	3		
Peak Hour Factor	0.94	0.94	0.94	0.94	0.94	0.94	0.94	0.94	0.94	0.94	0.94	0.94
Heavy Vehicles (%)	0%	4%	0%	1%	3%	5%	5%	0%	4%	3%	0%	25%
Shared Lane Traffic (%)												
Turn Type	pm+pt	NA	Perm	pm+pt	NA	Free	Perm	NA	Free	Perm	NA	
Protected Phases	5	2		1	6			4			8	
Permitted Phases	2		2	6		Free	4		Free	8		
Detector Phase	5	2	2	1	6		4	4		8	8	
Switch Phase												
Minimum Initial (s)	3.0	3.0	3.0	3.0	3.0		3.0	3.0		3.0	3.0	
Minimum Split (s)	7.6	26.6	26.6	7.6	26.6		26.6	26.6		26.6	26.6	
Total Split (s)	24.6	34.6	34.6	26.6	34.6		24.6	24.6		24.6	24.6	
Total Split (%)	28.7%	40.3%	40.3%	31.0%	40.3%		28.7%	28.7%		28.7%	28.7%	
Yellow Time (s)	3.6	3.6	3.6	3.6	3.6		3.6	3.6		3.6	3.6	
All-Red Time (s)	1.0	1.0	1.0	1.0	1.0		1.0	1.0		1.0	1.0	
Lost Time Adjust (s)	0.0	0.0	0.0	0.0	0.0			0.0			0.0	
Total Lost Time (s)	4.6	4.6	4.6	4.6	4.6			4.6			4.6	
Lead/Lag	Lead	Lag	Lag	Lead	Lag							
Lead-Lag Optimize?	Yes	Yes	Yes	Yes	Yes							
Recall Mode	None	Min	Min	None	Min		None	None		None	None	

Intersection Summary

Area Type: Other

Cycle Length: 85.8

Actuated Cycle Length: 54.3

Natural Cycle: 65

Control Type: Actuated-Uncoordinated

Splits and Phases: 5: 15th St SE & E Main Ave

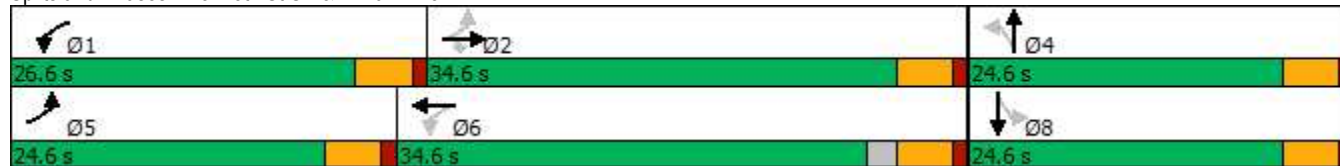

HCM 6th Signalized Intersection Summary
 5: 15th St SE & E Main Ave

04/14/2022



Movement	EBL	EBT	EBR	WBL	WBT	WBR	NBL	NBT	NBR	SBL	SBT	SBR
Lane Configurations												
Traffic Volume (veh/h)	8	414	204	282	634	62	83	29	146	36	39	4
Future Volume (veh/h)	8	414	204	282	634	62	83	29	146	36	39	4
Initial Q (Qb), veh	0	0	0	0	0	0	0	0	0	0	0	0
Ped-Bike Adj(A_pbT)	1.00		0.99	1.00		1.00	0.99		1.00	0.99		0.99
Parking Bus, Adj	1.00		1.00	1.00		1.00	1.00		1.00	1.00		1.00
Work Zone On Approach		No			No			No			No	
Adj Sat Flow, veh/h/ln	1900	1841	1900	1885	1856	1826	1826	1900	1841	1856	1900	1530
Adj Flow Rate, veh/h	9	440	217	300	674	0	88	31	0	38	41	4
Peak Hour Factor	0.94	0.94	0.94	0.94	0.94	0.94	0.94	0.94	0.94	0.94	0.94	0.94
Percent Heavy Veh, %	0	4	0	1	3	5	5	0	4	3	0	25
Cap, veh/h	388	662	575	602	943		297	44		220	100	9
Arrive On Green	0.01	0.36	0.36	0.16	0.51	0.00	0.10	0.10	0.00	0.10	0.10	0.10
Sat Flow, veh/h	1810	1841	1599	1795	1856	1547	1197	422	1560	726	956	85
Grp Volume(v), veh/h	9	440	217	300	674	0	119	0	0	83	0	0
Grp Sat Flow(s),veh/h/ln	1810	1841	1599	1795	1856	1547	1618	0	1560	1767	0	0
Q Serve(g_s), s	0.1	7.3	3.6	3.1	10.2	0.0	0.9	0.0	0.0	0.0	0.0	0.0
Cycle Q Clear(g_c), s	0.1	7.3	3.6	3.1	10.2	0.0	2.5	0.0	0.0	1.5	0.0	0.0
Prop In Lane	1.00		1.00	1.00		1.00	0.74		1.00	0.46		0.05
Lane Grp Cap(c), veh/h	388	662	575	602	943		341	0		329	0	0
V/C Ratio(X)	0.02	0.66	0.38	0.50	0.71		0.35	0.00		0.25	0.00	0.00
Avail Cap(c_a), veh/h	1372	1522	1322	1411	1534		1003	0		1048	0	0
HCM Platoon Ratio	1.00	1.00	1.00	1.00	1.00	1.00	1.00	1.00	1.00	1.00	1.00	1.00
Upstream Filter(l)	1.00	1.00	1.00	1.00	1.00	0.00	1.00	0.00	0.00	1.00	0.00	0.00
Uniform Delay (d), s/veh	7.6	9.8	8.6	6.0	6.9	0.0	15.6	0.0	0.0	15.2	0.0	0.0
Incr Delay (d2), s/veh	0.0	1.2	0.4	0.6	1.0	0.0	0.6	0.0	0.0	0.4	0.0	0.0
Initial Q Delay(d3),s/veh	0.0	0.0	0.0	0.0	0.0	0.0	0.0	0.0	0.0	0.0	0.0	0.0
%ile BackOfQ(50%),veh/ln	0.0	2.3	1.0	0.6	2.5	0.0	0.8	0.0	0.0	0.6	0.0	0.0
Unsig. Movement Delay, s/veh												
LnGrp Delay(d),s/veh	7.7	10.9	9.0	6.6	7.9	0.0	16.2	0.0	0.0	15.6	0.0	0.0
LnGrp LOS	A	B	A	A	A		B	A		B	A	A
Approach Vol, veh/h		666			974	A		119	A			83
Approach Delay, s/veh		10.3			7.5			16.2				15.6
Approach LOS		B			A			B				B
Timer - Assigned Phs	1	2		4	5	6		8				
Phs Duration (G+Y+Rc), s	10.2	17.7		8.4	4.9	23.0		8.4				
Change Period (Y+Rc), s	4.6	4.6		4.6	4.6	4.6		4.6				
Max Green Setting (Gmax), s	22.0	30.0		20.0	20.0	30.0		20.0				
Max Q Clear Time (g_c+I1), s	5.1	9.3		4.5	2.1	12.2		3.5				
Green Ext Time (p_c), s	0.8	3.5		0.5	0.0	4.5		0.3				

Intersection Summary

HCM 6th Ctrl Delay	9.4
HCM 6th LOS	A

Notes

User approved pedestrian interval to be less than phase max green.
 Unsignalized Delay for [NBR, WBR] is excluded from calculations of the approach delay and intersection delay.

Lanes, Volumes, Timings
 6: Site Access/Linden Lane Apt Homes & E Main Ave

04/14/2022



Lane Group	EBL	EBT	EBR	WBL	WBT	WBR	NBL	NBT	NBR	SBL	SBT	SBR
Lane Configurations												
Traffic Volume (vph)	35	536	16	32	837	37	37	0	71	24	0	25
Future Volume (vph)	35	536	16	32	837	37	37	0	71	24	0	25
Ideal Flow (vphpl)	1900	1900	1900	1900	1900	1900	1900	1900	1900	1900	1900	1900
Storage Length (ft)	150		0	150		100	0		0	0		0
Storage Lanes	1		0	1		1	0		0	1		1
Taper Length (ft)	25			25			25			25		
Link Speed (mph)		35			35			25				25
Link Distance (ft)		816			928			163				135
Travel Time (s)		15.9			18.1			4.4				3.7
Confl. Peds. (#/hr)	9						9					
Peak Hour Factor	0.95	0.95	0.95	0.95	0.95	0.95	0.95	0.95	0.95	0.95	0.95	0.95
Heavy Vehicles (%)	3%	2%	0%	6%	3%	5%	3%	0%	4%	8%	0%	8%
Shared Lane Traffic (%)												
Sign Control		Free			Free			Stop				Stop

Intersection Summary

Area Type: Other

Control Type: Unsignalized

HCM 6th TWSC
6: Site Access/Linden Lane Apt Homes & E Main Ave

04/14/2022

Intersection												
Int Delay, s/veh	2											
Movement	EBL	EBT	EBR	WBL	WBT	WBR	NBL	NBT	NBR	SBL	SBT	SBR
Lane Configurations	↖	↗		↖	↗	↖		↔		↖		↖
Traffic Vol, veh/h	35	536	16	32	837	37	37	0	71	24	0	25
Future Vol, veh/h	35	536	16	32	837	37	37	0	71	24	0	25
Conflicting Peds, #/hr	9	0	0	0	0	9	0	0	0	0	0	0
Sign Control	Free	Free	Free	Free	Free	Free	Stop	Stop	Stop	Stop	Stop	Stop
RT Channelized	-	-	None	-	-	None	-	-	None	-	-	None
Storage Length	150	-	-	150	-	100	-	-	-	0	-	0
Veh in Median Storage, #	-	0	-	-	0	-	-	1	-	-	1	-
Grade, %	-	0	-	-	0	-	-	0	-	-	0	-
Peak Hour Factor	95	95	95	95	95	95	95	95	95	95	95	95
Heavy Vehicles, %	3	2	0	6	3	5	3	0	4	8	0	8
Mvmt Flow	37	564	17	34	881	39	39	0	75	25	0	26

Major/Minor	Major1			Major2			Minor1			Minor2		
Conflicting Flow All	929	0	0	581	0	0	1156	1644	291	1314	-	450
Stage 1	-	-	-	-	-	-	647	647	-	958	-	-
Stage 2	-	-	-	-	-	-	509	997	-	356	-	-
Critical Hdwy	4.16	-	-	4.22	-	-	7.56	6.5	6.98	7.66	-	7.06
Critical Hdwy Stg 1	-	-	-	-	-	-	6.56	5.5	-	6.66	-	-
Critical Hdwy Stg 2	-	-	-	-	-	-	6.56	5.5	-	6.66	-	-
Follow-up Hdwy	2.23	-	-	2.26	-	-	3.53	4	3.34	3.58	-	3.38
Pot Cap-1 Maneuver	726	-	-	962	-	-	150	101	700	110	0	540
Stage 1	-	-	-	-	-	-	424	470	-	265	0	-
Stage 2	-	-	-	-	-	-	512	325	-	618	0	-
Platoon blocked, %	-	-	-	-	-	-	-	-	-	-	-	-
Mov Cap-1 Maneuver	720	-	-	962	-	-	133	92	700	91	-	535
Mov Cap-2 Maneuver	-	-	-	-	-	-	251	194	-	186	-	-
Stage 1	-	-	-	-	-	-	402	446	-	249	-	-
Stage 2	-	-	-	-	-	-	470	311	-	524	-	-

Approach	EB			WB			NB			SB		
HCM Control Delay, s	0.6			0.3			16.2			19.6		
HCM LOS							C			C		

Minor Lane/Major Mvmt	NBLn1	EBL	EBT	EBR	WBL	WBT	WBR	SBLn1	SBLn2
Capacity (veh/h)	434	720	-	-	962	-	-	186	535
HCM Lane V/C Ratio	0.262	0.051	-	-	0.035	-	-	0.136	0.049
HCM Control Delay (s)	16.2	10.3	-	-	8.9	-	-	27.4	12.1
HCM Lane LOS		C	B	-	A	-	-	D	B
HCM 95th %tile Q(veh)		1	0.2	-	0.1	-	-	0.5	0.2

Lanes, Volumes, Timings
7: Shaw Road E & E Main Ave

04/14/2022

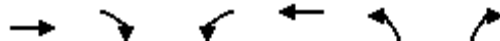

Lane Group	EBT	EBR	WBL	WBT	NBL	NBR	Ø4	Ø6
Lane Configurations	↑↑	↑	↑↑	↑	↑	↑↑		
Traffic Volume (vph)	417	222	1041	693	198	493		
Future Volume (vph)	417	222	1041	693	198	493		
Satd. Flow (prot)	3539	1599	3467	1863	1779	2856		
Flt Permitted			0.950		0.950			
Satd. Flow (perm)	3539	1599	3467	1863	1779	2856		
Satd. Flow (RTOR)		231				218		
Peak Hour Factor	0.96	0.96	0.96	0.96	0.96	0.96		
Heavy Vehicles (%)	2%	1%	1%	2%	3%	1%		
Shared Lane Traffic (%)								
Lane Group Flow (vph)	434	231	1084	722	206	514		
Turn Type	NA	Perm	Prot	NA	Prot	custom		
Protected Phases	2		1	1 2 6	3	3 4 1	4	6
Permitted Phases		2				3		
Detector Phase	2	2	1	1 2 6	3	3 4 1		
Switch Phase								
Minimum Initial (s)	7.0	7.0	7.0		7.0		7.0	7.0
Minimum Split (s)	33.0	33.0	12.0		12.0		22.5	33.0
Total Split (s)	39.0	39.0	42.0		24.0		24.0	39.0
Total Split (%)	30.2%	30.2%	32.6%		18.6%		19%	30%
Yellow Time (s)	4.0	4.0	4.0		4.0		3.5	4.0
All-Red Time (s)	1.0	1.0	1.0		1.0		1.0	1.0
Lost Time Adjust (s)	0.0	0.0	0.0		0.0			
Total Lost Time (s)	5.0	5.0	5.0		5.0			
Lead/Lag	Lag	Lag	Lead		Lead		Lag	
Lead-Lag Optimize?	Yes	Yes	Yes		Yes		Yes	
Recall Mode	None	None	None		None		None	None
Act Effct Green (s)	24.9	24.9	37.3	67.2	16.6	70.5		
Actuated g/C Ratio	0.24	0.24	0.35	0.64	0.16	0.67		
v/c Ratio	0.52	0.42	0.88	0.61	0.74	0.26		
Control Delay	37.2	6.6	43.6	14.2	60.0	4.7		
Queue Delay	0.0	0.0	0.0	0.0	0.0	0.0		
Total Delay	37.2	6.6	43.6	14.2	60.0	4.7		
LOS	D	A	D	B	E	A		
Approach Delay	26.6			31.8	20.5			
Approach LOS	C			C	C			

Intersection Summary

Cycle Length: 129

Actuated Cycle Length: 105.5

Natural Cycle: 110

Control Type: Actuated-Uncoordinated

Maximum v/c Ratio: 0.88

Intersection Signal Delay: 28.2

Intersection LOS: C

Intersection Capacity Utilization 64.7%

ICU Level of Service C

Analysis Period (min) 15

Splits and Phases: 7: Shaw Road E & E Main Ave

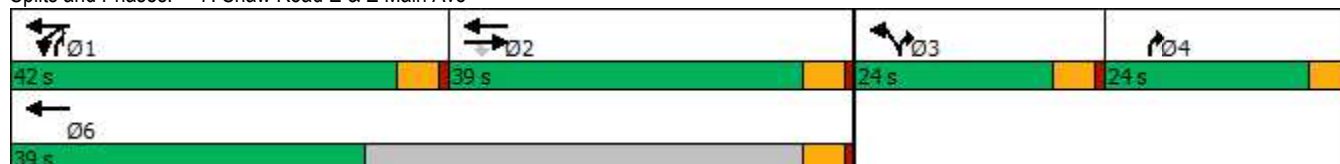

Lanes, Volumes, Timings
8: Shaw Road E & E Pioneer Way

04/14/2022



Lane Group	EBL	EBT	EBR	WBL	WBT	WBR	NBL	NBT	NBR	SBL	SBT	SBR
Lane Configurations												
Traffic Volume (vph)	178	244	256	175	255	65	140	447	63	81	886	193
Future Volume (vph)	178	244	256	175	255	65	140	447	63	81	886	193
Ideal Flow (vphpl)	1900	1900	1900	1900	1900	1900	1900	1900	1900	1900	1900	1900
Storage Length (ft)	150		0	180		0	250		0	400		0
Storage Lanes	1		1	1		0	2		0	1		0
Taper Length (ft)	25			25			25			25		
Right Turn on Red			Yes			Yes			Yes			No
Link Speed (mph)		35			35			35			35	
Link Distance (ft)		800			1013			763			634	
Travel Time (s)		15.6			19.7			14.9			12.4	
Confl. Peds. (#/hr)	1		11	11		1		7				3
Peak Hour Factor	0.94	0.94	0.94	0.94	0.94	0.94	0.94	0.94	0.94	0.94	0.94	0.94
Heavy Vehicles (%)	1%	2%	1%	2%	2%	2%	1%	2%	0%	5%	1%	1%
Shared Lane Traffic (%)												
Turn Type	pm+pt	NA	Perm	pm+pt	NA		Prot	NA		Prot	NA	
Protected Phases	7	4		3	8		5	2		1	6	
Permitted Phases	4		4	8								
Detector Phase	7	4	4	3	8		5	2		1	6	
Switch Phase												
Minimum Initial (s)	5.0	5.0	5.0	5.0	5.0		5.0	5.0		5.0	5.0	
Minimum Split (s)	11.5	43.5	43.5	11.5	53.5		11.5	36.5		11.5	39.5	
Total Split (s)	14.0	33.0	33.0	15.0	33.0		15.0	31.0		34.0	49.0	
Total Split (%)	12.4%	29.2%	29.2%	13.3%	29.2%		13.3%	27.4%		30.1%	43.4%	
Yellow Time (s)	4.5	4.5	4.5	4.5	4.5		4.5	4.5		4.5	4.5	
All-Red Time (s)	2.0	2.0	2.0	2.0	2.0		2.0	2.0		2.0	2.0	
Lost Time Adjust (s)	0.0	0.0	0.0	0.0	0.0		0.0	0.0		0.0	0.0	
Total Lost Time (s)	6.5	6.5	6.5	6.5	6.5		6.5	6.5		6.5	6.5	
Lead/Lag	Lead	Lag	Lag	Lead	Lag		Lead	Lag		Lead	Lag	
Lead-Lag Optimize?	Yes	Yes	Yes	Yes	Yes		Yes	Yes		Yes	Yes	
Recall Mode	None	None	None	None	None		None	None		None	None	

Intersection Summary

Area Type: Other

Cycle Length: 113

Actuated Cycle Length: 108.2

Natural Cycle: 120

Control Type: Actuated-Uncoordinated

Splits and Phases: 8: Shaw Road E & E Pioneer Way



HCM 6th Signalized Intersection Summary
8: Shaw Road E & E Pioneer Way

04/14/2022



Movement	EBL	EBT	EBR	WBL	WBT	WBR	NBL	NBT	NBR	SBL	SBT	SBR
Lane Configurations												
Traffic Volume (veh/h)	178	244	256	175	255	65	140	447	63	81	886	193
Future Volume (veh/h)	178	244	256	175	255	65	140	447	63	81	886	193
Initial Q (Qb), veh	0	0	0	0	0	0	0	0	0	0	0	0
Ped-Bike Adj(A_pbT)	0.99		0.98	0.99		0.99	1.00		0.99	1.00		1.00
Parking Bus, Adj	1.00	1.00	1.00	1.00	1.00	1.00	1.00	1.00	1.00	1.00	1.00	1.00
Work Zone On Approach		No			No			No			No	
Adj Sat Flow, veh/h/ln	1885	1870	1885	1870	1870	1870	1885	1870	1900	1826	1885	1885
Adj Flow Rate, veh/h	189	260	272	186	271	69	149	476	67	86	943	205
Peak Hour Factor	0.94	0.94	0.94	0.94	0.94	0.94	0.94	0.94	0.94	0.94	0.94	0.94
Percent Heavy Veh, %	1	2	1	2	2	2	1	2	0	5	1	1
Cap, veh/h	252	395	332	300	318	81	216	1166	163	111	1097	238
Arrive On Green	0.08	0.21	0.21	0.09	0.22	0.22	0.06	0.37	0.37	0.06	0.38	0.38
Sat Flow, veh/h	1795	1870	1573	1781	1433	365	3483	3126	438	1739	2925	635
Grp Volume(v), veh/h	189	260	272	186	0	340	149	270	273	86	577	571
Grp Sat Flow(s),veh/h/ln	1795	1870	1573	1781	0	1798	1742	1777	1787	1739	1791	1769
Q Serve(g_s), s	7.5	12.5	16.2	8.0	0.0	17.8	4.1	11.0	11.1	4.8	29.2	29.2
Cycle Q Clear(g_c), s	7.5	12.5	16.2	8.0	0.0	17.8	4.1	11.0	11.1	4.8	29.2	29.2
Prop In Lane	1.00		1.00	1.00		0.20	1.00		0.25	1.00		0.36
Lane Grp Cap(c), veh/h	252	395	332	300	0	398	216	663	667	111	672	664
V/C Ratio(X)	0.75	0.66	0.82	0.62	0.00	0.85	0.69	0.41	0.41	0.77	0.86	0.86
Avail Cap(c_a), veh/h	252	505	425	300	0	485	302	663	667	487	775	766
HCM Platoon Ratio	1.00	1.00	1.00	1.00	1.00	1.00	1.00	1.00	1.00	1.00	1.00	1.00
Upstream Filter(l)	1.00	1.00	1.00	1.00	0.00	1.00	1.00	1.00	1.00	1.00	1.00	1.00
Uniform Delay (d), s/veh	30.9	35.5	36.9	28.0	0.0	36.7	45.1	22.7	22.8	45.2	28.3	28.3
Incr Delay (d2), s/veh	11.7	2.1	9.5	3.8	0.0	11.8	3.9	0.4	0.4	10.7	8.6	8.8
Initial Q Delay(d3),s/veh	0.0	0.0	0.0	0.0	0.0	0.0	0.0	0.0	0.0	0.0	0.0	0.0
%ile BackOfQ(50%),veh/ln	4.3	5.8	6.9	3.6	0.0	8.9	1.9	4.5	4.6	2.4	13.5	13.4
Unsig. Movement Delay, s/veh												
LnGrp Delay(d),s/veh	42.6	37.5	46.5	31.9	0.0	48.5	49.0	23.1	23.2	55.9	36.9	37.1
LnGrp LOS	D	D	D	C	A	D	D	C	C	E	D	D
Approach Vol, veh/h		721			526			692			1234	
Approach Delay, s/veh		42.2			42.6			28.7			38.3	
Approach LOS		D			D			C			D	
Timer - Assigned Phs	1	2	3	4	5	6	7	8				
Phs Duration (G+Y+Rc), s	12.8	43.1	15.0	27.2	12.6	43.3	14.0	28.2				
Change Period (Y+Rc), s	6.5	6.5	6.5	6.5	6.5	6.5	6.5	6.5				
Max Green Setting (Gmax), s	27.5	24.5	8.5	26.5	8.5	42.5	7.5	26.5				
Max Q Clear Time (g_c+I1), s	6.8	13.1	10.0	18.2	6.1	31.2	9.5	19.8				
Green Ext Time (p_c), s	0.2	2.4	0.0	1.6	0.1	5.6	0.0	1.1				

Intersection Summary												
HCM 6th Ctrl Delay			37.8									
HCM 6th LOS			D									

Notes

User approved pedestrian interval to be less than phase max green.

Lanes, Volumes, Timings
 9: E Main Ave & SR 410 EB Ramps

04/14/2022



Lane Group	EBL	EBR	NBL	NBT	SBT	SBR	Ø4
Lane Configurations							
Traffic Volume (vph)	243	555	233	709	1077	136	
Future Volume (vph)	243	555	233	709	1077	136	
Satd. Flow (prot)	3033	1419	1770	3539	3468	0	
Flt Permitted	0.977		0.104				
Satd. Flow (perm)	3033	1419	194	3539	3468	0	
Satd. Flow (RTOR)	255	283			13		
Peak Hour Factor	0.98	0.98	0.98	0.98	0.98	0.98	
Heavy Vehicles (%)	14%	2%	2%	2%	2%	5%	
Shared Lane Traffic (%)		50%					
Lane Group Flow (vph)	531	283	238	723	1238	0	
Turn Type	Prot	Prot	pm+pt	NA	NA		
Protected Phases	8	8	1	6	2		4
Permitted Phases			6				
Detector Phase	8	8	1	6	2		
Switch Phase							
Minimum Initial (s)	6.0	6.0	6.0	6.0	6.0		6.0
Minimum Split (s)	10.5	10.5	10.5	10.5	10.5		22.0
Total Split (s)	23.0	23.0	15.0	45.0	30.0		32.0
Total Split (%)	23.0%	23.0%	15.0%	45.0%	30.0%		32%
Yellow Time (s)	3.5	3.5	3.5	3.5	3.5		2.0
All-Red Time (s)	1.0	1.0	1.0	1.0	1.0		0.0
Lost Time Adjust (s)	0.0	0.0	0.0	0.0	0.0		
Total Lost Time (s)	4.5	4.5	4.5	4.5	4.5		
Lead/Lag	Lead	Lead	Lead		Lag		Lag
Lead-Lag Optimize?	Yes	Yes	Yes		Yes		Yes
Recall Mode	None	None	None	C-Max	C-Max		Ped
Act Effct Green (s)	14.9	14.9	54.1	54.1	33.8		
Actuated g/C Ratio	0.15	0.15	0.54	0.54	0.34		
v/c Ratio	0.79	0.63	0.67	0.38	1.05		
Control Delay	30.0	11.1	29.3	14.5	63.7		
Queue Delay	0.0	0.0	0.0	0.0	0.0		
Total Delay	30.0	11.1	29.3	14.5	63.7		
LOS	C	B	C	B	E		
Approach Delay	23.5			18.2	63.7		
Approach LOS	C			B	E		

Intersection Summary

Cycle Length: 100
 Actuated Cycle Length: 100
 Offset: 0 (0%), Referenced to phase 2:SBT and 6:NBT, Start of Green
 Natural Cycle: 90
 Control Type: Actuated-Coordinated
 Maximum v/c Ratio: 1.05
 Intersection Signal Delay: 38.3
 Intersection LOS: D
 Intersection Capacity Utilization 71.0%
 ICU Level of Service C
 Analysis Period (min) 15

Splits and Phases: 9: E Main Ave & SR 410 EB Ramps

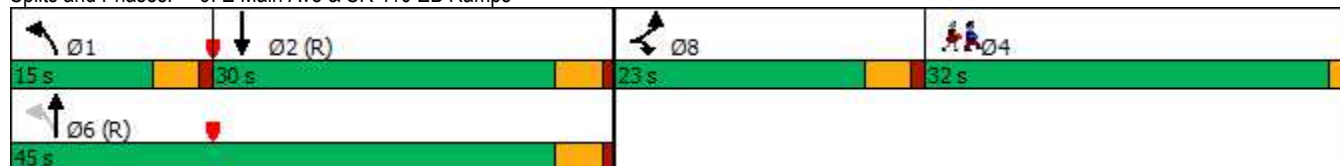

Lanes, Volumes, Timings
 10: E Main Ave & SR 410 WB Ramps/Thompson St

04/14/2022

Lane Group	EBL	EBT	EBR	WBL	WBT	WBR	NBL	NBT	NBR	SBL	SBT	SBR
Lane Configurations												
Traffic Volume (vph)	79	18	254	290	112	14	285	471	190	9	664	299
Future Volume (vph)	79	18	254	290	112	14	285	471	190	9	664	299
Ideal Flow (vphpl)	1900	1900	1900	1900	1900	1900	1900	1900	1900	1900	1900	1900
Grade (%)		0%			6%			-3%			-5%	
Storage Length (ft)	170		70	115		50	225		0	175		0
Storage Lanes	1		1	1		1	1		0	1		0
Taper Length (ft)	25			25			25			25		
Right Turn on Red			Yes			Yes			Yes			Yes
Link Speed (mph)		30			25			35			25	
Link Distance (ft)		499			309			676			392	
Travel Time (s)		11.3			8.4			13.2			10.7	
Confl. Peds. (#/hr)						6			6	6		
Peak Hour Factor	0.99	0.99	0.99	0.99	0.99	0.99	0.99	0.99	0.99	0.99	0.99	0.99
Heavy Vehicles (%)	3%	17%	1%	3%	4%	7%	3%	8%	4%	0%	3%	11%
Shared Lane Traffic (%)				32%								
Turn Type	Split	NA	Free	Split	NA	Free	pm+pt	NA		pm+pt	NA	
Protected Phases	8	8		4	4		1	6		5	2	
Permitted Phases			Free			Free	6			2		
Detector Phase	8	8		4	4		1	6		5	2	
Switch Phase												
Minimum Initial (s)	6.0	6.0		6.0	6.0		6.0	6.0		6.0	6.0	
Minimum Split (s)	10.5	10.5		10.5	10.5		10.5	28.5		10.5	10.5	
Total Split (s)	21.0	21.0		30.0	30.0		17.0	34.0		15.0	32.0	
Total Split (%)	21.0%	21.0%		30.0%	30.0%		17.0%	34.0%		15.0%	32.0%	
Yellow Time (s)	3.5	3.5		3.5	3.5		3.5	3.5		3.5	3.5	
All-Red Time (s)	1.0	1.0		1.0	1.0		1.0	1.0		1.0	1.0	
Lost Time Adjust (s)	0.0	0.0		0.0	0.0		0.0	0.0		0.0	0.0	
Total Lost Time (s)	4.5	4.5		4.5	4.5		4.5	4.5		4.5	4.5	
Lead/Lag	Lag	Lag		Lead	Lead		Lead	Lag		Lead	Lag	
Lead-Lag Optimize?	Yes	Yes		Yes	Yes		Yes	Yes		Yes	Yes	
Recall Mode	None	None		None	None		None	C-Max		None	C-Max	

Intersection Summary

Area Type: Other
 Cycle Length: 100
 Actuated Cycle Length: 100
 Offset: 61 (61%), Referenced to phase 2:SBTL and 6:NBTL, Start of Green
 Natural Cycle: 70
 Control Type: Actuated-Coordinated

Splits and Phases: 10: E Main Ave & SR 410 WB Ramps/Thompson St

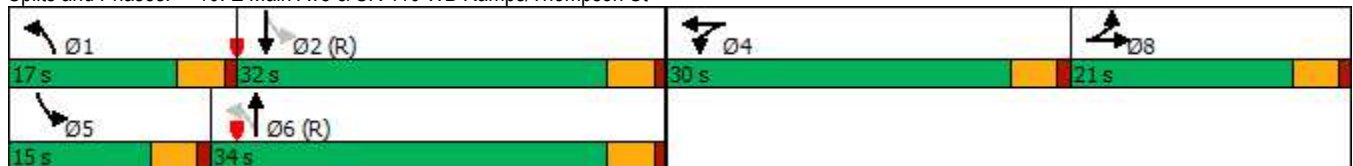

HCM 6th Signalized Intersection Summary
 10: E Main Ave & SR 410 WB Ramps/Thompson St

04/14/2022



Movement	EBL	EBT	EBR	WBL	WBT	WBR	NBL	NBT	NBR	SBL	SBT	SBR
Lane Configurations												
Traffic Volume (veh/h)	79	18	254	290	112	14	285	471	190	9	664	299
Future Volume (veh/h)	79	18	254	290	112	14	285	471	190	9	664	299
Initial Q (Qb), veh	0	0	0	0	0	0	0	0	0	0	0	0
Ped-Bike Adj(A_pbT)	1.00		1.00	1.00		1.00	1.00		0.99	1.00		0.99
Parking Bus, Adj	1.00		1.00	1.00		1.00	1.00		1.00	1.00		1.00
Work Zone On Approach		No			No			No			No	
Adj Sat Flow, veh/h/ln	1856	1648	1885	1644	1629	1584	1973	1898	1958	2097	2052	1932
Adj Flow Rate, veh/h	80	18	0	203	239	0	288	476	192	9	671	302
Peak Hour Factor	0.99	0.99	0.99	0.99	0.99	0.99	0.99	0.99	0.99	0.99	0.99	0.99
Percent Heavy Veh, %	3	17	1	3	4	7	3	8	4	0	3	11
Cap, veh/h	109	102		276	287		439	1427	572	500	1271	572
Arrive On Green	0.06	0.06	0.00	0.18	0.18	0.00	0.09	0.57	0.57	0.01	0.49	0.49
Sat Flow, veh/h	1767	1648	1598	1565	1629	1343	1879	2509	1005	1997	2607	1174
Grp Volume(v), veh/h	80	18	0	203	239	0	288	341	327	9	502	471
Grp Sat Flow(s),veh/h/ln	1767	1648	1598	1565	1629	1343	1879	1803	1711	1997	1949	1832
Q Serve(g_s), s	4.4	1.0	0.0	12.3	14.2	0.0	7.2	10.1	10.2	0.2	17.8	17.8
Cycle Q Clear(g_c), s	4.4	1.0	0.0	12.3	14.2	0.0	7.2	10.1	10.2	0.2	17.8	17.8
Prop In Lane	1.00		1.00	1.00		1.00	1.00		0.59	1.00		0.64
Lane Grp Cap(c), veh/h	109	102		276	287		439	1026	973	500	950	893
V/C Ratio(X)	0.73	0.18		0.74	0.83		0.66	0.33	0.34	0.02	0.53	0.53
Avail Cap(c_a), veh/h	292	272		399	415		495	1026	973	683	950	893
HCM Platoon Ratio	1.00	1.00	1.00	1.00	1.00	1.00	1.00	1.00	1.00	1.00	1.00	1.00
Upstream Filter(l)	1.00	1.00	0.00	1.00	1.00	0.00	0.81	0.81	0.81	1.00	1.00	1.00
Uniform Delay (d), s/veh	46.1	44.5	0.0	39.0	39.8	0.0	13.1	11.5	11.5	12.5	17.7	17.7
Incr Delay (d2), s/veh	9.1	0.8	0.0	4.0	9.3	0.0	2.2	0.7	0.8	0.0	2.1	2.2
Initial Q Delay(d3),s/veh	0.0	0.0	0.0	0.0	0.0	0.0	0.0	0.0	0.0	0.0	0.0	0.0
%ile BackOfQ(50%),veh/ln	2.2	0.4	0.0	5.0	6.4	0.0	3.0	3.9	3.8	0.1	8.4	7.9
Unsig. Movement Delay, s/veh												
LnGrp Delay(d),s/veh	55.2	45.3	0.0	43.0	49.1	0.0	15.2	12.2	12.2	12.6	19.8	19.9
LnGrp LOS	E	D		D	D		B	B	B	B	B	B
Approach Vol, veh/h		98	A		442	A		956			982	
Approach Delay, s/veh		53.4			46.3			13.1			19.8	
Approach LOS		D			D			B			B	
Timer - Assigned Phs	1	2		4	5	6		8				
Phs Duration (G+Y+Rc), s	14.0	53.2		22.1	5.8	61.4		10.7				
Change Period (Y+Rc), s	4.5	4.5		4.5	4.5	4.5		4.5				
Max Green Setting (Gmax), s	12.5	27.5		25.5	10.5	29.5		16.5				
Max Q Clear Time (g_c+I1), s	9.2	19.8		16.2	2.2	12.2		6.4				
Green Ext Time (p_c), s	0.3	3.9		1.4	0.0	3.9		0.2				

Intersection Summary

HCM 6th Ctrl Delay 23.3
 HCM 6th LOS C

Notes

User approved volume balancing among the lanes for turning movement.
 Unsignalized Delay for [EBR, WBR] is excluded from calculations of the approach delay and intersection delay.

Appendix C

True Demand Calculations

2504 E Main Ave
 True Demand Calculations
 5th St NE / E Main Ave

Peak Hour True Demand												
	E Main Ave Eastbound			E Main Ave Westbound			5th St NE Northbound			5th St NE Southbound		
	Left	Thru	Right	Left	Thru	Right	Left	Thru	Right	Left	Thru	Right
4:00 PM	1	85	8	55	114	21	4	28	29	54	126	5
4:15 PM	1	87	9	54	127	25	4	33	17	45	115	6
4:30 PM	2	63	9	58	116	23	2	30	22	60	141	5
4:45 PM	4	82	8	54	119	26	2	31	24	51	118	6
5:00 PM	2	72	14	66	115	36	2	32	20	55	102	9
5:15 PM	1	62	11	56	116	27	2	33	26	64	95	8
5:30 PM	4	81	10	58	103	17	7	24	23	44	71	5
5:45 PM	0	71	7	41	98	20	5	23	26	35	53	3
4:00 - 5:00 PM	8	317	34	221	476	95	12	122	92	210	500	22

Peak Hour TMC												
	E Main Ave Eastbound			E Main Ave Westbound			5th St NE Northbound			5th St NE Southbound		
	Left	Thru	Right	Left	Thru	Right	Left	Thru	Right	Left	Thru	Right
4:00 PM	1	79	7	53	111	20	4	26	29	53	124	4
4:15 PM	1	86	9	51	124	24	4	32	14	43	104	5
4:30 PM	2	59	9	55	114	22	2	30	22	57	130	5
4:45 PM	4	75	5	50	116	25	2	31	24	50	110	6
4:00 - 5:00 PM	8	299	30	209	465	91	12	119	89	203	468	20

DELTA = VEHICLES IN QUEUE												
	E Main Ave Eastbound			E Main Ave Westbound			5th St NE Northbound			5th St NE Southbound		
	Left	Thru	Right	Left	Thru	Right	Left	Thru	Right	Left	Thru	Right
4:00 PM	0	6	1	2	3	1	0	2	0	1	2	1
4:15 PM	0	1	0	3	3	1	0	1	3	2	11	1
4:30 PM	0	4	0	3	2	1	0	0	0	3	11	0
4:45 PM	0	7	3	4	3	1	0	0	0	1	8	0
4:00 - 5:00 PM	0	18	4	12	11	4	0	3	3	7	32	2

2504 E Main Ave
 True Demand Calculations
 2nd St NE / E Main Ave

Peak Hour True Demand												
	E Main Ave Eastbound			E Main Ave Westbound			2nd St NE Northbound			2nd St NE Southbound		
	Left	Thru	Right	Left	Thru	Right	Left	Thru	Right	Left	Thru	Right
4:00 PM	9	74	0	0	77	57	23	153	0	0	0	0
4:15 PM	6	76	0	0	71	61	24	169	0	0	0	0
4:30 PM	9	61	0	0	71	55	11	161	0	0	0	0
4:45 PM	11	70	0	0	81	53	25	144	0	0	0	0
5:00 PM	9	67	0	0	83	65	30	155	0	0	0	0
5:15 PM	17	51	0	0	90	48	29	145	0	0	0	0
5:30 PM	16	76	0	0	77	56	22	133	0	0	0	0
5:45 PM	13	53	0	0	63	38	25	134	0	0	0	0
4:15 - 5:15 PM	35	274	0	0	306	234	90	629	0	0	0	0

Peak Hour TMC												
	E Main Ave Eastbound			E Main Ave Westbound			2nd St NE Northbound			2nd St NE Southbound		
	Left	Thru	Right	Left	Thru	Right	Left	Thru	Right	Left	Thru	Right
4:15 PM	6	73	0	0	65	57	24	167	0	0	0	0
4:30 PM	9	61	0	0	71	55	11	159	0	0	0	0
4:45 PM	11	70	0	0	63	53	24	140	0	0	0	0
5:00 PM	9	67	0	0	81	62	29	155	0	0	0	0
4:15 - 5:15 PM	35	271	0	0	280	227	88	621	0	0	0	0

DELTA = VEHICLES IN QUEUE												
	E Main Ave Eastbound			E Main Ave Westbound			2nd St NE Northbound			2nd St NE Southbound		
	Left	Thru	Right	Left	Thru	Right	Left	Thru	Right	Left	Thru	Right
4:15 PM	0	3	0	0	6	4	0	2	0	0	0	0
4:30 PM	0	0	0	0	0	0	0	2	0	0	0	0
4:45 PM	0	0	0	0	18	0	1	4	0	0	0	0
5:00 PM	0	0	0	0	2	3	1	0	0	0	0	0
4:15 - 5:15 PM	0	3	0	0	26	7	2	8	0	0	0	0

2504 E Main Ave
 True Demand Calculations
 Shaw Rd E / E Main Ave

Peak Hour True Demand												
	E Main Ave Eastbound			E Main Ave Westbound			Shaw Rd E Northbound			Shaw Rd E Southbound		
	Left	Thru	Right	Left	Thru	Right	Left	Thru	Right	Left	Thru	Right
4:00 PM	0	108	50	223	181	0	45	0	112	0	0	0
4:15 PM	0	95	44	210	169	0	65	0	120	0	0	0
4:30 PM	0	95	55	255	171	0	54	0	135	0	0	0
4:45 PM	0	87	58	302	194	0	50	0	121	0	0	0
5:00 PM	0	108	55	286	175	0	43	0	128	0	0	0
5:15 PM	0	94	39	287	164	0	50	0	126	0	0	0
5:30 PM	0	83	55	234	176	0	52	0	121	0	0	0
5:45 PM	0	71	44	198	123	0	52	0	96	0	0	0
4:30 - 5:30 PM	0	384	207	1130	704	0	197	0	510	0	0	0

Peak Hour TMC												
	E Main Ave Eastbound			E Main Ave Westbound			Shaw Rd E Northbound			Shaw Rd E Southbound		
	Left	Thru	Right	Left	Thru	Right	Left	Thru	Right	Left	Thru	Right
4:30 PM	0	89	55	232	157	0	52	0	135	0	0	0
4:45 PM	0	87	56	282	188	0	48	0	111	0	0	0
5:00 PM	0	104	55	256	166	0	42	0	128	0	0	0
5:15 PM	0	86	36	271	159	0	47	0	119	0	0	0
4:30 - 5:30 PM	0	366	202	1041	670	0	189	0	493	0	0	0

DELTA = VEHICLES IN QUEUE												
	E Main Ave Eastbound			E Main Ave Westbound			Shaw Rd E Northbound			Shaw Rd E Southbound		
	Left	Thru	Right	Left	Thru	Right	Left	Thru	Right	Left	Thru	Right
4:30 PM	0	6	0	23	14	0	2	0	0	0	0	0
4:45 PM	0	0	2	20	6	0	2	0	10	0	0	0
5:00 PM	0	4	0	30	9	0	1	0	0	0	0	0
5:15 PM	0	8	3	16	5	0	3	0	7	0	0	0
4:30 - 5:30 PM	0	18	5	89	34	0	8	0	17	0	0	0

2504 E Main Ave
 True Demand Calculations
 Shaw Rd E / E Pioneer

Peak Hour True Demand												
	E Pioneer Eastbound			E Pioneer Westbound			Shaw Rd E Northbound			Shaw Rd E Southbound		
	Left	Thru	Right	Left	Thru	Right	Left	Thru	Right	Left	Thru	Right
4:00 PM	34	75	54	39	77	22	48	120	12	15	212	47
4:15 PM	46	56	63	36	69	15	41	100	20	16	196	41
4:30 PM	48	71	42	57	83	22	53	125	27	23	231	46
4:45 PM	49	52	59	45	64	15	35	99	9	25	268	63
5:00 PM	53	75	86	43	78	16	40	111	12	18	267	52
5:15 PM	47	50	78	40	43	12	22	132	15	14	235	59
5:30 PM	60	53	59	44	60	14	32	94	7	23	255	49
5:45 PM	24	59	56	33	62	13	29	105	23	24	280	40
4:30 - 5:30 PM	197	248	265	185	268	65	150	467	63	80	1001	220

Peak Hour TMC												
	E Pioneer Eastbound			E Pioneer Westbound			Shaw Rd E Northbound			Shaw Rd E Southbound		
	Left	Thru	Right	Left	Thru	Right	Left	Thru	Right	Left	Thru	Right
4:30 PM	42	70	42	54	81	21	50	123	27	21	207	44
4:45 PM	45	51	54	42	60	14	34	96	9	23	243	56
5:00 PM	48	75	86	40	75	14	37	93	12	13	219	41
5:15 PM	43	48	74	39	39	11	19	131	15	14	207	52
4:30 - 5:30 PM	178	244	256	175	255	60	140	443	63	71	876	193

DELTA = VEHICLES IN QUEUE												
	E Pioneer Eastbound			E Pioneer Westbound			Shaw Rd E Northbound			Shaw Rd E Southbound		
	Left	Thru	Right	Left	Thru	Right	Left	Thru	Right	Left	Thru	Right
4:30 PM	6	1	0	3	2	1	3	2	0	2	24	2
4:45 PM	4	1	5	3	4	1	1	3	0	2	25	7
5:00 PM	5	0	0	3	3	2	3	18	0	5	48	11
5:15 PM	4	2	4	1	4	1	3	1	0	0	28	7
4:30 - 5:30 PM	19	4	9	10	13	5	10	24	0	9	125	27

Appendix D

Trip Generation Calculations

IDI Industrial - 2504 E Main Avenue (Puyallup)
Trip Generation Summary

Proposed Land Use	Units ¹	ITE LUC ²	Directional Distribution ²		Trip Rate or Equation ²	Trips Generated		
			In	Out		In	Out	Total
Daily								
Manufacturing	210,376 GFA	140	50%	50%	4.75	499	500	999
AM Peak Hour								
Manufacturing	210,376 GFA	140	76%	24%	0.68	109	34	143
PM Peak Hour								
Manufacturing	210,376 GFA	140	31%	69%	0.74	48	108	156

TRUCKS									
Trip Rate ²	Distribution ²		Truck Trips Generated			Non-Truck Trip Generation			
	In	Out	In	Out	Total	In	Out	Total	
0.45	50%	50%	47	48	95	452	452	904	
0.03	56%	44%	3	3	6	106	31	137	
0.03	41%	59%	2	4	6	46	104	150	

Notes:

¹ GFA = Gross Floor Area.

² Land Use Code, trip rates/equations and directional splits based on ITE *Trip Generation* Manual, 11th Edition, 2021.

Appendix E

Signal Warrant Analysis

**2504 Main Ave
E Main Ave / Site Access
TENW Project #2022-072**

Existing Year = 2022 Future Year = 2022 % Growth = 2.0%

Time	Tuesday 3/22/22				Wednesday 3/23/22				Thursday 3/24/22				2022 Existing - 3 Day Average				Total Entering Volume
	EB (E Main Ave)	WB (E Main Ave)	NB (Site Access)	SB (Apt Driveway)	EB (E Main Ave)	WB (E Main Ave)	NB (Site Access)	SB (Apt Driveway)	EB (E Main Ave)	WB (E Main Ave)	NB (Site Access)	SB (Apt Driveway)	EB (E Main Ave)	WB (E Main Ave)	NB (Site Access)	SB (Apt Driveway)	
12:00 AM	23	32	0	0	33	24	1	2	26	27	2	2					0
1:00 AM	18	30	0	0	14	25	2	2	21	25	3	3					0
2:00 AM	16	17	3	3	13	12	1	1	17	20	5	5					0
3:00 AM	39	37	4	4	41	32	1	1	42	34	2	2					0
4:00 AM	73	66	17	17	73	59	12	12	71	74	22	22					0
5:00 AM	223	173	31	31	204	174	29	29	211	155	28	28	213	167	29	29	409
6:00 AM	304	313	43	43	280	327	45	45	261	307	33	33	282	316	40	40	638
7:00 AM	419	491	43	43	373	486	45	45	348	459	50	50	380	479	46	46	905
8:00 AM	358	425	50	50	333	428	50	50	337	450	45	45	343	434	48	48	825
9:00 AM	329	414	37	37	317	394	50	50	333	413	43	43	326	407	43	43	777
10:00 AM	374	402	23	23	347	390	28	28	381	458	27	27	367	417	26	26	810
11:00 AM	415	467	33	33	382	450	44	44	427	476	33	33	408	464	37	37	909
12:00 PM	472	510	40	40	461	491	39	39	473	494	36	36	469	498	38	38	1,005
1:00 PM	413	480	37	37	419	485	37	37	508	459	39	39	447	475	38	38	959
2:00 PM	474	546	32	32	491	536	48	48	488	564	39	39	484	549	40	40	1,073
3:00 PM	486	732	46	46	512	742	41	41	482	662	44	44	493	712	44	44	1,249
4:00 PM	571	877	49	49	527	850	49	49	530	830	45	45	543	852	48	48	1,443
5:00 PM	544	789	41	41	479	754	46	46	538	812	33	33	520	785	40	40	1,345
6:00 PM	407	450	33	33	391	431	26	26	380	471	37	37	393	451	32	32	875
7:00 PM	280	290	37	37	285	294	36	36	324	301	29	29	296	295	34	34	625
8:00 PM	245	182	21	21	226	193	15	15	276	207	20	20					0
9:00 PM	161	113	11	11	156	121	6	6	131	121	9	9					0
10:00 PM	63	75	10	10	61	88	4	4	83	83	10	10					0
11:00 PM	57	66	4	4	44	64	6	6	57	46	4	4					0
TOTAL	6,764	7,977	0	645	6,462	7,850	0	661	6,745	7,948	0	638	5,964	7,301	0	583	13,847

Time	2022 Without Project				Total Entering Volume
	EB (E Main Ave)	WB (E Main Ave)	NB (Site Access)	SB (Apt Driveway)	
12:00 AM					
1:00 AM					
2:00 AM					
3:00 AM					
4:00 AM					
5:00 AM	213	167	0	29	409
6:00 AM	282	316	0	40	638
7:00 AM	380	479	0	46	905
8:00 AM	343	434	0	48	825
9:00 AM	326	407	0	43	776
10:00 AM	367	417	0	26	810
11:00 AM	408	464	0	37	909
12:00 PM	469	498	0	38	1,005
1:00 PM	447	475	0	38	960
2:00 PM	484	549	0	40	1,073
3:00 PM	493	712	0	44	1,249
4:00 PM	543	852	0	48	1,443
5:00 PM	520	785	0	40	1,345
6:00 PM	393	451	0	32	876
7:00 PM	296	295	0	34	625
8:00 PM					
9:00 PM					
10:00 PM					
11:00 PM					
TOTAL	5,964	7,301	0	583	13,848

Time	Project Trip Assignment				Total Entering Volume
	EB (E Main Ave)	WB (E Main Ave)	NB (Site Access)	SB (Apt Driveway)	
12:00 AM					
1:00 AM					
2:00 AM					
3:00 AM					
4:00 AM					
5:00 AM	4	8	1	0	13
6:00 AM	24	45	11	0	80
7:00 AM	38	71	34	0	143
8:00 AM	9	16	11	0	36
9:00 AM	6	10	12	0	28
10:00 AM	5	9	13	0	27
11:00 AM	9	16	20	0	45
12:00 PM	13	25	26	0	64
1:00 PM	10	18	29	0	57
2:00 PM	8	14	30	0	52
3:00 PM	14	26	87	0	127
4:00 PM	17	31	108	0	156
5:00 PM	4	7	41	0	52
6:00 PM	2	3	11	0	16
7:00 PM	2	3	6	0	11
8:00 PM					
9:00 PM					
10:00 PM					
11:00 PM					
TOTAL	165	302	440	0	907

Time	2022 With-Project				Total Entering Volume
	EB (E Main Ave)	WB (E Main Ave)	NB (Site Access)	SB (Apt Driveway)	
12:00 AM					
1:00 AM					
2:00 AM					
3:00 AM					
4:00 AM					
5:00 AM	217	175	1	29	422
6:00 AM	306	361	11	40	718
7:00 AM	418	550	34	46	1,048
8:00 AM	352	450	11	48	861
9:00 AM	332	417	12	43	804
10:00 AM	372	426	13	26	837
11:00 AM	417	480	20	37	954
12:00 PM	482	523	26	38	1,069
1:00 PM	457	493	29	38	1,017
2:00 PM	492	563	30	40	1,125
3:00 PM	507	738	87	44	1,376
4:00 PM	560	883	108	48	1,599
5:00 PM	524	792	41	40	1,397
6:00 PM	395	454	11	32	892
7:00 PM	298	298	6	34	636
8:00 PM					
9:00 PM					
10:00 PM					
11:00 PM					
TOTAL	6,129	7,603	440	583	14,755

2504 Main Ave
TENW Project #2022-072

Signal Warrant Analysis for E Main Ave / Site Access
 2022 With-Project

Warrant 1 - Eight Hour Vehicular Volume
Condition A - Minimum Vehicular Volume

Hour Begins	Minor Approach Site Access Highest NB/SB (1)	Major Approach E Main Ave Total EB & WB (2)	MUTCD (1) Warrant 1A
5:00	29	392	
6:00	40	667	
7:00	46	968	
8:00	48	802	
9:00	43	749	
10:00	26	798	
11:00	37	897	
12:00	38	1,005	
13:00	38	950	
14:00	40	1,055	
15:00	87	1,245	
16:00	108	1,443	
17:00	41	1,316	
18:00	32	849	
19:00	34	596	

WARRANT MET (3) = NO

Notes:

- (1) MUTCD - Manual on Uniform Traffic Control Devices, 2009.
- (2) Three-day average of 24-hour volumes conducted on 3/22/22, 3/23/22, and 3/24/22.
- (3) Signal warrant satisfied when traffic volumes exist for each of any 8 hours of an average day.

MUTCD Warrant Requirements

Warrant 1, Condition A: Minimum Vehicular Volume

Minimum volume of 600 vehicles per hour on 2-lane major street (both approaches) and 150 vehicles per hour on 1-lane minor street approach.

2504 Main Ave
TENW Project #2022-072

Signal Warrant Analysis for E Main Ave / Site Access
 2022 With-Project

Warrant 1 - Eight Hour Vehicular Volume
Condition B - Interruption of Continuous Traffic

Hour Begins	Minor Approach Site Access Highest NB/SB (1)	Major Approach E Main Ave Total EB & WB (2)	MUTCD (1) Warrant 1B
5:00	29	392	
6:00	40	667	
7:00	46	968	
8:00	48	802	
9:00	43	749	
10:00	26	798	
11:00	37	897	
12:00	38	1,005	
13:00	38	950	
14:00	40	1,055	
15:00	87	1,245	YES
16:00	108	1,443	YES
17:00	41	1,316	
18:00	32	849	
19:00	34	596	

WARRANT MET (3) = NO

Notes:

- (1) MUTCD - Manual on Uniform Traffic Control Devices, 2009.
- (2) Three-day average of 24-hour volumes conducted on 3/22/22, 3/23/22, and 3/24/22.
- (3) Signal warrant satisfied when traffic volumes exist for each of any 8 hours of an average day.

MUTCD Warrant Requirements

Warrant 1, Condition B: Interruption of Continuous Traffic

Minimum volume of 900 vehicles per hour on 2-lane major street (both approaches) and 75 vehicles per hour on 1-lane minor street approach.

2504 Main Ave
TENW Project #2022-072

Signal Warrant Analysis for E Main Ave / Site Access
 2022 With-Project

Warrant 1 - Eight Hour Vehicular Volume
Combination of Condition A and Condition B

Hour Begins	Minor Approach Site Access Highest NB/SB (1)	Major Approach E Main Ave Total EB & WB (2)	MUTCD (1)		
			Warrant 1 A/B	80% Condition A	80% Condition B
5:00	29	392			
6:00	40	667			
7:00	46	968			
8:00	48	802			
9:00	43	749			
10:00	26	798			
11:00	37	897			
12:00	38	1,005			
13:00	38	950			
14:00	40	1,055			
15:00	87	1,245			YES
16:00	108	1,443			YES
17:00	41	1,316			
18:00	32	849			
19:00	34	596			

WARRANT MET (3) = NO

Notes:

- (1) MUTCD - Manual on Uniform Traffic Control Devices, 2009.
- (2) Three-day average of 24-hour volumes conducted on 3/22/22, 3/23/22, and 3/24/22.
- (3) Signal warrant satisfied when traffic volumes exist for each of any 8 hours of an average day.

MUTCD Warrant Requirements

Warrant 1: Combination of A and B

The combination of warrants is satisfied where Condition A and Condition B are satisfied to the extent of 80 percent or more of the stated values.

NOTE:

This combination warrant only applies after an adequate trial of other alternatives that could cause less delay and inconvenience to traffic has failed to solve the traffic problems.

2504 Main Ave
TENW Project #2022-072

Signal Warrant Analysis for E Main Ave / Site Access
 2022 With-Project

Warrant 2 - Four Hour Vehicular Volume

Hour Begins	Minor Approach Site Access Highest NB/SB (1)	Major Approach E Main Ave Total EB & WB (2)	MUTCD (1)
			Warrant 2
5:00	29	392	
6:00	40	667	
7:00	46	968	
8:00	48	802	
9:00	43	749	
10:00	26	798	
11:00	37	897	
12:00	38	1,005	
13:00	38	950	
14:00	40	1,055	
15:00	87	1,245	
16:00	108	1,443	
17:00	41	1,316	
18:00	32	849	
17:00	34	596	

WARRANT MET (3) = NO

Notes:

- (1) MUTCD - Manual on Uniform Traffic Control Devices, 2009.
- (2) Three-day average of 24-hour volumes conducted on 3/22/22, 3/23/22, and 3/24/22.
- (3) Signal warrant satisfied when traffic volumes exist for each of any 4 hours of an average day.

MUTCD Warrant Requirements

Warrant 2: Four Hour Vehicular Volume

The plotted points representing the vehicles per hour on the major street (total of both approaches) and the corresponding vehicles per hour on the higher volume minor street approach (one direction only) all fall above the applicable curve in Figure 4C-1 for the existing combination of approach lanes.

Signal Warrant Analysis for E Main Ave / Site Access
2022 With-Project

Warrant 2 - Four Hour Vehicular Volume

Figure 4C-1. Warrant 2, Four-Hour Vehicular Volume

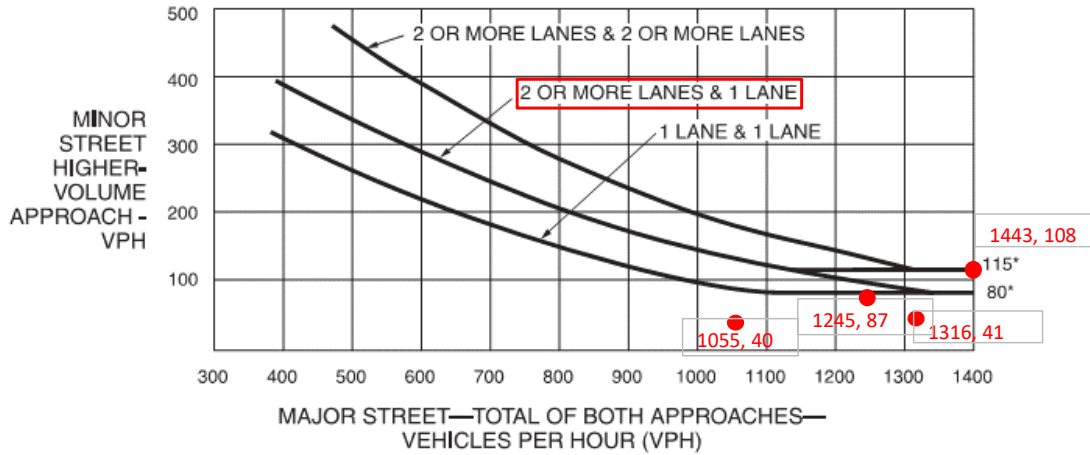

*Note: 115 vph applies as the lower threshold volume for a minor-street approach with two or more lanes and 80 vph applies as the lower threshold volume for a minor-street approach with one lane.

WARRANT MET (2) = NO

Notes:

- (1) The four highest hourly minor/major approach volumes as shown in the data for Warrant 1.
- (2) The signal warrant is satisfied when the conditions given below exist for each of any 4 hours of an average day.

MUTCD Warrant Requirements

Warrant 2: Four Hour Vehicular Volume

The plotted points representing the vehicles per hour on the major street (total of both approaches) and the corresponding vehicles per hour on the higher volume minor street approach (one direction only) all fall above the applicable curve in Figure 4C-1 for the existing combination of approach lanes. On the minor street, the higher volume shall not be required to be on the same approach during each of these 4 hours.

Signal Warrant Analysis for E Main Ave / Site Access
2022 With-Project

Warrant 3 - Peak Hour (PM Peak Hour)

Category A

This warrant is met if all three of the following conditions exist for the same 1 hour (any four consecutive 15-minute periods) of an average day:

1. The total stopped delay experienced by the traffic on one minor-street approach (one direction only) controlled by a STOP sign equals or exceeds: 4 vehicle-hours for a one-lane approach; or 5 vehicle-hours for a two-lane approach

E Main Ave / Site Access	SB approach (2 lanes)		
Control Delay (sec/veh) =	39.5	sec/veh	**Based on results from Synchro analysis
Stopped Delay (sec/veh) =	30.4	sec/veh	
Total Volume (veh/hr) =	49	veh/hour	
Vehicle-Hours =	0.41	veh-hours	
CONDITION 1 MET =	NO		

2. The volume on the same minor-street approach (one direction only) equals or exceeds 100 vehicles per hour for one moving lane of traffic or 150 vehicles per hour for two moving lanes.

E Main Ave / Site Access, SB approach volume =	49
CONDITION 2 MET =	NO

3. The total entering volume serviced during the hour equals or exceeds 650 vehicle per hour for intersections with three approaches or 800 vehicles per hour for intersections with four or more approaches.

E Main Ave / Site Access, Total approach volume =	1,650
CONDITION 3 MET =	YES

WARRANT MET =	NO
----------------------	-----------

NOTE:

This signal warrant shall be applied only in unusual cases, such as office complexes, manufacturing plants, industrial complexes, or high-occupancy vehicle facilities that attract or discharge large numbers of vehicles over a short time.

Signal Warrant Analysis for E Main Ave / Site Access
2022 With-Project

Warrant 3 - Peak Hour (PM Peak Hour)

Category A

This warrant is met if all three of the following conditions exist for the same 1 hour (any four consecutive 15-minute periods) of an average day:

1. The total stopped delay experienced by the traffic on one minor-street approach (one direction only) controlled by a STOP sign equals or exceeds: 4 vehicle-hours for a one-lane approach; or 5 vehicle-hours for a two-lane approach

E Main Ave / Site Access	NB approach (1 lane)		
Control Delay (sec/veh) =	16.2	sec/veh	**Based on results from Synchro analysis
Stopped Delay (sec/veh) =	12.5	sec/veh	
Total Volume (veh/hr) =	108	veh/hour	
Vehicle-Hours =	0.37	veh-hours	
CONDITION 1 MET =	NO		

2. The volume on the same minor-street approach (one direction only) equals or exceeds 100 vehicles per hour for one moving lane of traffic or 150 vehicles per hour for two moving lanes.

E Main Ave / Site Access, NB approach volume =	108
CONDITION 2 MET =	YES

3. The total entering volume serviced during the hour equals or exceeds 650 vehicle per hour for intersections with three approaches or 800 vehicles per hour for intersections with four or more approaches.

E Main Ave / Site Access, Total approach volume =	1,650
CONDITION 3 MET =	YES

WARRANT MET =	NO
----------------------	-----------

NOTE:

This signal warrant shall be applied only in unusual cases, such as office complexes, manufacturing plants, industrial complexes, or high-occupancy vehicle facilities that attract or discharge large numbers of vehicles over a short time.

2504 Main Ave
TENW Project #2022-072

Signal Warrant Analysis for E Main Ave / Site Access
 2022 With-Project

Warrant 3 - Peak Hour
Category B

Hour Begins	Minor Approach Site Access Highest NB/SB (1)	Major Approach E Main Ave Total EB & WB (2)	MUTCD (1)
			Warrant 3
5:00	29	392	
6:00	40	667	
7:00	46	968	
8:00	48	802	
9:00	43	749	
10:00	26	798	
11:00	37	897	
12:00	38	1,005	
13:00	38	950	
14:00	40	1,055	
15:00	87	1,245	
16:00	108	1,443	
17:00	41	1,316	
18:00	32	849	
19:00	34	596	
WARRANT MET (3) =			NO

Notes:

- (1) MUTCD - Manual on Uniform Traffic Control Devices, 2009.
- (2) Three-day average of 24-hour volumes conducted on 3/22/22, 3/23/22, and 3/24/22.
- (3) Signal warrant satisfied when traffic volumes exist for one hour of an average day.

MUTCD Warrant Requirements

Warrant 3: Peak Hour - Condition B

The plotted points representing the vehicles per hour on the major street (total of both approaches) and the corresponding vehicles per hour on the higher volume minor street approach (one direction only) for one hour (any four consecutive 15-minute periods) of an average day falls above the curve in Figure 4C-3 for the existing combination of approach lanes.

NOTE:

This signal warrant shall only be applied in unusual cases. Such cases include, but are not limited to, office complexes, manufacturing plants, industrial complexes, or high-occupancy vehicle facilities that attract or discharge large numbers of vehicles over a short time.

Signal Warrant Analysis for E Main Ave / Site Access
2022 With-Project

Warrant 3 - Peak Hour
Category B

Figure 4C-3. Warrant 3, Peak Hour

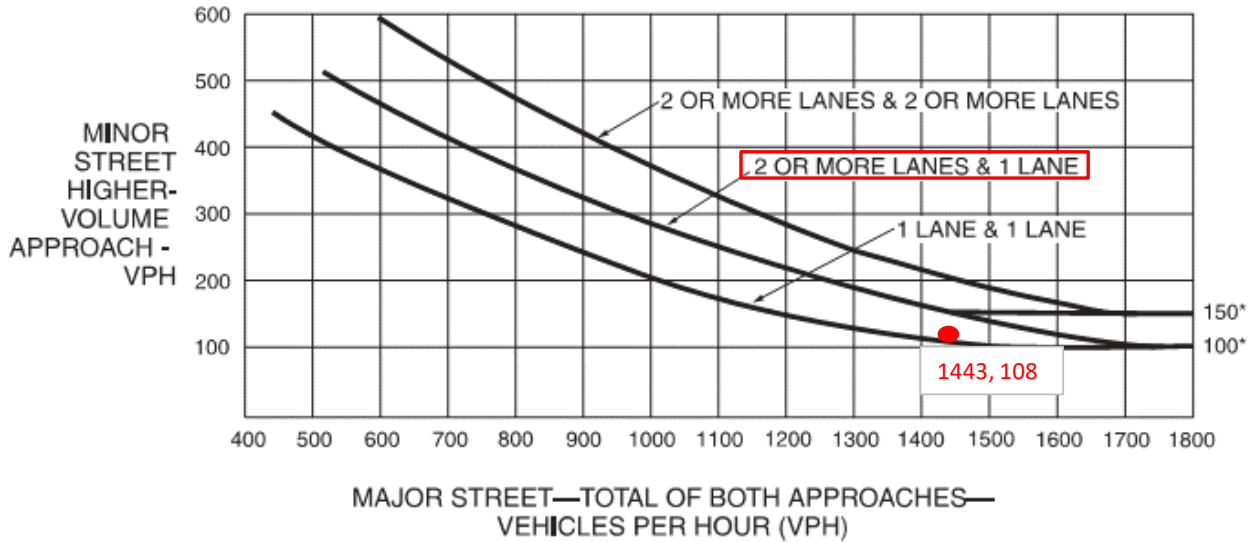

*Note: 150 vph applies as the lower threshold volume for a minor-street approach with two or more lanes and 100 vph applies as the lower threshold volume for a minor-street approach with one lane.

WARRANT MET (2) = NO

Notes:

- (1) The highest hourly minor/major approach volumes as shown in the data for Warrant 1.
- (2) The signal warrant is satisfied when the conditions given below exist for one hour of an average day.

MUTCD Warrant Requirements

Warrant 3: Peak Hour - Condition B

The plotted point representing the vehicles per hour on the major street (total of both approaches) and the corresponding vehicles per hour on the higher-volume minor street approach (one direction only) for 1 hour of an average day falls above the applicable curve in Figure 4C-3 for the existing combination of approach lanes.

NOTE:

This signal warrant shall only be applied in unusual cases. Such cases include, but are not limited to, office complexes, manufacturing plants, industrial complexes, or high-occupancy vehicle facilities that attract or discharge large numbers of vehicles over a short time.

Appendix F

Right-Turn Lane Evaluation

Exhibit 1310-11 Right-Turn Lane Guidelines

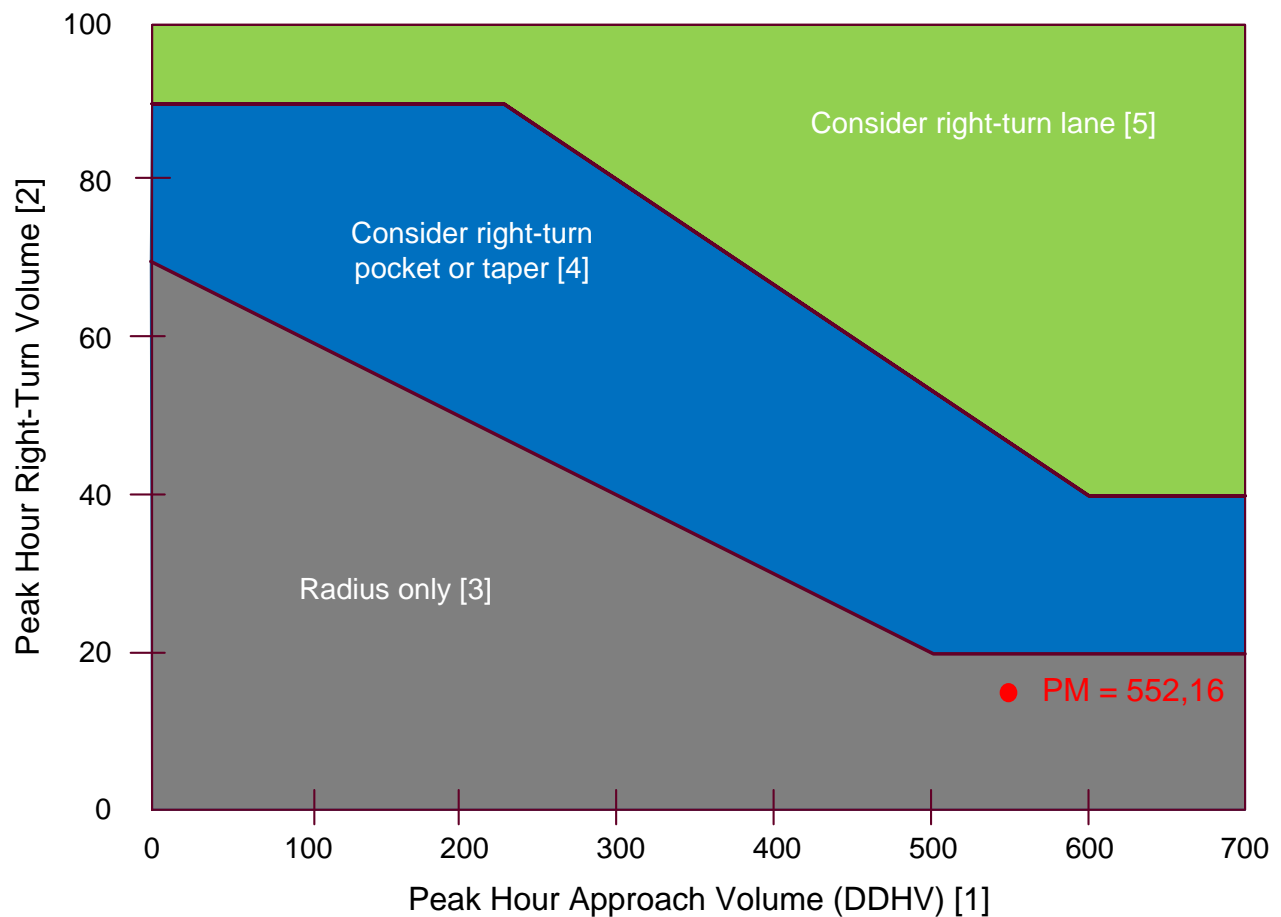

Notes:

- [1] For two-lane highways, use the peak hour DDHV (through + right-turn).
For multilane, high-speed highways (posted speed 45 mph or above), use the right-lane peak hour approach volume (through + right-turn).
- [2] When all three of the following conditions are met, reduce the right-turn DDHV by 20:
- The posted speed is 45 mph or below
 - The right-turn volume is greater than 40 VPH
 - The peak hour approach volume (DDHV) is less than 300 VPH
- [3] For right-turn corner design, see Exhibit 1310-6.
- [4] For right-turn pocket or taper design, see Exhibit 1310-12.
- [5] For right-turn lane design, see Exhibit 1310-13.