

SUBMITTAL 1+2

**Dealer Name**  
Lakeside Door

**Reference Number**  
1995056.2.04249438

**Date**  
October 25, 2022

**PO Number/Job Name**  
Qt/hopkins

**Quantity**  
1

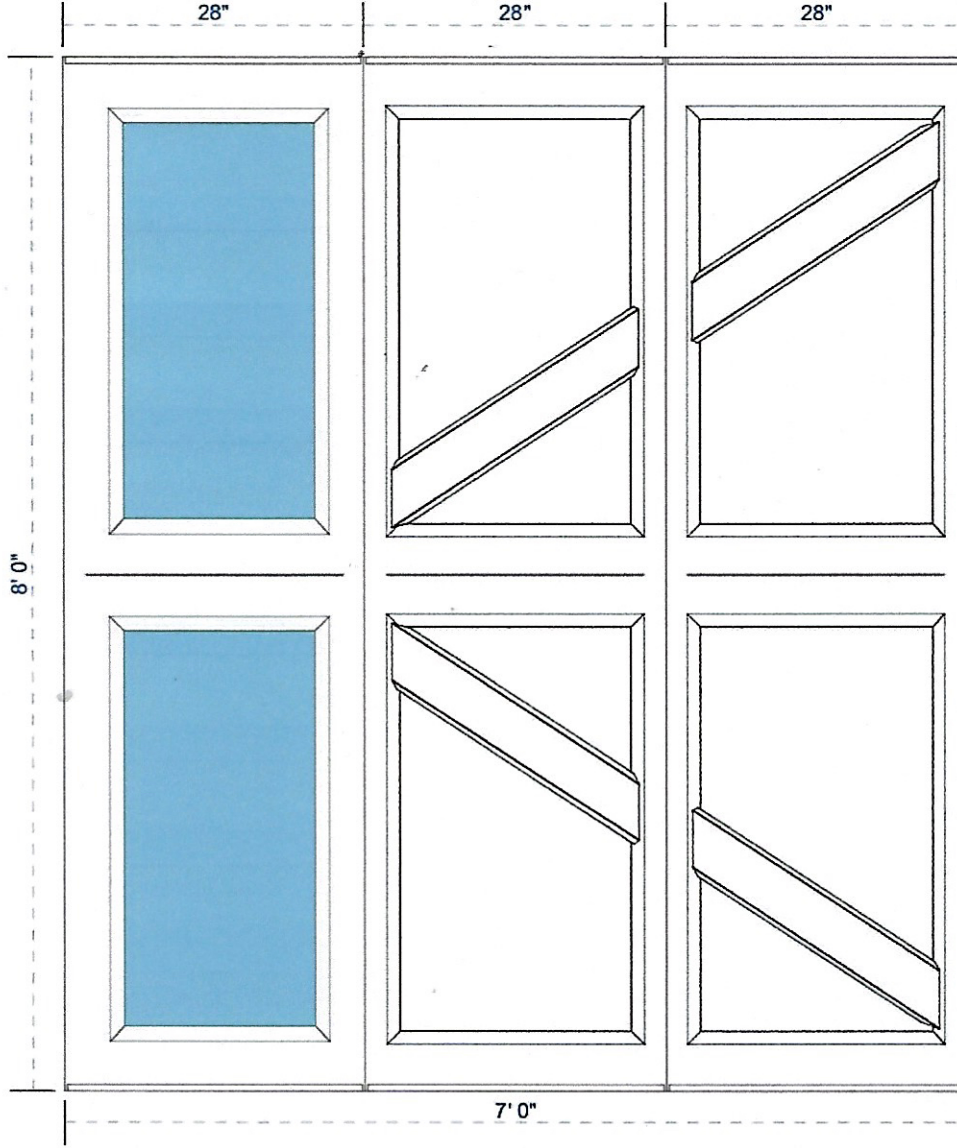

SUBMITTAL ITEM 3

homedepot.com

85%

Close X

# 8 ft. Corrugated Galvanized Steel 31-Gauge Roof Panel by Gibraltar Building Products

Related Videos & 360° View

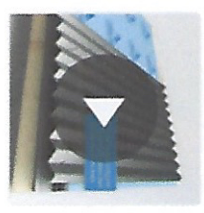

Product Images

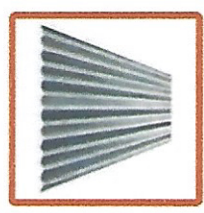

Feedback

Live Chat



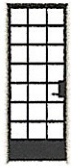

RUSTICA  
CROPLAND  
W REINFORCED  
METAL GLASS



SUBMITTAL ITEM

4

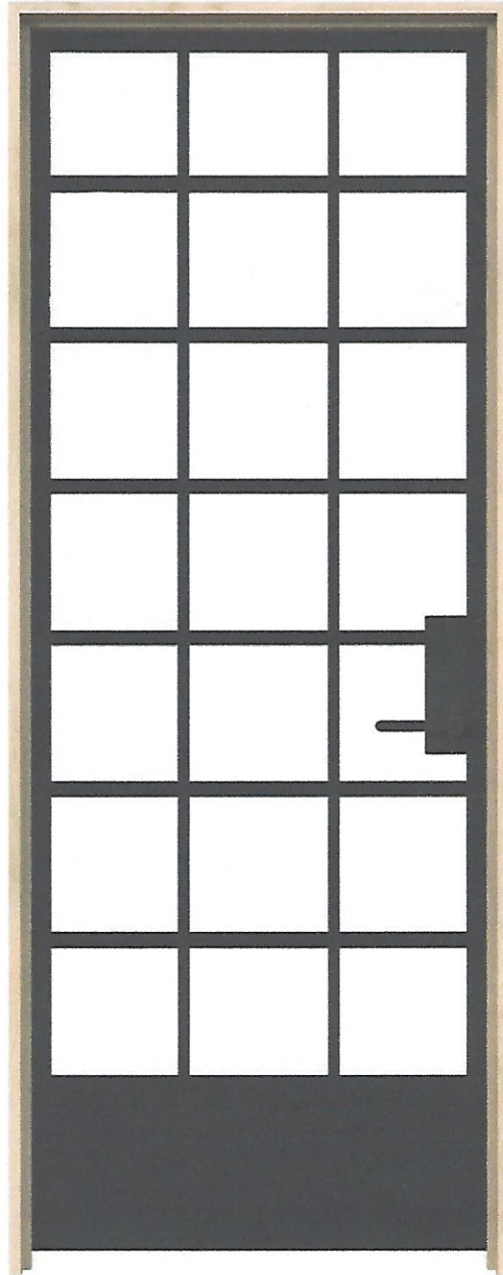

Hi there,  
question

Get  
10% Off



- ▶ Select Bore Hole Backset 2-3/4 in
- ▶ Add Hinges? No
- ▶ Select Hinge Prep \$75 Rustica Standard
- ▶ Select Handing Left Hand Inswing

**NOTICE:** Exterior Doors with door knob boring automatically get a Double Bore





## SPECIFICATIONS

## GENERAL

Single Hung windows shall be Marlin Series 3502 thermally improved as manufactured by Marlin Windows, and shall conform to ANSI/AAMA 101-88 DHC-C30. Series 3502 shall have a AAMA1503 CRF of 58 and an NFRC 500 CR of not less than 32.

## MATERIALS

All frame and sash members shall be aluminum extrusions of 6063-T5 alloy & temp. Frame and sash members shall have a rigid polyurethane "thermal barrier" as an integral part of the extrusion which eliminates all direct contact between the interior and exterior aluminum section.

## FINISH

Standard architectural Class II anodic color conforming to Aluminum Association AA-M12-C22-A34 for dark bronze or AA-M12-C22-A31 for clear anodize. (Architectural Class I and Class II anodic finishes and organic coatings available).

## CONSTRUCTION

Frame members shall be 3 3/8" in depth. Frame and vent corners shall be fabricated to form tight mitered joints. Fixed interlock members shall be fabricated to form tight butt-joints where joined to frame members. All joinery fastened securely with stainless steel self-tapping screws and sealed to prevent moisture and air infiltration. Sill members shall allow drainage of moisture to the exterior, but prevent direct inflow of wind, moisture, and dirt. Sill tracks shall be extruded as an integral part of the sill member. Extruded aluminum glass stops shall be fabricated to form tight butt-joints.

## HARDWARE

The sliding vent shall be counterbalanced with concealed block and tackle hardware. Rigid vinyl guides shall be located on the top and bottom rails at each corner of the sash to assure smooth operation. A continuous pull handle shall be part of the interlock stile. A thumb operated latch shall be attached to the interlock stile and shall engage a channel in the fixed interlock when the sash is fully closed.

## WEATHERSTRIPPING

Ventilating sash shall have continuous weather stripping of silicone treated wool pile incorporating a polypropylene fin to ensure longer life with better resistance to wind and moisture infiltration. Weather stripping shall extend around the entire perimeter of the vent.

## GLAZING

Marlin Series 3502 shall be glazed with 1" overall insulating glass. The ventilator shall be "marine" type glazed with a continuous vinyl channel gasket. The fixed glass shall be set on blocks, back bedded in foam glazing tape and retained by an extruded aluminum stop.

## OPTIONAL SCREEN

Screen frames shall be fabricated from roll form aluminum, finish to match window. Screen cloth to be 18 x 16 fiberglass mesh held in aluminum screen frame with a tight fitting continuous vinyl spline. Two leaf springs shall be attached to the top rail of the screen and two metal pull tabs shall be attached at the bottom rail and held in place by the screen spline.

## INSTALLATION

Windows shall be installed straight, plumb, and level without twisting and securely anchored in place. Openings shall be properly prepared to provide sufficient space at jambs, head and sill to compensate for normal construction movement without effecting intended use.

## ANCHORING INSTRUCTIONS FOR NAIL FIN WINDOWS

Secure with screws 4" to 6" off of each corner, then secure the remainder of the window with spacing no greater than 18" for the entire perimeter of the frame. This includes the head of the windows. Marlin suggests using a #8 screw, 2 1/2" or longer.

## PROTECTION AND CLEANING

The General Contractor shall provide adequate protection of the aluminum and glass surface from damage by grinding compound, lime, acids, cement or other contaminants. The General Contractor shall be responsible for final cleaning.

5 PAGES

SUBMITTAL ITEM 5 AND 6





1/4 SCALE

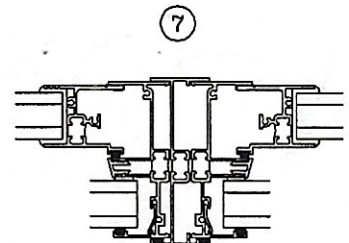
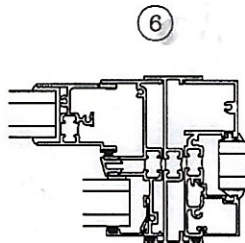
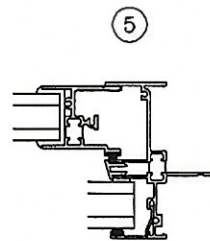
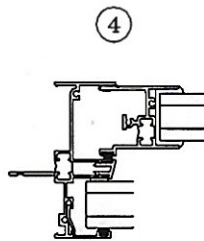
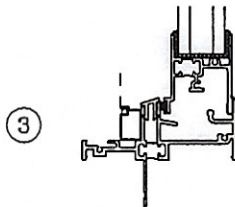
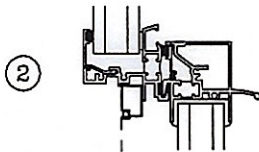
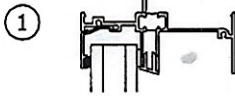
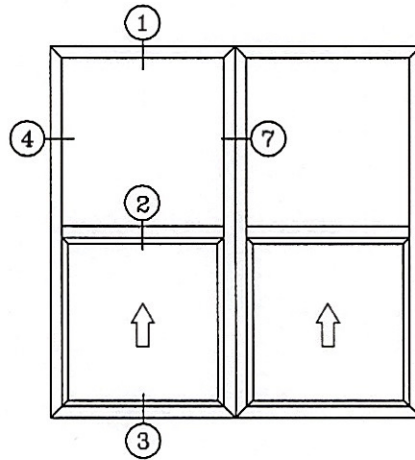
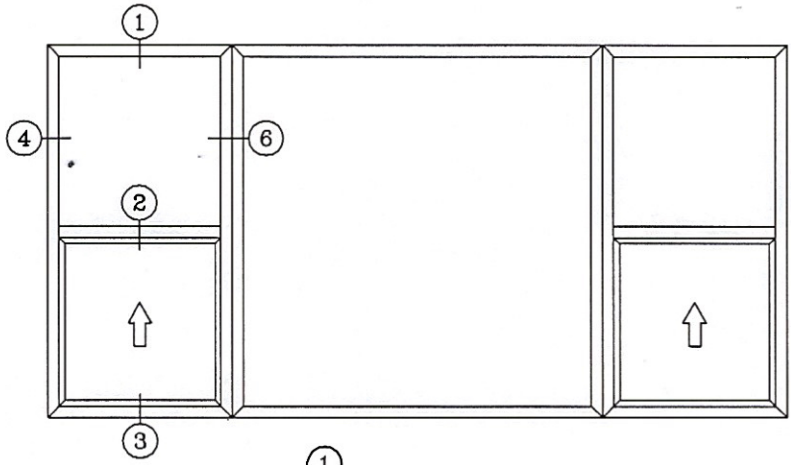
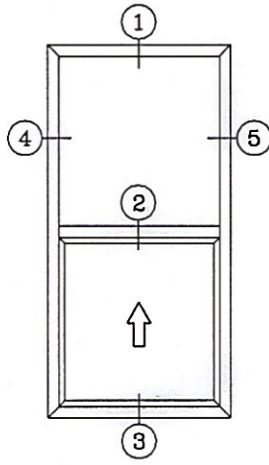

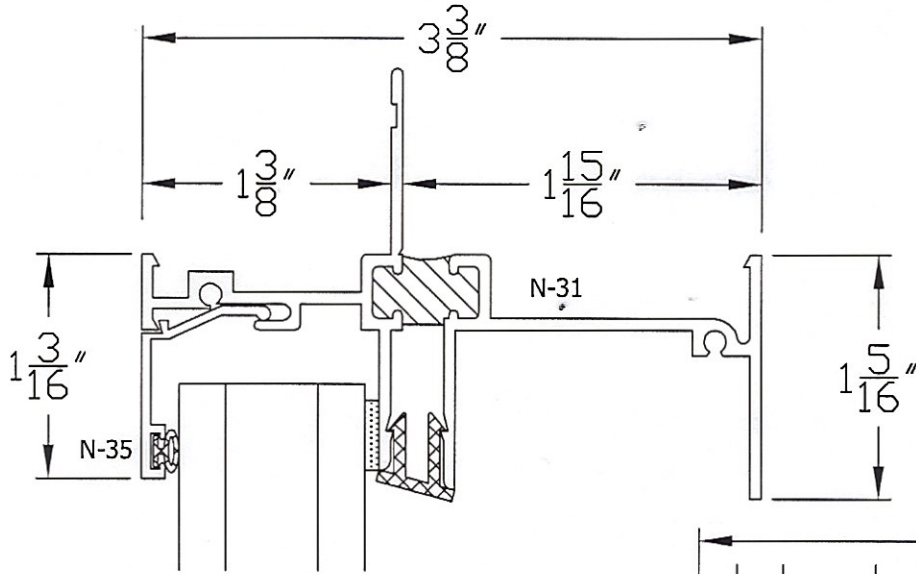

① HEAD

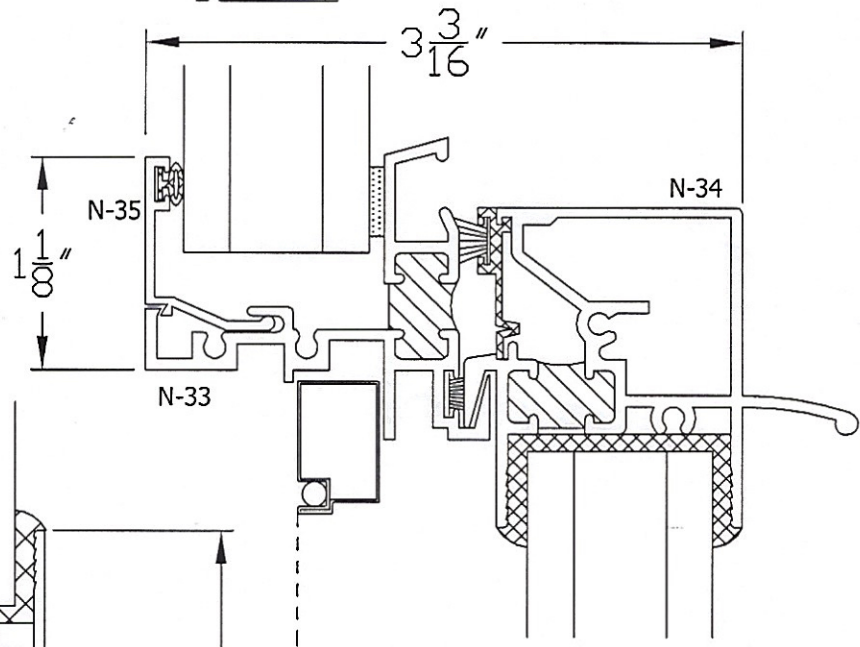

② INTERLOCK

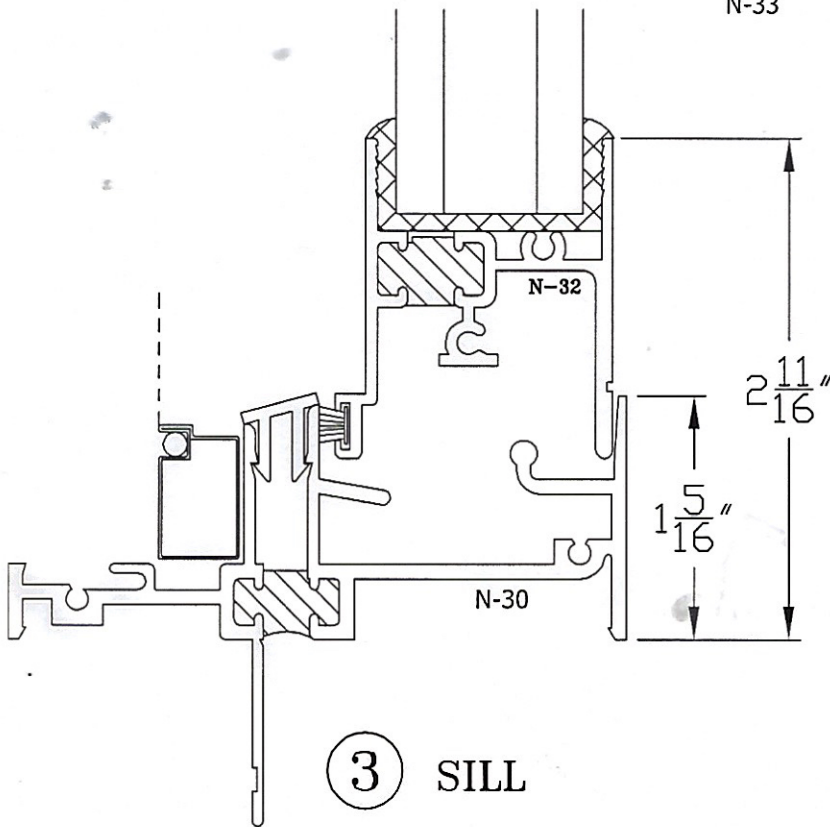

③ SILL



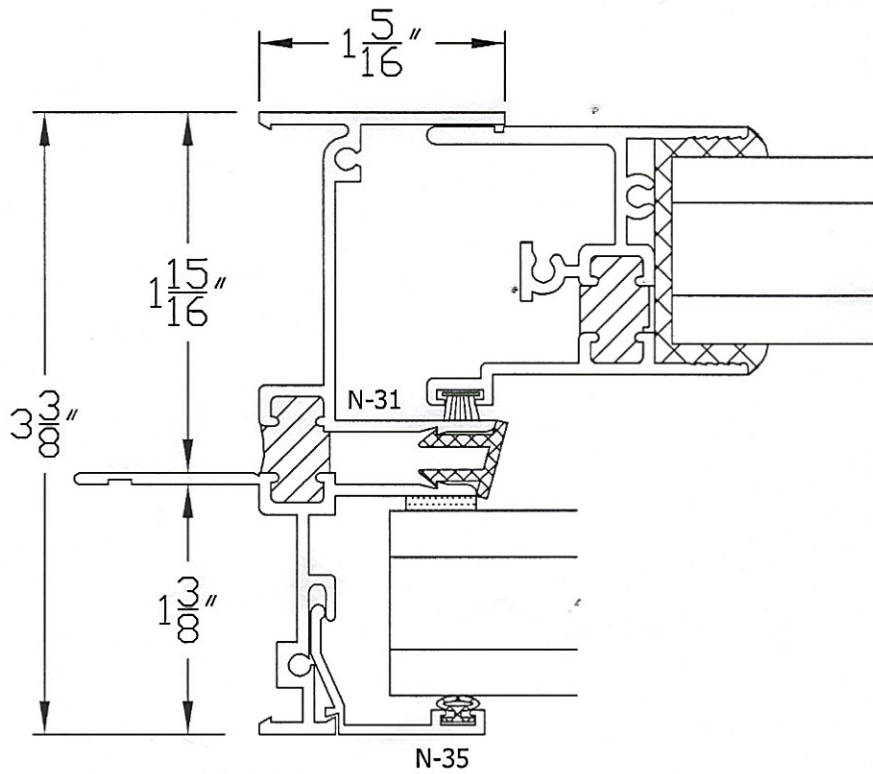

④ LEFT JAMB

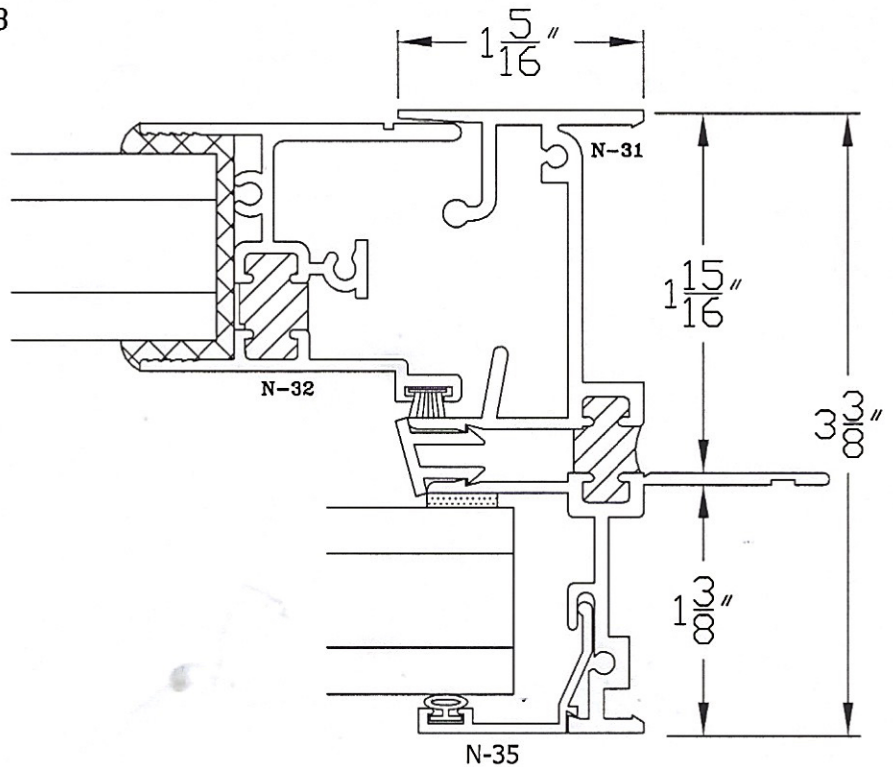

⑤ RIGHT JAMB

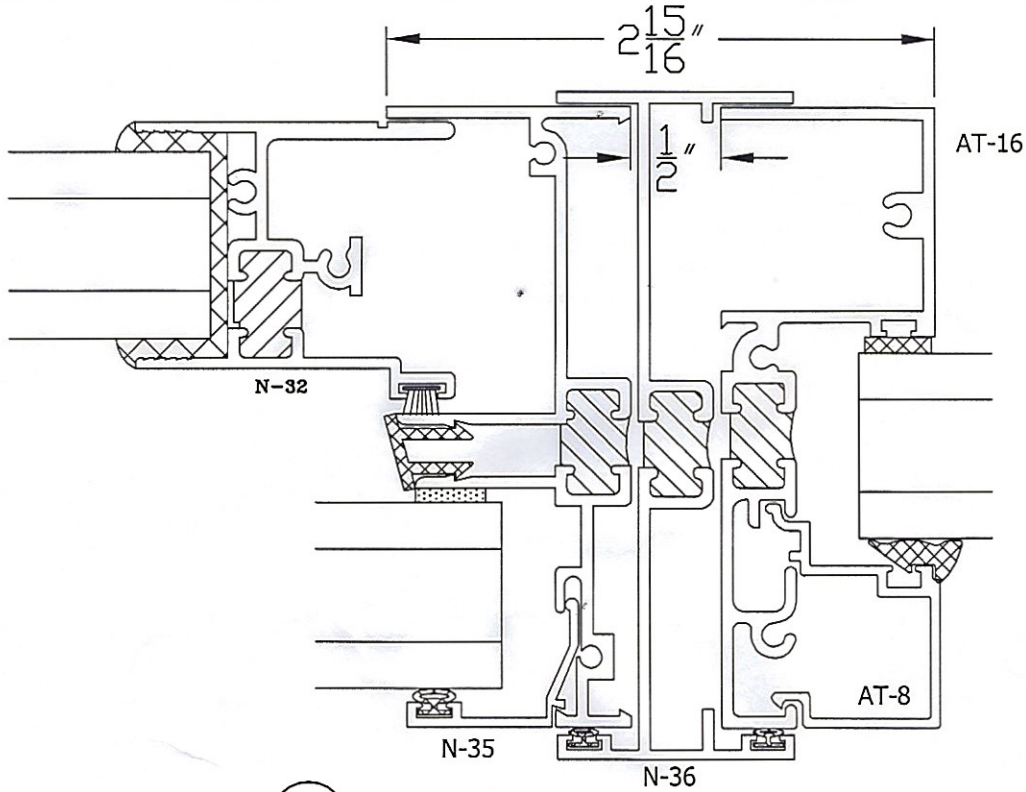

⑥ STACK BAR W/FIXED @ RIGHT

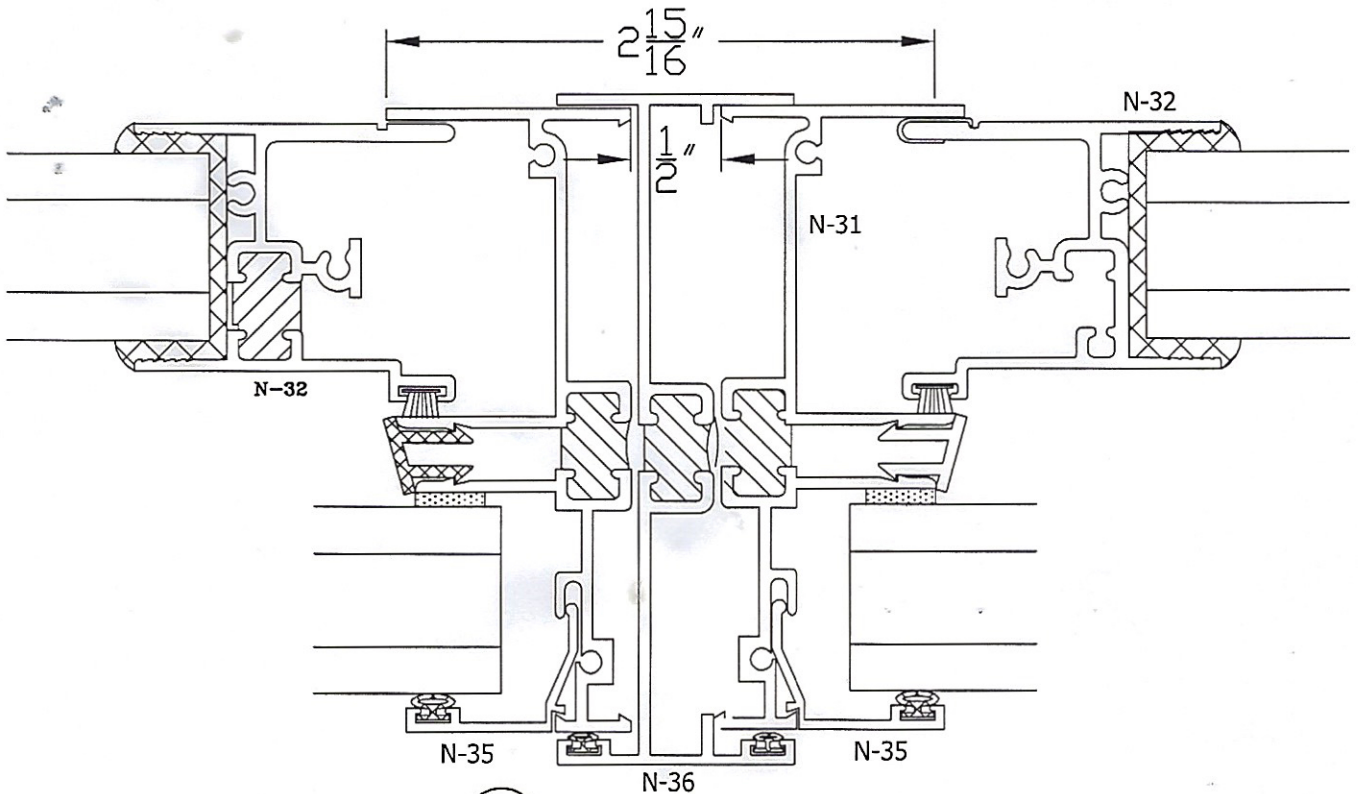

⑦ STACK BAR