

**Stormwater Site Plan
Puget Sound Energy
Operational Training Center
325 Todd Road NW
Puyallup, Washington**

Tax Parcel Numbers:
04202-11030

Prepared For:

Zervas Group Architects
209 Prospect Street
Bellingham, WA 98225
(360) 734-4744

Prepared By:

Freeland & Associates, Inc.
2500 Elm Street, Suite 1
Bellingham, WA 98225
(360) 650-1408



December 2023

Table of Contents

ENGINEER'S DECLARATION	4
STORMWATER SITE PLAN	5
Existing Conditions Summary.....	5
Critical Areas.....	6
Project Overview	7
Onsite Soils Analysis.....	8
Onsite Soils Testing	8
Offsite Analysis	9
Receiving Water Analysis.....	10
DOE AND CITY OF PUYALLUP MINIMUM REQUIREMENTS	11
Minimum Requirement #1 - Preparation of Stormwater Site Plans ("SSP")	12
Minimum Requirement #2 - Construction Stormwater Pollution Prevention Plan (SWPPP)	12
Minimum Requirement #3 - Source Control of Pollution	12
Minimum Requirement #4 - Preservation of Natural Drainage Systems and Outfalls.....	13
Minimum Requirement #5 - On-site Stormwater Management	13
Minimum Requirement #6 - Runoff Treatment.....	17
Minimum Requirement #7 - Flow Control	17
Minimum Requirement #8 - Wetlands Protection.....	17
Minimum Requirement #9 - Operation & Maintenance	18
FIGURES.....	19
Figure 1 - Vicinity Map.....	20
Figure 2 - Aerial Photograph	21
Figure 3a - Soil Map.....	22
Figure 3b - Soil Map.....	23
Figure 3c - Soil Map	24
Figure 4 - Downstream Drainage Map.....	25
Figure 5 - Water Quality Assessment Map	26
Figure 6 - 2019 DOE Minimum Requirements	27
Figure 7 - Post-development Basin Map.....	28
Figure 8 - Stormwater Treatment Basin Map.....	29
Figure 9 - DOE Wetland Protection On-Site Wetland	30
Figure 10 - DOE Wetland Protection Off-Site Wetland	31



Figure 11 – Pre-development Off-Site Wetland Basin	32
Figure 12 – Post-development Off-Site Wetland Basin	33
CALCULATIONS.....	34
Stormwater Modeling Overview.....	35
Existing Conditions (Predevelopment).....	37
Proposed Conditions (Post-developed)	38
Stormwater Modeling Input & Output - Flow Control Calculations.....	39
BMP T7.30 – Bioretention	44
Stormwater Modeling Input & Output – Bioretention Treatment Calculations.....	44
Emergency Overflow Conveyance Capacity.....	49
Wetland Hydroperiod Analysis	52
APPENDIX	55
Geotechnical Evaluation.....	56
Wetland Report	57
WWHM2012 Project Reports	58
Impervious Surface Table	88



ENGINEER'S DECLARATION

"I, Miles McEathron, a Professional Engineer registered in the State of Washington as a Civil Engineer, do hereby declare that the Puget Sound Energy Operational Training Center Stormwater Site Plan dated December 2023 was prepared by, or under my personal supervision, and that said Report was prepared in accordance with generally accepted engineering practices. I hereby affirm that, to the best of my knowledge, information and belief, subject Report was prepared in full compliance with the 2019 Washington State Department of Ecology Stormwater Management Manual for Western Washington (2019 DOE SWMM), City of Puyallup Municipal Code 21.10.040, and all Technical Standards adopted there under.



Miles McEathron
WA P.E. #49494

This report is not intended to be a final site plan for this project or any individual proposed improvements, and is not intended for use as part of any review of critical area. Existing drainage and site conditions or improvements not mentioned are beyond the scope of this report.

STORMWATER SITE PLAN

The Stormwater Site Plan (SSP) is the comprehensive report containing all of the technical information and analysis necessary for regulatory agencies to evaluate the proposed development for compliance with stormwater requirements.

Existing Conditions Summary

The project site is located at 325 Todd Road NW, Puyallup, WA 98231. The site is one tax parcel (Tax Parcel Number 04202-11030) which totals approximately 6.17 acres of land and forms a triangular shape. The subject parcel is owned by Puget Sound Energy, Inc. The site is bordered by Todd Road NW to the south, 4th Street NW to the west and Union Pacific Railroad to the northeast. State Route 161 lies east of the site. Refer to *Figure 1 – Vicinity Map* for the project location.

The City of Puyallup Comprehensive Plan designation of the site is Light Manufacturing/Warehousing (LM/W). The City of Puyallup zoning designation of the site is Limited Manufacturing (ML). Adjacent land uses vary and include single-family residential (north), product distribution centers (south/southeast), and vacant land (west).

Much of the east half of the site is surfaced with gravel and used as an equipment storage yard for PSE vehicles, materials, and equipment. Two gated driveway entrances access the gravel yard from Todd Road NW. For security purposes, the gravel yard is lined with barbed wire fencing. Vegetation in the east half of the parcel consists of evergreen trees, shrubbery, and perimeter grass. The western half of the site is undeveloped and vegetated with grasses and scattered trees. Overall site topography is generally flat. Refer to *Figure 2 – Aerial Photograph* for the existing site conditions.

The site is within North Puyallup basin on City of Puyallup drainage basin mapping. However, based on correspondence with City staff, there is a basin boundary between Wapato Creek and Puyallup River which appears to generally follow the north edge of Todd Road NW. Rainwater landing on Todd Road NW sheet flows to the gutter pan on the south side of the road for collection in catch basins. Runoff routed through the conveyance system on the south side of Todd Road NW is pumped to a regional stormwater management facility located at N Meridian and Spencer Road. From this pond, runoff ultimately leads to Puyallup River. Rainwater landing north of Todd

Road NW roadway surface will sheet flow to a separate storm drain conveyance system on the north side of the roadway. Runoff routed through the conveyance system on the north side of Todd Road NW is directed west in a ditch and culvert system to Wapato Creek, approximately 650 lineal feet away.

See *Offsite Analysis* section of this report for further description of the existing drainage system downstream from the project.

Critical Areas

A wetland exists on the western edge of the project limits adjacent to 4th Street NW. Per the Wetland, Stream, and Fish and Wildlife Habitat Assessment prepared by Soundview Consultants, LLC (dated April 2023), the wetland has no buffer or mitigation required for wetland impacts. The wetland will be protected during construction and remain in place. Unmapped off-site wetlands exist to the west of the project site across 4th Street NW.

The site is located within a critical aquifer recharge area. These areas have a critical recharging effect on groundwater and are essential for maintaining public water supplies. To protect groundwater, stormwater runoff from pollution generating surfaces will be treated using bioretention cells prior to exposing runoff to native soils for infiltration. Infiltration has been deemed infeasible on a large-scale basis, however, exposure to native soils for infiltration will be provided to the maximum extent feasible. Based on a Critical Aquifer Recharge Areas Evaluation prepared by Terra Associates, Inc. (dated June 2023), the planned site development will not result in significant adverse impacts to the water quality or recharge of the aquifer. In addition, the on-site water quality and discharge to existing storm system would adequately mitigate any potential adverse impacts to the current on-site groundwater recharge and support of downgradient surface water features and wetlands.

According to Pierce County PublicGIS, the site is not located in floodways or regulated floodplains. City of Puyallup – Critical Areas App shows no flooding hazards within the property. The site is within a volcanic hazard area as shown on USGS Mount Rainier Lahar Hazard Map, dated November 9, 2016. In addition, the site is mapped as having a high susceptibility to soil liquefaction as shown on the Washington Department of Natural Resources Natural Hazards Single-Topic Map. Refer to the project's geotechnical report for additional information.

Project Overview

Project improvements consist of a new operational training facility (OTC) to support Puget Sound Energy. Approximately 34,000 square feet in size, the primary OTC building will be constructed in the central region of the site. The proposed building will contain a combination of offices, laboratories, storage, mechanical, and instructional spaces. An outdoor training space with field areas, work-related structures, enclosed spaces, and covered areas will be located to the west of the proposed building. Parking for employees and visitors will be located to the east of the proposed building. Associated improvements include fencing, utility extensions and connections, and stormwater management facilities.

Frontage improvements will be provided along Todd Road NW including curb, gutter, planter strip and sidewalk. A right-of-way dedication will be necessary along Todd Road NW. As part of this project an Alternate Methods Request (AMR) will propose no improvements to 4th Street NW. Per correspondence with City staff, if no access is proposed to 4th Street NW from the project site then frontage improvements will not be necessary along 4th Street NW. Access to the site will be provided through two driveways entrances on Todd Road NW.

Stormwater will be managed on site with a detention pond east of the parking lot. On-site pollution generating surfaces will be conveyed to bioretention cells for stormwater treatment prior to detention.

Stormwater dispersion and infiltration systems were analyzed for use with this project. Full dispersion of stormwater runoff is not feasible due to limited area for flow path lengths. Per geotechnical analysis, infiltration should not be relied on to manage stormwater runoff on a whole scale basis due to shallow groundwater and fine-grained soils. Even though infiltration is infeasible, the design will maximize stormwater contact with the ground and promote the potential for infiltration to the maximum extent feasible. Refer to *Minimum Requirement #6 Runoff Treatment* and *Minimum Requirement #7 Flow Control* within this report for further discussion about the applicable stormwater management requirements and the *Calculations* section for the specific design of the facilities.



Onsite Soils Analysis

According to the Natural Resource Conservation System Online Soil Survey (NRCS), soils on site are mapped as a combination of Sultan silt loam, Puyallup fine sandy loam, and Pilchuck fine sand.

Soil horizons, consisting of these soil types, is typically deposited by alluvial processed in the form of floodplains and derived from alluvium deposited by the Puyallup River. The Sultan series is classified as hydrologic group 'C/D' which consists of soils with low infiltration rates and high runoff potential when thoroughly wetted. The Puyallup and Pilchuck series are classified as hydrologic group 'A' which includes soils with high infiltration rates and low runoff potential when thoroughly wetted. Refer to *Figure 3a-c Soils Map* for the regional soil mapping.

Onsite Soils Testing

A geotechnical evaluation of the site was conducted by Terra Associates Inc. in November 2022. The purpose of the evaluation was to identify soil and groundwater conditions, geologic hazards, and provide geotechnical recommendations related to site preparation and grading.

During the field assessment, thirteen (13) test borings were advanced to depths ranging from approximately 10 to 30 feet below existing site grades. Subsurface conditions generally consisted of native alluvial sediments composed of alternating and interbedded layers of soft to stiff silt to clayey silt, and very loose to medium dense sand to silty sand. The site is underlain by a regional groundwater table residing in the alluvial sediments. Groundwater was encountered at depths of approximately 4.5 feet below existing grades in the western portion of the site and 10 feet below existing grades in the eastern portion of the site at the time of soil exploration in November, 2022. Two groundwater monitoring wells were installed in the east portion of the site from December 2022 through March 2023. Seasonal high groundwater was recorded at a depth of 7.2 feet below ground surface (groundwater elevation of 39) at Boring B-13 and a depth of 8 feet below ground surface (groundwater elevation of 38.8) at Boring B11.

The geotechnical consultant concluded infiltration is not feasible to manage stormwater runoff on a whole scale basis due to shallow groundwater and fine-grained silt soils. A copy of the complete Terra Associates report dated December 2022 and subsequent memorandums are provided in the *Appendix* section of this SSP for reference.



Offsite Analysis

Runoff discharged from the proposed stormwater management facility will connect to the municipal storm system at a catch basin in the intersection of Todd Road NW and 4th Street NW. A 12-inch storm drain line will route runoff west for outfall to Todd Road NW roadside ditch. The roadside ditch routes runoff approximately 500 lineal feet west for discharge to Wapato Creek.

Downstream from the project site, the entire drainage system is owned and maintained by the City of Puyallup. Using topographic maps, City of Puyallup Stormwater System Mapping, field investigation, and the City of Puyallup Comprehensive Stormwater Plan, no erosion or flooding problems have been identified within 1/4 mile from the project site. Based on correspondence with City of Puyallup staff, there are no reports of flooding in the vicinity. However, staff did note issues due to groundwater and elevation challenges. Existing issues due to groundwater or elevation challenges are not anticipated to be aggravated due to the project because flow rates leaving the site will be reduced.

The proposed project will provide stormwater flow control and is not anticipated to affect capacity of existing conveyance systems downstream from the site under normal mitigated working conditions. In the event an overflow from the stormwater facility does occur, there will be an overflow structure directing runoff to drainage structures in Todd Road NW. If stormwater spills out from drainage structures, runoff will flow over stabilized surfaces into Todd Road NW roadside gutter pan. Overflow runoff will travel west toward the existing downstream roadside ditch.



Receiving Water Analysis

Stormwater runoff from the project site drains to Wapato Creek. Wapato Creek is listed as an impaired water body in Department of Ecology's Water Quality Assessment 303(d) list for Washington. According to the department's online Assessment tool, Wapato Creek is listed for Bacteria (category 5), and Dissolved Oxygen (category 5). See Table 1 below for the full list of impairments and *Figure 5 - Water Quality Assessment Map* for additional information.

Table 1 DOE Water Quality Assessment				
Name	Parameter	Medium	Category	Assessment ID
Wapato Creek	Bacteria	Water	5	17110019020852
Wapato Creek	Dissolved Oxygen	Water	5	17110019020852

Proposed commercial development as part of this project is not expected to create new pollutant sources as all pollution generating surfaces will be subject to enhanced stormwater treatment.. No sources of bacteria are known to exist on site or are proposed, and the project will include a connection to the municipal sewer system. Furthermore, chemicals for grounds and landscape maintenance, including detergents, cleaning products, and fertilizers will be stored indoors to prevent contact with stormwater.



DOE AND CITY OF PUYALLUP MINIMUM REQUIREMENTS

Minimum stormwater management requirements for this project have been determined using Puyallup Municipal Code 21.10.040 and the 2019 Department of Ecology Stormwater Management Manual for Western Washington (2019 DOE SWMM or DOE Manual). With more than 5,000 square feet new plus replaced hard surface area, the project is subject to Minimum Requirements 1 through 9.

MINIMUM REQUIREMENT SUMMARY NEW DEVELOPMENT					
Minimum Requirement		Not Applicable	Variance Requested	Standard Requirements Incorporated	Comments (Report Section Reference or BMP Identifier)
#	Description				
1	Preparation of Stormwater Site Plans			✓	
2	Construction Stormwater Pollution Prevention Plan			✓	See "Additional Comments"
3	Source Control of Pollution			✓	
4	Preservation of Natural Drainage Systems and Outfalls			✓	
5	On-Site Stormwater Management			✓	
6	Runoff Treatment			✓	
7	Flow Control			✓	
8	Wetlands Protection			✓	
9	Operation and Maintenance			✓	
#	Additional Comments				
2	The Construction SWPPP is included in the civil construction drawings.				

Minimum Requirement #1 - Preparation of Stormwater Site Plans (“SSP”)

This report serves as a Stormwater Site Plan (SSP). All stormwater management systems have been designed according to Department of Ecology (DOE) and City of Puyallup standards.

Minimum Requirement #2 - Construction Stormwater Pollution Prevention Plan (SWPPP)

A SWPPP has been prepared as a separate document. Each of the thirteen elements of a SWPPP must be considered and included in a Construction SWPPP unless site conditions render the element unnecessary and the exemption from that element is clearly justified in the narrative of the SWPPP. The SWPPP shall include, at a minimum, the narrative and copies of Best Management Practice detail sheets that will be utilized as a part of the SWPPP.

During construction, the contractor shall maintain a copy of the SWPPP on site and shall update or modify the SWPPP as necessary for the current conditions on site. The contractor's schedule and available crew, equipment, and materials will be determined after the project is submitted for permits, but prior to the start of construction. Accordingly, some BMPs that have been specified may not be necessary, while other additional BMPs may be required.

This project will disturb more than one acre of soil and will require a Construction General Stormwater NPDES permit from Washington State Department of Ecology. As such, the project shall retain a Certified Erosion and Sediment Control Lead (CESCL) to determine which BMPs are necessary as site conditions change during construction. The contractor and/or CESCL shall add any BMP specifications that have not already been included in the SWPPP prepared by Freeland & Associates, Inc.

Minimum Requirement #3 - Source Control of Pollution

Pollutant sources for commercial projects include vehicular traffic, fertilizers, and other detergents or chemicals typical to building maintenance activities. Pollution will be controlled at the source to the maximum extent possible. All known, available and reasonable source control BMPs have been applied to the design and layout of the site and stormwater plans.

Vehicular traffic is anticipated to be a primary source of potential pollutants. Parking for the project will be located outside of the proposed building footprints and any stormwater runoff from this area will receive stormwater treatment prior to discharge.

Secondary sources of pollutants include garbage and recycling enclosures and landscape areas. Garbage and recycling will be collected in individual covered bins in an enclosure with a roof. The garbage enclosure will drain to sanitary sewer as required by City of Puyallup. To minimize landscaping maintenance and to reduce potential erosion, BMP T5.13 will be applied to all landscaped areas to promote healthy plants and appropriate groundcover.

Minimum Requirement #4 - Preservation of Natural Drainage Systems and Outfalls

The entire project site is contained within the Wapato Creek drainage basin. No stormwater diversions are proposed as a part of this project. Drainage patterns will be maintained by collecting stormwater which will then drain to the municipal storm drain system. The outfall of the municipal storm drain system outfalls to Wapato Creek which appears to ultimately outfall to Commencement Bay.

Minimum Requirement #5 - On-site Stormwater Management

"Projects shall employ On-site Stormwater Management BMPs to infiltrate, disperse, and retain stormwater runoff onsite to the maximum extent feasible without causing flooding or erosion impacts. On-site Stormwater Management BMPs shall be designed and provided in accordance with the Ecology Manual."

As a project triggering Minimum Requirements #1 through #9, and a project that is inside City of Puyallup Urban Growth Area (UGA), this project may use On-site Stormwater Management BMPs from List #2 for all surfaces within each type of surface in List #2 or demonstrate compliance with LID Performance Standards. This project will meet the requirements outlined in List #2 to the maximum extent feasible.

Projects choosing to utilize List #2 of the 2019 DOE Manual to meet requirements for Minimum Requirement #5 - On-site Stormwater Management must consider the BMPs in the order listed for each type of surface. The first BMP that is considered feasible must be used on the site. No other On-site Stormwater Management BMPs are necessary for that surface. The following table identifies all required BMPs in List #2 and if they are feasible or infeasible. Separate tables have been provided for on-site and off-site analysis as requested by City of Puyallup.



TABLE 3a - MINIMUM REQUIREMENT #5: LIST #2

ON-SITE ANALYSIS

	Minimum Requirement	Feasible	Infeasible	Criteria Comments
#	Lawn & Landscaped Area			
1	Post-Construction Soil Quality and Depth - BMP T5.13	✓		This BMP will be applied to all areas outside of roofs or hard surfaces disturbed during construction.
#	Roofs			
1	Full Dispersion - BMP T5.30 Full Infiltration - BMP T5.10A		✓	<p>Full Dispersion: Infeasible due to impervious coverage and insufficient flow path length due to proximity to property lines from impervious surfaces.</p> <p>Full Infiltration: Infiltration trenches per the DOE Manual shall be 100 lineal foot maximum trench length with 6 feet separation between trenches. This site does not provide enough footprint area due to setbacks, utilities, planting islands (with silva cells), shallow groundwater and poorly draining soils to infiltrate the roof area. In addition, the DOE Manual states that silt soils have a hydraulic conductivity that is too small for adequate infiltration and are infeasible for downspout trenches.</p>
2	Bioretention – BMP T5.70		✓	Infeasible due to native soil infiltration rates less than 0.3 inches per hour per DOE Manual.
3	Downspout Dispersion BMP T5.10B		✓	Infeasible due to impervious coverage and insufficient flow path length due to proximity to property lines from impervious surfaces. One location in the northwest corner of the property does have proper flow path length, however, this location is approximately 250 feet from the roof area and would require complicated routing through the outdoor training area of the site to reach. In addition, there is a bioretention cell along the west perimeter of the outdoor training area that conflicts with routing storm drains through.
4	Perforated Stub-out Connection BMP T5.10C		✓	Per DOE Manual perforated stub outs are to be located between roof downspouts and a stub out to the local drainage system. This BMP is not intended for sites that need to meet Minimum Requirement #7. All runoff needs to be routed to the flow control



				system prior to discharge to the local drainage system.
#	Other Hard Surfaces			
1	Full Dispersion BMP T5.30		✓	Infeasible due to impervious coverage and insufficient flow path length due to proximity to property lines from impervious surfaces.
2	Permeable Pavement - BMP T5.15		✓	Infeasible due to native soil infiltration rates less than 0.3 inches per hour per DOE Manual. In addition, a large portion of the site is covered with existing gravel. Per the DOE Manual permeable pavement is infeasible where replacing existing impervious surfaces.
3	Bioretention – BMP T5.70		✓	Infeasible due to native soil infiltration rates less than 0.3 inches per hour per DOE Manual.
4	Sheet Flow Dispersion BMP T5.12 Concentrated Flow Dispersion BMP T5.11		✓	Infeasible due to impervious coverage and insufficient flow path length due to proximity to property lines from impervious surfaces.

As noted previously in this report, stormwater dispersion and infiltration systems were analyzed for use with this project. Fully dispersing stormwater runoff from on-site improvements is infeasible due to a large quantity of proposed impervious surfaces and limited flow dispersion pathways. Infiltration potential of the site was also considered; however, poorly draining soils and high groundwater render infiltration infeasible. Stormwater from the development will be managed with a stormwater flow control pond and bioretention cells for treatment. This design will maximize stormwater contact with the ground and promote the potential for infiltration to the maximum extent feasible. Outfall for the stormwater detention system will be the City of Puyallup municipal storm system.

TABLE 3b - MINIMUM REQUIREMENT #5: LIST #2				
OFF-SITE ANALYSIS				
Minimum Requirement		Feasible	Infeasible	Criteria Comments
#	Lawn & Landscaped Area			
1	Post-Construction Soil Quality and Depth - BMP T5.13	✓		This BMP will be applied to all areas outside of roofs or hard surfaces disturbed during construction.
#	Roofs			
1	Full Dispersion - BMP T5.30 Full Infiltration - BMP T5.10A		✓	There are no roof areas as part of the off-site area.
2	Bioretention – BMP T5.70		✓	There are no roof areas as part of the off-site area.
3	Downspout Dispersion BMP T5.10B		✓	There are no roof areas as part of the off-site area.
4	Perforated Stub-out Connection BMP T5.10C		✓	There are no roof areas as part of the off-site area.
#	Other Hard Surfaces			
1	Full Dispersion BMP T5.30		✓	Infeasible due to insufficient flow path length. The off-site work includes planter strip and sidewalk with no suitable dispersion path.
2	Permeable Pavement - BMP T5.15		✓	Infeasible due to native soil infiltration rates less than 0.3 inches per hour per DOE Manual. In addition, a large portion of the off-site sidewalk is covered with existing gravel. Per the DOE Manual permeable pavement is infeasible where replacing existing impervious surfaces.
3	Bioretention – BMP T5.70		✓	Infeasible due to native soil infiltration rates less than 0.3 inches per hour per DOE Manual.
4	Sheet Flow Dispersion BMP T5.12 Concentrated Flow Dispersion BMP T5.11		✓	Infeasible due to insufficient flow path length. The off-site work includes planter strip and sidewalk with no suitable dispersion path.

As noted previously in this report, stormwater dispersion and infiltration systems were analyzed for use with this project. Fully dispersing stormwater runoff from off-site improvements is infeasible due to the limited flow dispersion pathway available. Infiltration potential for off-site work was also considered; however, poorly draining soils and high groundwater render infiltration infeasible. Stormwater from the off-site work will be managed with collection and conveyance to the City of Puyallup municipal storm system.

Minimum Requirement #6 - Runoff Treatment

Proposed new pollution-generating surfaces include all portions of the proposed drive lanes and parking areas within the project. These areas will create more than 5,000 square feet of pollution-generating hard surfaces (PGHS) and will require a stormwater treatment system.

Enhanced treatment will be provided for proposed on-site PGHS using bioretention cells. Refer to Stormwater Treatment – Bioretention Cells narrative in the *Calculations* section of this report for further discussion on design.

Minimum Requirement #7 - Flow Control

This project will create more than 10,000 square feet of effective impervious surface and, therefore, must provide stormwater flow control. A flow control system will be designed for flow rates leaving the site to match predevelopment conditions.

The proposed flow control system will be a stormwater pond located in the eastern portion of the project. The system will provide flow control for the project site to mimic runoff from a forested condition for all new and replaced hard surfaces and converted pervious surfaces. Outfall from the flow control system will discharge to municipal storm systems within Todd Road NW. Refer to Flow Control narrative in the *Calculations* section of this report for further discussion on volume and design of the flow control facility.

Minimum Requirement #8 - Wetlands Protection

A wetland is located on the western edge of the property. The wetland will remain in place and be protected during construction using appropriate construction BMPs. The 2019 DOE Manual flow chart for determining wetland protection level requirements was used to determine appropriate protection levels. Refer to Figure 9 for a copy of the flow chart. General protection and protection from pollutants will be provided in accordance with the DOE Manual as well as measures provided in the wetland report.

In addition to the on-site wetland, there is an unmapped off-site wetland downstream of the project site. A separate flow chart for determining wetland protection level requirements for the off-site wetland was used to determine appropriate protection levels. Assuming worst-case conditions, the flow path leads to providing general protection, protection from pollutants, and wetland hydroperiod protection (Method 2). As with the on-site wetland, general protection and protection



from pollutants will be provided using construction stormwater BMPs, avoiding physical impacts, and providing enhanced stormwater treatment prior to discharge from the site. In addition, a hydroperiod analysis following Method 2 as outlined in Volume I, Section I-C.4 of the DOE Manual has been prepared using WWHM 2012 software and is provided in the *Calculations* section of this report.

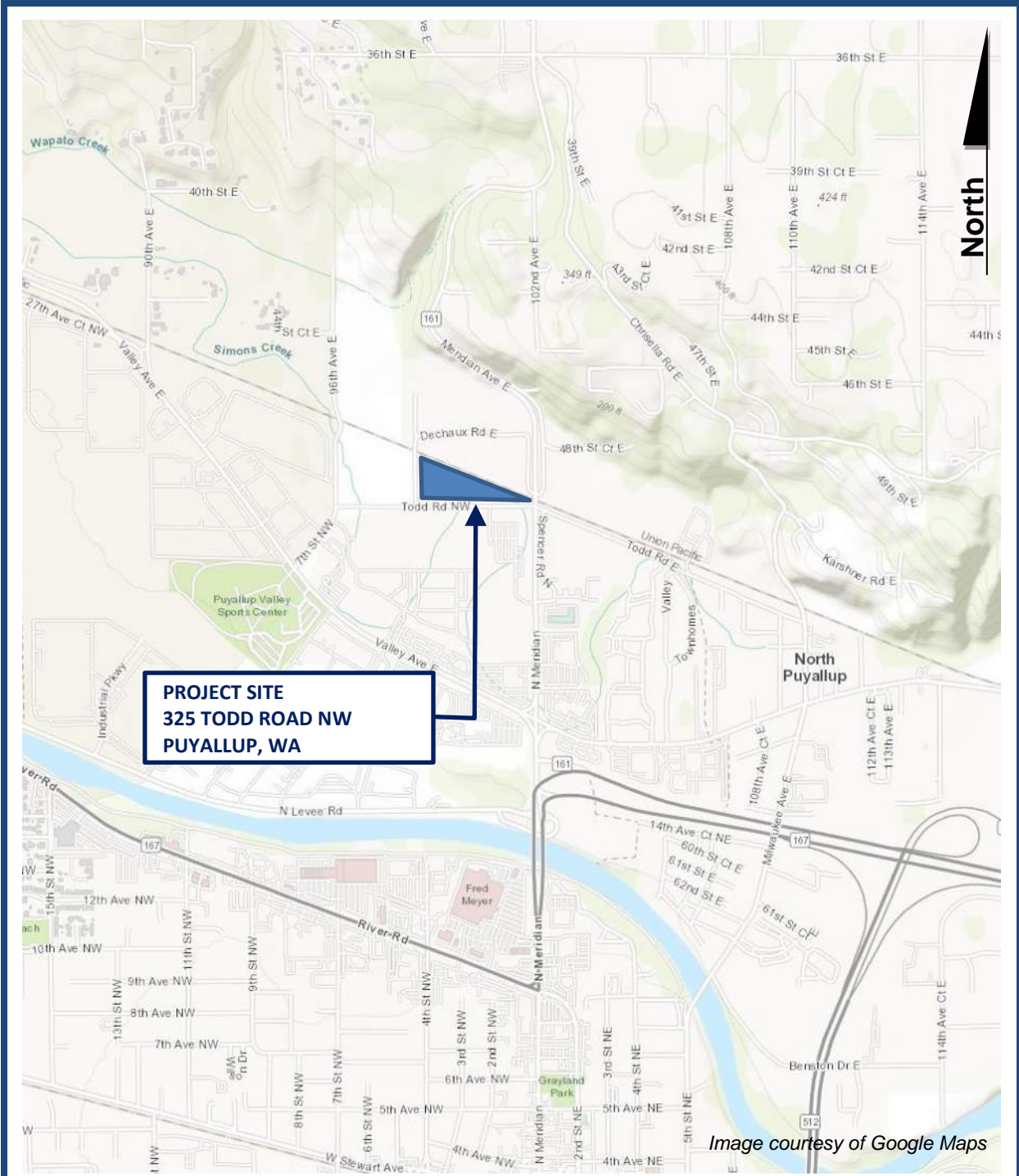
Minimum Requirement #9 - Operation & Maintenance

Proposed storm drainage improvements consist of a series of catch basins, pipes, flow control, and treatment systems. A separate operations and maintenance manual has been prepared for the proposed storm drainage improvements. The manual contains a description of the facilities, what the facilities do, and how they work. The manual also identifies and describes maintenance tasks for each component of the facilities and the required frequency of each task. Refer to the *Stormwater Operations and Maintenance Manual* prepared by Freeland & Associates, Inc. for further detail regarding maintenance tasks and frequencies.



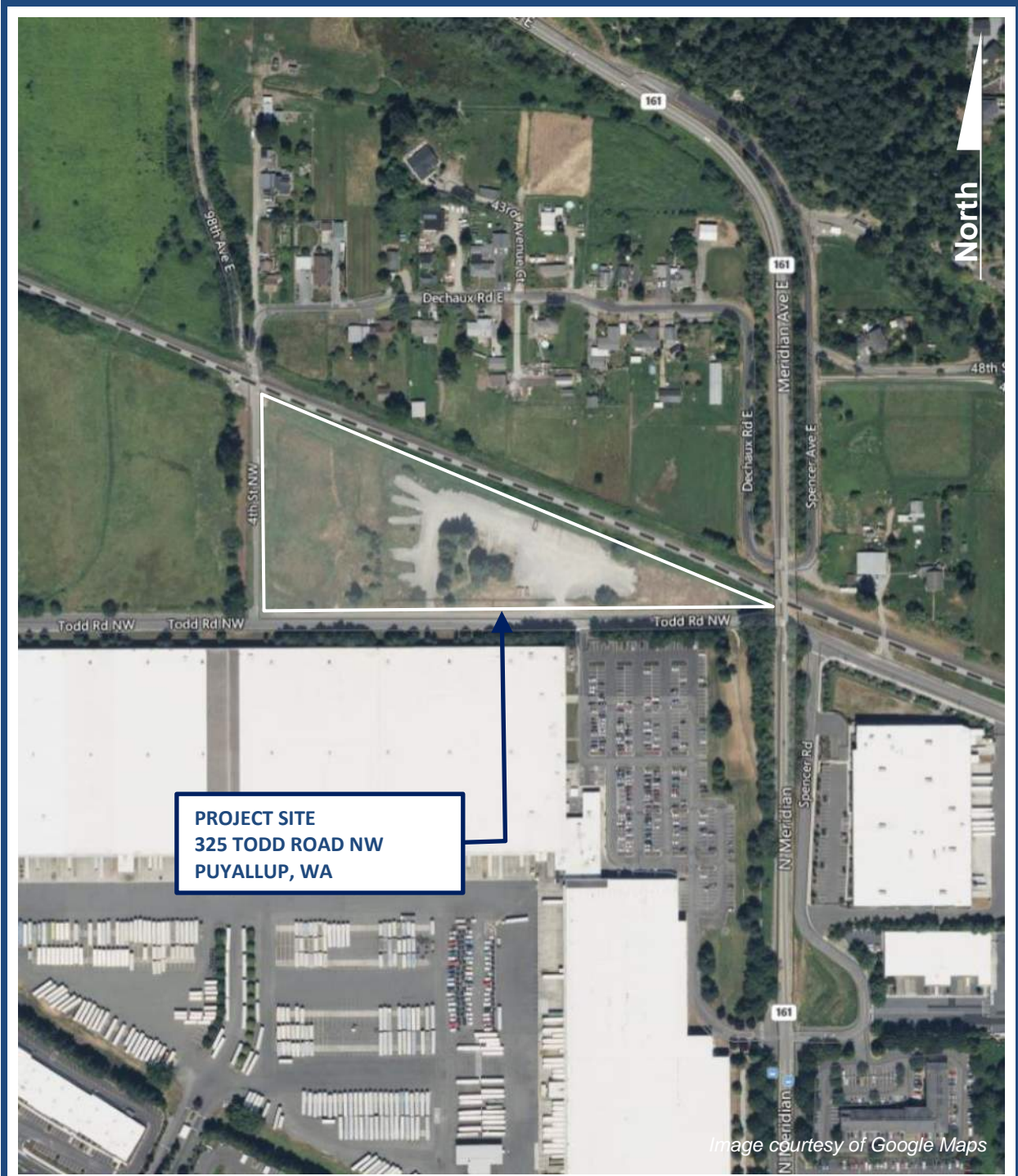
FIGURES





Vicinity Map

Fig. 1



**PROJECT SITE
325 TODD ROAD NW
PUYALLUP, WA**

Image courtesy of Google Maps



Aerial Photograph

Fig. 2





Soil Map

Fig. 3b



Soil Map

Fig. 3c

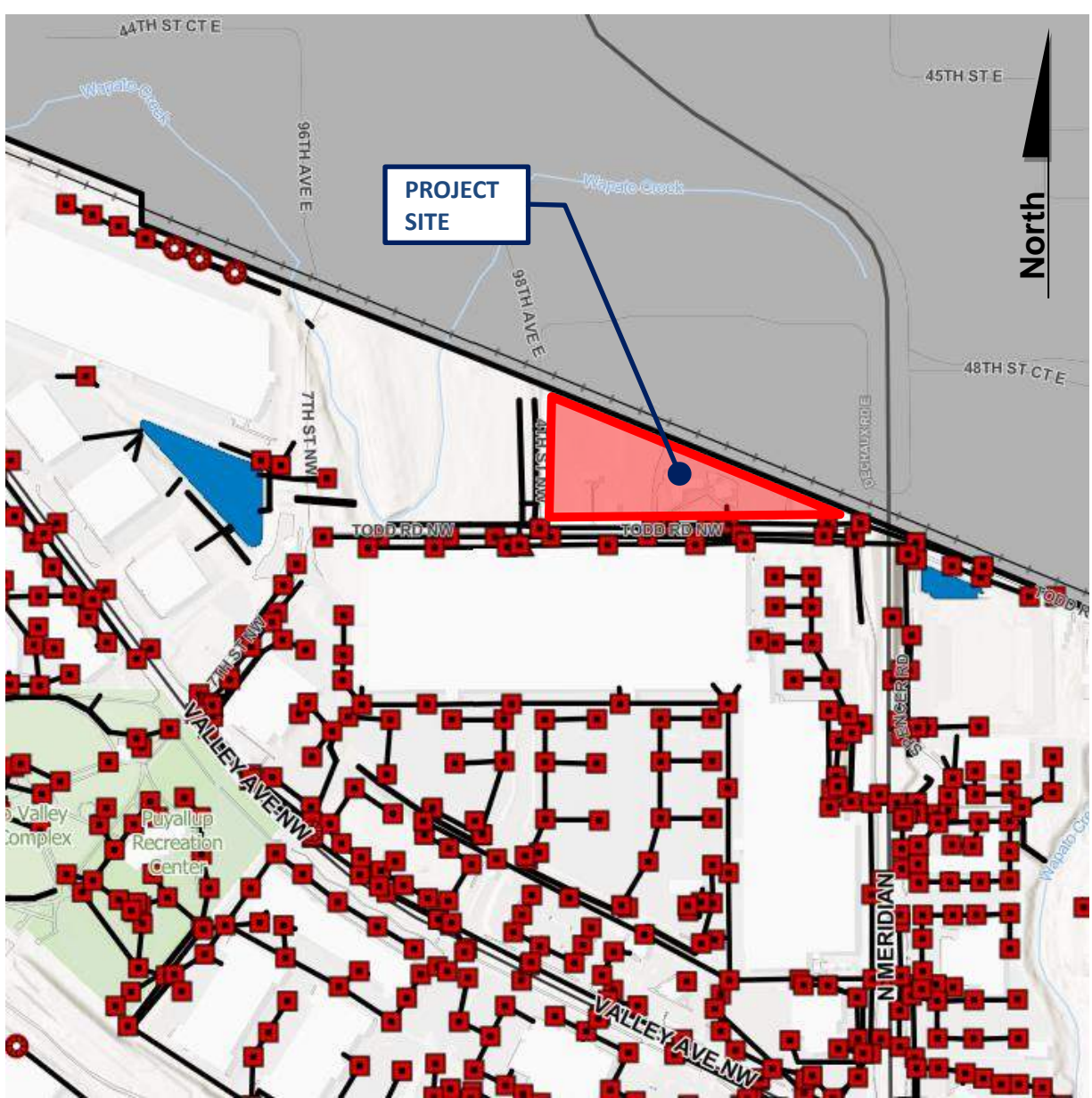


Image courtesy of City of Puyallup



Downstream Drainage Map

Figure 4

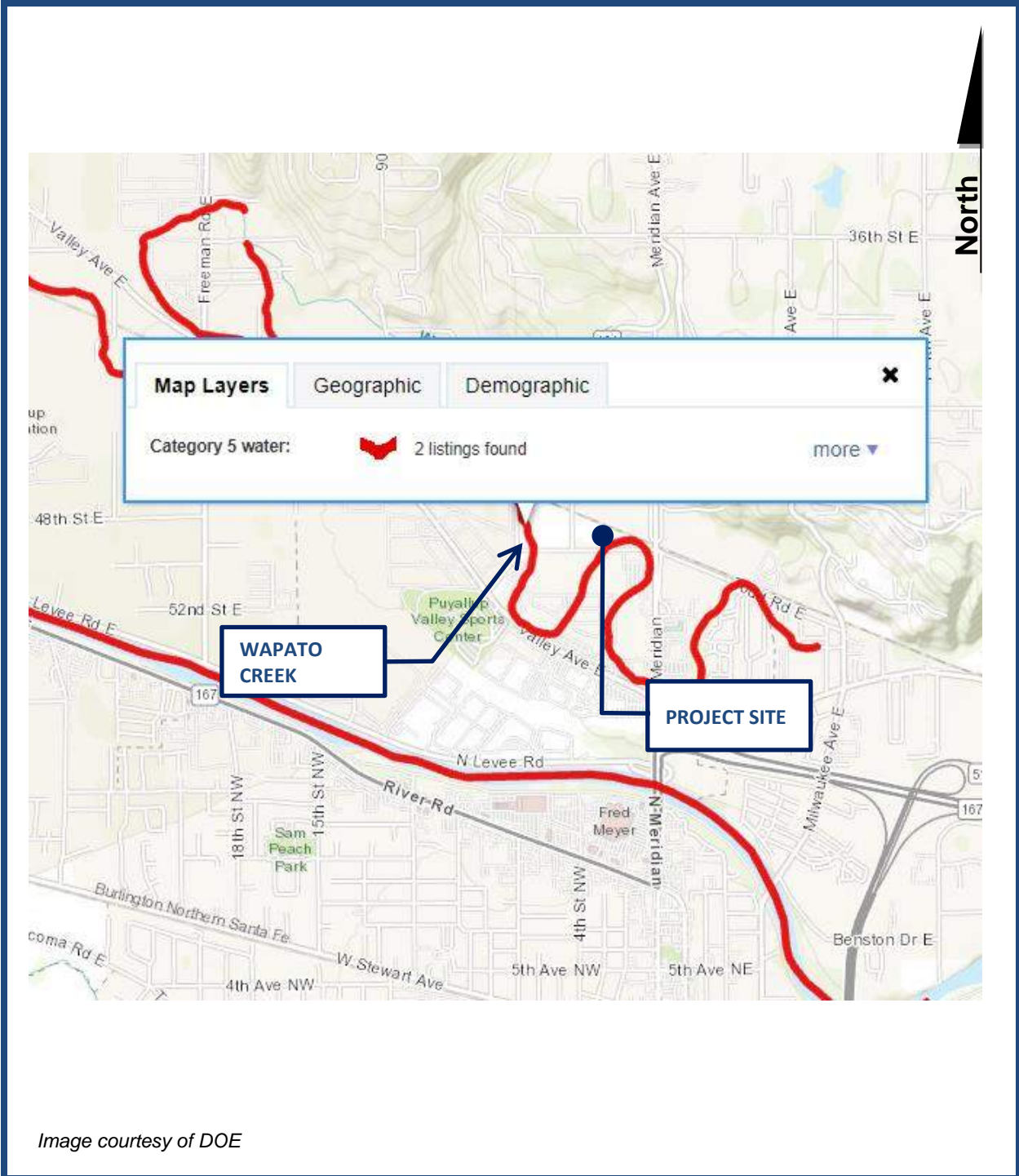
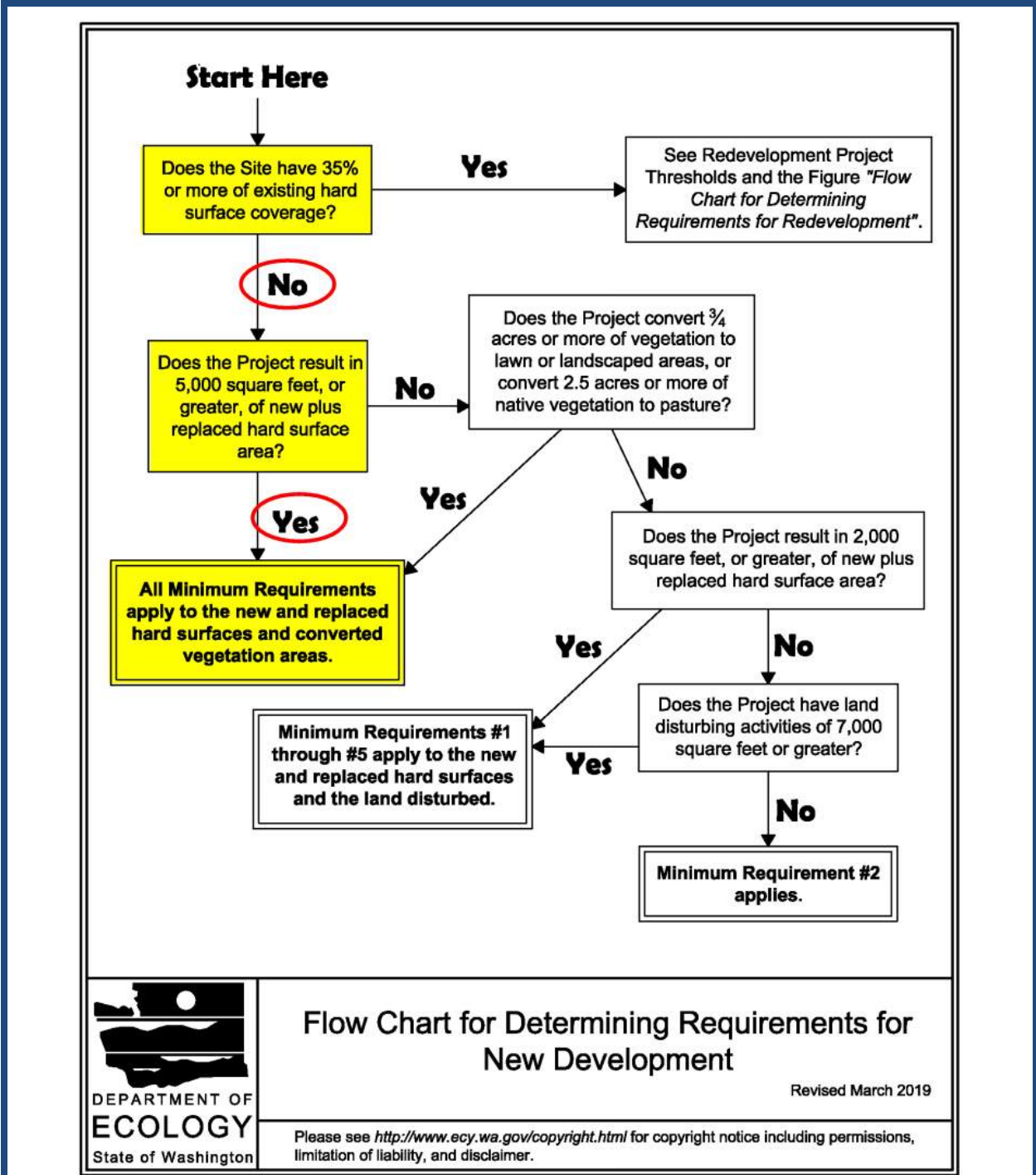


Image courtesy of DOE



Water Quality Assessment Map

Figure 5



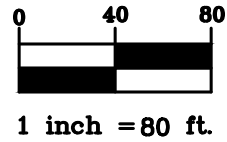
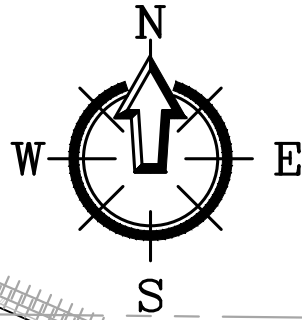
2019 DOE Minimum Requirements

Figure 6



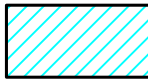
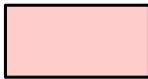
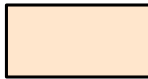
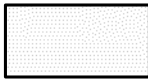


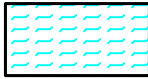


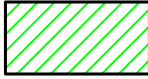
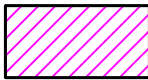
Figure 7 - Post-development Basin Map





NOTE:
VEGETATION (NOT CONVERTED) IS PROPOSED LAWN/LANDSCAPING WHERE EXISTING GRAVEL SURFACING IS LOCATED. THIS PROPOSED PERVIOUS SURFACE IS NOT CONSIDERED CONVERTED VEGETATION AND WILL NOT BE MITIGATED TO A FORESTED CONDITION. BASED ON DEPARTMENT OF ECOLOGY RECOMMENDATION THESE SURFACES ARE MODELED AS ADDITIONAL AREA INFLOW. THEY ARE CONSIDERED IMPERVIOUS IN THE PRE-DEVELOPMENT STORMWATER MODEL. ALL OTHER SURFACES (NEW HARD SURFACE AND CONVERTED VEGETATION) ARE MITIGATED TO FORESTED CONDITION.

DRAINAGE LEGEND

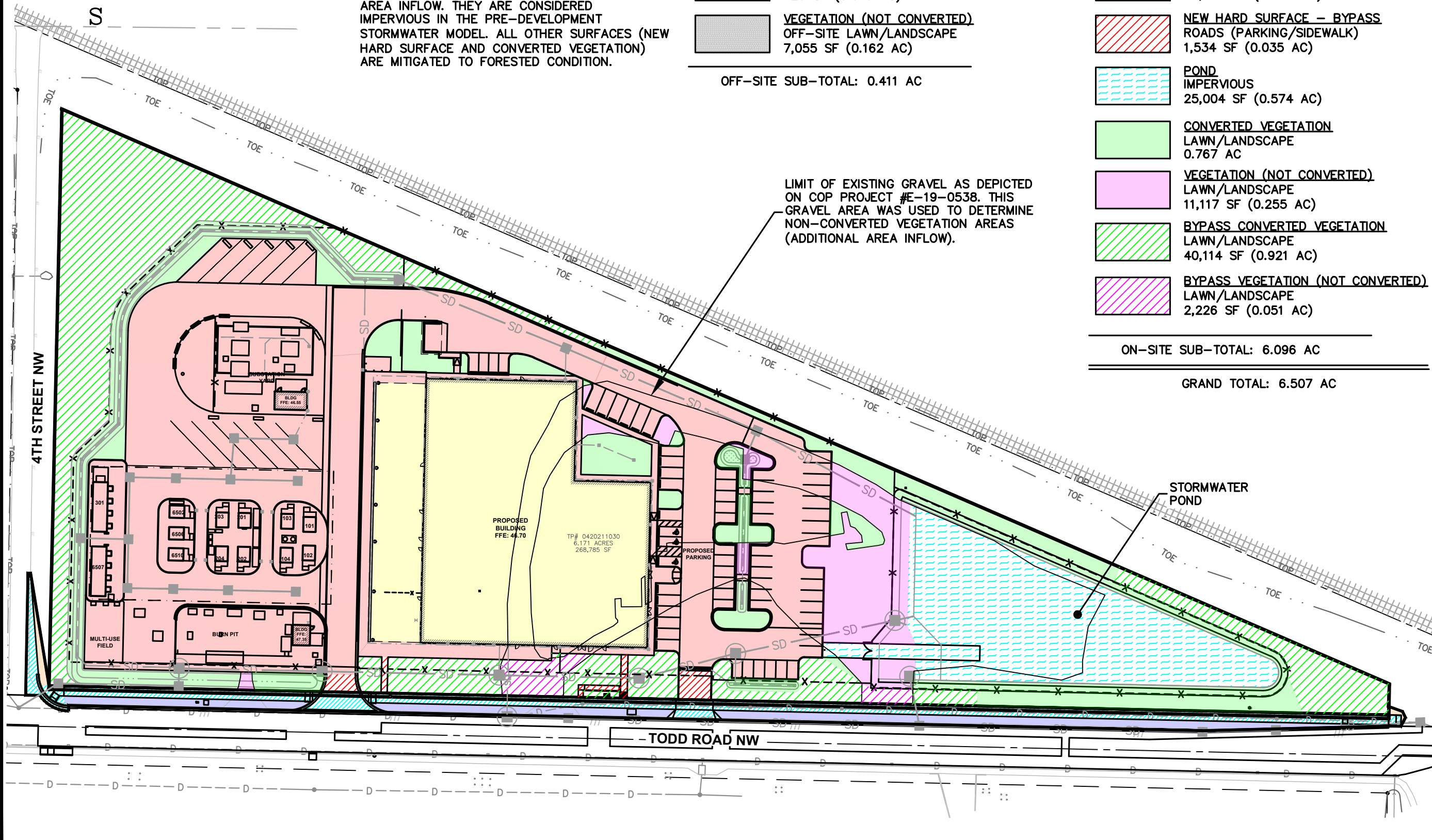
	NEW HARD SURFACE – BYPASS OFF-SITE ROADS (ROAD/SIDEWALK) 10,399 SF (0.239 AC)		NEW HARD SURFACE ROADS (PARKING/SIDEWALK) 109,172 SF (2.506 AC)
	CONVERTED VEGETATION OFF-SITE LAWN/LANDSCAPE 429 SF (0.010 AC)		NEW HARD SURFACE ROOF TOPS 42,978 SF (0.987 AC)
	VEGETATION (NOT CONVERTED) OFF-SITE LAWN/LANDSCAPE 7,055 SF (0.162 AC)		NEW HARD SURFACE – BYPASS ROADS (PARKING/SIDEWALK) 1,534 SF (0.035 AC)
			POND IMPERVIOUS 25,004 SF (0.574 AC)
			CONVERTED VEGETATION LAWN/LANDSCAPE 0.767 AC
			VEGETATION (NOT CONVERTED) LAWN/LANDSCAPE 11,117 SF (0.255 AC)
			BYPASS CONVERTED VEGETATION LAWN/LANDSCAPE 40,114 SF (0.921 AC)
			BYPASS VEGETATION (NOT CONVERTED) LAWN/LANDSCAPE 2,226 SF (0.051 AC)

OFF-SITE SUB-TOTAL: 0.411 AC

LIMIT OF EXISTING GRAVEL AS DEPICTED ON COP PROJECT #E-19-0538. THIS GRAVEL AREA WAS USED TO DETERMINE NON-CONVERTED VEGETATION AREAS (ADDITIONAL AREA INFLOW).

ON-SITE SUB-TOTAL: 6.096 AC

GRAND TOTAL: 6.507 AC



SHEET CONTENTS

POST-DEVELOPMENT BASIN MAP

220 W. Champion Street, Suite 200
 Bellingham, WA 98225
 t: 360.650.1408
 f: 360.650.1401



FREELAND
 & ASSOCIATES

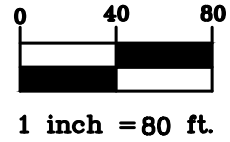
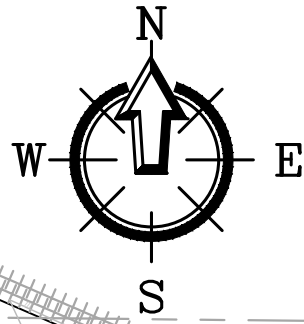
DATE
Dec. 2023

JOB #
22219

SHEET NAME
Fig. 7

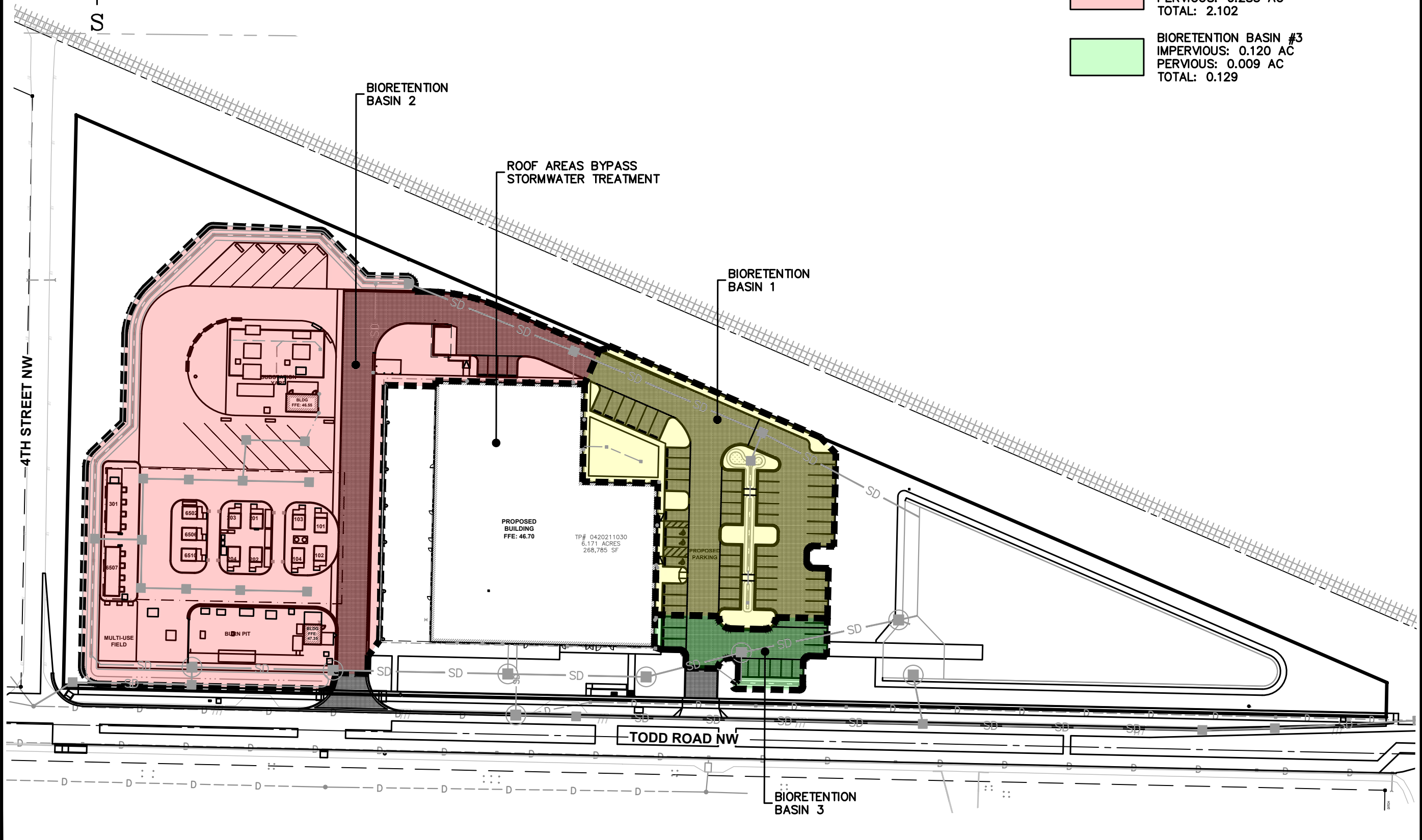
DRAWING #
22219SP19.DWG

Figure 8 - Stormwater Treatment Basin Map



DRAINAGE LEGEND

- BIORETENTION BASIN #1
 IMPERVIOUS: 0.540 AC
 PERVIOUS: 0.174 AC
 TOTAL: 0.714
- BIORETENTION BASIN #2
 IMPERVIOUS: 1.817 AC
 PERVIOUS: 0.285 AC
 TOTAL: 2.102
- BIORETENTION BASIN #3
 IMPERVIOUS: 0.120 AC
 PERVIOUS: 0.009 AC
 TOTAL: 0.129



SHEET CONTENTS

**STORMWATER TREATMENT
BASIN MAP**

220 W. Champion Street, Suite 200
 Bellingham, WA 98225
 t: 360.650.1408
 f: 360.650.1401

**F R E E L A N D
& A S S O C I A T E S**



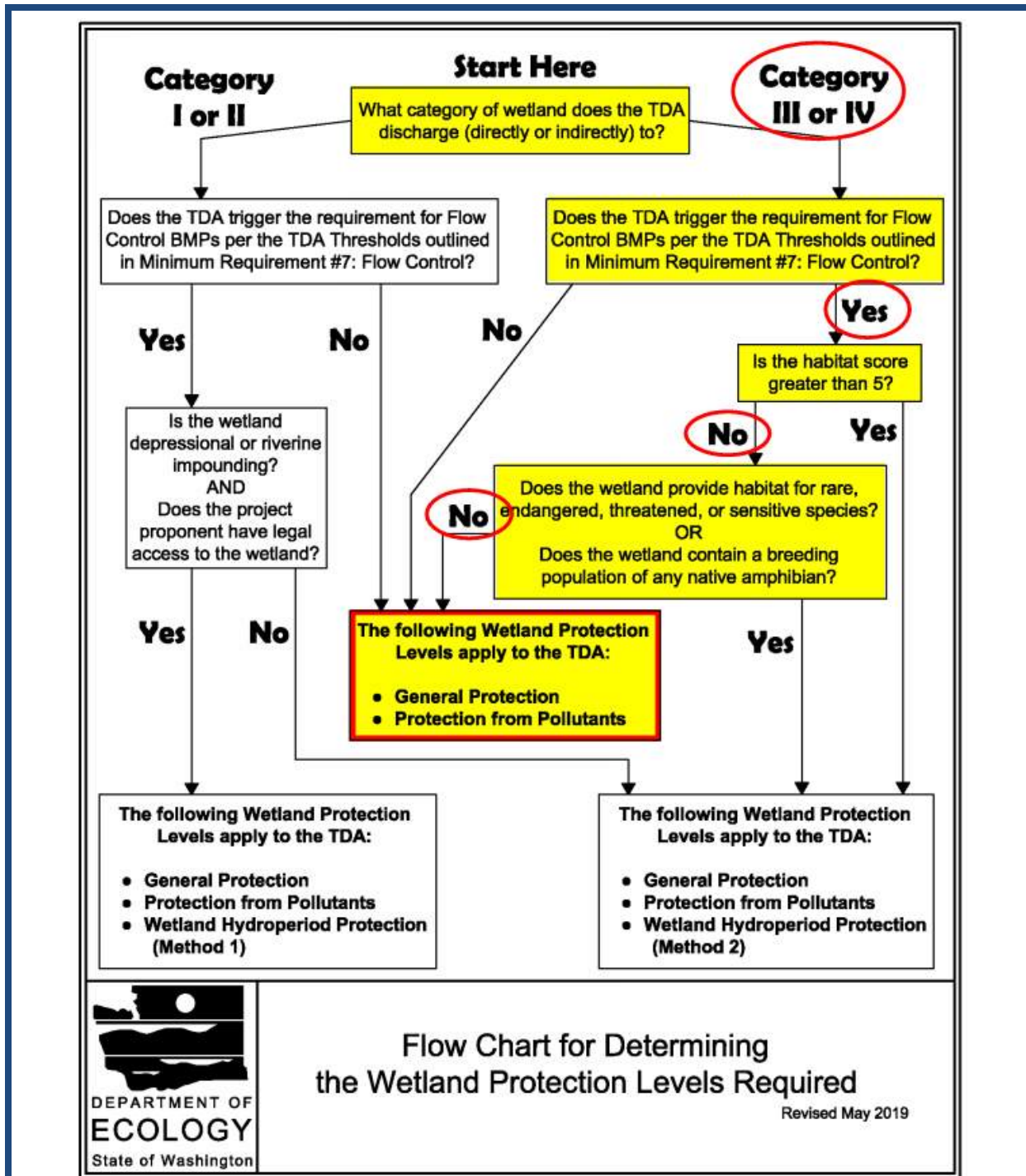
JOB # 22219

DRAWING # 22219SP19.DWG

DATE Dec. 2023

SHEET NAME

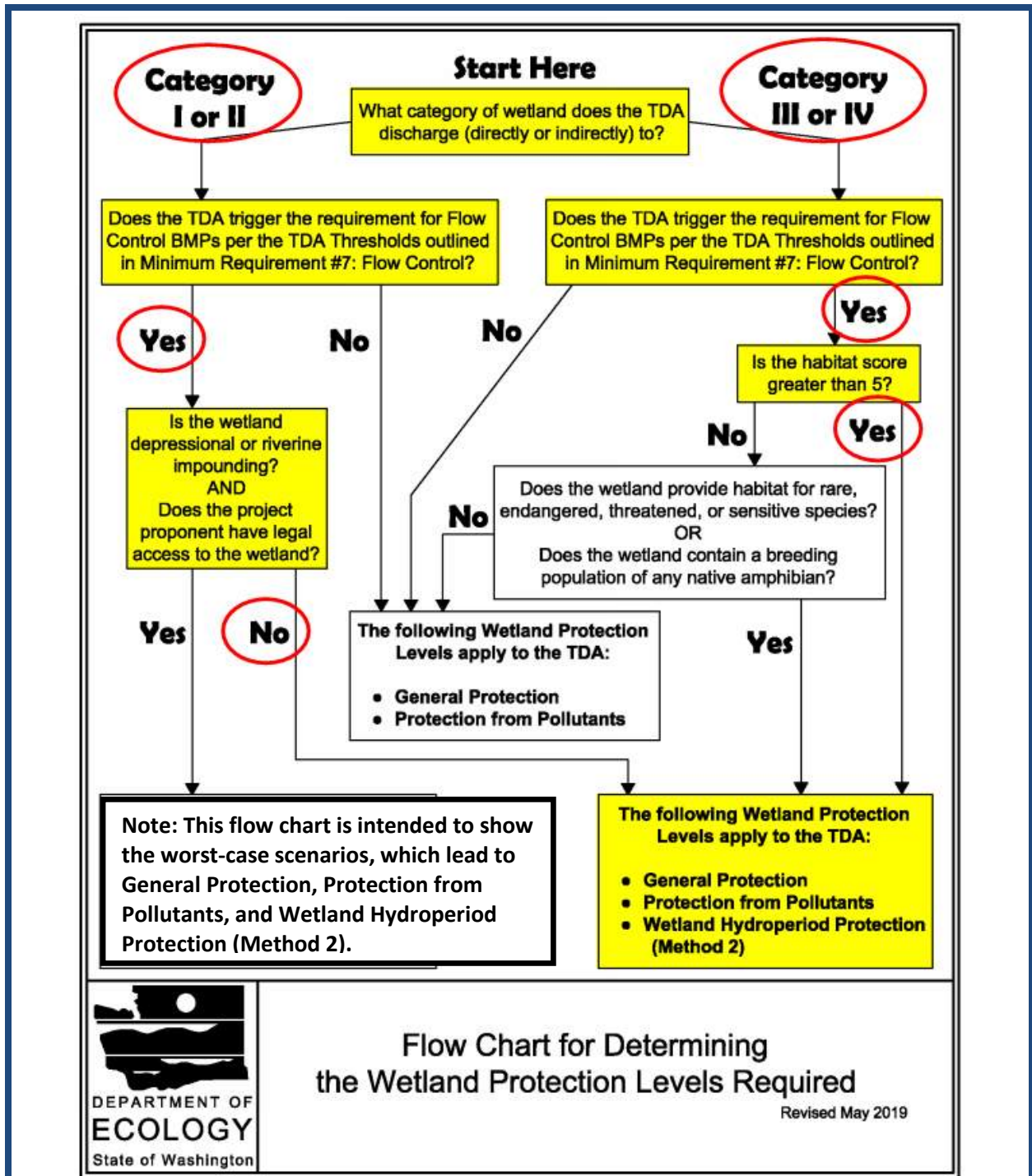
Fig. 8



DOE Wetland Protection
On-Site Wetland

Figure 9



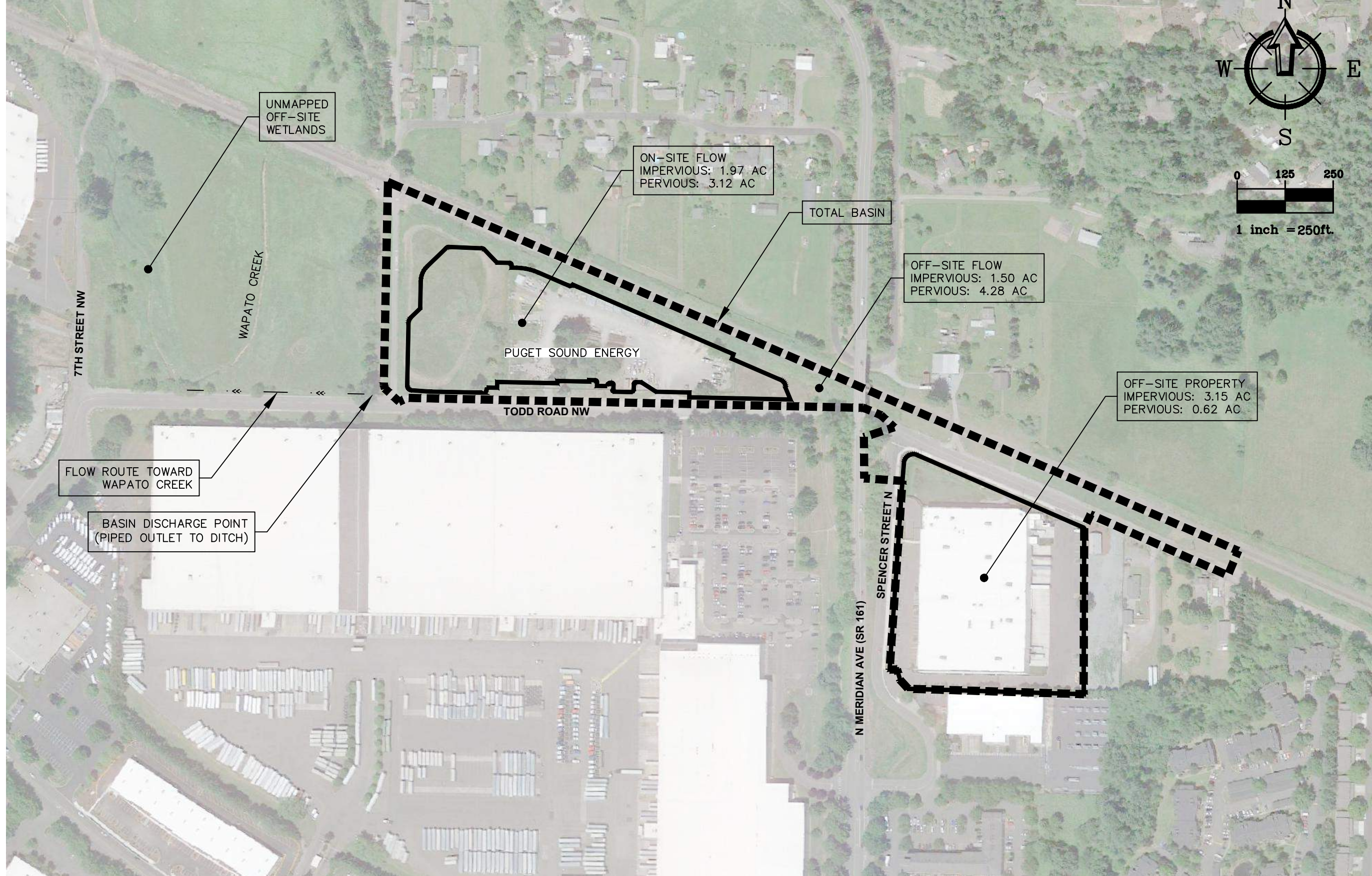


**DOE Wetland Protection
Off-Site Wetland**

Figure 10

Figure 11 – Pre-development Off-Site Wetland Basin





SHEET CONTENTS

**PRE-DEVELOPMENT
OFF-SITE WETLAND BASIN**

t: 360.650.1408
f: 360.650.1401

2500 Elm Street, Suite 1
Bellingham, WA 98225



**F R E E L A N D
& A S S O C I A T E S**

DATE

Dec. 2023

JOB #

22219

SHEET NAME

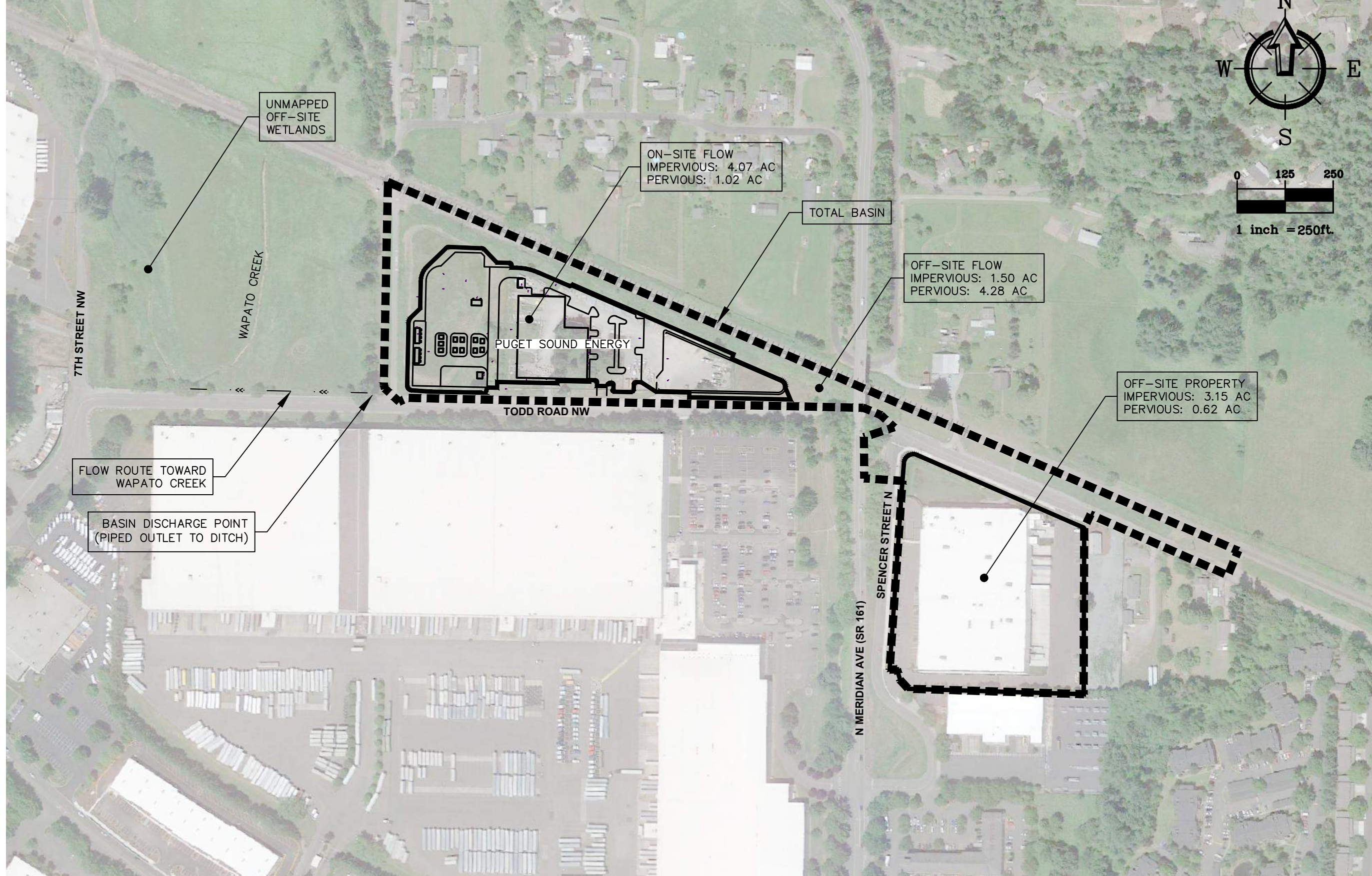
Fig. 11

DRAWING #

22219EXH1.DWG

Figure 12 – Post-development Off-Site Wetland Basin





SHEET CONTENTS

**PRE-DEVELOPMENT
OFF-SITE WETLAND BASIN**

t: 360.650.1408
f: 360.650.1401

2500 Elm Street, Suite 1
Bellingham, WA 98225

**F R E E L A N D
& A S S O C I A T E S**



DATE

Dec. 2023

JOB #

22219

SHEET NAME

Fig. 12

DRAWING #

22219EXH1.DWG

CALCULATIONS



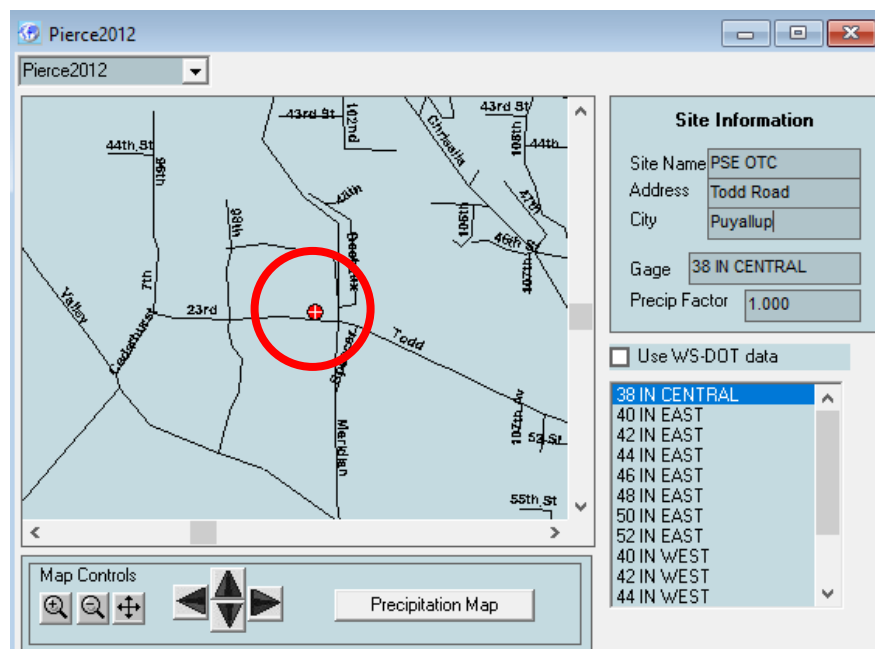
Stormwater Modeling Overview

In accordance with Puyallup Municipal Code 21.10.040 and the 2019 DOE Manual, Western Washington Hydrology Model v2012 (WWHM2012) software is used to model the anticipated stormwater flows and durations from the site. WWHM2012 software uses HSPF continuous simulation methodology to compare predevelopment discharge rates to post development discharge rates from 50% of the 2-year peak flow up to the full 50-year peak flow.

WWHM2012 has three categories for slopes: 0-5% flat, 5%-15% moderate, 15%+ steep. Slopes within the project site are generally flat and will be considered flat in the predevelopment and developed scenarios. Soils on the site belong to hydrologic groups 'A' and 'C/D', as mapped by the Natural Resources Conservation Service (NRCS), described previously in this report. For the purposes of stormwater modeling, all soil types will be considered 'C' due to the presence of shallow groundwater and low infiltration potential.

A 15-minute timestep will be used for this analysis. Precipitation data for the design uses the Puyallup 38-inch Central rain gage. Figure C1 below identifies the location of the project and WWHM2012 calculates the difference in rainfall with a precipitation scaling factor of 1.000.

Figure C1 – Rain Gage Scaling



Considered new development, the project is required to provide flow control for the ***new and replaced*** hard surfaces and ***converted*** vegetation areas. Therefore, all ***new and replaced*** hard surfaces and ***converted*** vegetation areas will be considered forested in the predevelopment scenario.

Portions of the project site have already been developed with gravel surfacing and lawn areas. Therefore, there will be areas where new pervious surfaces are not considered a converted vegetation area. Based on correspondence with Department of Ecology, these areas with existing gravel that will be a pervious surface at completion of the project will be modeled as they exist in the predevelopment scenario (which is gravel). These are considered additional area inflow per the DOE Manual. A separate stormwater model will be prepared to ensure that the performance of the flow control BMP will not be compromised. Refer to the Appendix for stormwater modeling results demonstrating that the existing 100-year peak flow rate from the additional area is not greater than 50% of the 100-year developed peak flow rate (undetained) from the area requiring mitigation.

Roadwork including trenching, pavement replacement, grinding and overlaying will be necessary for completing utility extensions along City streets. Work associated with utility extensions is considered exempt from Minimum Requirements except for Minimum Requirement 2: Construction Stormwater Pollution Prevention Plan (SWPPP).

WWHM2012 software is used to determine the required size of the system that will meet the flow control standard in 2019 DOE Manual. Online stormwater treatment will be upstream of detention using bioretention cells for filtration. Stormwater treatment systems will be sized to treat at least 91% of the runoff volume using WWHM2012.

Existing Conditions (Predevelopment)

For modeling purposes, new and replaced impervious surfaces and converted vegetation areas are subject to flow control requirements and considered forested in the predevelopment scenario. Areas proposed to be new lawn/landscaping where existing gravel exists, will be modeled as they exist in the predevelopment scenario, which is gravel. Refer to Table C1 below for a summary of the predeveloped modeling conditions of the project and Figure 7 for a graphical depiction of the contributing basin.

Table C1 Predevelopment Modeling Characteristics	
Type	Area (Acres)
On-Site Basin	
Forest	5.790
Parking (Existing Gravel)	0.306
Total Sub-Basin	6.096
Off-site Basin	
Forest	0.249
Parking (Existing Gravel)	0.162
Total Sub-Basin	0.411
Grand Total	6.507



Proposed Conditions (Post-developed)

Refer to Table C2 below for a summary of the post-developed modeling conditions for the project and Figure 7 for a graphical depiction of the contributing basin draining to the flow control facility.

Table C2 Post-development Modeling Characteristics	
Type	Area (Acres)
On-Site Basin	
Roads (Parking/Sidewalk)	2.506
Roof Tops	0.987
Pond	0.574
Lawn* (Converted Vegetation)	0.767
Lawn* (Not Converted Vegetation)	0.255
Total Sub-Basin	5.089
On-Site Bypass Basin	
Driveways (Parking/Sidewalk)	0.035
Lawn* (Converted Vegetation)	0.921
Lawn* (Not Converted Vegetation)	0.051
Total Sub-Basin	1.007
Off-Site Bypass Basin	
Roads (Roads/Sidewalk)	0.239
Lawn* (Converted Vegetation)	0.010
Lawn* (Not Converted Vegetation)	0.162
Total Sub-Basin	0.411
Grand Total	6.507

*Note: Lawn is modeled as pasture per modeling credit associated with BMP T5.13.



Stormwater Modeling Input & Output - Flow Control Calculations

Screenshots of the software model are provided below. The left half of each screenshot shows the entire pre- or post-development stormwater model layout with a single component selected. The right half of each screenshot provides input information for the selected component of the model.

Figure C2 – Pre-development On-Site Basin

The screenshot displays the software interface for configuring a pre-development on-site basin. The left pane, titled "SCENARIOS", shows a grid of model components. A component is selected and circled in red. The right pane, titled "On-site Pre Predeveloped", shows the input parameters for the selected component.

Subbasin Name: On-site Pre

Flows To: Surface, Interflow, Groundwater

Area in Basin Show Only Selected

Available Pervious	Acres	Available Impervious	Acres
<input checked="" type="checkbox"/> C. Forest, Flat	5.79	<input checked="" type="checkbox"/> PARKING/FLAT	306

Summary:

Pervious Total	5.79	Acres
Impervious Total	0.306	Acres
Basin Total	6.096	Acres

Buttons: Deselect Zero, Select By: GO



Figure C3 – Pre-development Off-Site Basin

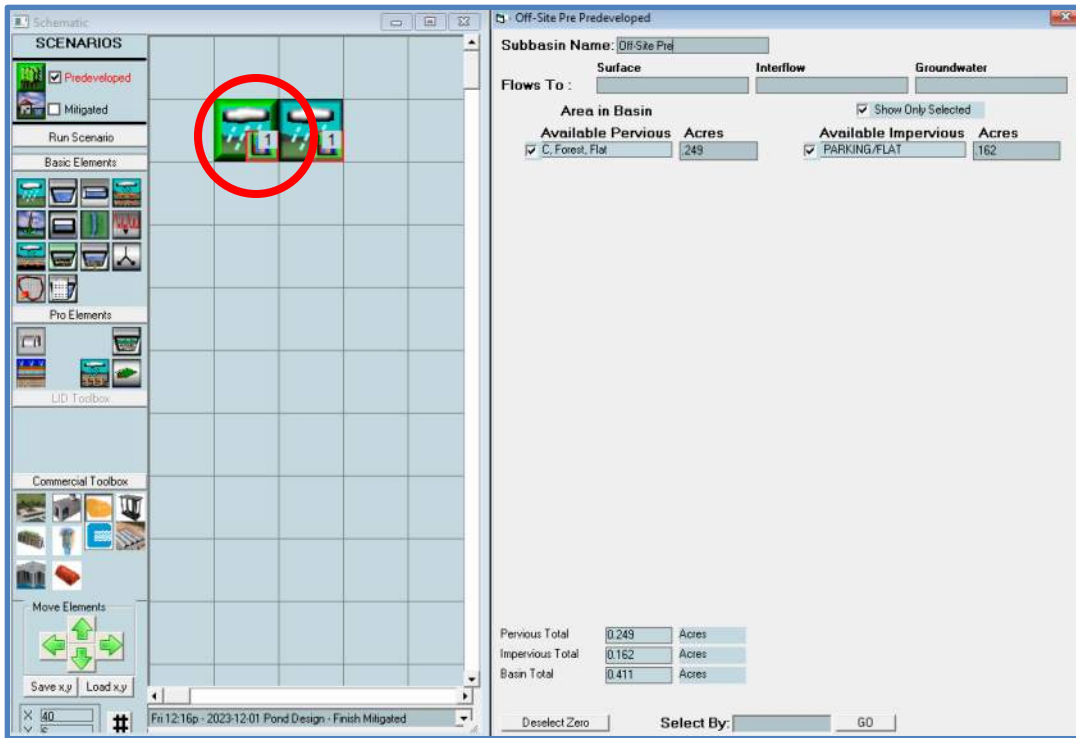


Figure C4 - Post-development On-Site Basin

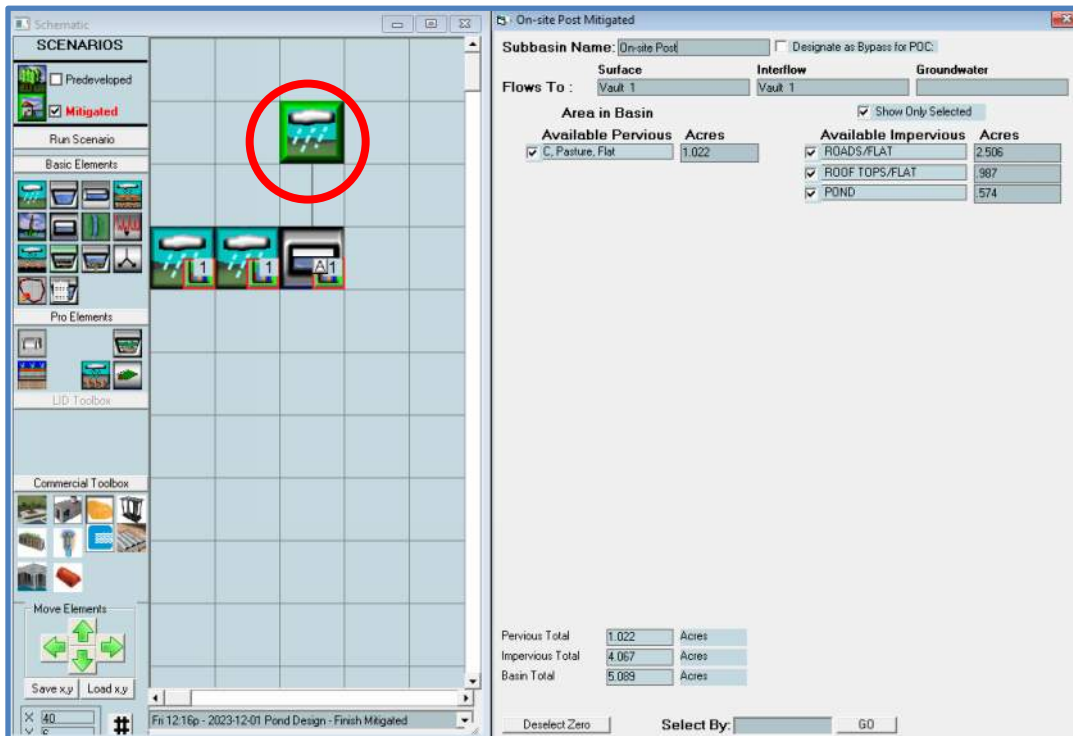


Figure C5 - Post-development On-Site Bypass Basin

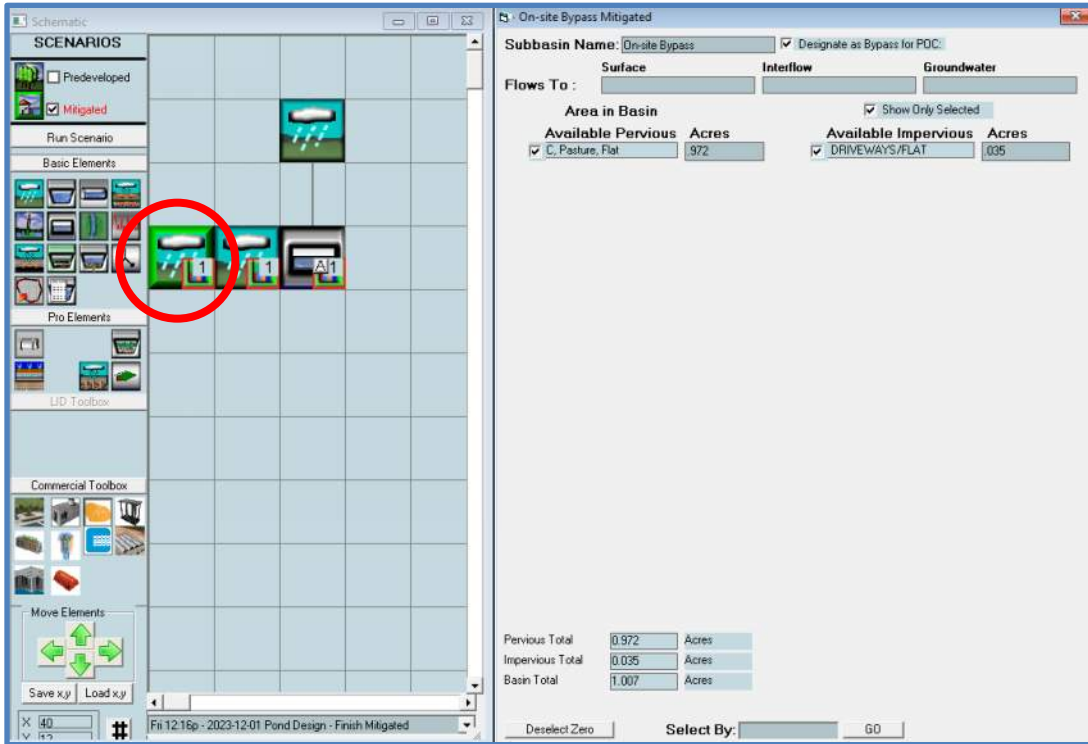


Figure C6 - Post-development Off-Site Bypass Basin

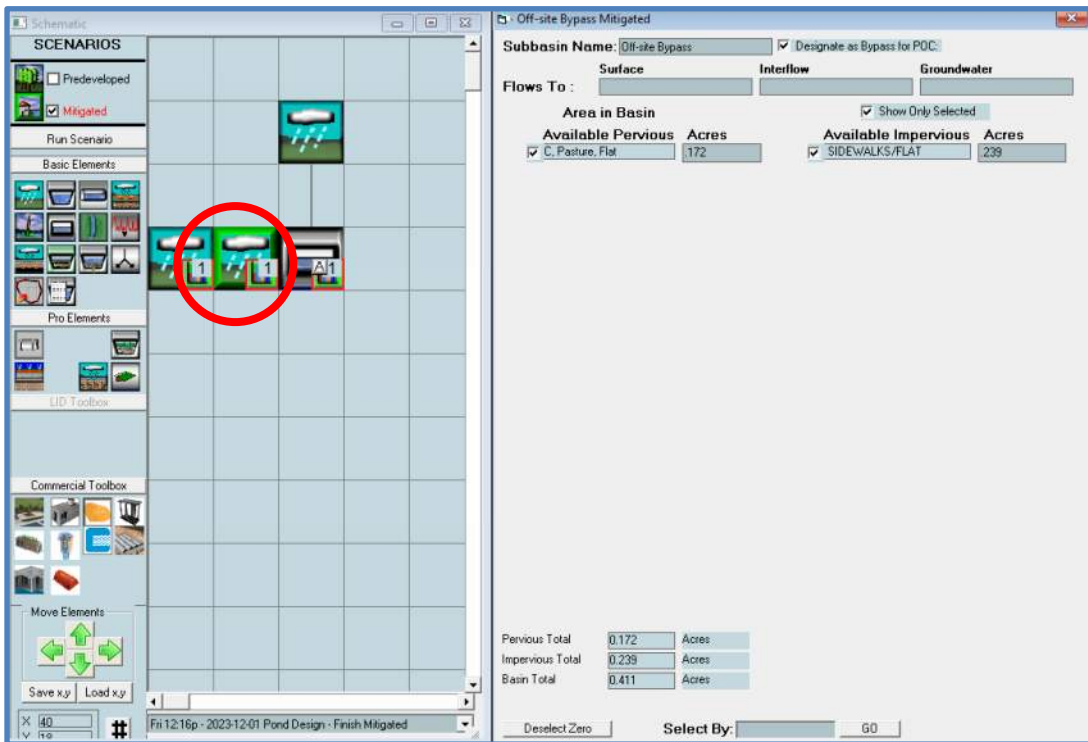


Figure C7 - Detention Design

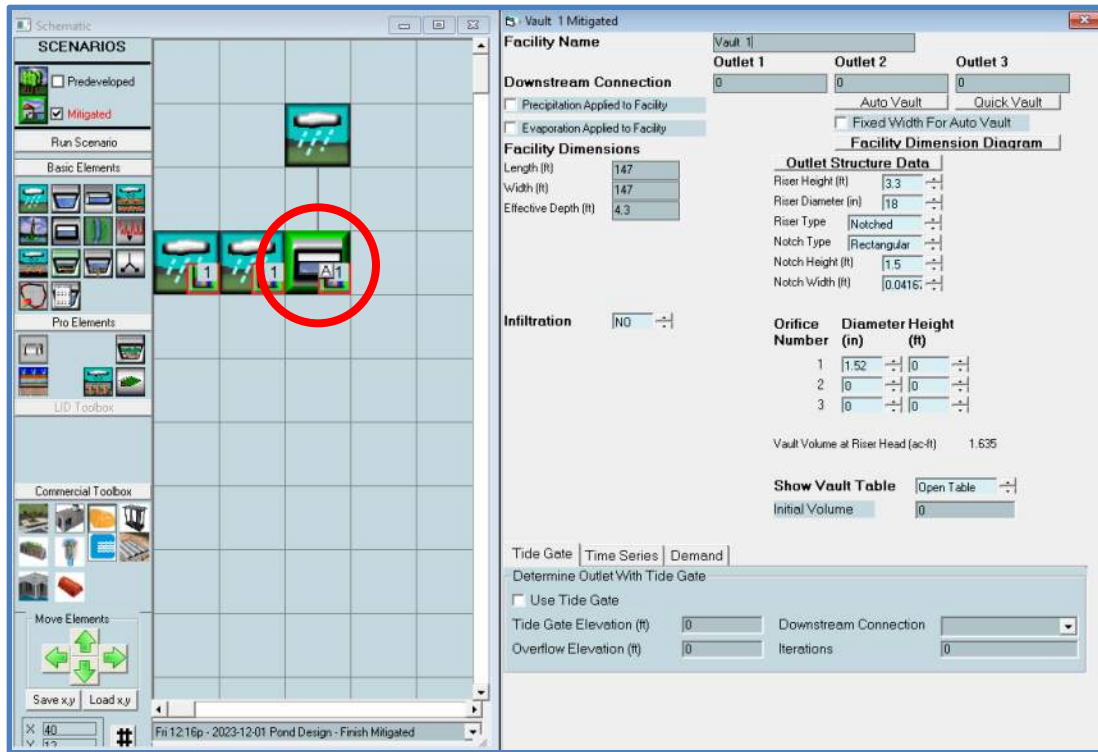


Figure C8 - Stream Protection Duration Analysis

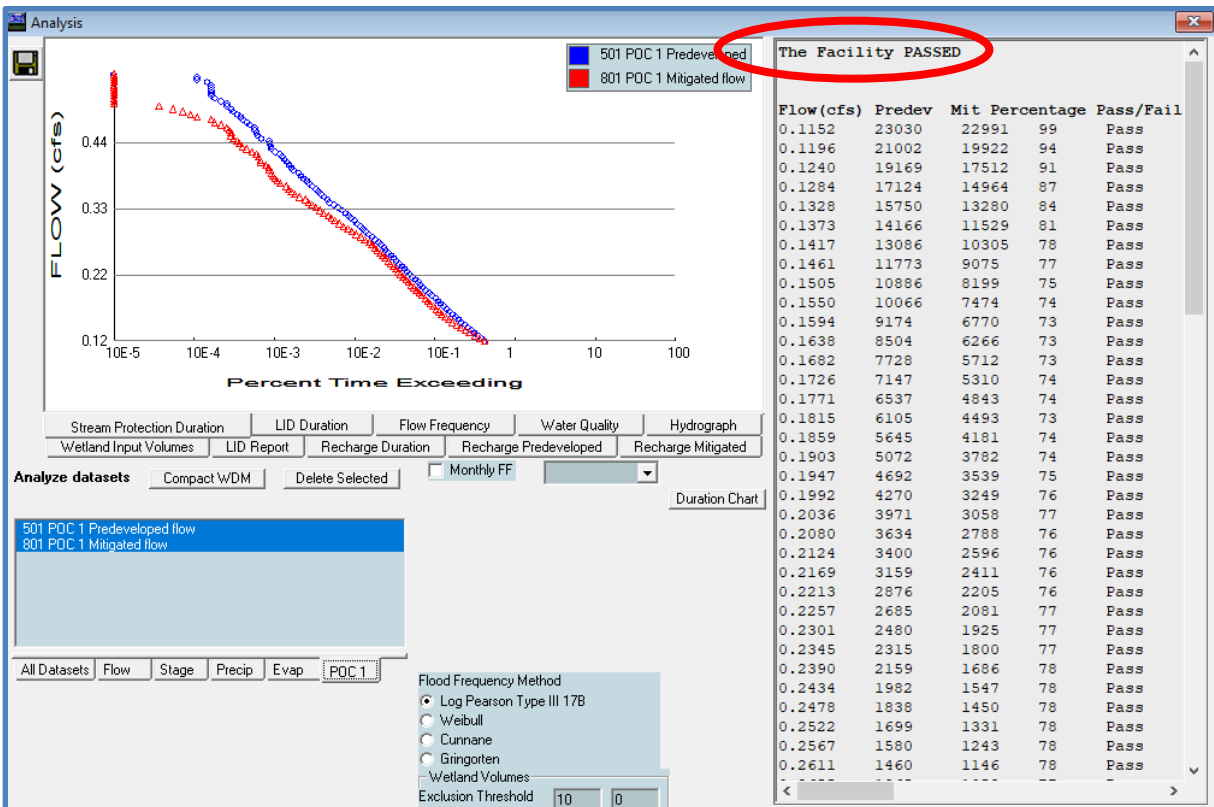
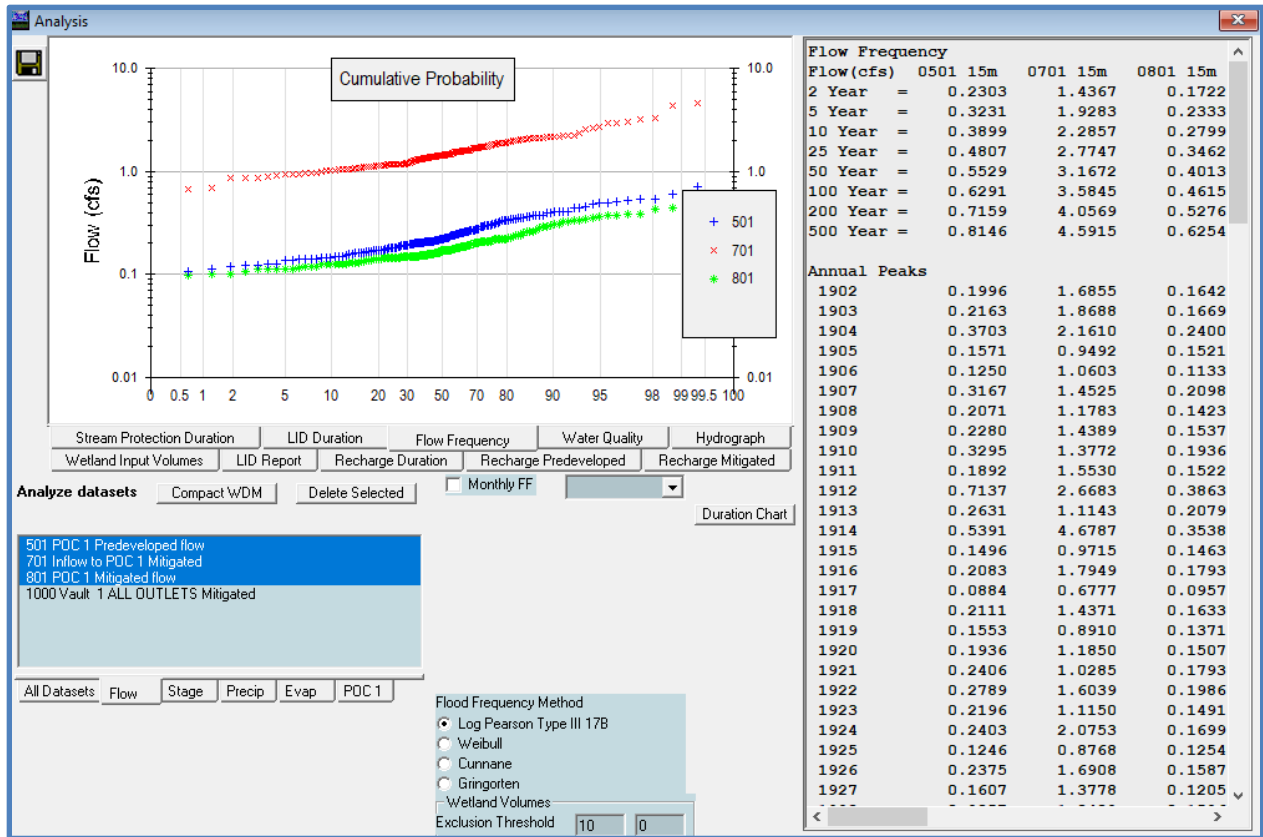


Figure C9 - Flow Frequency Analysis



Based on stormwater modeling, the detention system must be at least 147 feet long x 147 feet wide x 3.3 feet tall, or an equivalent volume of 71,310 cubic feet. The proposed stormwater detention pond design includes a designed storage volume of 79,400 cubic feet which exceeds the necessary volume. Therefore, the design meets the requirements.

The detention pond will be designed to ensure the outlet is above expected high groundwater. High groundwater is located at elevation 39, the pond outlet is at elevation 40.

BMP T7.30 – Bioretention

Three bioretention cells are proposed to provide on-line treatment of stormwater runoff. Each cell has over 5,000 square feet of tributary area. The bioretention cell section consists of 18-inches of Bioretention Soil Mix over 18-inches of Mineral Aggregate Type 21. The Bioretention Soil Mix will be Ecology's default mix with an initial Ksat of 12 in/hr and a safety factor of 4. Based on geotechnical analysis, infiltration is infeasible, therefore no infiltration rate will be applied to the bioretention cell design. Refer to Figure 8 for a summary of the post-developed modeling conditions for each basin and a graphical depiction of the tributary area draining to each bioretention cell.

Stormwater Modeling Input & Output – Bioretention Treatment Calculations

Screenshots of the software model for the bioretention treatment calculations are provided below. The left half of each screenshot shows the entire pre- or post-development stormwater model layout with a single component selected. The right half of each screenshot provides input information for the selected component of the model.



Figure C10 – Bioretention Basin 1

Basin 1 Configuration

Subbasin Name: Basin 1

Flows To: Surface (Surface orientation 1), Interflow (Surface orientation 1), Groundwater

Area in Basin (Show Only Selected):

Available Pervious	Acres	Available Impervious	Acres
<input checked="" type="checkbox"/> C, Pasture, Flat	0.174	<input checked="" type="checkbox"/> ROADS/FLAT	0.54

Pervious Total: 0.174 Acres
 Impervious Total: 0.54 Acres
 Basin Total: 0.714 Acres

Figure C11 – Bioretention 1 Analysis

Bioretention 1 Analysis Parameters

Facility Name: Bioretention 1

Downstream Connection: Outlet 1 (0), Outlet 2 (0), Outlet 3 (0)

Use simple Bioretention

Underdrain Used

Underdrain Diameter (ft): 0.5
 Orifice Diameter (in): 5.9
 Flow Through Underdrain (ac-ft): 224.687
 Total Outflow (ac-ft): 245.584

Bioretention Dimensions

Bioretention Length (ft)	160.000
Bioretention Bottom Width (ft)	2.000
Freeboard (ft)	0.500
Over-road Flooding (ft)	0.000
Effective Total Depth (ft)	3.7
Bottom slope of bioretention (0-1)	0.000

WQ Percent Filtered: 91.4%

Facility Dimension Diagram

Sidewall Invert Location

Front and Back side slope (H/V): 3.000
 Left Side Slope (H/V): 3.000
 Right Side Slope (H/V): 3.000

Riser Height Above bioretention surface (ft): 0.2
 Riser Diameter (in): 10
 Riser Type: Flat

Material Layers for

Layer	Depth (ft)	Soil Layer
Layer 1	1.500	SMMwW/12 in/hr
Layer 2	1.500	GRAVEL
Layer 3	0.000	GRAVEL

KSet Safety Factor: None, 2, 4

Orifice Diameter Height Table:

Orifice Number	Diameter (in)	Height (ft)
1	0	0
2	0	0
3	0	0

Bioretention Volume at Riser Head (ac-ft): .119

Native Infiltration: NO

Total Inflow ac-ft: 262.57
 Precipitation on Facility (acre-ft): 27.574
 Evaporation from Facility (acre-ft): 16.995

Figure C12 – Bioretention Basin 2

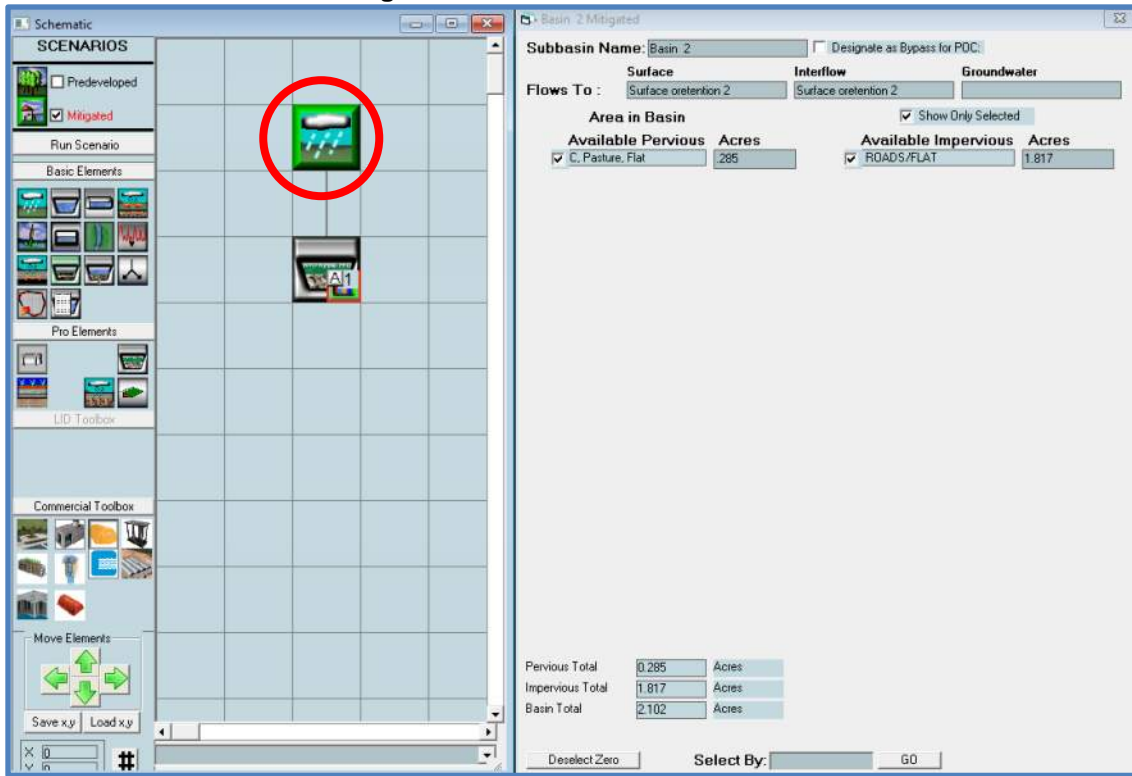


Figure C13 – Bioretention 2

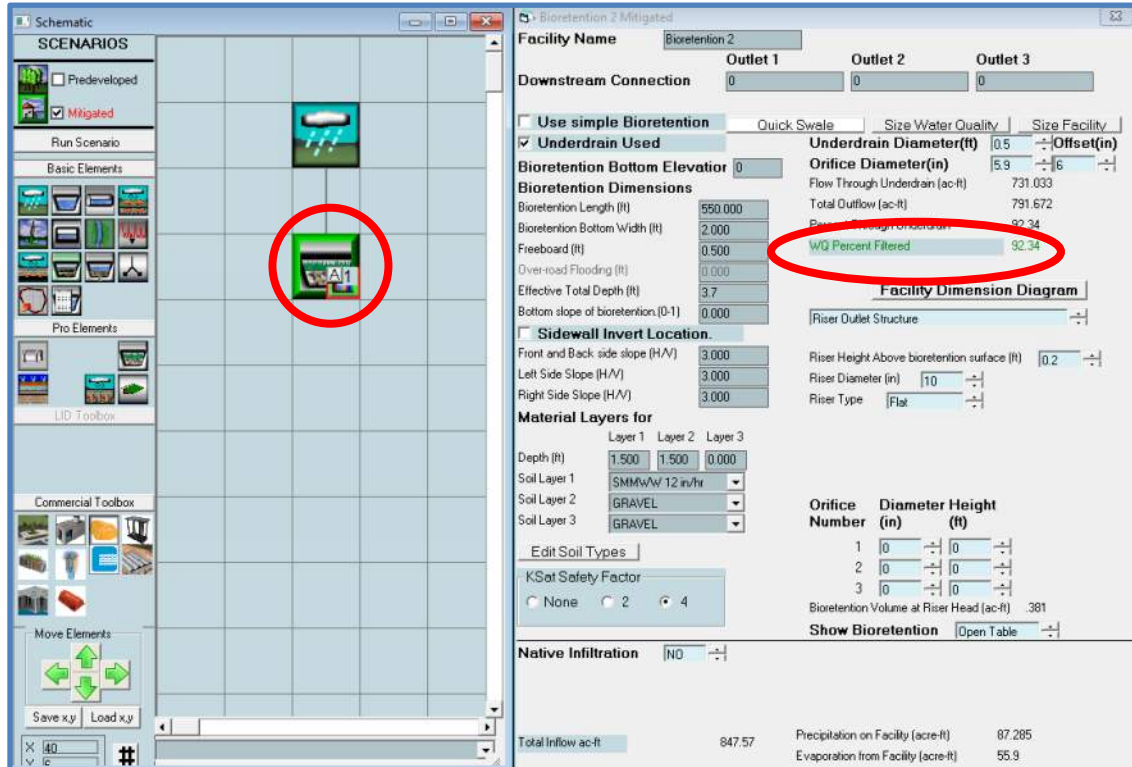


Figure C14 – Bioretention Basin 3

Basin 3 Configuration Summary:

- Subbasin Name: Basin 3
- Flows To: Surface (Surface retention 3), Interflow (Surface retention 3), Groundwater
- Area in Basin:

Available Pervious	Acres	Available Impervious	Acres
C. Pasture, Flat	.009	ROADS/FLAT	.12
Pervious Total	0.009		
Impervious Total	0.12		
Basin Total	0.129		

Figure C15 – Bioretention 3 Analysis

Bioretention 3 Analysis Parameters:

- Facility Name: Bioretention 3
- Outlet 1, 2, 3: 0
- Use simple Bioretention: Quick Swale, Size Water Quality, Size Facility
- Underdrain Used
 - Underdrain Bottom Elevator: 0
 - Underdrain Diameter (ft): 0.5
 - Orifice Diameter (in): 5.9
 - Flow Through Underdrain (ac-ft): 50.407
 - Total Outflow (ac-ft): 52.936
 - WQ Percent Filtered: 95.22
- Bioretention Dimensions:
 - Bioretention Length (ft): 45,000
 - Bioretention Bottom Width (ft): 2,000
 - Freeboard (ft): 0.500
 - Over-load Flooding (ft): 0.000
 - Effective Total Depth (ft): 3.7
 - Bottom slope of bioretention (0-1): 0.000
- Material Layers for:

Layer	Depth (ft)	Soil Layer
Layer 1	1,500	SMMW/W 12 in/hr
Layer 2	1,500	GRAVEL
Layer 3	0,000	GRAVEL
- Orifice Details:

Orifice Number	Diameter (in)	Height (ft)
1	0	0
2	0	0
3	0	0
- Native Infiltration: NO
- Total Inflow ac-ft: 58.233
- Precipitation on Facility (acre-ft): 9.021
- Evaporation from Facility (acre-ft): 5.297

As shown in figures above, bioretention cells will provide on-line treatment with greater than 91% filtration per the 2019 DOE Manual. Therefore, the bioretention cells shown in the proposed civil plans are adequately sized to filter their contributing sub-basins. Groundwater is expected to remain below the bottom of bioretention cells, therefore, no impermeable lines are specified. See civil plans for complete treatment facility designs and details.



Emergency Overflow Conveyance Capacity

Stormwater runoff will discharge from the site's flow control facility using 15-inch diameter pipe at a minimum slope of 0.5 percent. Mitigated and un-mitigated 15-minute 100-year stormwater flow rates from the stormwater management facility are shown in Figure C9 above.

Given:

- Peak 100-year undetained flow rate from flow control facility: = 3.58 cfs
- Discharge Pipe Minimum Slope: 0.50%
- Pipe Diameter: 15 inches

Determine:

- Pipe Suitability

From Manning's Pipe Calculator:

Inputs				Results			
Pipe diameter, d_0	15	in	X	Flow depth, y	1.1750	ft	X
Manning roughness, n	0.015		X	Flow area, a	1.1971	ft ²	X
Pressure slope (possibly ? equal to pipe slope), S_0	0.5	% rise/run	X	Pipe area, a_0	1.2272	ft ²	X
Relative flow depth, y/d_0	0.94	fraction	X	Relative area, a/a_0	0.9755	fraction	X
				Wetted perimeter, P_w	3.3083	ft	X
				Hydraulic radius, R_h	0.3618	ft	X
				Top width, T	0.5937	ft	X
				Velocity, v	3.5569	ft/sec	X
				Velocity head, h_v	0.1966	ft H ₂ O	X
				Froude number, F	0.44		X
				Average shear stress (tractive force), τ	0.1130	psf	X
				Flow, Q (See notes)	4.2579	cfs	X
				Full flow, Q_0	3.9583	cfs	X
				Ratio to full flow, Q/Q_0	1.0757	fraction	X

<http://www.hawsedc.com/engcalcs/Manning-Pipe-Flow.php>

$$Q_{100} = 3.58 \text{ cfs}$$

$$Q_{\text{CAPACITY}} = 4.25 \text{ cfs}$$

Therefore, the proposed 15-inch pipe is sized to safely convey the anticipated 100-year unmitigated post-development runoff flow rates from the flow control facility.

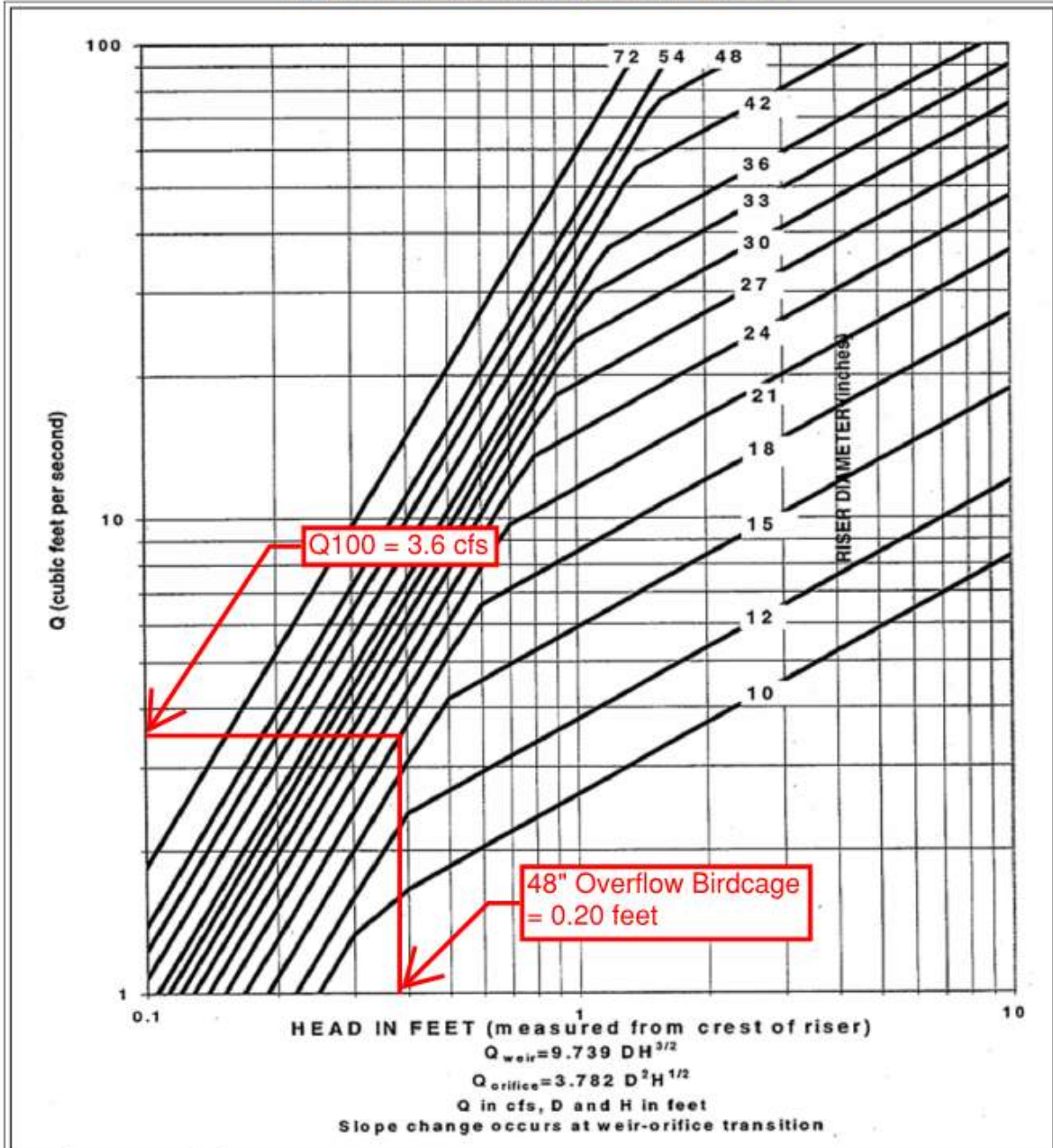
The detention system will be equipped with a riser pipe with an open top in the control structure to receive flows when ponding is deeper than intended. In addition, a second emergency overflow



consisting of an open-topped 48-inch diameter catch basin (in lieu of a spillway) will be provided. In the event of an overflow, water will spill over the 48-inch diameter riser. Head over the top of the overflow is determined using Figure V-12.8: Riser Inflow Curves from the 2019 DOE Manual. As shown in the figure below, 100-year undetained flow rates will result in 0.20 feet of head over the top of the emergency overflow.



Figure V-12.8: Riser Inflow Curves



Riser Inflow Curves

Revised June 2016

Please see <http://www.ecy.wa.gov/copyright.html> for copyright notice including permissions, limitation of liability, and disclaimer.



Wetland Hydroperiod Analysis

A wetland hydroperiod analysis following Method 2 as outlined in Volume I, Section I-C.4 of the DOE Manual has been prepared for the off-site unmapped wetland. Method 2 compares the wetland's existing condition basin and proposed condition basin using WWHM's Wetland Input Volume analysis. A contributing basin for the off-site wetland was identified using aerial photography, City of Puyallup online mapping, and City Record Drawings. To be conservative, the contributing basin is limited to runoff discharging from the Todd Road NW storm conveyance system that outfalls to the roadside ditch. The analysis does not include Wapato Creek stream flow other basin areas that may contribute to Wapato Creek flow upstream of the project. Refer to Table C3 and C4 below for a summary of basin ground cover conditions and Figure 12 and 13 for a graphical depiction of the pre-development and post-development contributing basin.

Table C3 Existing Condition Modeling Characteristics			
Sub-basin	Impervious (Acres)	Pervious (Acres)	Total Su-basin (Acres)
Off-Site Property	3.15	0.62	3.77
Off-Site Flow	1.50	4.28	5.78
On-Site Flow	1.97	3.12	5.09
Total Area	6.62	8.02	14.64

Table C3 Proposed Condition Modeling Characteristics			
Sub-basin	Impervious (Acres)	Pervious (Acres)	Total Su-basin (Acres)
Off-Site Property	3.15	0.62	3.77
Off-Site Flow	1.50	4.28	5.78
On-Site Flow	4.07	1.02	5.09
Total Area	6.62	8.02	14.64



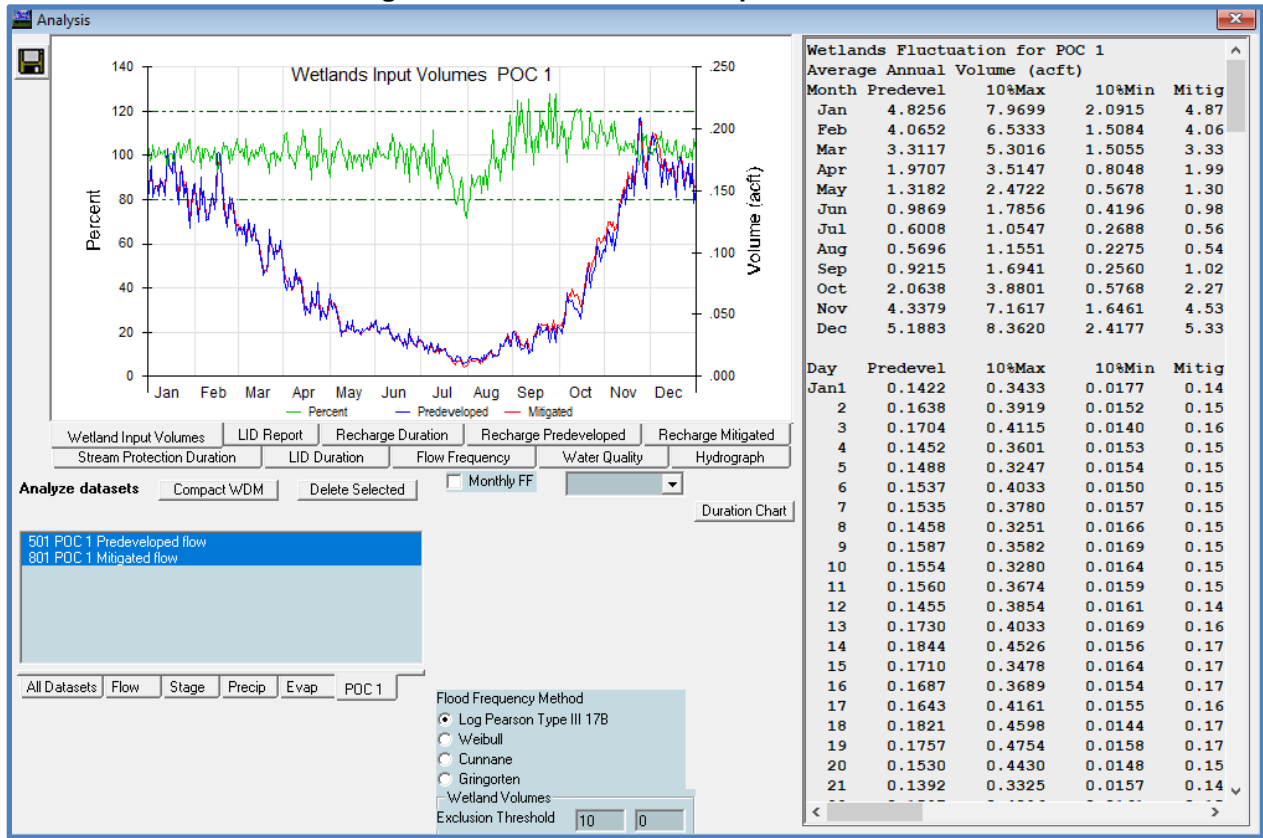
Figure C16 – Wetland Basin Existing Condition



Figure C17 – Wetland Basin Developed Condition



Figure C18 – Wetland Basin Input Volumes



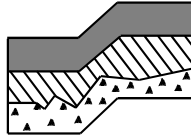
Full results of the stormwater model for the hydroperiod analysis are provided in the Appendix of this report. All monthly volumes pass with limited days from July to October that fail. Refer to the Wetland Report in the Appendix for more information regarding how the hydroperiod is not anticipated to negatively impact the off-site wetland area.

APPENDIX



Geotechnical Evaluation

MEMORANDUM



TERRA ASSOCIATES, Inc.

Consultants in Geotechnical Engineering, Geology
and
Environmental Earth Sciences

To: Alex Garcia Mendoza Date: 12-4-23
Trammell Crow Company Project No.: T-8829
From: Ted Schepper, P.E. Project Name: PSE Operation Training Center
Subject: Response to City Comments Puyallup, Washington
Ref: Terra Associates Geotechnical Report, PSE Operational Training Center, revised dated 8-28-23

Alex,

As requested by the project civil engineer, Freeland and Associates, we have reviewed two comments from the City of Puyallup regarding the stormwater drainage design. The first relates to the bioretention swale located above and adjacent to a fill embankment at the northwest perimeter of the site. The city requested confirmation from us that the infiltrated stormwater would not impact the stability of the fill embankment. In their second comment the city requested an expanded narrative regarding infiltration rates used in design of the permeable pavement. The following summarizes our responses:

Review of the section through the bioretention swale shows the fill embankment will be slightly less than five feet high and sloped at a gradient of 3:1 (horizontal: vertical). The swale design includes an underdrain that will collect stormwater treated by infiltration through the bioretention soil mix and convey the treated stormwater to discharge into the developments stormwater detention pond located in the eastern portion of the site. Provided the embankment fill is compacted structurally as recommended in the referenced report and the underdrain is installed, stormwater collected by and infiltrated below the swale would have no adverse impact on the stability of the fill embankment.

As discussed in our referenced report, soil conditions at the site are alluvial sediments. These soils were deposited by the Puyallup River following retreat of the glaciers and are unconsolidated deposits. Infiltration rates discussed in the referenced report for design of low impact development (LID) features such as permeable pavement and bioretention cells are based on our experience and as allowed by Ecology's Stormwater Management Manual for Western Washington (Manual), results of grain size analysis. We would note that the rates recommended represent saturated permeability values (K_{sat}) of less than .3 inches per hour which in the Manual, is a threshold below which permeable pavement and bioretention for managing stormwater runoff is considered infeasible.

If you have any questions or require additional information, please call.

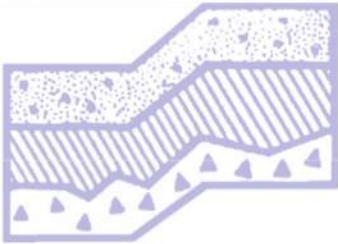

Theodore J. Schepper
12-4-23

Cc: Miles McEathron, P.E., Freeland and Associates, Inc.

GEOTECHNICAL REPORT

**PSE Operational Training Center
325 Todd Road Northwest
Puyallup, Washington**

Project No. T-8829



Terra Associates, Inc.

Prepared for:

**Trammell Crow Company
Seattle, Washington**

**April 6, 2023
Revised August 28, 2023**



TERRA ASSOCIATES, Inc.

Consultants in Geotechnical Engineering, Geology
and
Environmental Earth Sciences

April 6, 2023
Revised August 28, 2023
Project No. T-8829

Mr. Alex Garcia Mendoza
Trammell Crow Company
600 University Street, Suite 2912
Seattle, Washington 98101

Subject: Geotechnical Report
PSE Operational Training Center
325 Todd Road Northwest
Puyallup, Washington

Dear Mr. Mendoza:

As requested, we have conducted a geotechnical engineering study for the subject project. The attached report presents our findings and recommendations for the geotechnical aspects of project design.

Our field exploration indicates the site is generally underlain by native alluvial sediments composed of alternating and interbedded layers of soft to stiff silt to clayey silt, and very loose to medium dense sand to silty sand. Below a depth of approximately 15 feet beneath existing surface grades, the relative density of the sand deposits becomes medium dense to very dense as indicated by some of the test borings and the deeper CPT data. Groundwater is shallow residing between five and ten feet below the current site grades at the time our field work was completed.

In our opinion, the native soils on the site will be suitable for support of the proposed development provided the recommendations presented in this report are incorporated into project design and construction.

We trust the information presented is sufficient for your current needs. If you have any questions or require additional information, please call.

Sincerely yours,
TERRA ASSOCIATES, INC.


Michael J. Xenos, E.I.T.
Staff Engineer


Theodore J. Schepper, F.E.
Senior Principal Engineer



8-28-23

TABLE OF CONTENTS

	<u>Page No.</u>
1.0	Project Description..... 1
2.0	Scope of Work..... 1
3.0	Site Conditions 2
3.1	Surface..... 2
3.2	Subsurface 2
3.3	Groundwater..... 3
3.4	Geologically Hazardous Areas 4
	3.4.1 Erosion Hazard Areas..... 4
	3.4.2 Landslide Hazard Areas 4
	3.4.3 Volcanic Hazard Areas..... 5
	3.4.4 Seismic Hazard Areas 6
3.5	Seismic Site Class 7
4.0	Discussion and Recommendations 7
4.1	General 7
4.2	Site Preparation and Grading 8
4.3	Surcharge Program..... 9
4.4	Excavations 10
4.5	Foundations 11
4.6	Slab on Grade Floors..... 12
4.7	Lateral Earth Pressures for Wall Design 12
4.8	Stormwater Detention Vaults 13
4.9	Drainage 13
4.10	Utilities..... 14
4.11	Pavements 15
5.0	Additional Services 16
6.0	Limitations 16

Figures

Vicinity Map.....	Figure 1
Exploration Location Plan.....	Figure 2
Settlement Marker Detail.....	Figure 3
Typical Wall Drainage Detail.....	Figure 4

Appendices

Field Exploration and Laboratory Testing.....	Appendix A
Hydrographs.....	Appendix B
Liquefaction Analysis Results.....	Appendix C

Geotechnical Report PSE Operational Training Center 325 Todd Road Northwest Puyallup, Washington

1.0 PROJECT DESCRIPTION

The project consists of developing the approximately six-acre one parcel property with a PSE Operational Training Center (OTC) along with associated infrastructure improvements. Review of the site plan prepared by Zervas Architects, dated July 21, 2023, shows the OTC building centrally located on the property with a floor area of approximately 33,800 square feet. The area west of the building is designated for outdoor training and includes two smaller buildings, covered areas, burn pit, substation yard and other training features. Design elevations in this western outdoor training area will require raising site grades by placing five to six feet of fill material. Design elevations in the central building and paved eastern site areas are near existing with cuts and fills required to achieve design grades of less than two feet.

The main central building will be a timber framed structure with the western smaller training building steel framed. Both buildings will have their floors constructed at grade. We anticipate structural loading will be relatively light with columns carrying 50 to 75 kips and continuous bearing walls carrying 2 to 4 kips per lineal foot. Loading on the floor slab is not expected to exceed 200 pounds per square foot (psf).

Stormwater will be collected and conveyed to a below grade stormwater detention facility located in the eastern portion of the site. The vault floor will be constructed at approximately elevation 29 feet. When considering the thickness of the vault foundation, this design elevation will require an excavation approaching 20 feet below existing site grades.

The recommendations in the following sections of this report are based on our understanding of the design features outlined above. We should review design drawings as they become available to verify that our recommendations have been properly interpreted and to supplement them, if required.

2.0 SCOPE OF WORK

Our scope of work was completed in accordance with our authorized proposal, dated October 6, 2022. On November 16 and 17, 2022, we observed soil and groundwater conditions at the site by drilling 13 test borings advanced with a hollow-stem auger to depths ranging from approximately 10 to 30 feet below existing site grades. On November 18, 2022, two cone penetration tests (CPTs) were advanced at the site by In Situ Engineering, under subcontract with our office to maximum depths of approximately 60 to 70 feet below existing surface grades. In addition, seismic shear wave testing was completed at one of the CPT locations. Using this data, we performed analyses to develop geotechnical engineering recommendations for project design and construction. Specifically, this report addresses the following:

- Soil and groundwater conditions.
- Geologic hazards per the City of Puyallup Municipal Code (KCC).
- Site preparation and grading.
- Building preload/surcharge program.
- Excavations.
- Foundations.
- Floor slabs at grade.
- Lateral earth pressures for wall design.
- Stormwater facilities.
- Subsurface drainage.
- Utilities.
- Pavements.

It should be noted that recommendations outlined in this report regarding drainage are associated with soil strength, design earth pressures, erosion, and stability. Design and performance issues with respect to moisture as it relates to the structure environment is beyond Terra Associates' purview. A building envelope specialist or contractor should be consulted to address these issues, as needed.

3.0 SITE CONDITIONS

3.1 Surface

The site is located north and east of the intersection of Todd Road Northwest and 4th Street Northwest in Puyallup, Washington. The site is bounded by a railroad along the northeast. The site location is shown on the attached Vicinity Map, Figure 1.

The eastern parcel is currently partially developed and used as a storage yard. The western parcel is not developed and is largely an open grass-covered field. Site topography is relatively flat with no obvious signs of sloping.

3.2 Subsurface

The soil conditions observed at the exploration locations generally consisted of native alluvial sediments composed of alternating and interbedded layers of soft to stiff silt to clayey silt, and very loose to medium dense sand to silty sand. Trace, small organic fragments were observed in several samples obtained from the test borings.

Below a depth of approximately 15 feet beneath existing surface grades, the relative density of the sand deposits becomes medium dense to very dense as indicated by some of the test borings and the deeper CPT data. The CPT data also indicate that the alluvial sediments become predominately fine-grained below a depth of approximately 45 feet beneath existing surface grades, composed of soft to stiff silt to clayey silt deposits. CPT-2 indicates the presence of medium dense to very dense sand deposits underlying the predominant silt deposits at a depth of approximately 67 feet below existing surface grades.

The exceptions to this general condition were observed at Test Borings B-7, B-8, B-9, B-12, and B-13. In Test Boring B-7, we observed numerous organic peat inclusions at a depth of approximately 10 feet. The sample obtained at approximately 20 feet in Test Boring B-9 consisted of a partially decomposed tree trunk. We observed up to approximately four feet of fill material in Test Borings B-8, B-12, and B-13 composed of loose to medium dense gravel with silt and sand to silty gravel with sand.

The *Geologic Map of the Tacoma 1:100,000-Scale Quadrangle, Washington*, by J.E. Schuster, A.A. Cabibbo, J.F. Schilter, and I.J. Hubert (2015) maps the site as Alluvium (Qa). This map unit is consistent with the native soils observed in our field explorations.

The United States Department of Agriculture Natural Resources Conservation Service (NRCS) classifies the onsite soils as Pilchuck fine sand, Puyallup fine sandy loam, and Sultan silt loam materials. A soil horizon, consisting of these materials, is typically deposited by alluvial processes in the form of flood plains and is derived from alluvium deposited by the Puyallup River which is consistent with our exploratory findings and knowledge of the area's geologic setting.

The preceding discussion is intended to be a brief review of the soil conditions observed at the site. More detailed descriptions are presented on the Test Boring Logs and CPT Logs attached in Appendix A. The approximate locations of the Test Boring and CPTs are shown in attached Figure 2.

3.3 Groundwater

The site is underlain by a regional groundwater table residing in the alluvial sediments. Based on observations during drilling and measurements obtained from installed groundwater monitoring wells, groundwater was located at a depth of approximately 4.5 feet below existing grades in the western portion of the site to approximately 10 feet below existing grades in the eastern portion of the site at the time of our November exploration. Given the time of year our field work was completed, and our experience with groundwater conditions in the area, the groundwater levels observed during drilling likely represent near seasonal low levels.

To evaluate the seasonal weather influence, Test Borings B-11 and B-13 were converted to groundwater monitoring wells. The monitoring wells were instrumented with automatic level loggers. Based on data collected from December 2022 through March 29, 2023, this seasons high groundwater was recorded at a depth of 7.2 feet at Test Boring B-11 and 8 feet at Test Boring B-13. The fluctuation of the groundwater levels over the course of the study is shown in hydrographs presented in Appendix B of this report.

When referenced to existing surface elevations, the groundwater table is at approximately elevation 39 feet at Test Boring B-13 and 38.8 feet at Test Boring B-11. This indicates a slight approximately .1 percent groundwater flow gradient to the west. Projecting this gradient to western area of the site indicates the groundwater table would be around elevation 38.4 feet or about two to three feet below grade in this lower elevated portion of the site.

3.4 Geologically Hazardous Areas

Section 21.06.1210(1) of the City of Puyallup Municipal Code (PMC) defines geologic hazards as "...areas susceptible to erosion, landsliding, earthquake, volcanic activity or other potentially hazardous geological processes. Areas susceptible to these types of hazards are hereby designated as geologically hazardous areas and subject to the provisions of this chapter." We have evaluated the site for these hazards in the following sections below.

3.4.1 Erosion Hazard Areas

Section 21.06.1210(3)(a) of the PMC defines erosion hazard areas as "...areas identified by the U.S. Department of Agriculture's Natural Resources Conservation Service or identified by a special study as having a "moderate to severe," "severe," or "very severe" erosion potential."

The soils observed on the site are classified as Pilchuck fine sand, Puyallup fine sandy loam, and Sultan silt loam by the United States Department of Agriculture Natural Resources Conservation Service (NRCS). Over the site with existing gradients, these soils will have a slight susceptibility to erosion when exposed. Therefore, the site does not present an erosion hazard per the PMC. Regardless, the site soils would be susceptible to some erosion when exposed during construction. In our opinion, proper implementation, and maintenance of Best Management Practices (BMPs) for erosion prevention and sediment control would adequately mitigate the erosion potential in the planned development area. Erosion protection measures as required by the City of Puyallup will need to be in place prior to and during grading activities at the site.

3.4.2 Landslide Hazard Areas

Section 21.06.1210(3)(b) of the PMC defines landslide hazard areas as "...areas subject to landslides based on a combination of geologic, topographic, and hydrologic factors. They include any areas susceptible to landslide because of any combination of bedrock, soil, slope (gradient), slope aspect, structure, hydrology, or other factors, and include, at a minimum, the following:

(i) Areas of historic failures, such as:

(A) Those areas delineated by the United States Department of Agriculture Natural Resources Conservation Service as having a significant limitation for building site development;

(B) Those coastal areas mapped as class u (unstable), uos (unstable old slides), and urs (unstable recent slides) in the Department of Ecology Washington coastal atlas; or

- (C) Areas designated as quaternary slumps, earthflows, mudflows, lahars, or landslides on maps published by the United States Geological Survey or Washington Department of Natural Resources.
- (ii) Areas with all three of the following characteristics:
- (A) Slopes steeper than 15 percent;
 - (B) Hillsides intersecting geologic contacts with a relatively permeable sediment overlying a relatively impermeable sediment or bedrock; and
 - (C) Springs or groundwater seepage.
- (iii) Areas that have shown movement during the holocene epoch (from 10,000 years ago to the present) or which are underlain or covered by mass wastage debris of this epoch;
- (iv) Slopes that are parallel or subparallel to planes of weakness (such as bedding planes, joint systems, and fault planes) in subsurface materials;
- (v) Slopes having gradients steeper than eighty percent subject to rockfall during seismic shaking;
- (vi) Areas potentially unstable as a result of rapid stream incision, stream bank erosion, and undercutting by wave action, including stream channel migration zones;
- (vii) Areas that show evidence of, or are at risk from snow avalanches;
- (viii) Areas located in a canyon or on an active alluvial fan, presently or potentially subject to inundation by debris flows or catastrophic flooding; and
- (ix) Any area with a slope of 40 percent or steeper and with a vertical relief of 10 or more feet except areas composed of bedrock. A slope is delineated by establishing its toe and top and measured by averaging the inclination over at least 10 feet of vertical relief.”

As stated above, the site’s topography is relatively flat with no obvious signs of sloping. There are no landslide hazard areas on or near the site.

3.4.3 Volcanic Hazard Areas

Section 21.06.1210(3)(d) of the PMC defines volcanic hazard areas as “...areas subject to pyroclastic flows, lava flows, debris avalanche, inundation by debris flows, lahars, mudflows, or related flooding resulting from volcanic activity. Volcanic hazard areas shall be classified as Case I or Case II lahars per the definitions in PMC 21.06.210. Pyroclastic-flow hazard zones and inundation zones for Case I and II lahars are identified in the report Sedimentology, Behavior, and Hazards of Debris Flows at Mount Rainier, Washington, U.S. Geological Survey Professional Paper 1547, 1995. All volcanic hazard areas regulated under this code are located within lahar time travel zone 3.”

The site is located within the Mount Rainier lahar hazard zone as shown on the USGS Mt. Rainier Lahar Hazard Map, dated November 9, 2016. Given the distance from Mt. Rainier and the general absence of pervasive lahar deposits observed in the CPTs and test borings, it is our opinion that the site meets the definition of a Case I volcanic hazard area per the PMC.

3.4.4 Seismic Hazard Areas

Section 21.06.1210(3)(c) of the PMC defines seismic hazard areas as "... areas subject to severe risk of damage as a result of earthquake-induced ground shaking, slope failure, settlement or subsidence, soil liquefaction, or tsunamis. Settlement and soil liquefaction conditions occur in areas underlain by cohesionless, loose, or soft-saturated soils of low density, typically in association with a shallow ground water table."

Liquefaction is a phenomenon where there is a reduction or complete loss of soil strength due to an increase in water pressure induced by vibrations. Liquefaction mainly affects geologically recent deposits of fine-grained sands underlying the groundwater table. Soils of this nature derive their strength from intergranular friction. The generated water pressure or pore pressure essentially separates the soil grains and eliminates this intergranular friction; thus, eliminating the soil's strength.

The site is mapped as having a high susceptibility to soil liquefaction on the Washington Department of Natural Resources *Natural Hazards Single-Topic Map*.

Based on the soil and groundwater conditions observed at the site, we expected that the site soils would have the potential to liquefy. Therefore, we completed an analysis of soil liquefaction potential incorporating field soil strength values and soil types determined from the CPT's. An assumed depth to groundwater of five feet was used in the analysis based on depths to groundwater measured in the monitoring wells prior to the wet season. The analysis is based on a Magnitude 7 earthquake inducing ground motions having a peak ground acceleration (PGA) value of 0.5g. This acceleration represents an earthquake with a 2 percent probability of exceedance in 50 years.

The results of our analysis indicate soil liquefaction could occur during the design earthquake event, resulting in total settlements approaching approximately three-and-one-half to five inches, with one-half of that settlement likely being differential in nature. Results of the analysis are attached in Appendix C.

In our opinion, the potential settlement is borderline regarding structural impairment and should be reviewed by the project structural engineer. If the owner is not willing to accept the risk of building damage, requiring repair, should liquefaction-induced settlements occur, or if the structural engineer cannot design the structure to meet all governing life safety codes, including the life safety provisions of the current International Building Code, foundations should be supported on ground improved using vibrated stone columns designed to mitigate soil liquefaction settlements.

3.5 Seismic Site Class

As discussed, soil conditions at the site will be subject to the soil liquefaction phenomenon. Because of this condition, per the current International Building Code (IBC), subsurface conditions would be assigned Site Class “F”, which would require performing a site-specific seismic analysis to determine seismic forces for structural design. However, the IBC allows for using code derived seismic values for the soil conditions indicated if the buildings fundamental period is equal to or less than .5 seconds. We expect that this building will fall into this category. In this case, based on soil conditions encountered, Site Class “E” can be used to determine seismic design forces.

4.0 DISCUSSION AND RECOMMENDATIONS

4.1 General

Based on our study, development of the site as proposed is feasible from a geotechnical engineering standpoint. The primary geotechnical concern at the site is the presence of soil strata susceptible to consolidation under the planned building loads. The compressible soils consist of layers of very soft to stiff silt, in addition to collections and inclusions of organic peat, that vary in thickness across the site. These soils are compressible and, if not mitigated, will likely cause unacceptable levels of differential building settlement under expected static building loads.

Given the depth to the compressible silt layers, in our opinion, the potential post-construction building settlements can be mitigated by implementing a surcharge program. This would entail raising site grades to finish floor elevation and then placing an additional depth of surcharge fill for a period of time to induce settlements prior to application of building loads. Building construction can begin after completion of the surcharge program.

The building can be supported on conventional spread footings bearing on a minimum of two feet of structural fill. Depending upon final building grades, the existing granular fill observed at Test Borings B-8 and B-12, located in the eastern developed storage yard area, could serve as this structural fill layer provided it is re-compacted to achieve structural fill compaction requirements. The building floor and exterior pavements can be similarly supported.

If building schedules do not allow for a surcharge program to take place, or if the owner is unwilling to or cannot accept the risk of seismically induced building settlement, the building can be supported on ground improved by installing vibrated stone columns. If completed over the entire building footprint, this would preclude the need for a fill surcharge program. If stone columns are only used to improve ground conditions below building footings, surcharging to mitigate potential floor slab settlement is recommended.

The majority of the native and existing fill soils observed at the site contain a significant amount of fines and will be difficult to compact as structural fill when too wet. The ability to use native soil soils from site excavations as structural fill will depend upon its moisture content and the prevailing weather conditions at the time of construction.

If grading activities will take place during winter, the owner should be prepared to import clean granular material for use as structural fill and backfill. Alternatively, stabilizing the moisture in the native and existing fill soils with cement or lime can be considered.

Detailed recommendations regarding these issues and other geotechnical design considerations are provided in the following sections. These recommendations should be incorporated into the final design drawings and construction specifications.

4.2 Site Preparation and Grading

To prepare the site for construction, all vegetation and organic surface soils should be stripped and removed from the site. We expect surface stripping depths of about three to six inches will be required to remove the organic surficial soils. Organic soils will not be suitable for use as structural fill but may be used for limited depths in nonstructural areas or for landscaping purposes.

Demolition of existing structures should include removal of existing foundations and other buried utilities. Abandoned utility pipes that fall outside of new building areas can be left in place provided they are sealed to prevent intrusion of groundwater seepage and soil.

Prior to fill placement or construction of building foundations or site pavements, we recommend all exposed subgrade surfaces be observed by a representative of Terra Associates, Inc. to verify soil conditions are as expected and suitable for support. The contractor should be prepared to proofroll subgrade areas with heavy construction equipment to assist in evaluating the suitability of the bearing subgrade. If excessively yielding areas are observed and cannot be stabilized in place by compaction, the affected soils should be excavated and removed to firm bearing and grade restored with new structural fill. If the depth of excavation to remove unstable soils is excessive, use of a geotextile reinforcing/separation fabric, such as Mirafi 600X or equivalent, can be considered in conjunction with structural fill. Our experience has shown that, in general, a minimum of 18 to 24 inches of a clean, granular structural fill over the geotextile fabric should establish a stable bearing surface.

All building footings should obtain support on a minimum of two feet of granular structural fill, extending at least one foot laterally from the edge of footing. As discussed earlier, the existing granular fill observed at Test Borings B-8 and B-12 located in the eastern developed storage yard area, could serve as this structural fill layer provided it is re-compacted to achieve structural fill compaction requirements.

The majority of the native and existing fill soils observed at the site contain a sufficient percentage of fines (silt and clay size particles), which will make them difficult to re-compact as structural fill if they are too wet or too dry. Accordingly, the ability to use the soils from site excavations as structural fill will depend upon their moisture content and the prevailing weather conditions when site grading activities take place. Soils that are too wet to properly compact can be dried by aeration during dry weather conditions. Alternatively, treatment with cement or lime can be considered. If additives are used, additional Best Management Practices (BMPs) will need to be implemented to mitigate potential impacts to construction stormwater runoff.

If grading activities are planned during the wet winter months, or if they are initiated during the summer and extend into fall and winter, the contractor should be prepared to import wet weather structural fill. For this purpose, we recommend importing a granular soil that meets the following grading requirements:

U.S. Sieve Size	Percent Passing
6 inches	100
No. 4	75 maximum
No. 200	5 maximum*

*Based on the 3/4-inch fraction.

Prior to use, Terra Associates, Inc. should examine and test all materials imported to the site for use as structural fill.

Structural fill should be placed in uniform loose layers not exceeding 12 inches and compacted to a minimum of 95 percent of the soil's maximum dry density, as determined by American Society for Testing and Materials (ASTM) Test Designation D-1557 (Modified Proctor). The moisture content of the soil at the time of compaction should be within two percent of its optimum, as determined by this ASTM standard. In nonstructural areas, the degree of compaction can be reduced to 90 percent.

4.3 Surcharge Program

We recommend surcharging the building area to limit building foundation and floor slab settlements to tolerable levels. For this procedure, we recommend placing structural fill in the building areas to the design floor elevation and then placing an additional four-foot depth of surcharge fill. The surcharge fill should extend a minimum of two feet beyond the building perimeter footing edge. This surcharge fill does not need to meet any special requirements other than having a minimum in-place unit weight of 120 pounds per cubic foot (pcf). However, it may be advisable to use a good quality fill to raise grades in other portions of the site, such as parking and driveway areas, if necessary.

In the western pavement areas where five to six feet of fill is required to establish design grades, the recommended full surcharge depth is not required. Here we recommend placing fill to the design final pavement elevation and allowing settlement under this fill loading to occur prior to pavement or utility construction.

Total settlement under the surcharge fill is estimated in the range of four to six inches. These settlements are expected to occur in about four to six weeks following full application of the building fill.

To verify the amount of settlement and the time rate of movement, the surcharge program should be monitored by installing settlement markers. The settlement markers should be installed on the existing grade prior to placing any building or preload fills. Once installed, elevations of both the fill height and marker should be taken twice weekly until the full height of the surcharge is in place. Once fully surcharged, readings should continue weekly until the anticipated settlements have occurred. A typical settlement marker detail is provided as Figure 3.

It is critical that the grading contractor recognize the importance of the settlement marker installations. All efforts must be made to protect the markers from damage during fill placement. It is difficult, if not impossible, to evaluate the progress of the surcharge program if the markers are damaged or destroyed by construction equipment. As a result, it may be necessary to install new markers and extend the surcharging time period in order to ensure that settlements have ceased and building construction can begin.

Potential long-term settlements due to secondary compression of the peat layers, which cannot be fully mitigated by surcharging, will also occur. The magnitude of this settlement will be greater in the early years diminishing with time. The approximate total settlement due to secondary compression is estimated to be 1.5 to 2 inches in 20 years. Approximately 50 percent of the total secondary settlement may be differential in nature due to the varying thickness of the peat layers. For floor slab design purposes, we estimate these differential settlements will occur over a distance of 100 feet.

4.4 Excavations

All excavations at the site associated with confined spaces, such as utility trenches, must be completed in accordance with local, state, and federal requirements. Based on regulations outlined in the Washington Industrial Safety and Health Act (WISHA), the fill soils would be classified as Type C soil.

Accordingly, temporary excavations in Type C soils should have their slopes laid back at an inclination of 1.5:1 (Horizontal:Vertical) or flatter, from the toe to the crest of the slope. All exposed temporary slope faces that will remain open for more than two days should be covered with a durable reinforced plastic membrane during construction to prevent slope raveling and rutting during periods of precipitation. If there is insufficient room to slope, the temporary excavation sides shoring will be required. Properly designed and installed shoring trench boxes can be used to support utility trench excavations where required.

Based on our study, groundwater should be anticipated within excavations extending below depths of about three to seven feet below existing site grades during the wet winter months. Excavations extending below these depths will likely encounter groundwater with volumes and flow rates sufficient to require some level of dewatering. Shallow excavations that do not extend more than two feet below the groundwater table can likely be dewatered by conventional sump-pumping procedures along with a system of collection trenches. Deeper excavation as is expected for construction of the stormwater detention facility will require dewatering by well points or isolated deep-pump wells. The dewatering system should be designed and installed by an experienced dewatering contractor.

This information is provided solely for the benefit of the owner and other design consultants and should not be construed to imply that Terra Associates, Inc. assumes responsibility for job site safety. It is understood that job site safety is the sole responsibility of the project contractor.

4.5 Foundations

In our opinion, following the successful implementation of the surcharge program, the buildings can be supported on conventional spread footing foundations bearing on structural fill as recommended in the Site Grading and Preparation section of this report. However, if the owner is not willing to accept the risk for building damage due to the potential for liquefaction induced settlements during an earthquake or it is determined that the estimated liquefaction settlements would preclude design of the structure the building shell to meet all governing life safety codes, including the life safety provisions of the current International Building Code, the building foundations should be supported on ground improved using vibrated stone columns designed to mitigate soil liquefaction settlements.

Spread Footings

In our opinion, following the completion of a successful surcharge program as outlined in Section 4.3, the building may be supported on conventional spread footing foundations. As noted, all foundations must be supported on a minimum of two feet of structural fill that extends laterally beyond the edge of the footing a minimum distance of one foot. Structural fill used for support of footings should consist of a granular import material meeting the grading recommendations for a wet weather structural fill.

Foundations exposed to the weather should bear at a minimum depth of one and one-half feet below adjacent exterior grades for frost protection. Interior foundations should be supported at a minimum depth of one foot below the finished floor elevation.

We recommend designing foundations for a net allowable bearing capacity of 2,500 psf. For short-term loads, such as wind and seismic, a one-third increase in this allowable capacity can be used. With the expected building loads and this bearing stress applied, in general, total, and differential settlements should not exceed one inch and one-half inch, respectively. The differential settlement is expected to occur between perimeter wall and interior column locations.

For designing foundations to resist lateral loads, a base friction coefficient of 0.35 can be used. Passive earth pressures acting on the sides of the footings should be considered. We recommend calculating this lateral resistance using an equivalent fluid weight of 300 pounds per cubic foot (pcf). We do not recommend including the upper 12 inches of soil in this computation because it can be affected by weather or disturbed by future grading activity. This value assumes the foundation will be backfilled with structural fill, as described in Section 4.2 of this report. The values recommended include a safety factor of 1.5.

Ground Improvement

As noted earlier if the owner is unwilling to accept the risk of building damage due to liquefaction settlement, the building can be supported on ground improved using vibrated stone columns specifically designed to mitigate liquefaction settlement to tolerable levels. This method creates highly densified columns of graded aggregate that would extend through the upper loose and soft to medium stiff soils into the underlying medium dense to dense sand deposits. Due to the methods used to construct the columns, some improvement of the adjacent soils is also realized.

Moreover, these methods can provide liquefaction mitigation by providing drainage paths and reduced pore pressures during ground shaking, and by constructing stiff, non-liquefiable inclusions in the soils. Once constructed, conventional spread footing foundations can be designed to bear immediately above the stone columns.

These ground improvement techniques are typically completed on a design/build approach with both design and construction completed by a geotechnical specialty contractor. We can assist in contacting and selecting the specialty contractor, if desired.

4.6 Slab on Grade Floors

Suitable support for slab on grade floors will be provided by subgrade prepared as recommended in Section 4.2 of this report following implementation of the surcharge program. Immediately below the floor slab, we recommend placing a four-inch-thick capillary break layer composed of clean, coarse sand or fine gravel that has less than three percent passing the No. 200 sieve. This material will reduce the potential for upward capillary movement of water through the underlying soil and subsequent wetting of the floor slab.

The capillary break layer will not prevent moisture intrusion through the slab caused by water vapor transmission. Where moisture by vapor transmission is undesirable, such as covered floor areas, a common practice is to place a durable plastic membrane on the capillary break layer and then cover the membrane with a layer of clean sand or fine gravel to protect it from damage during construction, and aid in uniform curing of the concrete slab. It should be noted that if the sand or gravel layer overlying the membrane is saturated prior to pouring the slab, it will be ineffective in assisting uniform curing of the slab and can actually serve as a water supply for moisture transmission through the slab that affects floor coverings. Therefore, in our opinion, covering the membrane with a layer of sand or gravel should be avoided if floor slab construction occurs during the wet winter months and the layer cannot be effectively drained. We recommend floor designers and contractors refer to the updated American Concrete Institute (ACI) Manual of Concrete Practice for further information regarding vapor barrier installation below slab-on-grade floors.

With the floor subgrade prepared as recommended, a subgrade modulus (k_s) value of 100 pounds per square inch per inch of deflection (pci) can be used in design of the building floor slabs subject to heavy lift truck traffic.

4.7 Lateral Earth Pressures for Wall Design

The magnitude of earth pressure development on retaining walls partly depend upon the quality of wall backfill. Where fill is placed behind retaining walls, we recommend placing and compacting it as structural fill. The fill should be compacted to a minimum of 90 percent of its maximum dry unit weight as determined by ASTM Test Designation D-1557 (Modified Proctor). To guard against the build-up of hydrostatic pressure, wall drainage must also be installed. We recommend that wall drainage consist of a minimum 12-inch-thick layer of washed gravel placed adjacent to the wall. Alternatively, a composite drainage panel such as Mirafi G100N or equal can be used. A four-inch diameter perforated pipe should be placed on a bed of gravel along the base of the wall footing and directed to a suitable outlet. A typical wall drainage detail is attached as Figure 4.

With granular backfill placed and compacted as recommended and drainage properly installed, we recommend designing restrained (not free to deflect) retaining walls for an at-rest earth pressure equivalent to a fluid weighing 50 pcf. A value of 35 pcf may be used for the case where the wall is unrestrained. These values do not include other surcharge loading such as from fill backslopes or adjacent footings that may act on the wall. If such conditions exist, then the imposed loading must be included in wall design. Values of friction at the base of wall foundations and passive earth pressure that are used in design to resist lateral loads are provided in Section 4.5 of this report.

4.8 Stormwater Detention Vault

With the eastern detention vault foundation bearing at a depth of 15 to 20 feet below existing site grades, soils that will likely be exposed will consist of medium dense fine to medium sand. These sands will be suitable for support of the detention vault and no over excavation and replacement with crushed rock would be required for bearing purposes. For constructability however, it would be advisable to construct a working mat to avoid excessive disturbance of the native sand subgrade. For this purpose, we recommend over-excavating the by 6-inches and restoring grade with clean 1 ¼-inch to 2-inch crushed rock. Additionally, any organic peat or organic inclusions exposed should be removed to expose competent native soils. Vault foundations supported in this manner can be designed for an allowable bearing capacity of 2,500 psf. For short-term loads, such as seismic, a one-third increase in this allowable capacity can be used.

Vault walls should be designed as below-grade retaining walls following the parameters outline in Section 4.7 of this report. Any portion of the wall for which drainage cannot be provided should be designed for an earth pressure equivalent to a fluid weighing 85 pcf. Where applicable, a uniform horizontal traffic value of 75 psf should be included in the design of vault walls.

The detention vault will be subject to uplift pressures if drainage is not provided for the detention vault walls. For design, uplift forces should be based on a groundwater elevation equal to elevation 40 feet. The weight of the structure and the weight of the soil above its foundation will provide resistance to uplift. A soil unit weight of 125 pcf can be used in designing the structure to resist uplift forces.

4.9 Drainage

Infiltration Feasibility

In general, based on the shallow seasonal water table and the fine-grained nature of the soils observed across the site, it is our opinion that infiltration should not be relied on to manage development stormwater runoff on a whole scale basis. Conventional stormwater detention with controlled release should be used to manage a majority of the stormwater runoff.

It may be feasible to use low impact development (LID) features such as shallow bioretention cells or permeable pavements for managing a minor component of the runoff. Bioretention cells could be considered along the northern margin of the site where shallow soil conditions generally consist of silty sand and sand with silt with a few silt seams. Designing these elements with an infiltration component equivalent to .2 inches per hour would be feasible in our opinion. Permeable concrete pavement could also be considered across the site with design based on an infiltration rate of .05 inches per hour.

Surface

Final exterior grades should promote free and positive drainage away from the building areas. We recommend providing a gradient of at least three percent for a minimum distance of ten feet from the building perimeter, except in paved locations. In paved locations, a minimum gradient of two percent should be provided, unless provisions are included for collection and disposal of surface water adjacent to the structures.

Subsurface

Foundation drains should be installed where floor slab wetness or interior moisture due to water vapor is not desired. Where foundation drainage is installed, we recommend it consist of four-inch diameter perforated PVC pipe that is enveloped in washed ½- to ¾-inch gravel-sized drainage aggregate. The aggregate should extend six inches above and to the sides of the pipe. The foundation drains and roof downspouts should be tightlined separately to an approved point of controlled discharge.

4.10 Utilities

Utility pipes should be bedded and backfilled in accordance with American Public Works Association (APWA), or City of Puyallup specifications. As a minimum, trench backfill should be placed and compacted as structural fill, as described in Section 4.2 of this report. As noted, the existing fill and native soils are moisture sensitive and close moisture control will be required to facilitate proper compaction. If utility construction takes place during the wet winter months, it will likely be necessary to import suitable wet weather fill for utility trench backfilling.

The utility contractor should also be prepared for encountering unstable loose native soils below the pipe invert elevations. If not removed from below the pipe and replaced with crushed rock or additional bedding material, pipe deflections may occur as a result of the soil yielding and compressing in response to loading imposed during trench backfilling. The need to over-excavate and stabilize the pipe foundation before backfilling should be evaluated by observation and testing during construction.

4.11 Pavements

Pavement subgrades should be prepared as described in Section 4.2 of this report. Regardless of the degree of relative compaction achieved, the subgrade must be firm and relatively unyielding before paving. The subgrade should be proof rolled with heavy rubber-tired construction equipment such as a loaded 10-yard dump truck to verify this condition.

The pavement design section is dependent upon the supporting capability of the subgrade soils and the traffic conditions to which it will be subjected. New pavements for the project will consist of drive aisles accessing parking spaces and storage areas. Accordingly, we expect traffic will consist of cars and light trucks, along with heavy traffic in the form of tractor-trailer rigs. For design considerations, we have assumed traffic in parking and in car/light truck access pavement areas can be represented by an 18-kip Equivalent Single Axle Loading (ESAL) of 50,000 over a 20-year design life. For heavy traffic pavement areas, we have assumed an ESAL of 300,000 would be representative of the expected loading. These ESALs represent loading approximately equivalent to 3 and 18, loaded (80,000-pound GVW) tractor-trailer rigs traversing the pavement daily in each area, respectively. If higher truck traffic volumes are expected, we should be notified and asked to review and revise the following pavement recommendations, as needed.

With a stable subgrade prepared as recommended, we recommend the following options for pavement sections:

Light traffic and parking:

- Two inches of hot mix asphalt (HMA) over four inches of crushed rock base (CRB).
- Full depth HMA – four inches.

Heavy traffic:

- Three inches of HMA over eight inches of CRB.
- Full depth HMA – six inches.

For exterior Portland cement concrete (PCC) pavement, we recommend the following:

- Six inches of PCC over two inches of CRB.
 - 28-day compressive strength – 4,000 psi.
 - Control joints spaced at a maximum of 15 feet.

Soil cement stabilization or constructing a soil cement base for support of the pavement section can also be considered as an alternative to the above conventional pavement sections. Assuming a properly constructed soil cement base having a minimum thickness of 12 inches and a minimum seven-day compressive strength of 100 pounds per square inch (psi), a minimum HMA pavement thickness of three inches would be required for the heavy traffic areas. The design of the soil cement base should be completed using samples of the subgrade exposed at the time of construction.

The paving materials used should conform to the Washington State Department of Transportation (WSDOT) specifications for half-inch class HMA, PCC, and CRB.

Long-term pavement performance will depend upon surface drainage. A poorly drained pavement section will be subject to premature failure resulting from surface water infiltrating the subgrade soils and reducing their supporting capability. For optimum performance, we recommend surface drainage gradients of at least two percent. Some degree of longitudinal and transverse cracking of the pavement surface should be expected over time. Regular maintenance should be planned to seal cracks as they occur. In addition, because of long-term secondary compression of the peat material, some subsidence of the pavement surface resulting in depressed bird bath areas should be expected. Above normal maintenance of the pavement requiring repair of failed pavement in these areas should be planned for.

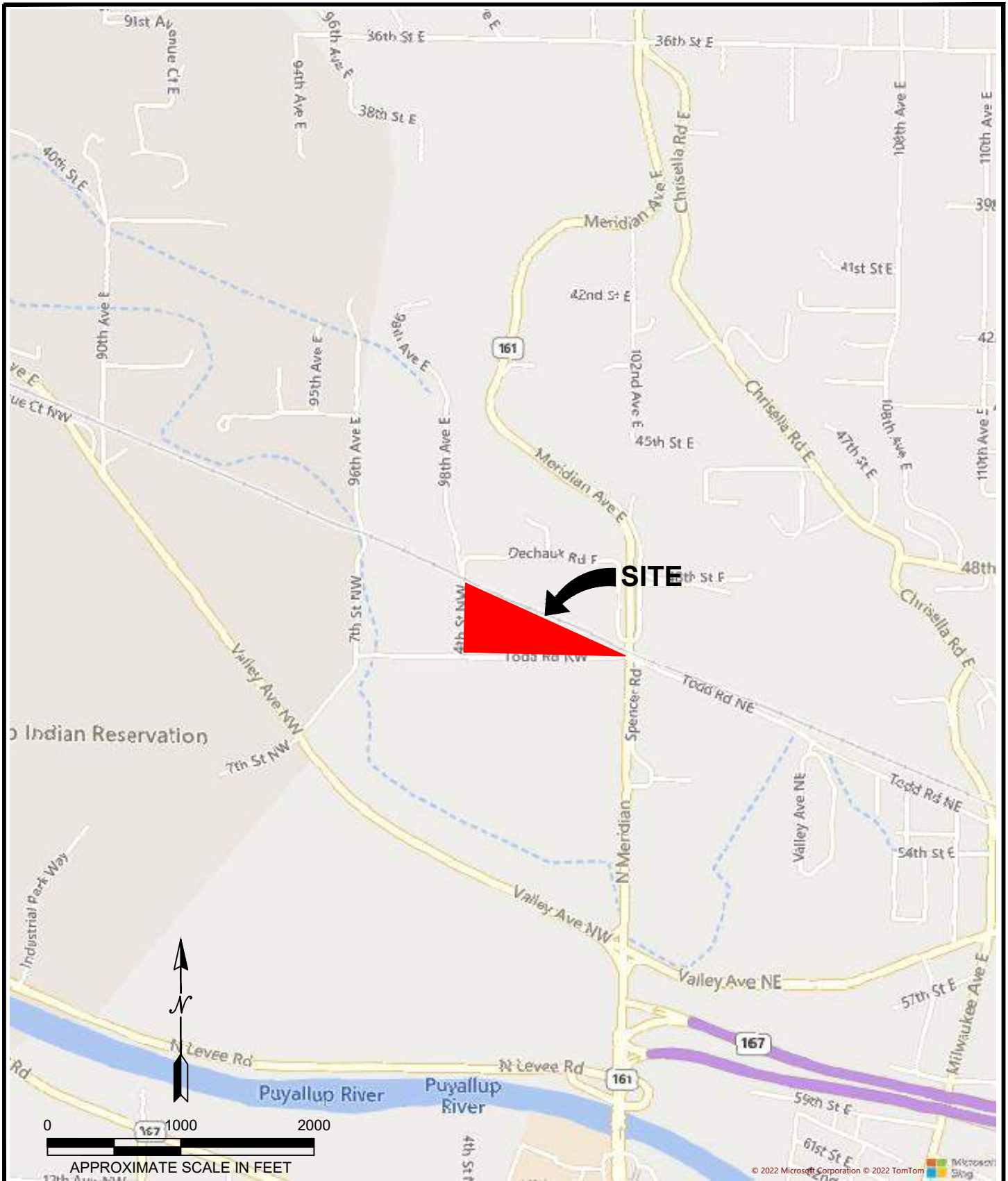
5.0 ADDITIONAL SERVICES

Terra Associates, Inc. should review the final design drawings and specifications in order to verify that earthwork and foundation recommendations have been properly interpreted and implemented in project design. We should also provide geotechnical services during construction to observe compliance with our design concepts, specifications, and recommendations. This will allow for design changes if subsurface conditions differ from those anticipated prior to the start of construction.

6.0 LIMITATIONS

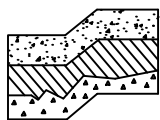
We prepared this report in accordance with generally accepted geotechnical engineering practices. No other warranty, expressed or implied, is made. This report is the copyrighted property of Terra Associates, Inc. and is intended for specific application to the PSE Operational Training Center project in Puyallup, Washington. This report is for the exclusive use of Trammell Crow Company and their authorized representatives.

The analyses and recommendations presented in this report are preliminary in nature and are based on data obtained from the test borings and CPTs completed on the site. Variations in soil conditions can occur, the nature and extent of which may not become evident until construction. If variations appear evident, Terra Associates, Inc. should be requested to reevaluate the recommendations in this report prior to proceeding with construction.



REFERENCE: <https://www.bing.com/maps>

ACCESSED 2023



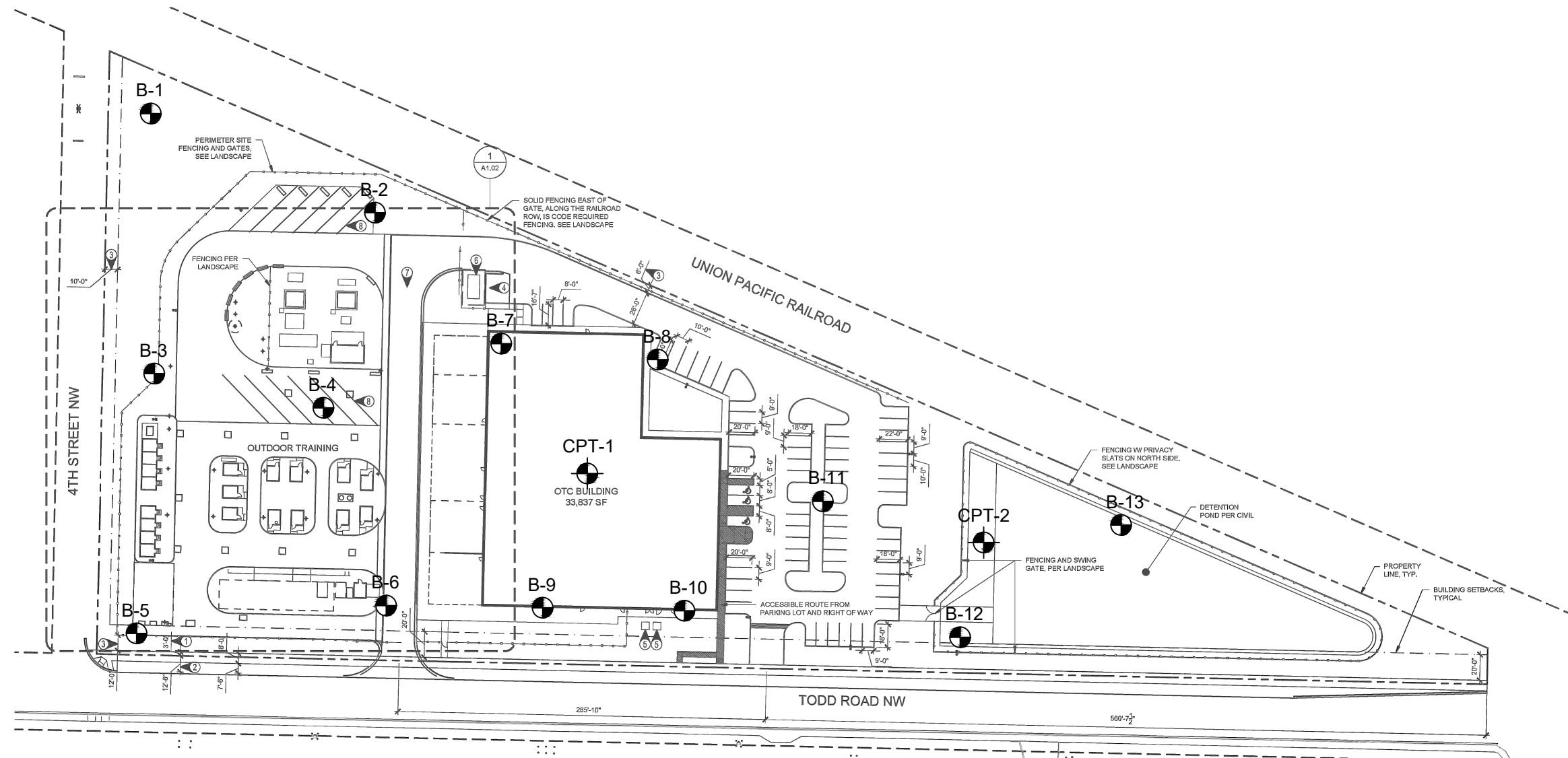
Terra Associates, Inc.
 Consultants in Geotechnical Engineering
 Geology and
 Environmental Earth Sciences

VICINITY MAP
 PSE OPERATION TRAINING CENTER
 PUYALLUP, WASHINGTON

Proj.No. T-8829

Date: AUG 2023

Figure 1





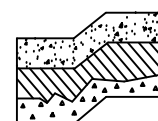
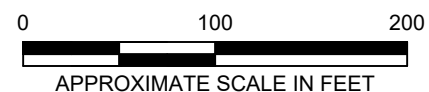
NOTE:

THIS SITE PLAN IS SCHEMATIC. ALL LOCATIONS AND DIMENSIONS ARE APPROXIMATE. IT IS INTENDED FOR REFERENCE ONLY AND SHOULD NOT BE USED FOR DESIGN OR CONSTRUCTION PURPOSES.

REFERENCE: SITE PLAN PROVIDED BY CLIENT.

LEGEND:

-  APPROXIMATE BORING LOCATION
-  APPROXIMATE CONE PENETRATION TEST



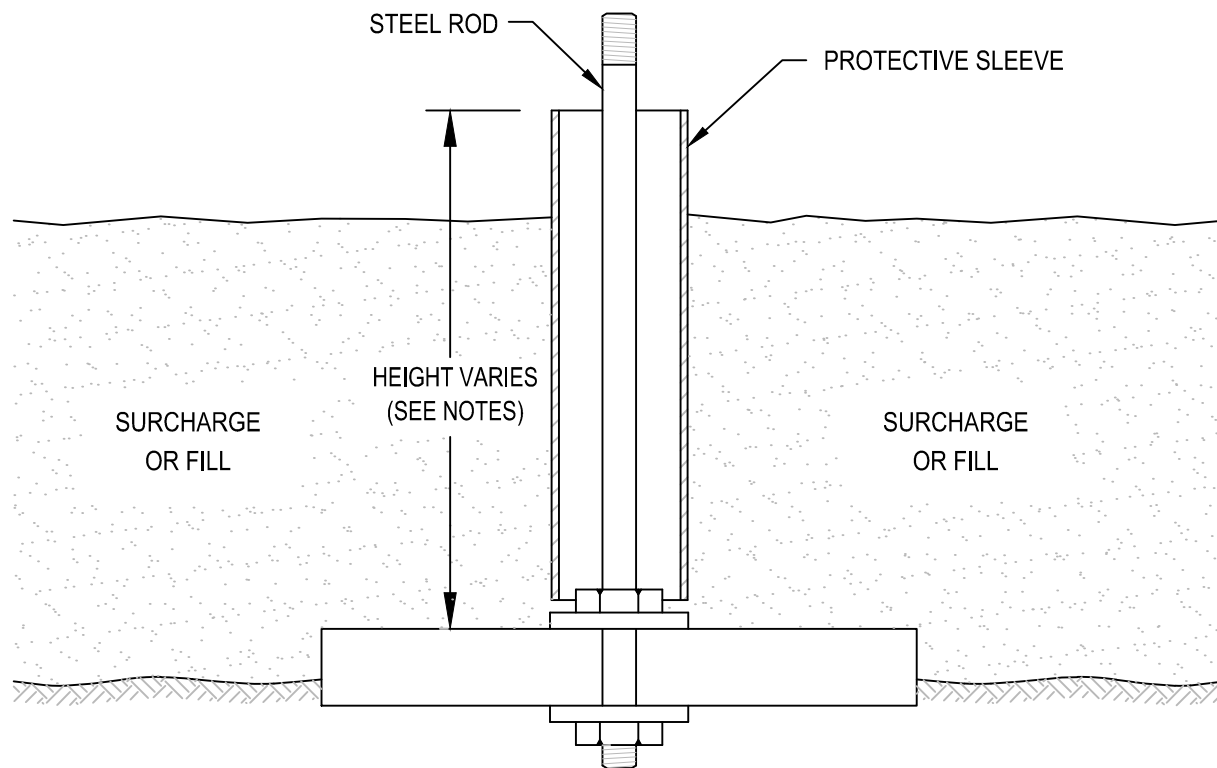
Terra Associates, Inc.
Consultants in Geotechnical Engineering
Geology and
Environmental Earth Sciences

EXPLORATION LOCATION PLAN
PSE OPERATION TRAINING CENTER
PUYALLUP, WASHINGTON

Proj.No. T-8829

Date: AUG 2023

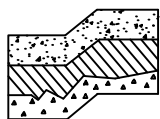
Figure 2



NOT TO SCALE

NOTES:

1. BASE CONSISTS OF 3/4" THICK, 2'x2' PLYWOOD WITH CENTER DRILLED 5/8" DIAMETER HOLE.
2. BEDDING MATERIAL, IF REQUIRED, SHOULD CONSIST OF CLEAN COARSE SAND.
3. MARKER ROD IS 1/2" DIAMETER STEEL ROD THREADED AT BOTH ENDS.
4. MARKER ROD IS ATTACHED TO BASE BY NUT AND WASHER ON EACH SIDE OF BASE.
5. PROTECTIVE SLEEVE SURROUNDING MARKER ROD SHOULD CONSIST OF 2" DIAMETER PLASTIC TUBING. SLEEVE IS NOT ATTACHED TO ROD OR BASE.
6. ADDITIONAL SECTIONS OF STEEL ROD CAN BE CONNECTED WITH THREADED COUPLINGS.
7. ADDITIONAL SECTIONS OF PLASTIC PROTECTIVE SLEEVE CAN BE CONNECTED WITH PRESS-FIT PLASTIC COUPLINGS.
8. STEEL MARKER ROD SHOULD EXTEND AT LEAST 6" ABOVE TOP OF PLASTIC PROTECTIVE SLEEVE.
9. PLASTIC PROTECTIVE SLEEVE SHOULD EXTEND AT LEAST 1" ABOVE TOP OF FILL SURFACE.



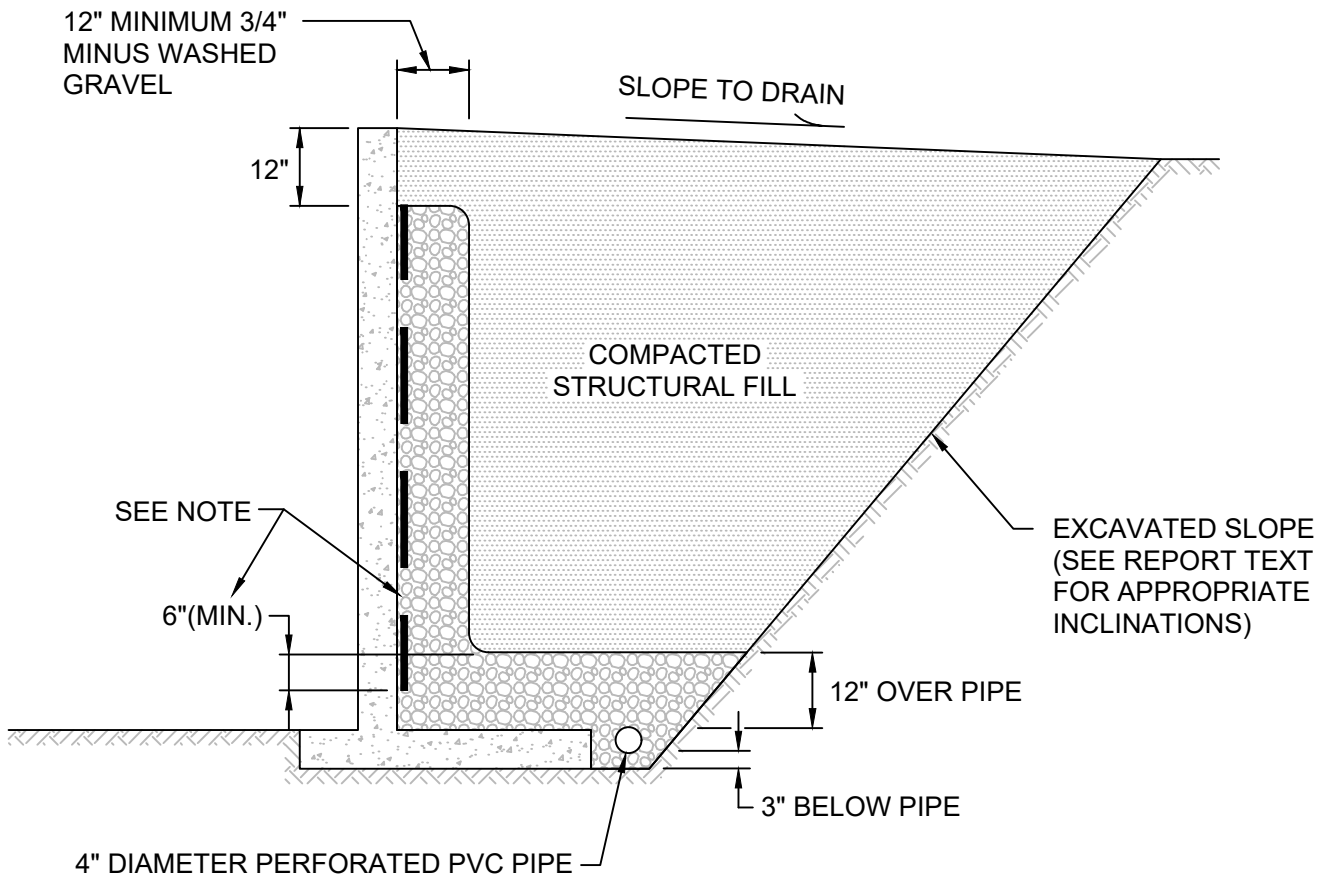
Terra
Associates, Inc.
 Consultants in Geotechnical Engineering
 Geology and
 Environmental Earth Sciences

SETTLEMENT MARKER DETAIL
 PSE OPERATION TRAINING CENTER
 PUYALLUP, WASHINGTON

Proj.No. T-8829

Date: AUG 2023

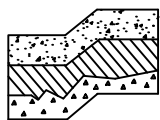
Figure 3



NOT TO SCALE

NOTE:

MIRADRAIN G100N PREFABRICATED DRAINAGE PANELS OR SIMILAR PRODUCT CAN BE SUBSTITUTED FOR THE 12-INCH WIDE GRAVEL DRAIN BEHIND WALL. DRAINAGE PANELS SHOULD EXTEND A MINIMUM OF SIX INCHES INTO 12-INCH THICK DRAINAGE GRAVEL LAYER OVER PERFORATED DRAIN PIPE.



Terra Associates, Inc.
 Consultants in Geotechnical Engineering
 Geology and
 Environmental Earth Sciences

TYPICAL WALL DRAINAGE DETAIL
 PSE OPERATION TRAINING CENTER
 PUYALLUP, WASHINGTON

Proj.No. T-8829

Date: AUG 2023

Figure 4

APPENDIX A
FIELD EXPLORATION AND LABORATORY TESTING

PSE Operational Training Center
Puyallup, Washington

On November 16, 2022, and November 17, 2022, we observed soil conditions at 13 test borings drilled to depths of approximately 10 to 30 feet below existing surface grades. On November 18, 2022, In-Situ Engineering, under subcontract with Terra Associates, Inc., performed 2 cone penetration tests (CPTs). Test boring and CPT locations were determined in the field by measuring from existing site features. The approximate locations of the test borings and CPTs are shown on the attached Exploration Location Plan, Figure 2. Test Boring Logs are attached as Figures A-2 through A-14.




A geotechnical engineer from our office conducted the field exploration. Our representative classified the soil conditions encountered, maintained a log of each test boring, obtained representative soil samples, and recorded water levels observed during drilling. During drilling, soil samples were obtained in general accordance with ASTM Test Designation D-1586. Using this procedure, a 2-inch (outside diameter) split barrel sampler is driven into the ground 18 inches using a 140-pound hammer free falling from a height of 30 inches. The number of blows required to drive the sampler 12 inches after an initial 6-inch set is referred to as the Standard Penetration Resistance value or N value. This is an index related to the consistency of cohesive soils and relative density of cohesionless materials. N values obtained for each sampling interval are recorded on the Test Boring Logs, Figures A-2 through A-14. All soil samples were visually classified in accordance with the Unified Soil Classification System (USCS) described on Figure A-1.

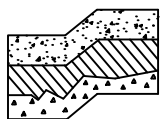
Representative soil samples obtained from the test borings were placed in sealed plastic bags and taken to our laboratory for further examination and testing. The moisture content of each sample was measured and is reported on the Test Boring Logs. Grain size analyses were performed on select soil samples. The results are shown on Figures A-15 and A-16.

InSitu Engineering, under subcontract with Terra Associates, Inc., conducted two electric CPTs at locations selected by Terra Associates, Inc. which are shown in Figure 2. The CPTs were advanced to depths of 60 to 70 feet below the surface. The CPT was instrumented, and an approximately 1.5-inch diameter cone was pushed into the ground at a constant rate. During advancement, continuous measurements are made of the resistance to penetration of the cone and the friction of the outer surface of the sleeve. The cone is also equipped with a porous filter and a pressure transducer for measuring groundwater or pore water pressure generated. Measurements of tip and sleeve frictional resistance, pore pressure, and interpreted soil conditions are summarized in graphical form on the attached CPT Logs.

MAJOR DIVISIONS			LETTER SYMBOL	TYPICAL DESCRIPTION	
COARSE GRAINED SOILS	More than 50% material larger than No. 200 sieve size	GRAVELS More than 50% of coarse fraction is larger than No. 4 sieve	Clean Gravels (less than 5% fines)	GW	Well-graded gravels, gravel-sand mixtures, little or no fines.
				GP	Poorly-graded gravels, gravel-sand mixtures, little or no fines.
			Gravels with fines	GM	Silty gravels, gravel-sand-silt mixtures, non-plastic fines.
				GC	Clayey gravels, gravel-sand-clay mixtures, plastic fines.
	More than 50% of coarse fraction is smaller than No. 4 sieve	SANDS More than 50% of coarse fraction is smaller than No. 4 sieve	Clean Sands (less than 5% fines)	SW	Well-graded sands, sands with gravel, little or no fines.
				SP	Poorly-graded sands, sands with gravel, little or no fines.
			Sands with fines	SM	Silty sands, sand-silt mixtures, non-plastic fines.
				SC	Clayey sands, sand-clay mixtures, plastic fines.
FINE GRAINED SOILS	More than 50% material smaller than No. 200 sieve size	SILTS AND CLAYS Liquid Limit is less than 50%	ML	Inorganic silts, rock flour, clayey silts with slight plasticity.	
			CL	Inorganic clays of low to medium plasticity. (Lean clay)	
			OL	Organic silts and organic clays of low plasticity.	
		SILTS AND CLAYS Liquid Limit is greater than 50%	MH	Inorganic silts, elastic.	
			CH	Inorganic clays of high plasticity. (Fat clay)	
			OH	Organic clays of high plasticity.	
HIGHLY ORGANIC SOILS			PT	Peat.	

DEFINITION OF TERMS AND SYMBOLS

COHESIONLESS	<u>Density</u>	<u>Standard Penetration Resistance in Blows/Foot</u>		2" OUTSIDE DIAMETER SPILT SPOON SAMPLER
	Very Loose Loose Medium Dense Dense Very Dense	0-4 4-10 10-30 30-50 >50		2.4" INSIDE DIAMETER RING SAMPLER OR SHELBY TUBE SAMPLER
COHESIVE	<u>Consistency</u>	<u>Standard Penetration Resistance in Blows/Foot</u>		WATER LEVEL (Date)
	Very Soft Soft Medium Stiff Stiff Very Stiff Hard	0-2 2-4 4-8 8-16 16-32 >32	Tr	TORVANE READINGS, tsf
			Pp	PENETROMETER READING, tsf
			DD	DRY DENSITY, pounds per cubic foot
			LL	LIQUID LIMIT, percent
			PI	PLASTIC INDEX
			N	STANDARD PENETRATION, blows per foot



Terra Associates, Inc.
 Consultants in Geotechnical Engineering
 Geology and Environmental Earth Sciences

UNIFIED SOIL CLASSIFICATION SYSTEM
 PSE OPERATION TRAINING CENTER
 PUYALLUP, WASHINGTON

Proj.No. T-8829

Date: AUG 2023

Figure A-1

LOG OF BORING NO. B-1

Figure No. A-2

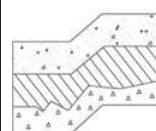
Project: PSE Operational Training Facility **Project No:** T-8829 **Date Drilled:** November 17, 2022

Client: Trammel Crow Company **Driller:** BoreTec **Logged By:** MJX

Location: Puyallup, Washington **Depth to Groundwater:** 4.5 ft **Approx. Elev:** NA

Depth (ft)	Sample Interval	Soil Description	Consistency/ Relative Density	SPT (N) Blows / foot			Moisture Content (%)	
				10	30	50		
0		Blackish-gray silty SAND, fine to coarse sand, moist to wet, trace rootlets, occasional silt seam. (SM)	Loose					
3				•			5	20.4
5				•			5	29.1
8				•			4	29.0
10		Blackish-gray SAND with silt, fine to coarse sand, wet, trace small organic fragments. (SP-SM)		•			7	27.5
10		Test Boring terminated at approximately 10 feet. Groundwater seepage observed at approximately 4.5 feet.						
15								

NOTE: This borehole log has been prepared for geotechnical purposes. This information pertains only to this boring location and should not be interpreted as being indicative of other areas of the site



Terra Associates, Inc.
 Consultants in Geotechnical Engineering
 Geology and
 Environmental Earth Sciences

LOG OF BORING NO. B-2

Figure No. A-3

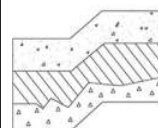
Project: PSE Operational Training Facility **Project No:** T-8829 **Date Drilled:** November 17, 2022

Client: Trammel Crow Company **Driller:** BoreTec **Logged By:** MJX

Location: Puyallup, Washington **Depth to Groundwater:** 4.5 ft **Approx. Elev:** NA

Depth (ft)	Sample Interval	Soil Description	Consistency/ Relative Density	SPT (N) Blows / foot			Moisture Content (%)
				10	30	50	
0		Blackish-gray SAND, fine to medium sand, moist, trace rootlets, occasional sandy silt seam. (SP)	Loose				
4.5							9
5		Gray sandy SILT, fine sand, wet, occasional clayey silt layer, occasional rootlet. (ML)	Soft				
7.5							6
8.5		Gray clayey SILT, wet, trace rootlets, interbedded sand seams. (ML)	Stiff				
10							2
10		Blackish-gray SAND, fine to coarse sand, wet, interbedded silt seams. (SP)	Loose				
11							9
11		Test Boring terminated at approximately 10 feet. Groundwater seepage observed at approximately 4.5 feet.					27.5
15							

NOTE: This borehole log has been prepared for geotechnical purposes. This information pertains only to this boring location and should not be interpreted as being indicative of other areas of the site



Terra Associates, Inc.
 Consultants in Geotechnical Engineering
 Geology and
 Environmental Earth Sciences

LOG OF BORING NO. B-3

Figure No. A-4

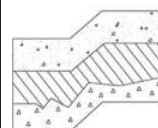
Project: PSE Operational Training Facility **Project No:** T-8829 **Date Drilled:** November 17, 2022

Client: Trammel Crow Company **Driller:** BoreTec **Logged By:** MJX

Location: Puyallup, Washington **Depth to Groundwater:** 4.5 ft **Approx. Elev:** NA

Depth (ft)	Sample Interval	Soil Description	Consistency/ Relative Density	SPT (N) Blows / foot			Moisture Content (%)	
				10	30	50		
0		Gray SILT, moist, mottled, occasional rootlet, occasional sand seam. (ML)	Medium Stiff				5	35.4
5		Gray clayey SILT, wet, occasional rootlet. (ML)	Soft				2	36.7
		Blackish-gray SAND with silt, fine to coarse sand, wet, occasional small organic fragment, occasional clayey silt seam. (SP-SM)	Loose				5	27.3
10							6	29.0
		Test Boring terminated at approximately 10 feet. Groundwater seepage observed at approximately 4.5 feet.						
15								

NOTE: This borehole log has been prepared for geotechnical purposes. This information pertains only to this boring location and should not be interpreted as being indicative of other areas of the site



Terra Associates, Inc.
 Consultants in Geotechnical Engineering
 Geology and Environmental Earth Sciences

LOG OF BORING NO. B-4

Figure No. A-5

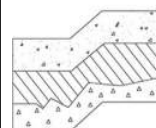
Project: PSE Operational Training Facility **Project No:** T-8829 **Date Drilled:** November 17, 2022

Client: Trammel Crow Company **Driller:** BoreTec **Logged By:** MJX

Location: Puyallup, Washington **Depth to Groundwater:** 4.5 ft **Approx. Elev:** NA

Depth (ft)	Sample Interval	Soil Description	Consistency/ Relative Density	SPT (N) Blows / foot			Moisture Content (%)
				10	30	50	
0		Gray SILT, moist, generally mottled, localized oxidized laminations, occasional rootlet, occasional charcoal inclusion. (ML)	Soft				
3						3	38.7
5		Blackish-gray to gray clayey SILT, wet, mottled, occasional rootlet, occasional sand with silt layer. (ML)	Medium Stiff				
8		*Interbedded sand seams observed*				8	31.9 23.7
10		Blackish-gray SAND, fine to coarse sand, wet, trace gravel, occasional silt seam. (SP)	Loose				
7						7	24.8
15		Test Boring terminated at approximately 10 feet. Groundwater seepage observed at approximately 4.5 feet.					

NOTE: This borehole log has been prepared for geotechnical purposes. This information pertains only to this boring location and should not be interpreted as being indicative of other areas of the site



Terra Associates, Inc.
 Consultants in Geotechnical Engineering
 Geology and
 Environmental Earth Sciences

LOG OF BORING NO. B-5

Figure No. A-6

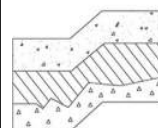
Project: PSE Operational Training Facility **Project No:** T-8829 **Date Drilled:** November 17, 2022

Client: Trammel Crow Company **Driller:** BoreTec **Logged By:** MJX

Location: Puyallup, Washington **Depth to Groundwater:** 4.5 ft **Approx. Elev:** NA

Depth (ft)	Sample Interval	Soil Description	Consistency/ Relative Density	SPT (N) Blows / foot			Moisture Content (%)	
				10	30	50		
0		Alternating layers of brownish-gray silty SAND and sandy SILT, fine to medium sand, moist, mottled, trace rootlets. (SM/ML)	Very Loose				3	27.7
5		Gray clayey SILT, wet, mottled, trace sand, occasional rootlet. (ML)	Soft				2	40.6
			Medium Stiff				6	36.8
		Blackish-gray SAND with silt, fine to medium sand, wet, occasional silt seam. (SP-SM)	Loose					25.2
10		Blackish-gray SAND, fine to coarse sand, wet, occasional silt layer. (SP)	Very Loose				3	26.1
		Test Boring terminated at approximately 10 feet. Groundwater seepage observed at approximately 4.5 feet.						
15								

NOTE: This borehole log has been prepared for geotechnical purposes. This information pertains only to this boring location and should not be interpreted as being indicative of other areas of the site



Terra Associates, Inc.
 Consultants in Geotechnical Engineering
 Geology and Environmental Earth Sciences

LOG OF BORING NO. B-6

Figure No. A-7

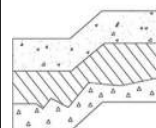
Project: PSE Operational Training Facility Project No: T-8829 Date Drilled: November 17, 2022

Client: Trammel Crow Company Driller: BoreTec Logged By: MJX

Location: Puyallup, Washington Depth to Groundwater: 6 ft Approx. Elev: NA

Depth (ft)	Sample Interval	Soil Description	Consistency/ Relative Density	SPT (N) Blows / foot			Moisture Content (%)	
				10	30	50		
0		Brownish-gray silty SAND, fine sand, moist, occasional rootlet, occasional clayey silt layer. (SM)	Loose				6	19.2
5		Alternating layers of silty SAND and sandy SILT, fine sand, moist to wet, mottled, occasional sand seam. (SM/ML)	Very Loose				3	28.8
		Gray SILT, moist to wet, mottled, interbedded sandy silt layers, occasional sand seam. (ML)	Soft				4	33.7
10		Gray clayey SILT, moist to wet, oxidized laminations. (ML)					3	39.7
		Test Boring terminated at approximately 10 feet. Groundwater seepage observed at approximately 6 feet.						
15								

NOTE: This borehole log has been prepared for geotechnical purposes. This information pertains only to this boring location and should not be interpreted as being indicative of other areas of the site



Terra Associates, Inc.
 Consultants in Geotechnical Engineering
 Geology and
 Environmental Earth Sciences

LOG OF BORING NO. B-7

Figure No. A-8

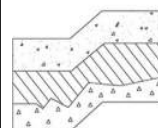
Project: PSE Operational Training Facility Project No: T-8829 Date Drilled: November 16, 2022

Client: Trammel Crow Company Driller: BoreTec Logged By: MJX

Location: Puyallup, Washington Depth to Groundwater: 6 ft Approx. Elev: NA

Depth (ft)	Sample Interval	Soil Description	Consistency/ Relative Density	SPT (N) Blows / foot			Moisture Content (%)	
				10	30	50		
0		Brownish-gray silty SAND, fine sand, moist to wet, slightly mottled, trace sandy silt seams, occasional rootlet. (SM)	Very Loose				3	18.9
5							5	38.0
		Brownish-gray SAND with silt, fine to medium sand, wet, trace silt layers. (SP-SM)	Loose				8	29.0
10		Gray clayey SILT, moist, trace small organic fragments, interbedded sand layers. (ML) *Numerous organic PEAT inclusions observed in upper 6 inches of sample*	Soft				3	42.2
		Blackish-gray SAND with silt, fine to medium sand, wet, occasional silt layer. (SP-SM)	Loose				9	29.3
15							17	29.1
		Gray SILT, moist, occasional small organic fragment, interbedded and inundated sand layers. (ML)	Very Stiff				19	27.9
20		Test Boring terminated at approximately 20 feet, Groundwater seepage observed at approximately 6 feet.						
25								

NOTE: This borehole log has been prepared for geotechnical purposes. This information pertains only to this boring location and should not be interpreted as being indicative of other areas of the site



Terra Associates, Inc.
 Consultants in Geotechnical Engineering
 Geology and Environmental Earth Sciences

LOG OF BORING NO. B-8

Figure No. A-9

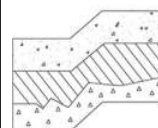
Project: PSE Operational Training Facility Project No: T-8829 Date Drilled: November 16, 2022

Client: Trammel Crow Company Driller: BoreTec Logged By: MJX

Location: Puyallup, Washington Depth to Groundwater: 10 ft Approx. Elev: NA

Depth (ft)	Sample Interval	Soil Description	Consistency/ Relative Density	SPT (N) Blows / foot			Moisture Content (%)	
				10	30	50		
0		FILL: Gray silty GRAVEL with sand, fine to coarse sand, fine to coarse gravel, wet, trace rootlets. (GM)	Loose	•			5	5.6
5		Brownish-gray clayey SILT, moist, mottled, trace sand seams, occasional rootlet. (ML)	Medium Stiff	•			5	30.4 16.8
		Brownish-gray SAND with silt, fine to medium sand, moist, occasional silt layer. (SP-SM)		•			5	36.0
10		Gray sandy SILT, fine to medium sand, moist, mottled, trace sand seams. (ML)	Loose	•			11	26.4
		Blackish-gray SAND with silt, fine to coarse sand, wet, occasional silt layer. (SP-SM)	Medium Dense	•			5	44.4
15		Gray SILT, moist to wet, trace sand seams, trace fine gravel. (ML)	Medium Stiff	•			13	28.6
		Blackish-gray SAND with silt, fine to medium sand, wet, occasional fine gravel. (SP-SM)		•			20	27.8
20		Dark gray SAND with silt, fine to medium sand, wet, occasional fine gravel, interbedded silt layers. (SP-SM)	Medium Dense	•			24	27.6
25		Blackish-gray SAND with silt, fine to medium sand, wet, interbedded silt layers. (SP-SM)		•			31	24.2
30			Dense	•				
35		Test Boring terminated at approximately 30 feet. Groundwater seepage observed at approximately 10 feet.						

NOTE: This borehole log has been prepared for geotechnical purposes. This information pertains only to this boring location and should not be interpreted as being indicative of other areas of the site



Terra Associates, Inc.
 Consultants in Geotechnical Engineering
 Geology and Environmental Earth Sciences

LOG OF BORING NO. B-9

Figure No. A-10

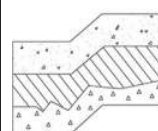
Project: PSE Operational Training Facility **Project No:** T-8829 **Date Drilled:** November 16, 2022

Client: Trammel Crow Company **Driller:** BoreTec **Logged By:** MJX

Location: Puyallup, Washington **Depth to Groundwater:** 7.5 ft **Approx. Elev:** NA

Depth (ft)	Sample Interval	Soil Description	Consistency/ Relative Density	SPT (N) Blows / foot			Moisture Content (%)	
				10	30	50		
0		Brownish-gray silty SAND, fine sand, moist, occasional gravel, occasional rootlet, interbedded sand seams, interbedded silt seams. (SM)	Loose	•			6	16.3
5				•			5	17.8
7.5		Gray sandy SILT, fine sand, moist to wet, mottled, interbedded and inundated sand seams. (ML)	Medium Stiff	•			7	33.5
10		Gray clayey SILT, moist to wet, occasional localized mottling, occasional localized oxidized lamination. (ML)		•			6	42.8
13		Gray SILT, wet, occasional small organic fragment. (ML)		•			4	40.4
15		Blackish-gray SAND with silt, fine to medium sand, wet, interbedded silt layers. (SP-SM)	Loose	•			9	30.7
20		Light brown organic PEAT, wet, fibrous, trace sand. (PT) (Partially decomposed tree trunk)		•			3	211.4
25		Gray sandy SILT, fine to medium sand, wet, interbedded silty sand layers. (ML)	Medium Dense		•		26	33.2
30		Gray SILT with sand, fine to medium sand, wet, interbedded silty sand layers. (ML)		•			13	32.2
30		Test Boring terminated at approximately 30 feet. Groundwater seepage observed at approximately 7.5 feet.						
35								

NOTE: This borehole log has been prepared for geotechnical purposes. This information pertains only to this boring location and should not be interpreted as being indicative of other areas of the site



Terra Associates, Inc.
 Consultants in Geotechnical Engineering
 Geology and
 Environmental Earth Sciences

LOG OF BORING NO. B-10

Figure No. A-11

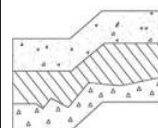
Project: PSE Operational Training Facility **Project No:** T-8829 **Date Drilled:** November 16, 2022

Client: Trammel Crow Company **Driller:** BoreTec **Logged By:** MJX

Location: Puyallup, Washington **Depth to Groundwater:** 10 ft **Approx. Elev:** NA

Depth (ft)	Sample Interval	Soil Description	Consistency/ Relative Density	SPT (N) Blows / foot			Moisture Content (%)	
				10	30	50		
0		Grayish-brown sandy SILT, fine sand, moist, localized mottling, localized oxidized laminations, trace small organic fragments, interbedded fine sand layers. (ML)	Loose				7	12.9
5							5	23.3
		Brownish-gray SAND, fine to medium sand, moist, occasional silt seam. (SP)					6	11.3
10		Gray SILT, moist to wet, oxidized laminations, trace small organic fragments, interbedded and inundated sand layers. (ML)	Medium Stiff				4	36.8
			Stiff				10	35.2
15		Gray SAND with silt, fine to medium sand, wet, interbedded silt layers. (SP-SM)	Medium Dense				14	28.4
20		Gray sandy SILT, fine sand, moist to wet, occasional silt seam, occasional wood waste inclusion. (ML)					13	32.6
		Test Boring terminated at approximately 20 feet. Groundwater seepage observed at approximately 10 feet.						
25								

NOTE: This borehole log has been prepared for geotechnical purposes. This information pertains only to this boring location and should not be interpreted as being indicative of other areas of the site



Terra Associates, Inc.
 Consultants in Geotechnical Engineering
 Geology and Environmental Earth Sciences

LOG OF BORING NO. B-11

Figure No. A-12

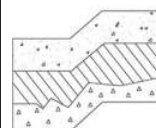
Project: PSE Operational Training Facility **Project No:** T-8829 **Date Drilled:** November 16, 2022

Client: Trammel Crow Company **Driller:** BoreTec **Logged By:** MJX

Location: Puyallup, Washington **Depth to Groundwater:** 10 ft **Approx. Elev:** NA

Depth (ft)	Sample Interval	Soil Description	Consistency/ Relative Density	SPT (N) Blows / foot			Moisture Content (%)	Observ. Well	
				10	30	50			
0		Brownish-gray SILT with sand, fine sand, moist, mottled, trace rootlets. (ML)	Medium Stiff				4	36.6	
5		Brownish-gray silty SAND, fine sand, moist to wet, interbedded silt with sand layers. (SM)	Loose				4	24.3	
		Gray SAND with silt, fine to medium sand, moist to wet, interbedded and mottled silty sand and silt layers. (SP-SM)						5	
10							4	30.7	
		Gray SILT, moist to wet, interbedded and inundated sand with silt layers. (ML)	Stiff				8	46.2	
15		Gray SAND with silt, fine to medium sand, wet, occasional silt layer. (SP-SM)	Medium Dense				11	31.2	
20		Test Boring terminated at approximately 15 feet. Groundwater seepage observed at approximately 10 feet. Boring converted to groundwater monitoring well with monument no. BNV 571.							

NOTE: This borehole log has been prepared for geotechnical purposes. This information pertains only to this boring location and should not be interpreted as being indicative of other areas of the site



Terra Associates, Inc.
 Consultants in Geotechnical Engineering
 Geology and Environmental Earth Sciences

LOG OF BORING NO. B-12

Figure No. A-13

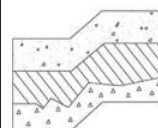
Project: PSE Operational Training Facility Project No: T-8829 Date Drilled: November 16, 2022

Client: Trammel Crow Company Driller: BoreTec Logged By: MJX

Location: Puyallup, Washington Depth to Groundwater: 9 ft Approx. Elev: NA

Depth (ft)	Sample Interval	Soil Description	Consistency/ Relative Density	SPT (N) Blows / foot			Moisture Content (%)	
				10	30	50		
0		FILL: Gray GRAVEL with silt and sand, fine to coarse sand, fine to coarse gravel, moist, scattered rootlets. (GP-GM)	Loose				8	9.1
5		Gray SILT, moist, mottled, trace sand seams. (ML)	Stiff				11	32.5
		Brown SAND, fine to coarse sand, moist, (SP)						9.6
		Gray SAND with silt, fine to coarse sand, moist to wet, trace gravel, occasional silt seam. (SP-SM)					10	16.3
10		Blackish-gray SAND, fine to coarse sand, wet, trace fine gravel, trace silt. (SP)	Medium Dense				11	24.7
							12	18.7
15			Loose				9	19.8
		Test Boring terminated at approximately 15 feet. Groundwater seepage observed at approximately 9 feet.						
20								

NOTE: This borehole log has been prepared for geotechnical purposes. This information pertains only to this boring location and should not be interpreted as being indicative of other areas of the site



Terra Associates, Inc.
 Consultants in Geotechnical Engineering
 Geology and Environmental Earth Sciences

LOG OF BORING NO. B-13

Figure No. A-14

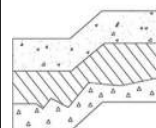
Project: PSE Operational Training Facility **Project No:** T-8829 **Date Drilled:** November 16, 2022

Client: Trammel Crow Company **Driller:** BoreTec **Logged By:** MJX

Location: Puyallup, Washington **Depth to Groundwater:** 10 ft **Approx. Elev:** NA

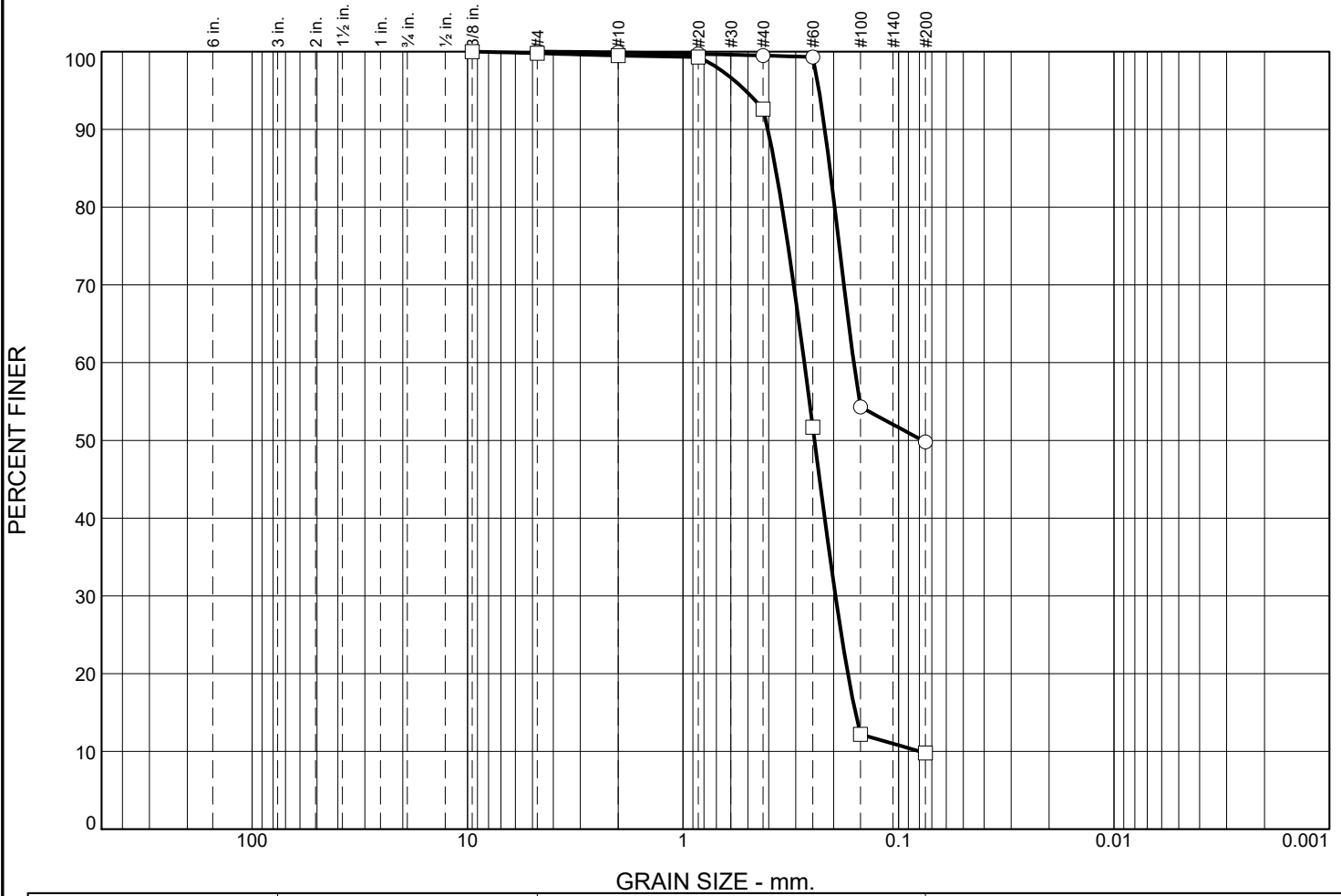
Depth (ft)	Sample Interval	Soil Description	Consistency/ Relative Density	SPT (N) Blows / foot			Moisture Content (%)	Observ. Well
				10	30	50		
0		FILL: Gray GRAVEL with silt and sand, fine to coarse sand, fine to coarse gravel, moist. (GP-GM)	Medium Dense			14	9.9	
5		Brownish-gray sandy SILT, fine sand, moist, mottled, occasional gravel, occasional rootlet. (ML)	Loose			4	22.3	
10		Gray SILT, moist to wet, oxidized laminations, trace sand, occasional small organic fragment, interbedded sand with silt and silty sand layers. (ML)	Medium Stiff			8	20.1	
15		Blackish-gray SAND with silt, fine to medium sand, wet, occasional fine gravel, interbedded silty sand and silt layers. (SP-SM)				5	36.5	
20						8	26.5	
25			Medium Dense			10	31.2	
30						29	25.0	
35		Test Boring terminated at approximately 30 feet. Groundwater seepage observed at approximately 10 feet. Boring converted to groundwater monitoring well with monument no. BNV 572.				16	26.6	
						24	24.9	

NOTE: This borehole log has been prepared for geotechnical purposes. This information pertains only to this boring location and should not be interpreted as being indicative of other areas of the site



Terra Associates, Inc.
 Consultants in Geotechnical Engineering
 Geology and Environmental Earth Sciences

Particle Size Distribution Report



	% +3"	% Gravel		% Sand			% Fines	
		Coarse	Fine	Coarse	Medium	Fine	Silt	Clay
○	0.0	0.0	0.0	0.1	0.4	49.7	49.8	
□	0.0	0.0	0.2	0.3	6.9	82.8	9.8	

	LL	PL	D ₈₅	D ₆₀	D ₅₀	D ₃₀	D ₁₅	D ₁₀	C _c	C _u
○			0.2081	0.1612	0.0773					
□			0.3720	0.2736	0.2455	0.1961	0.1585	0.0795	1.77	3.44

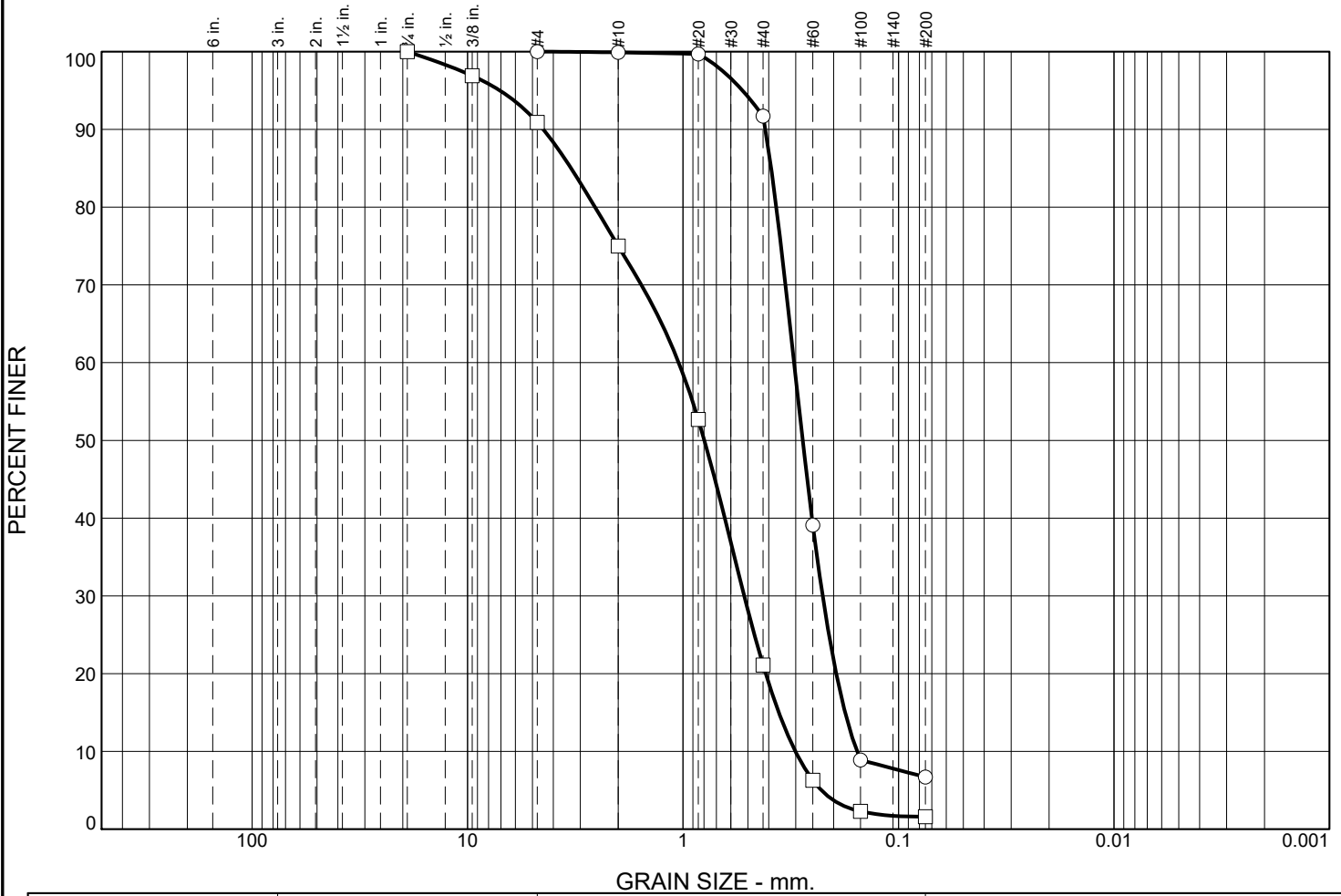
Material Description							USCS	AASHTO
○ Silty SAND							SM	
□ SAND with silt							SP-SM	

<p>Project No. T-8829 Client: Trammel Crow Company</p> <p>Project: PSE Operational Training Facility</p> <p>○ Location: Test Boring B-7 Depth: 2.5 ft Sample Number: 1</p> <p>□ Location: Test Boring B-8 Depth: 15 ft Sample Number: 7</p> <p style="text-align: center;">Terra Associates, Inc.</p> <p style="text-align: center;">Kirkland, WA</p>	<p>Remarks:</p> <p>○ Tested on November 29, 2022</p> <p>□ Tested on November 29, 2022</p>
-------------------------------------------------------------------------------------------------------------------------------------------------------------------------------------------------------------------------------------------------------------------------------------------------------------------------------------------------------------------------------------------------------------------------------------------------------------	--------------------------------------------------------------------------------------------------

Figure A-15

Tested By: KJ

Particle Size Distribution Report



	% +3"	% Gravel		% Sand			% Fines	
		Coarse	Fine	Coarse	Medium	Fine	Silt	Clay
○	0.0	0.0	0.0	0.1	8.2	85.0	6.7	
□	0.0	0.0	9.1	15.9	53.9	19.5	1.6	

	LL	PL	D85	D60	D50	D30	D15	D10	Cc	Cu
○			0.3897	0.3051	0.2784	0.2251	0.1769	0.1556	1.07	1.96
□			3.3088	1.0474	0.7961	0.5200	0.3592	0.3008	0.86	3.48

Material Description							USCS	AASHTO
○ SAND with silt							SP-SM	
□ SAND							SP	

<p>Project No. T-8829 Client: Trammel Crow Company</p> <p>Project: PSE Operational Training Facility</p> <p>○ Location: Test Boring B-8 Depth: 25 ft Sample Number: 9</p> <p>□ Location: Test Boring B-12 Depth: 15 ft Sample Number: 7</p> <p style="text-align: center;">Terra Associates, Inc.</p> <p style="text-align: center;">Kirkland, WA</p>	<p>Remarks:</p> <p>○ Tested on November 29, 2022</p> <p>□ Tested on November 29, 2022</p>
-------------------------------------------------------------------------------------------------------------------------------------------------------------------------------------------------------------------------------------------------------------------------------------------------------------------------------------------------------------------------------------------------------------------------------------------------------------	--------------------------------------------------------------------------------------------------

Figure A-16

Tested By: KJ

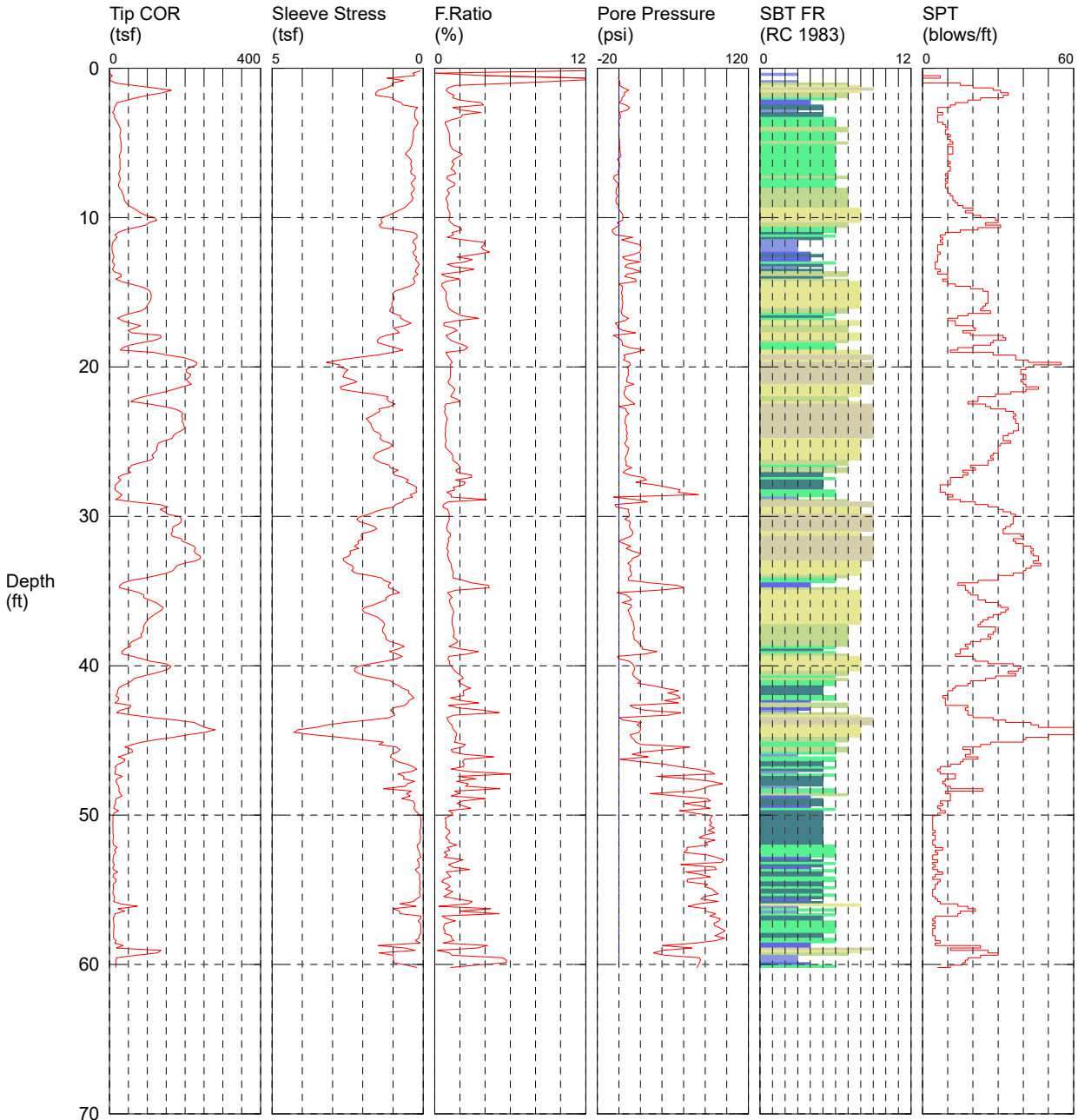
CPT LOGS



CPT-01

CPT CONTRACTOR: In Situ Engineering
 CUSTOMER: Terra Associates
 LOCATION: Puyallup
 JOB NUMBER: T-8829
 COMMENT: PSE Operational Training Center

OPERATOR: Okbay
 CONE ID: DDG1351
 TEST DATE: 11/18/2022 11:40:03 AM
 PREDRILL: 0 ft
 BACK FILL: 20% Grout + Bentonite Chips
 SURFACE PATCH: None



TOTAL DEPTH: 60.203 ft

DEPTH INTERVAL: 0.050 m

- | | | | |
|--------------------------|-----------------------------|----------------------------|--------------------------------|
| 1 sensitive fine grained | 4 silty clay to clay | 7 silty sand to sandy silt | 10 gravelly sand to sand |
| 2 organic material | 5 clayey silt to silty clay | 8 sand to silty sand | 11 very stiff fine grained (*) |
| 3 clay | 6 sandy silt to clayey silt | 9 sand | 12 sand to clayey sand (*) |

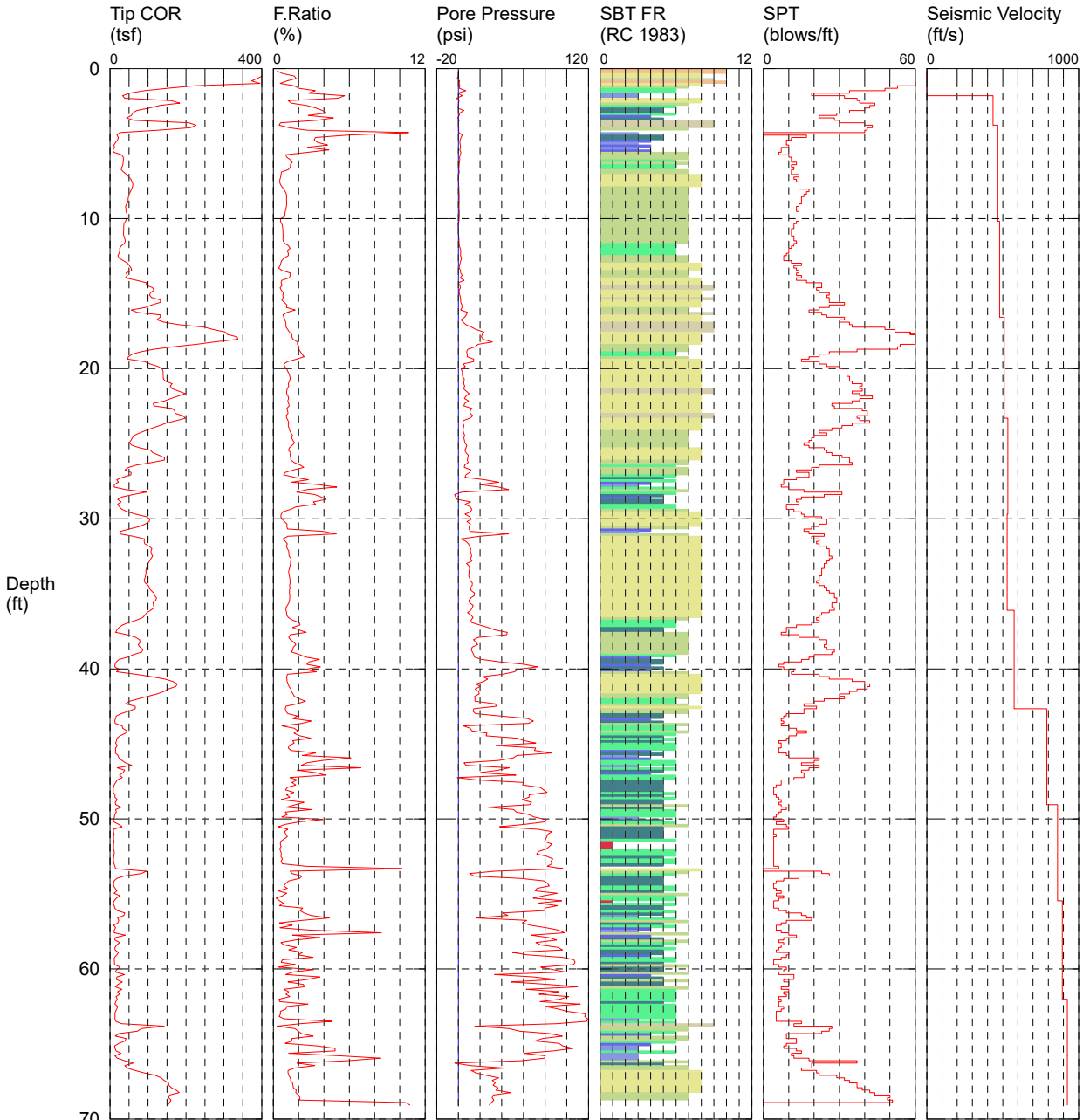
*SBT/SPT CORRELATION: UBC-1983



CPT-02

CPT CONTRACTOR: In Situ Engineering
 CUSTOMER: Terra Associates
 LOCATION: Puyallup
 JOB NUMBER: T-8829
 COMMENT: PSE Operational Training Center

OPERATOR: Okbay
 CONE ID: DDG1351
 TEST DATE: 11/18/2022 1:29:19 PM
 PREDRILL: 0 ft
 BACK FILL: 20% Grout + Bentonite Chips
 SURFACE PATCH: None



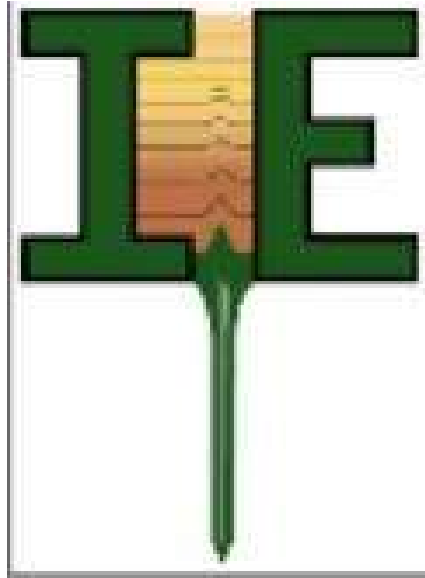
TOTAL DEPTH: 69.062 ft

DEPTH INTERVAL: 0.050 m

- | | | | |
|--------------------------|-----------------------------|----------------------------|--------------------------------|
| 1 sensitive fine grained | 4 silty clay to clay | 7 silty sand to sandy silt | 10 gravelly sand to sand |
| 2 organic material | 5 clayey silt to silty clay | 8 sand to silty sand | 11 very stiff fine grained (*) |
| 3 clay | 6 sandy silt to clayey silt | 9 sand | 12 sand to clayey sand (*) |

*SBT/SPT CORRELATION: UBC-1983

HOLE NUMBER: CPT-02



OPERATOR: Okbay

CPT CONTRACTOR: In Situ Engineering

CUSTOMER:

CONE ID: DDG1351

LOCATION: Puyallup

TEST DATE: 11/18/2022 1:29:19 PM

JOB NUMBER: T-8829

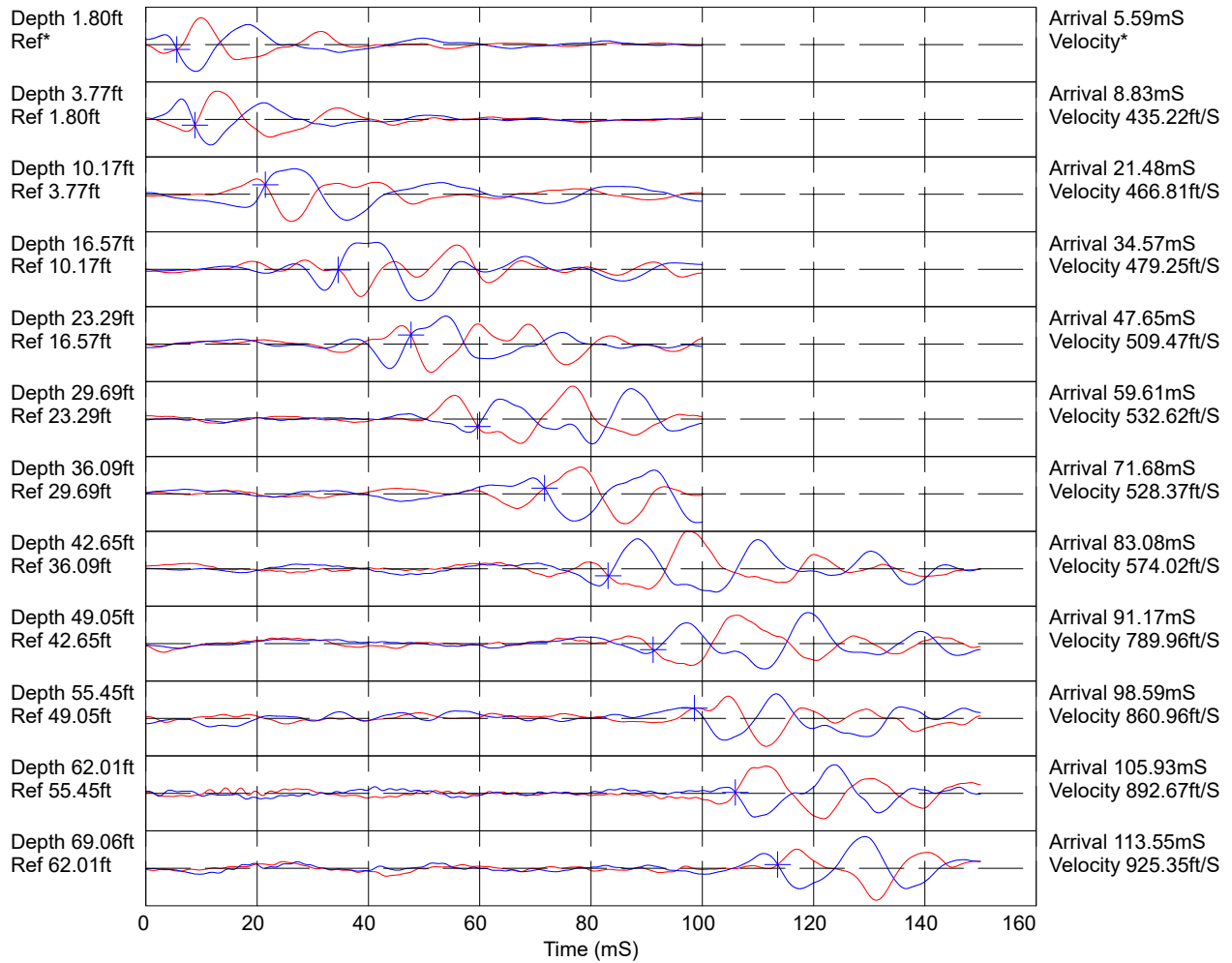
COMMENT: PSE Operational Training Center

PREDRILL 0 ft

BACK FILL: 20% Grout + Bentonite Chips

SURFACE PATCH: None

HOLE NUMBER: CPT-02



Hammer to Rod String Distance (ft): 2.62
 * = Not Determined

COMMENT: PSE Operational Training Center

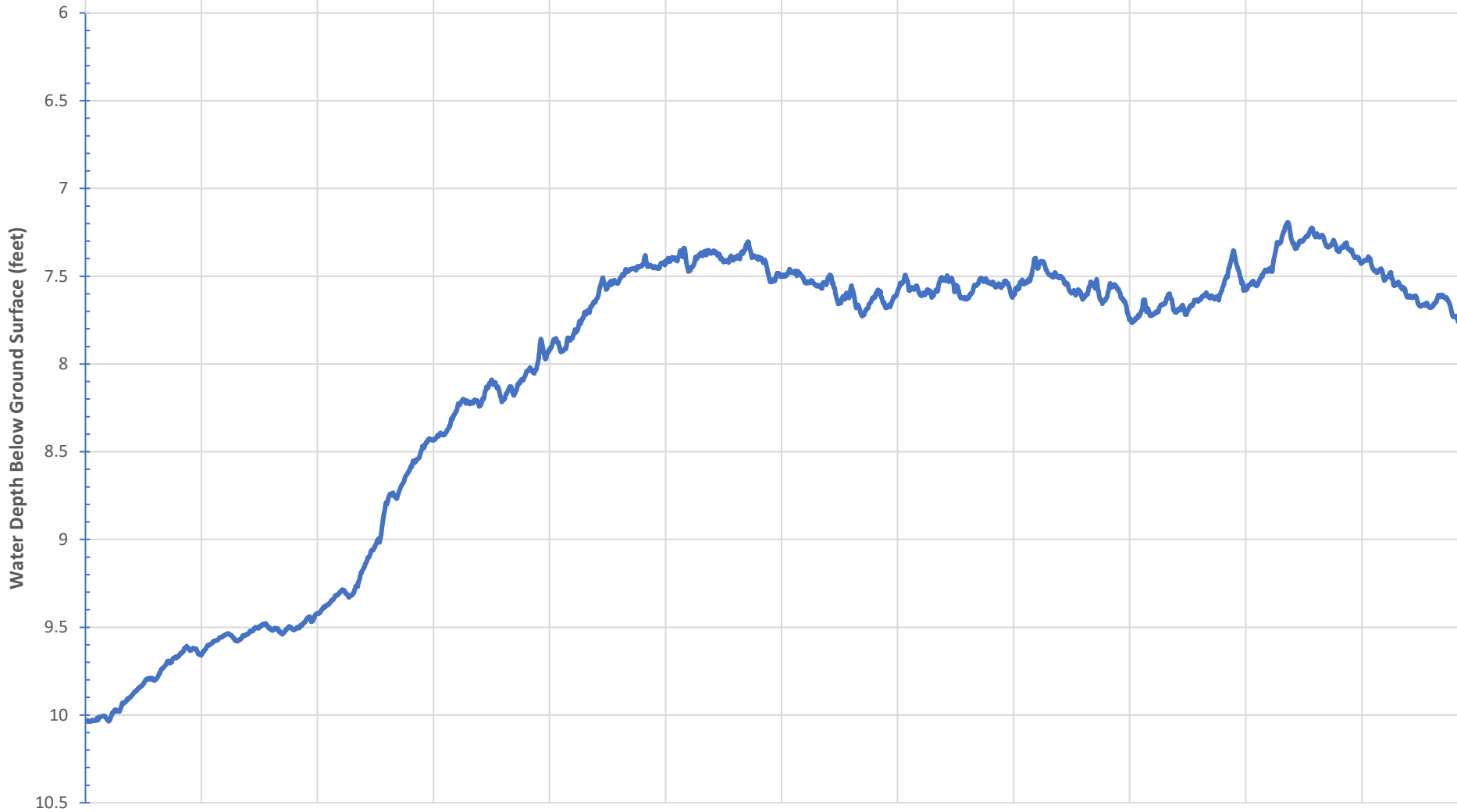
APPENDIX B

GROUNDWATER MONITORING HYDROGRAPHS

T-8829 PSE Operational Training Facility Test Boring B-11 Depth to Groundwater

Date & Time

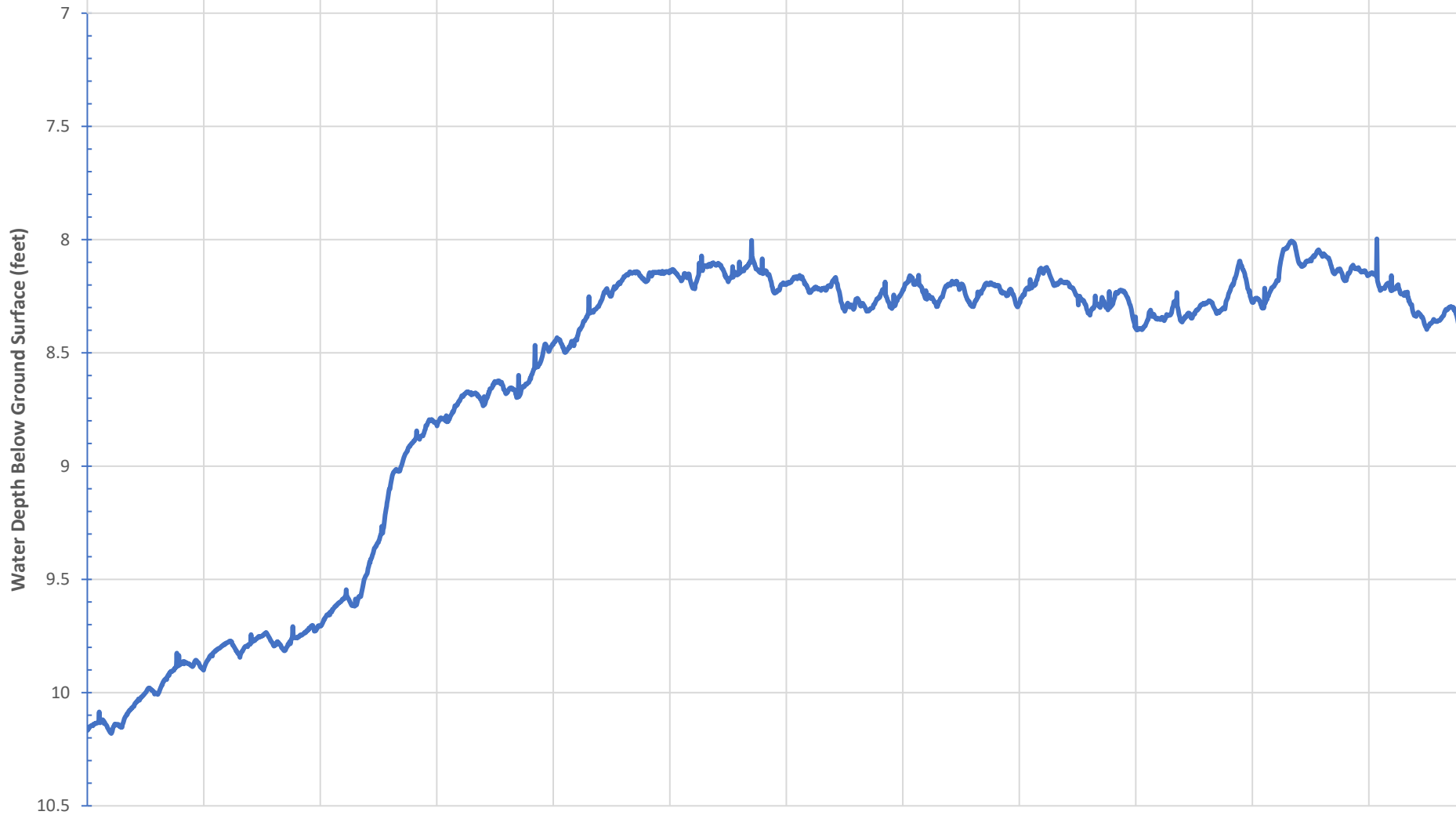
12/1/2022 12:00:00 AM 12/11/2022 12:00:00 AM 12/21/2022 12:00:00 AM 12/31/2022 12:00:00 AM 1/10/2023 12:00:00 AM 1/20/2023 12:00:00 AM 1/30/2023 12:00:00 AM 2/9/2023 12:00:00 AM 2/19/2023 12:00:00 AM 3/1/2023 12:00:00 AM 3/11/2023 12:00:00 AM 3/21/2023 12:00:00 AM



T-8829 PSE Operational Training Facility Test Boring B-13 Depth to Groundwater

Date & Time

12/1/2022 12:00:00 AM 12/11/2022 12:00:00 AM 12/21/2022 12:00:00 AM 12/31/2022 12:00:00 AM 1/10/2023 12:00:00 AM 1/20/2023 12:00:00 AM 1/30/2023 12:00:00 AM 2/9/2023 12:00:00 AM 2/19/2023 12:00:00 AM 3/1/2023 12:00:00 AM 3/11/2023 12:00:00 AM 3/21/2023 12:00:00 AM



APPENDIX C

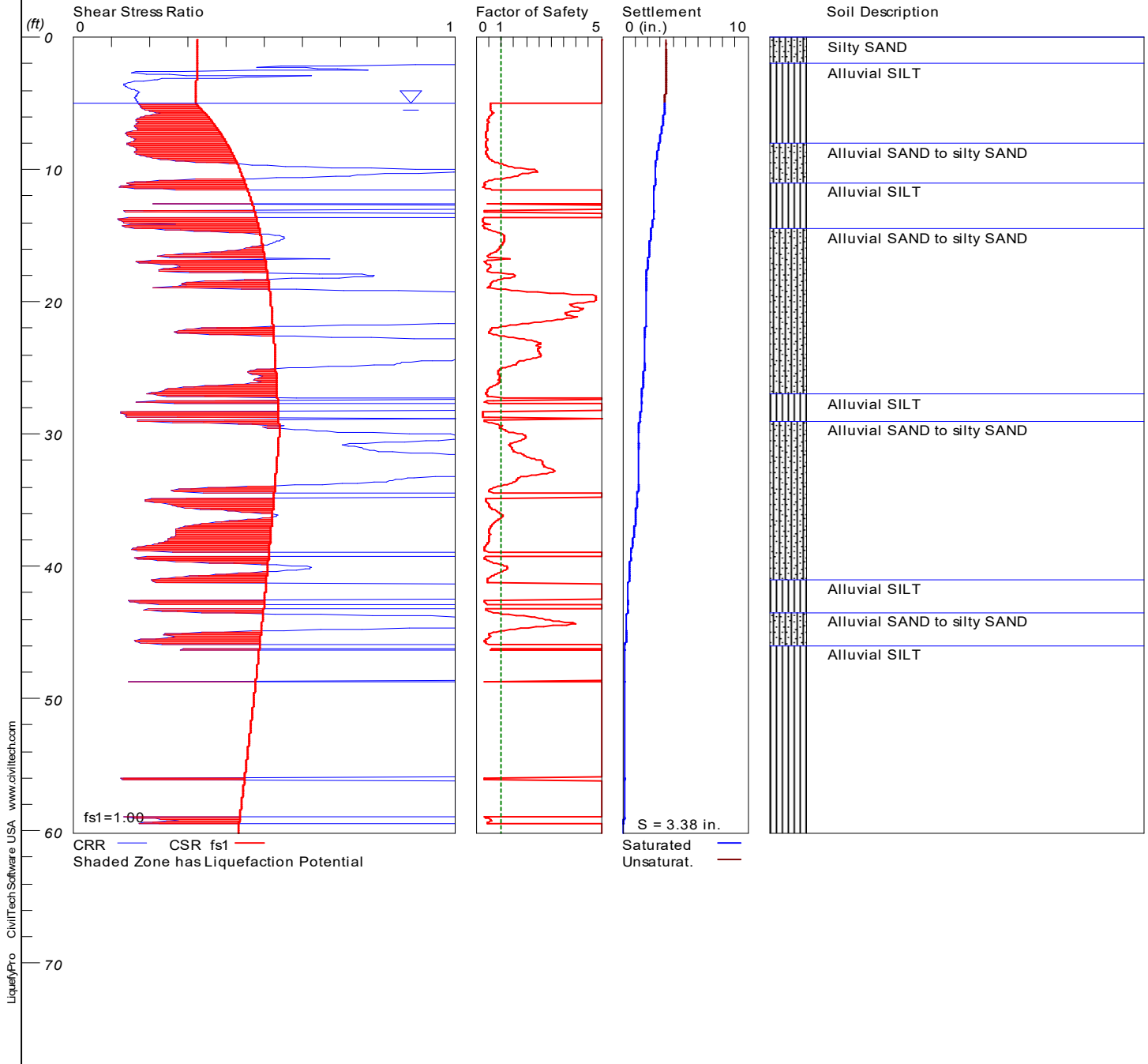
LIQUEFACTION ANALYSIS RESULTS

LIQUEFACTION ANALYSIS

T-8829 PSE Operational Training Facility

Hole No.=CPT-01 Water Depth=5 ft

Magnitude=7
Acceleration=0.5g

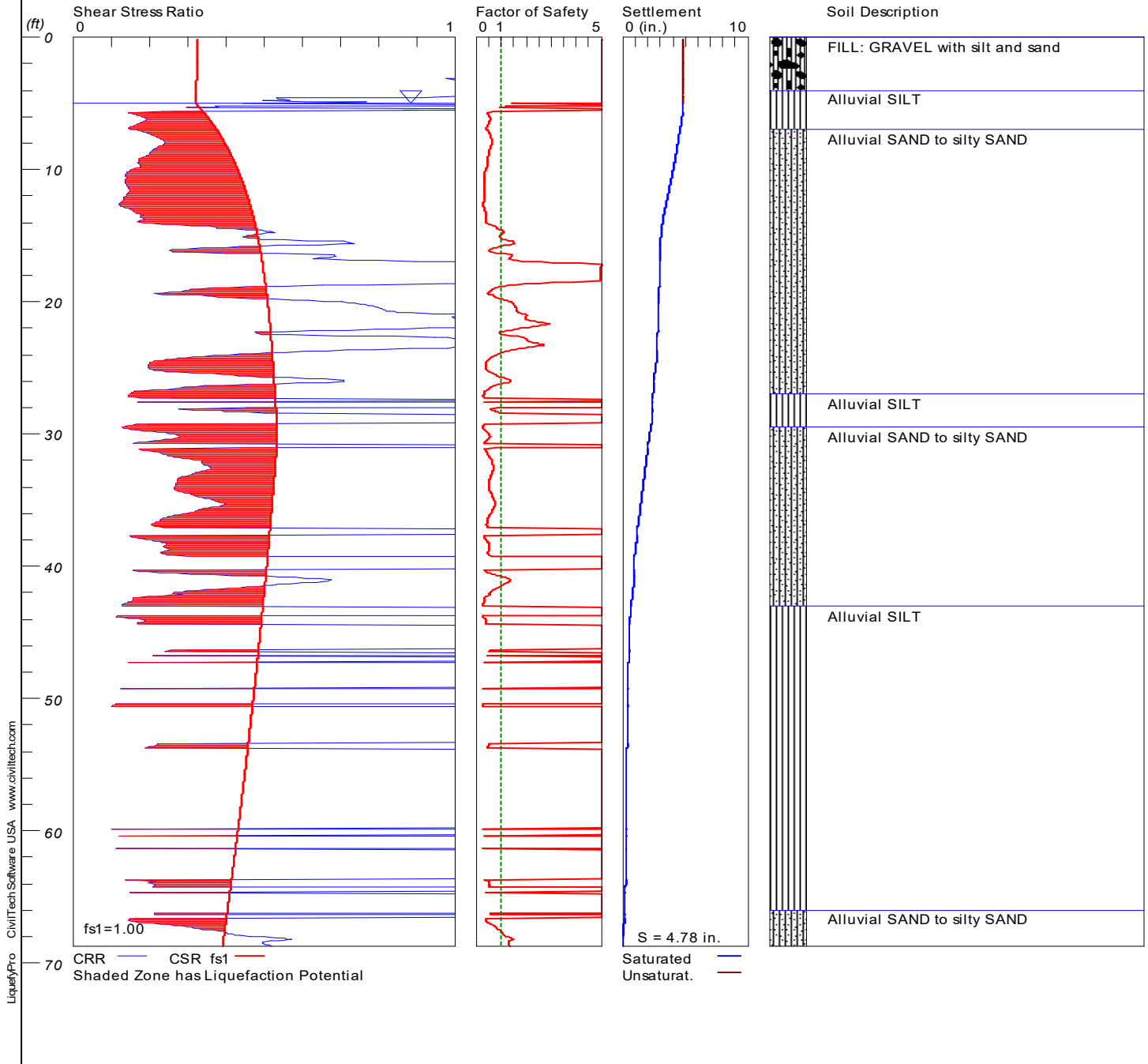


LIQUEFACTION ANALYSIS

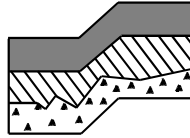
T-8829 PSE Operational Training Facility

Hole No.=CPT-02 Water Depth=5 ft

**Magnitude=7
Acceleration=0.5g**



DESIGN MEMORANDUM



TERRA ASSOCIATES, Inc.

Consultants in Geotechnical Engineering, Geology
and
Environmental Earth Sciences

To:	<u>Alex Garcia Mendoza</u>	Date:	<u>6-8-23</u>
	<u>Trammell Crow Company</u>	Project No.:	<u>T-8829</u>
From:	<u>Ted Schepper, P.E.</u>	Project Name:	<u>PSE Operation Training Center</u>
Subject:	<u>Heavy Duty Traffic Areas</u>		<u>Puyallup, Washington</u>
Ref:	<u>Terra Associates Geotechnical Report, PSE Operational Training Center, dated April 6, 2023</u>		

Alex,

As requested we have evaluated pavement design sections for the subject project relative to vehicle loading that will traverse the sections. Based on information provided by PSE the heaviest vehicles that will traffic the site include a 50-ton mobile crane and a low boy tractor/trailer that are used primarily to move and transport transformer equipment. Both vehicles have a gross loaded weight of 200,000 pounds.

Based on our analysis the current recommended heavy traffic hot mix asphalt (HMA) pavement section outlined in our referenced report would be capable of supporting these heavier vehicles. The section is as follows:

- Three inches of HMA over eight inches of crushed surfacing rock

For the western training area of the site where the yard and access routes will be gravel surfaced the following section is recommended:

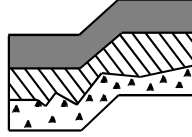
- Four inches of crushed surfacing top course rock over 6 inches of crushed surfacing base course rock over ten inches of gravel base over Mirafi 600X or equal stabilization fabric.

The paving materials used should conform to the Washington State Department of Transportation (WSDOT) specifications for half-inch class HMA, crushed surfacing, and gravel base. Pavement subgrade should be prepared as recommended in our referenced geotechnical report.

If you have any questions or require additional information, please call.


Theodore J. Schepper
6-8-23

DESIGN MEMORANDUM



TERRA ASSOCIATES, Inc.

Consultants in Geotechnical Engineering, Geology
and
Environmental Earth Sciences

To: Thomas Mun Date: 7-10-23
Trammell Crow Company Project No.: T-8829
From: Ted Schepper, P.E. Project Name: PSE Operation Training Center
Subject: Heavy Duty Traffic Areas Puyallup, Washington
Ref: Terra Associates Design Memo, Heavy Duty Traffic Areas, PSE OTC, dated June 8, 2023

Tomas,

Since issuance of the referenced design memo, we have been requested to review additional use and traffic scenarios and provide alternate rock surface pavement sections that can be used in the western training yard area of the project. As discussed in the referenced memo, where traffic will include the 50-ton mobile crane and a low boy tractor/trailer the recommended rock section consists of the following:

- Four inches of crushed surfacing top course rock over 6 inches of crushed surfacing base course rock over ten inches of gravel base over Mirafi 600X or equal stabilization fabric.

If stabilization fabric is not used, the thickness of the gravel base should be increased to 14-inches.

Where traffic will not include the mobile crane or low boy, we understand the maximum vehicle size that will traverse the rock section will weigh 54,000 pounds. In these areas the following rock section is recommended:

- Four inches of crushed surfacing top course rock over four inches of crushed surfacing base course rock over ten inches of gravel base.

As we understand there will also be inside islands where the only traffic will consist of lightweight cars and trucks where training will include potholing. In these areas the following rock section is recommended:

- Two inches of crushed surfacing top course rock over four inches of crushed surfacing base course rock over 6 inches of gravel base.

The crushed surfacing rock and gravel base used should conform to the Washington State Department of Transportation (WSDOT) specifications. Subgrade preparation for support of the rock sections should be prepared as recommended in our referenced geotechnical report.

If you have any questions or require additional information, please call.

Theodore J. Schepper
7-10-23

A circular blue seal for Theodore J. Schepper, a Registered Professional Engineer in the State of Washington. The seal contains the text "THEODORE J. SCHEPPER", "STATE OF WASHINGTON", "REGISTERED PROFESSIONAL ENGINEER", and the number "25742".



TERRA ASSOCIATES, Inc.

Consultants in Geotechnical Engineering, Geology
and
Environmental Earth Sciences

June 12, 2023
Revised August 1, 2023
Project No. T-8829

Mr. Alex Garcia Mendoza
Trammell Crow Company
600 University Street, Suite 2912
Seattle, Washington 98101

Subject: Critical Aquifer Recharge Areas Evaluation
PSE Operational Training Center
221 and 325 Todd Road Northwest
Puyallup, Washington

Reference: Geotechnical Report, PSE Operational Training Center, Project No. T-8829,
prepared by Terra Associates, Inc., dated April 6, 2023

Dear Mr. Garcia Mendoza:

As requested, we performed an aquifer recharge and wellhead protection area review of the subject site. The purpose of our study was to determine if the site is located within the boundaries of aquifer recharge areas or wellhead protection areas as defined in Chapter 21.06.1110 (Designation, mapping and rating) of the Puyallup Municipal Code (PMC) and to conduct a hydrogeologic assessment of the site in accordance with the requirements of PMC 21.06.1150 (Critical area report requirements for critical aquifer recharge areas).

The site is located within the boundaries of an aquifer recharge area and wellhead protection areas per the defining criteria given in PMC 21.06.1110.3(a) and 21.06.1110.3(b), respectively. The site location is rated as a high susceptibility aquifer recharge area per the criteria given in PMC 21.06.1110.4(a). Review of the Washington State Department of Health (WSDOH) Source Water Assessment Program (SWAP) interactive GIS mapping tool (<https://fortress.wa.gov/doh/swap/index.html>) shows the all but the southwestern portion of the site overlain by the 6-month, 1-year, 5-year, and 10-year time-of-travel (TOT) zones of two wells operated by a Group A water system identified as Mountainview-Edgewood Water Company (MEWC). Smaller portions of the site are within the 5-year and 10-year TOT zones of a City of Puyallup (COP) well, and the 10-year TOT zone of a Group A water system well operated by DeChaux Mutual Water (DMW). The position of the site relative to the time-of-travel plots of these systems is shown on Figure 1. The SWAP map shows the site within the boundary of the Puyallup-White Watershed.

SITE DESCRIPTION

The site is a vacant, triangular-shaped, 6.17-acre parcel located northeast of and adjacent to the intersection of Todd Road NW and 4th Street NW in Puyallup, Washington. A northwest-trending Union Pacific Railroad right-of-way (ROW) borders the northern site margin. The site location is near the northern margin of the Puyallup River alluvial plain, approximately 3,200 feet north of the river channel. The approximate site location is shown on Figure 2.

Site topography is relatively flat with a topographic relief of about 8 feet between the western and southeastern site margins. Topographic information obtained from the Pierce County Public GIS (PCPGIS) interactive mapping tool website (<https://matterhornwab.co.pierce.wa.us/publicgis/>) shows site elevations ranging between Elev. 40 at the western site margin and about Elev. 48 near the southeastern site corner. Maximum surface gradients at the site are about 3 percent.

Historical aerial photographs of the site obtained from the PCPGIS website show residential farm buildings occupying the southwestern and central portions of the site until about 2018. An equipment and materials storage yard occupies the central portion of the site in aerial photographs from 2020 and 2021. Site vegetation consists primarily of grasses with scattered mature coniferous and deciduous trees. A significant portion of the former storage yard area is surfaced with gravel.

OTHER CRITICAL AREAS REVIEW

The PCPGIS website shows several environmentally-significant surface features located within 1,300 feet of the site. The type of surface feature and general direction and distance from the site are given below: The approximate location of each surface feature relative to the site is shown on Figure 3.

Type of Feature	Feature ID	Distance (feet) ¹	Direction	Hydrogeologic Position Relative to Site
Wetland ²	WL1	43	West	Downgradient
	WL2	830	West-Northwest	Downgradient
Regulated Floodplain	RFP1	820	Northeast	Upgradient
	RFP2	510	North-Northwest	Crossgradient
	RFP3	350	Northwest	Downgradient
	RFP4	325	West	Downgradient
	RFP5	75	West	Downgradient
	RFP6	540	West	Downgradient
	RFP7	950	Northwest	Downgradient
	RFP8	1,275	West	Downgradient
	RFP9	880	South	Crossgradient
	RFP0	1,010	South	Crossgradient
	RFP11	820	South-Southeast	Crossgradient
	RFP12	1,120	Southeast	Upgradient
Floodway	FW1	620	West	Downgradient
	FW2	820	South-Southeast	Crossgradient
	FW3	1,120	Southeast	Upgradient
Stream	STRM1	360	Northwest	Downgradient
	STRM2	1,150	Southeast	Upgradient

1 – Distance from site perimeter to closest edge of feature.

2 – Delineated wetland area per Puyallup GIS

Mr. Alex Garcia Mendoza
June 12, 2023
Revised August 1, 2023

We evaluated site conditions for the presence of geologically hazardous areas as part of our geotechnical engineering study of the site. The results of our evaluation are discussed in Section 3.4 of the referenced geotechnical report.

PROJECT DESCRIPTION

A schematic site plan by Zervas, dated July 21, 2023, shows the project consisting of a centrally-located, 33,837 square-foot building with outdoor training features located west of the building. The outdoor training features include several smaller buildings, covered areas, a burn pit, substation yard and other training features.

Stormwater runoff will be conveyed to a detention pond located in the eastern portion of the site. Pond elevations are currently not available. The proposed development plan is shown on Figure 4.

SUBSURFACE CONDITIONS

Soils

We explored subsurface conditions at the site by drilling 13 test borings to depths of 10 to 30 feet with a track-mounted drill rig using hollow-stem auger drilling methods, and by advancing two cone penetration tests (CPTs) to maximum depths of 60 and 70 feet. The boring logs and CPT plots are presented in Appendix A. The approximate boring and CPT locations are shown on Figure 4.

The soils observed in the test borings are alluvial deposits comprised predominantly of interbedded silt to clayey silt, silty fine sand, and sand. The CPT data indicates that the alluvial deposits below a depth of 45 feet consist primarily of silt to clayey silt; however, medium dense to very dense sand deposits are indicated below a depth of about 67 feet in CPT-2. We observed up to approximately four feet of fill consisting of loose to medium dense gravel with silt and sand to silty gravel with sand in Test Borings B-8, B-12, and B-13.

The *Geologic Map of the Tacoma 1:100,000-Scale Quadrangle, Washington*, by J.E. Schuster, A.A Cabibbo, J.F. Schilter, and I.J. Hubert (2015) shows surficial geology at the site mapped as Holocene alluvium (Qa). The soils observed in the subsurface explorations are consistent with this geologic map unit. The referenced geologic map is attached as Figure 5.

Groundwater

Wet soils indicative of groundwater saturation were encountered below depths ranging from about 4.5 feet in Borings B-1 through B-5 to about 10 feet in Borings B-8, B-10, B-11, and B-13 during drilling. Groundwater levels at the site will fluctuate on a seasonal basis with highest levels occurring during the normally wet winter and spring months. This seasonal increase of groundwater levels was observed by monitoring of wells installed in Borings B-11 and B-13, which showed water levels generally fluctuating between depths of about 7.2 and 7.8 feet in B-11 and between depths of about 8 and 8.4 feet in B-13 between mid-January 2023 and mid-April 2023.

Based on area topography, our observations of surface drainage patterns in the site vicinity, and the northwesterly direction of flow in the Puyallup River approximately 3,200 feet south of the site, we expect that the direction of shallow groundwater flow beneath the site is generally to the west-northwest.

Hydrogeology

Based on our study, two primary groundwater regimes are present in the site vicinity. These include the relatively shallow Puyallup Valley water table aquifer and the deeper Vashon advance outwash aquifer (Qva aquifer). The Qva aquifer includes the Redondo-Milton Channel (RMC) aquifer, which according to the MEWC 2022 Water Quality Report, is the aquifer that MEWC Wells 1R and 8 draw from.

WATER WELL REVIEW

We reviewed available well log records obtained from the Washington State Department of Ecology (DOE) Well Report Viewer website (<https://fortress.wa.gov/ecy/wellconstruction/map/WCLSWebMap/default.aspx>) for existing water wells located in the site vicinity. Our research of the DOE database found driller's logs or related documents associated with 25 wells potentially located within a 1,300 foot radius from the site. Further review determined that four of the wells are located outside of the search radius and sixteen of the wells had been decommissioned or were used for irrigation or dewatering purposes. Five water wells used for domestic or municipal purposes are potentially located within the 1,300-foot search radius.

The approximate locations of the five wells relative to the subject site are shown on Figure 6. Documented well details and driller's logs are attached as Appendix B. Brief summaries of the five wells identified in the DOE database search are given below:

1. Burton Wulf Well (SE ¼ of SE ¼ of Section 16, Township 20N, Range 4E):

The DOE database incorrectly lists the well owner as Burton Wulf. Located approximately 970 feet north and crossgradient from the subject site. The street address of the well is not given. The well is finished in sand and gravel deposits, interpreted to be the RMC aquifer, that underlies about 238 feet of soil described as clay and silt. The static water level in the well is reported to be at a depth of 4 feet.

3. Frank DeChaux Well (DOE Well ID AEF399) (SE ¼ of SE ¼ of Section 16, Township 20N, Range 4E):

This is a Group A well operated by DeChaux Mutual Water. The well is located approximately 1,055 feet north and crossgradient from the subject site. The street address of the well is not given. The well was drilled to a depth of 103 feet and screened in coarse sand and gravel deposits, interpreted to be the RMC aquifer, between depths of 83 and 93 feet. The sand and gravel aquifer is overlain by about 83 feet of soil described as clay or hardpan. The static water level in the well is reported to be at the ground surface.

4. Guy Abbey Well (NE ¼ of NE ¼ of NE ¼ of Section 21, Township 20N, Range 4E):

Located approximately 485 feet north and crossgradient from the subject site. The street address of the well is not given. The well was driven to a depth of 12 feet in the relatively-shallow Puyallup Valley water table aquifer. The soils are described as "soil and sand." The static water level in the well is reported to be at a depth of 10 feet.

The driller's log indicates that the well was constructed in 1944. The purpose of the well is not given. We were unable to determine if the well is still in use. Due to its shallow depth, it is unlikely that the well is used for domestic purposes if still operational. Based on this, we have excluded this well from further discussion.

Mr. Alex Garcia Mendoza
June 12, 2023
Revised August 1, 2023

19. Mountainview-Edgewood Water Company Well 1R (DOE Well ID AEC906) (SW ¼ of SW ¼ of Section 15, Township 20N, Range 4E):

Group A well located approximately 1,300 feet northeast and crossgradient from the subject site. The well address is 4623 Meridian E. The well was drilled to a depth of 100 feet and screened in soils described as sand, gravel, and cobbles between depths of 66.5 and 86.5 feet. The overlying soils are described as gravel, cobbles, and sand. The aquifer is underlain by soils described as till at a depth of 90 feet. The static water level in the well is reported to be at a depth of 18 feet. As indicated in the MEWC 2022 Water Quality Report, the well draws water from the RMC aquifer.

21. Mountainview-Edgewood Water Company Well (SW ¼ of SW ¼ of Section 15, Township 20N, Range 4E):

Located approximately 1,300 feet northeast and crossgradient from the subject site. The well identification number is not given. The street address of the well is not given. The well is cased to a depth of 92 feet with casing perforations made gravel and sand between 70 and 82 feet. Soils overlying the perforated depths consist predominantly of sand and gravel with soil described as clay between 5 and 22 feet. The static water level in the well is reported to be at a depth of 2.8 feet. As indicated in the MEWC 2022 Water Quality Report, the well draws water from the RMC aquifer.

We were unable to locate driller's logs for the 884-foot deep City of Puyallup Rec Center Well No. 17 (DOE Well ID AAB894) or the 98-foot deep Mountainview-Edgewood Water Company Well No. 8 (DOE Well ID ACV818) shown as Group A wells on the WSDOH SWAP map.

WELL WATER QUALITY REVIEW

We researched available water quality data for wells located within 1,300 feet of the site using the Washington State Department of Health, Office of Drinking Water (ODW) interactive web site (<https://fortress.wa.gov/doh/eh/portal/odw/si/FindWaterSystem.aspx>). Water quality data exists for three of the five wells. The results of water quality monitoring of each well are summarized below:

Mountainview-Edgewood Water Company Well 1R, Source 10 (DOE Well ID AEC906)

There are no recorded exceedances in samples collected from this well. Total coliform has been present in samples collected from the distribution system.

Mountainview-Edgewood Water Company Well 8, Source 8 (DOE Well ID AEC906)

There are no recorded exceedances in samples collected from this well. Total coliform has been present in samples collected from the distribution system.

DeChaux Mutual Water (DOE Well ID AEF399)

There are no recorded exceedances in samples collected from this well. Total coliform has been present in samples collected from the distribution system.

DISCUSSION

The four domestic water wells located within 1,300 feet of the site are completed in the RMC aquifer below depths ranging between 66.5 and 241 feet. The recorded static water levels in these wells are between the ground surface and a depth of 18 feet, indicating the RMC aquifer has a vertical flow gradient at the well locations. Additionally, the RMC aquifer at three of the four well locations is overlain by soils described as clay and silt or hardpan. Considering these hydrogeologic conditions, it is our opinion that the planned site development would not result in significant adverse impacts to the water quality or recharge of the RMC aquifer.

The relatively-shallow groundwater conditions at the site are consistent with the Puyallup Valley water table aquifer. Based on our review, there are no wells within 1,300 feet of the site that draw from the Puyallup Valley water table aquifer for domestic purposes. However, the shallow water table aquifer does contribute to support of the downgradient surface water features and other critical areas identified on Figure 3.

Potential impacts of the planned site development to the shallow water table aquifer include localized shallow construction dewatering, if necessary, and a decrease of permeable surface area at the site, which may impact shallow aquifer recharge currently occurring at the site by way of infiltration. However, we expect that the proposed stormwater pond would discharge into the existing storm sewer system that runs to the west along Todd Road NW and discharges to the wetland adjacent to Wapato Creek on the west side of 4th Street NW. In our opinion, the on-site stormwater quality treatment and discharge to the existing storm sewer system would adequately mitigate any potential adverse impacts to current on-site groundwater recharge and support of downgradient surface water features and wetland areas. In our opinion, any construction dewatering would have no impact on downgradient surface water features and wetland areas if the dewatering system is discharged to the existing storm sewer system. We expect that City of Puyallup notification and submittal of a temporary construction dewatering (TCD) plan for City of Puyallup review and approval would be required prior to construction.

In our opinion, the potential for adverse impacts to on-site and downgradient surface water features resulting from erosion and sedimentation during construction would be adequately mitigated with proper implementation and maintenance of BMPs for erosion prevention and sedimentation control outlined in the project construction stormwater pollution prevention plan (SWPPP).

In our opinion, potential hazards associated with the use of equipment fuels and lubricants at the site during construction would be adequately mitigated with proper implementation and maintenance of BMPs for spill prevention and recovery of hazardous materials during construction outlined in the project SWPPP.

Potential post-development impacts to groundwater at the site would be in the form of trace petroleum hydrocarbons and trace metals from roadway and parking area runoff, and typical landscape products in the form of fertilizers, pesticides, and other landscaping chemicals. It is not expected that any deleterious substances and hazardous materials used by site maintenance and landscape subcontractors would be stored on site or used in significant amounts.

In our opinion, specific recommendations for storage or handling of typical volumes of these materials for landscape and maintenance purposes, in typical residential volumes, is not warranted. Additionally, trace petroleum products and many common pesticides are readily degradable in the natural environment when dilute, and metals and pesticides are typically filtered by sorption in the upper portion of the soil column.

Potential impacts to site groundwater from a spill or leak from the permanent diesel-fueled backup generator can be adequately mitigated by implementing source control best management practices (BMPs) for fueling at dedicated stations (and above-ground and underground fuel storage facilities) as outlined in Volume IV, Chapter 6 of the 2019 *Stormwater Management Manual for Western Washington*. Applicable operational BMPs would include the following:

- Prepare an emergency spill response and cleanup plan (spill plan) per S426 BMPs for Spills of Oil and Hazardous Substances.
- Train employees on the proper use of fuel dispensers and on the spill plan.
- Have a designated trained person(s) available either on site or on call at all times to implement the spill plan promptly and properly and immediately cleanup all spills.
- The person conducting the fuel transfer must be present at the fueling pump during fuel transfer, particularly at unattended or self-serve stations.
- Keep suitable cleanup materials, such as dry adsorbent materials, on site to allow prompt cleanup of a spill.
- Do not use dispersants to clean up spills or sheens unless properly removed for disposal following application. Dispersants are not allowed to enter storm drains, surface waters, treatment systems, or sanitary sewers.
- Post signs in accordance with the requirements in the Uniform Fire Code (UFC) or International Fire Code (IFC). For example, post “No Topping Off” signs (topping off gas tanks causes spillage and vents gas fumes to the air).

Applicable Structural Source Control BMPs for new fueling stations would include the following:

- Slope the concrete containment pad around the fuel tank toward drains; either trench drains, catch basins and/or a dead-end sump. The slope of the drains shall not be less than 1 percent (Section 7901.8 of the UFC, Section 5703.6.8 of the IFC).
- Drains from containment pads must have a normally closed shutoff valve. The valve may be opened to convey contaminated stormwater to oil removal treatment such as an API or CP oil/water separator (see V-13 Oil and Water Separator BMPs), catch basin insert, or equivalent treatment, and then to a basic treatment BMP (as described in III-1.2 Choosing Your Runoff Treatment BMPs) or to a sanitary sewer, if approved by the sewer authority. Discharges from treatment systems to storm sewer or surface water or to the ground must not display ongoing or recurring visible sheen and must not contain a significant amount of oil and grease.
- The spill control capacity must be sized in compliance with Section 7901.8 of the UFC. The spill control capacity may be acquired by either an underground system including a sump, or an above ground containment area consisting of a containment pad with berms.

Mr. Alex Garcia Mendoza
June 12, 2023
Revised August 1, 2023

- The fueling island may be designed as a spill containment pad with a sill or berm raised to a minimum of four inches (per Section 7901.8 of the UFC) to prevent the runoff of spilled liquids and to prevent run-on of stormwater from the surrounding area. All stormwater collected on the containment pad must discharge to treatment with a normally closed valve downstream of the treatment.
- The fueling pad must be paved with Portland cement concrete, or equivalent. Asphalt pavement is not considered an equivalent material.

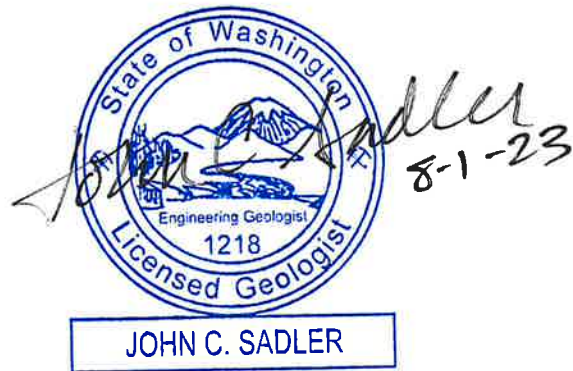
Based on our review, and provided appropriate BMPs are implemented as discussed above, it is our opinion that the use of a permanent diesel-fueled emergency generator at the site would not result in any significant adverse impacts to water quality of the shallow water table aquifer.

We trust the information presented is sufficient for your current needs. If you have any questions or require additional information, please call.

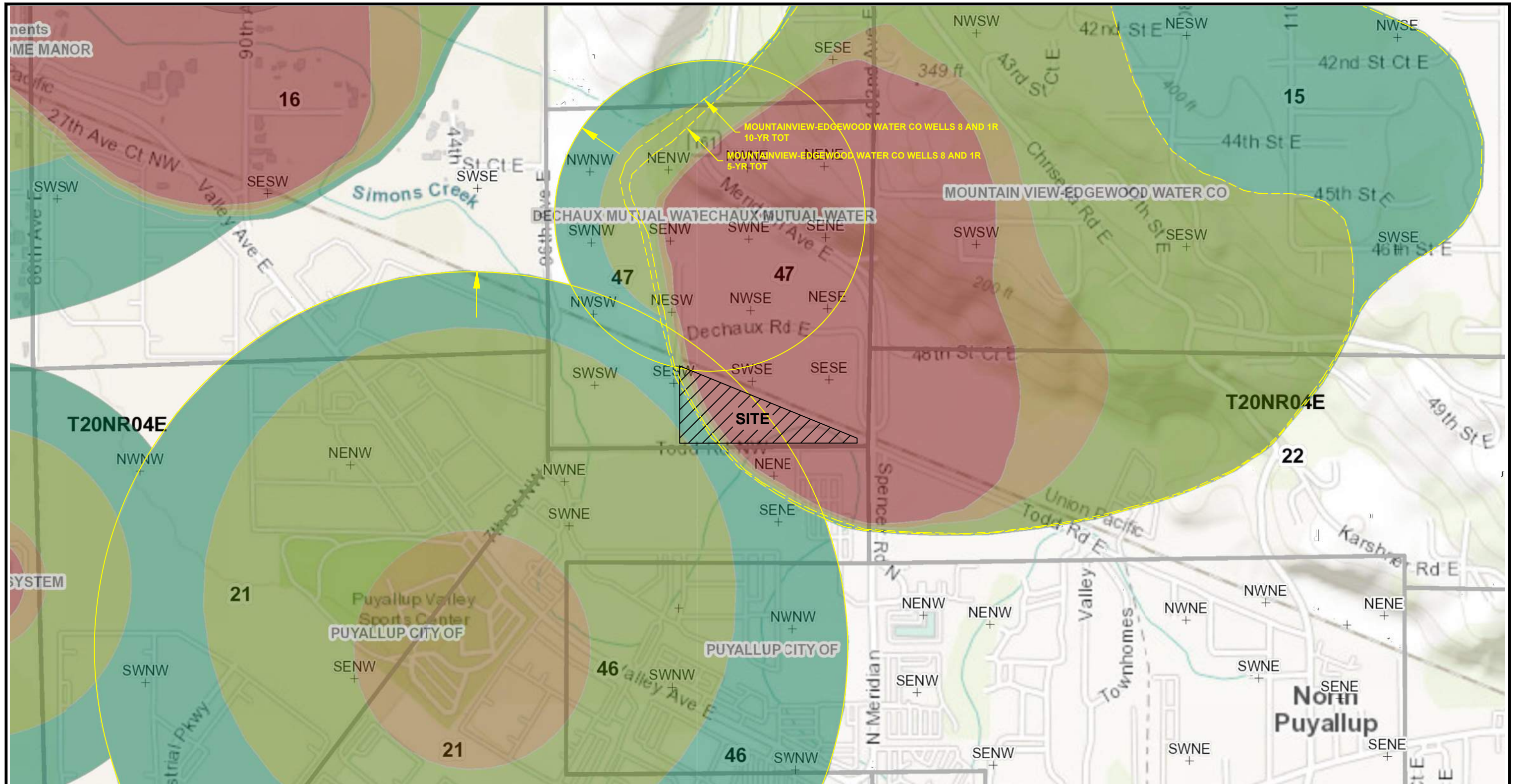
Sincerely yours,
TERRA ASSOCIATES, INC.



John C. Sadler, L.E.G., L.H.G.
Project Manager/Senior Engineering Geologist







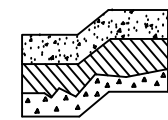
- Encl:
- Figure 1 – Wellhead Protection Zones Map
 - Figure 2 – Vicinity Map
 - Figure 3 – Other Critical Areas Map
 - Figure 4 – Proposed Development Plan
 - Figure 5 – Exploration Location Plan
 - Figure 6 – Surficial Geologic Map
 - Figure 7 – WSDOE Well Location Map
 - Appendix A – Boring Logs and CPT Plots
 - Appendix B – DOE Well Details and Driller’s Logs



REFERENCE: WSDOH SWAP (MAY 2023)

LEGEND:

-  GROUP A SYSTEM 6-MO TIME-OF-TRAVEL ZONE
-  GROUP A SYSTEM 1-YR TIME-OF-TRAVEL ZONE
-  GROUP A SYSTEM 5-YR TIME-OF-TRAVEL ZONE
-  GROUP A SYSTEM 10-YR TIME-OF-TRAVEL ZONE



Terra Associates, Inc.
 Consultants in Geotechnical Engineering
 Geology and
 Environmental Earth Sciences

WELLHEAD PROTECTION ZONES MAP
 PSE OPERATIONAL TRAINING CENTER
 PUYALLUP, WASHINGTON

Proj. No.T-8829

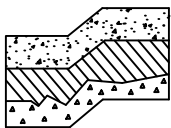
Date AUG 2023

Figure 1



REFERENCE: WSDOT GEOPORTAL

NOT TO SCALE



Terra Associates, Inc.

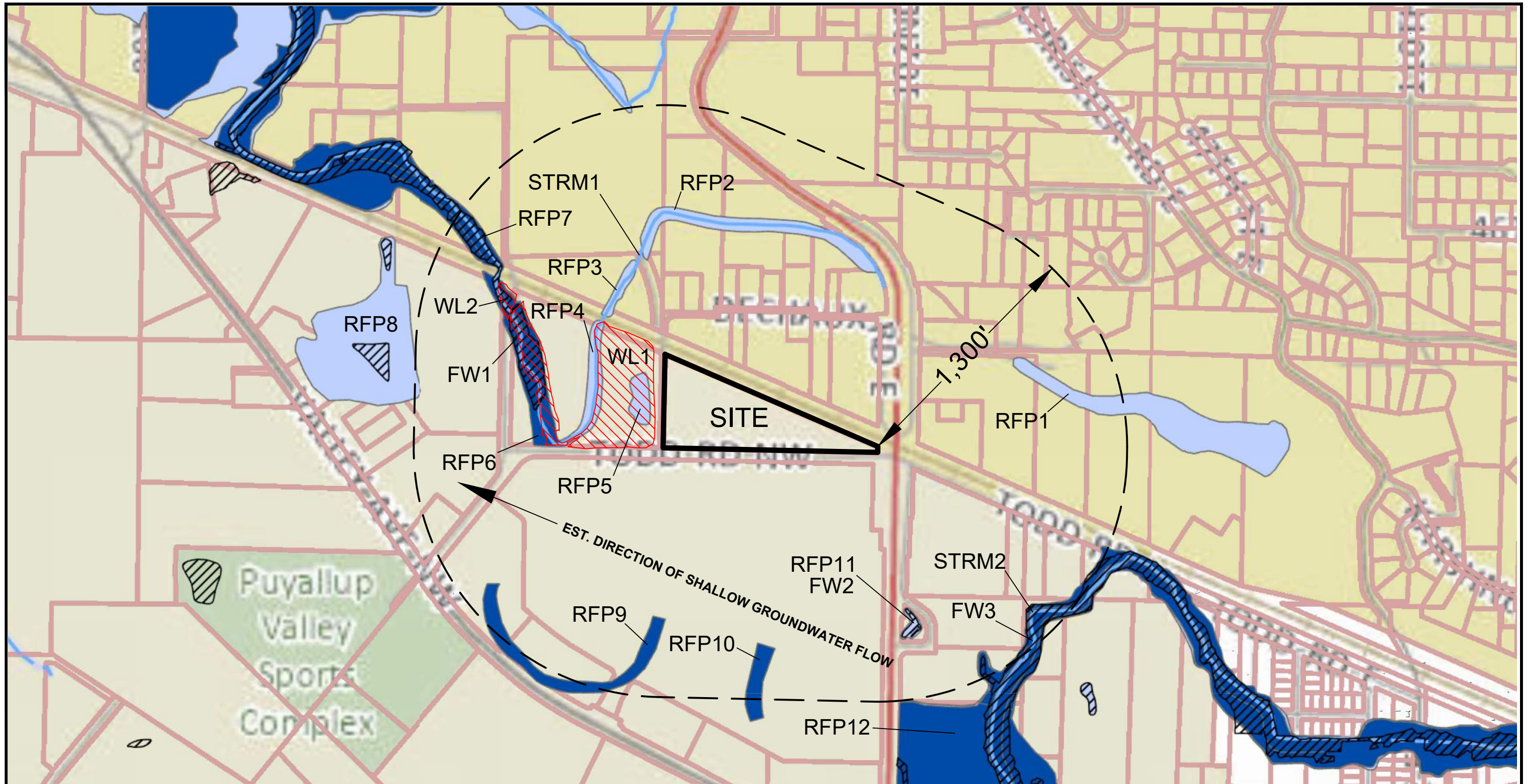
Consultants in Geotechnical Engineering
Geology and
Environmental Earth Sciences

VICINITY MAP
PSE OPERATIONAL TRAINING CENTER
PUYALLUP, WASHINGTON

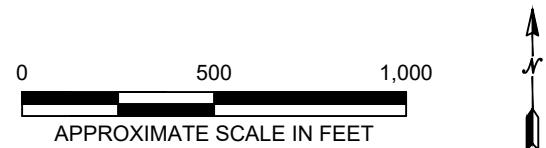
Proj. No. T-8829

Date AUG 2023





Figure 2

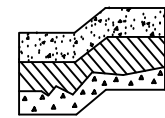


REFERENCES: PIERCE COUNTY PUBLIC GIS
CITY OF PUYALLUP GIS



LEGEND:

-  WL WETLAND (CITY OF PUYALLUP)
-  RFP REGULATED FLOODPLAIN
-  FW FLOODWAY
-  STRM STREAM



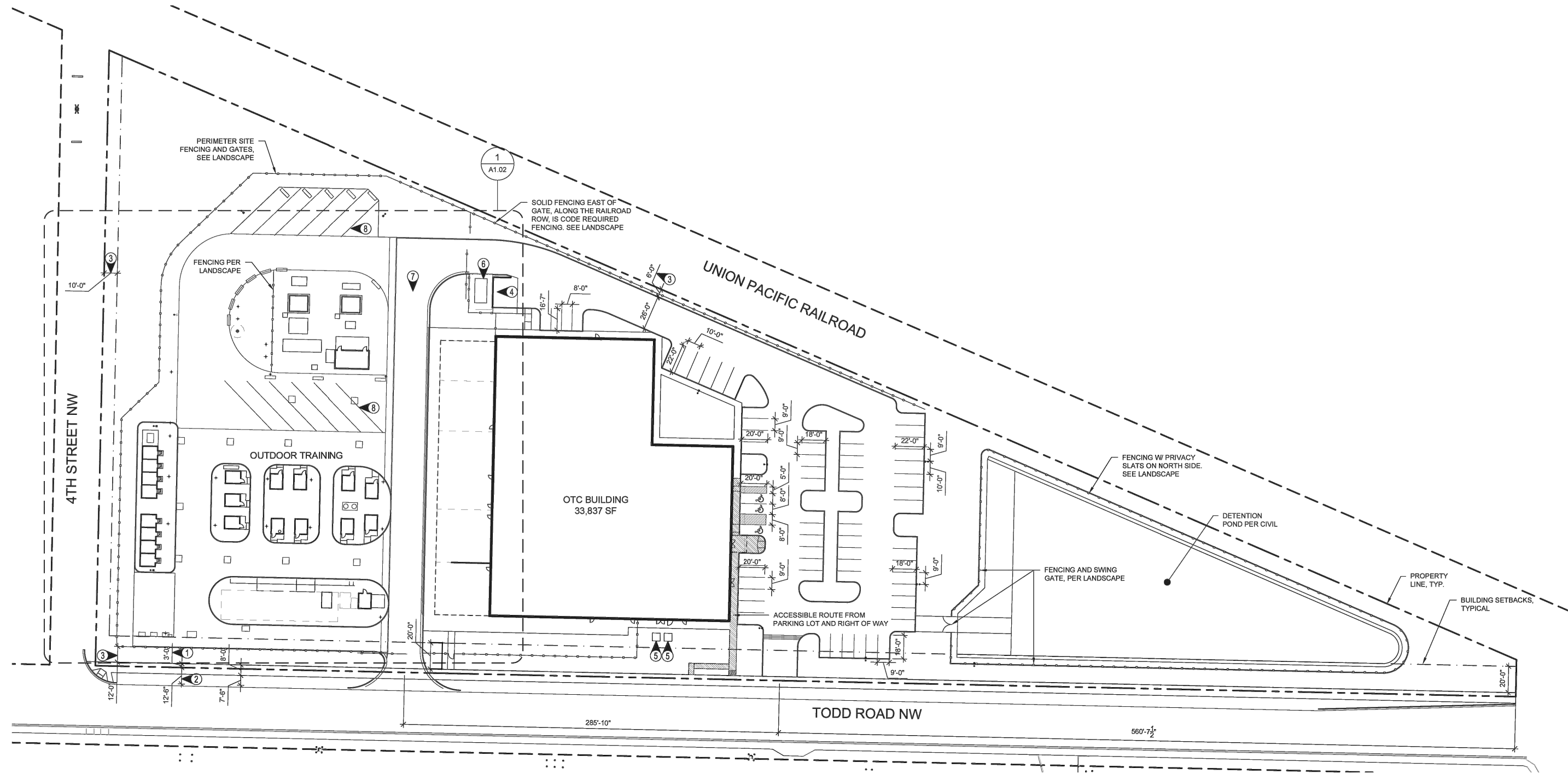
Terra Associates, Inc.
Consultants in Geotechnical Engineering
Geology and
Environmental Earth Sciences

OTHER CRITICAL AREAS MAP
PSE OPERATIONAL TRAINING CENTER
PUYALLUP, WASHINGTON

Proj. No.T-8829

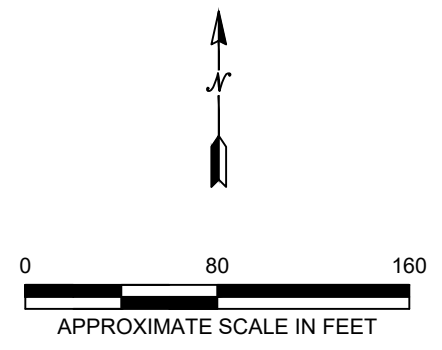
Date AUG 2023

Figure 3



NOTE:
 THIS SITE PLAN IS SCHEMATIC. ALL LOCATIONS AND DIMENSIONS ARE APPROXIMATE. IT IS INTENDED FOR REFERENCE ONLY AND SHOULD NOT BE USED FOR DESIGN OR CONSTRUCTION PURPOSES.

REFERENCE:
 ZERVAS (7-21-2023)



Terra Associates, Inc.
 Consultants in Geotechnical Engineering
 Geology and
 Environmental Earth Sciences



**PROPOSED DEVELOPMENT PLAN
 PSE OPERATIONAL TRAINING CENTER
 PUJALLUP, WASHINGTON**

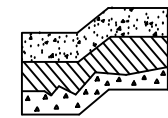
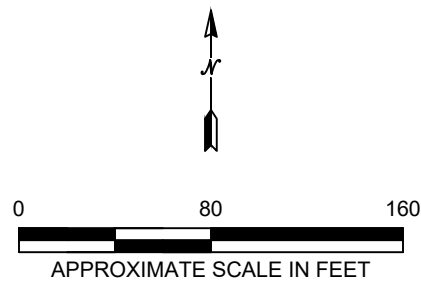
Proj. No.T-8829	Date AUG 2023	Figure 4
-----------------	---------------	----------



NOTE:
THIS SITE PLAN IS SCHEMATIC. ALL LOCATIONS AND DIMENSIONS ARE APPROXIMATE. IT IS INTENDED FOR REFERENCE ONLY AND SHOULD NOT BE USED FOR DESIGN OR CONSTRUCTION PURPOSES.

REFERENCE:
PIERCE COUNTY PUBLIC GIS

LEGEND:
 APPROXIMATE BORING LOCATION
 APPROXIMATE CPT LOCATION



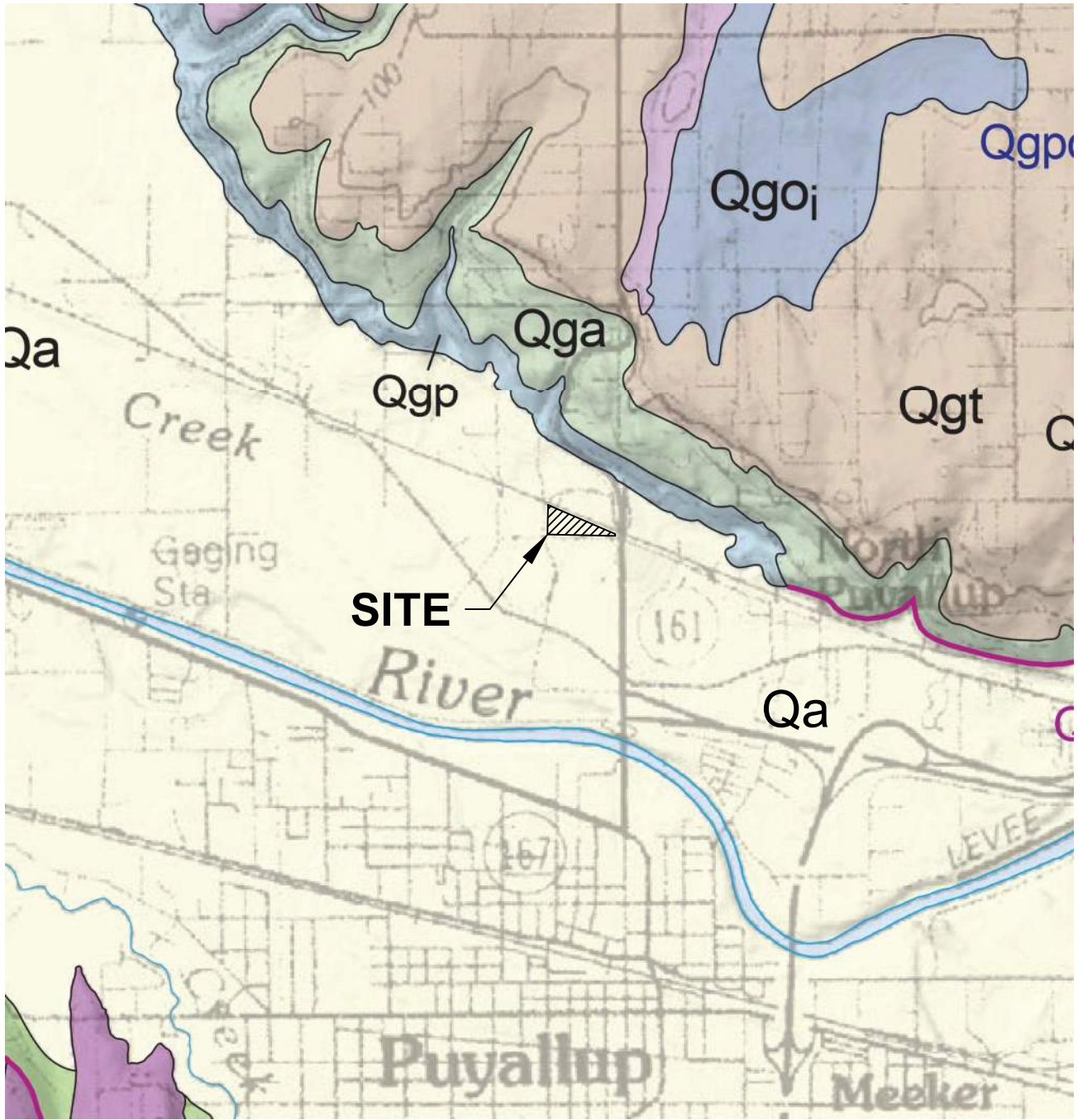
Terra Associates, Inc.
 Consultants in Geotechnical Engineering
 Geology and
 Environmental Earth Sciences

EXPLORATION LOCATION PLAN
 PSE OPERATIONAL TRAINING CENTER
 PUYALLUP, WASHINGTON

Proj. No.T-8829

Date AUG 2023

Figure 5



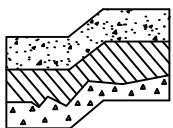
LEGEND:

- Qa** - ALLUVIUM (HOLOCENE)
- Qgo_j** - VASHON RESSIONAL OUTWASH - ICE-CONTACT DEPOSITS
- Qgt** - VASHON TILL
- Qga** - VASHON ADVANCE OUTWASH
- Qgp** - PRE-FRASER CONTINENTAL GLACIAL DRIFT



NOT TO SCALE

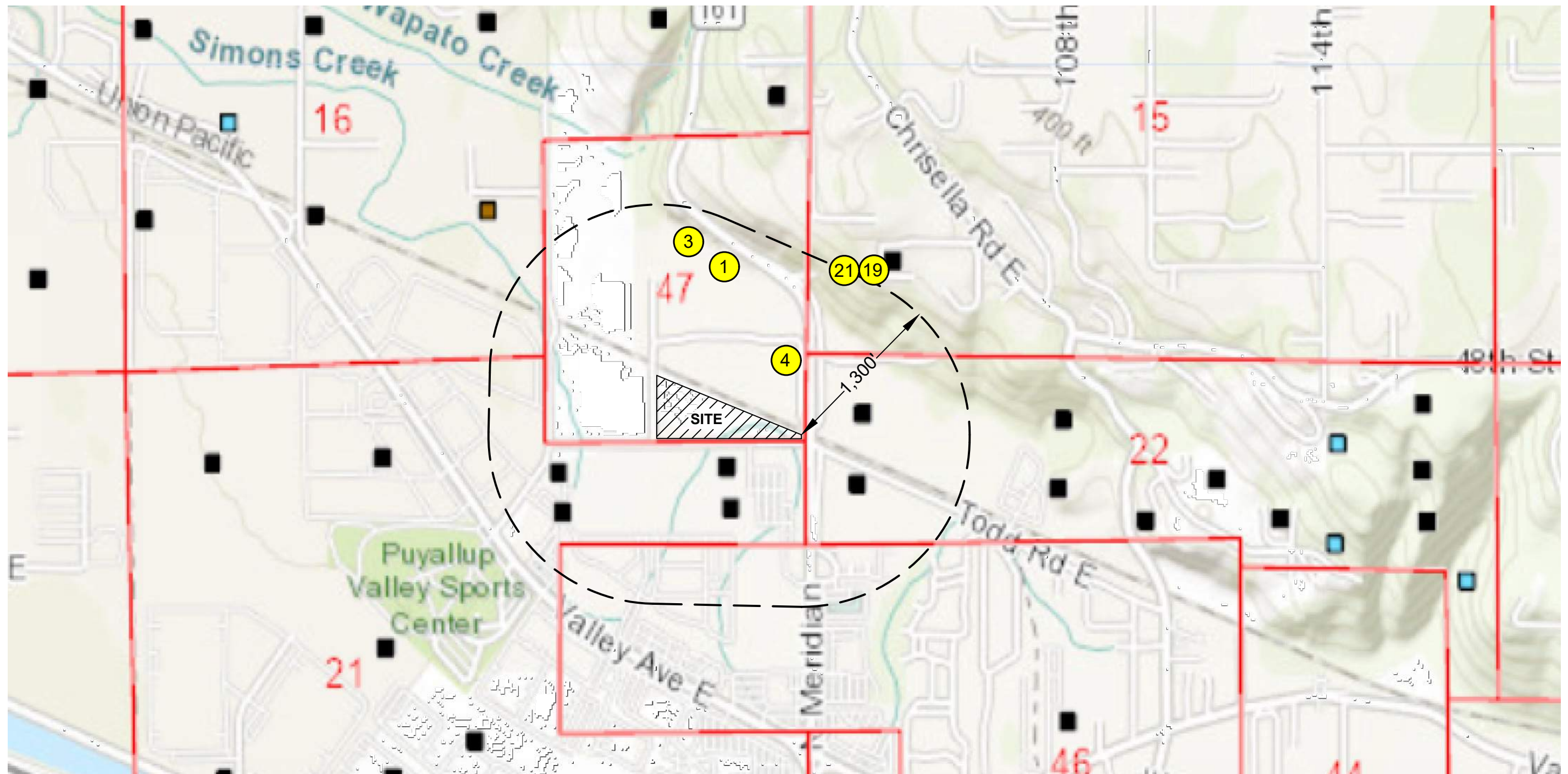
REFERENCE: GEOLOGIC MAP OF THE TACOMA 1:100,000 SCALE QUADRANGLE, WASHINGTON, 2015



Terra Associates, Inc.
 Consultants in Geotechnical Engineering
 Geology and
 Environmental Earth Sciences

**SURFICIAL GEOLOGIC MAP
 PSE OPERATIONAL TRAINING CENTER
 PUYALLUP, WASHINGTON**

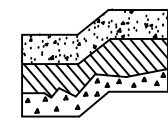
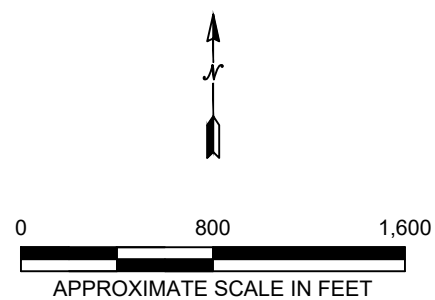
Proj. No.T-8829	Date AUG 2023	Figure 6
-----------------	---------------	----------



REFERENCE: WSDOE WATER RESOURCES PROGRAM - WELL LOCATOR WEBSITE

LEGEND:

- ① WULF WELL
- ③ DECHAUX WELL
- ④ ABBEY WELL
- ⑱ MOUNTAINVIEW-EDGEWOOD WELL
- ⑳ MOUNTAINVIEW-EDGEWOOD WELL



Terra Associates, Inc.
 Consultants in Geotechnical Engineering
 Geology and
 Environmental Earth Sciences

WSDOE WELL LOCATION MAP
 PSE OPERATIONAL TRAINING CENTER
 PUYALLUP, WASHINGTON

Proj. No.T-8829

Date AUG 2023

Figure 7

APPENDIX A
BORING LOGS AND CPT PLOTS

LOG OF BORING NO. B-1

Figure No. A-2

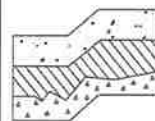
Project: PSE Operational Training Facility **Project No:** T-8829 **Date Drilled:** November 17, 2022

Client: Trammel Crow Company **Driller:** BoreTec **Logged By:** MJX

Location: Puyallup, Washington **Depth to Groundwater:** 4.5 ft **Approx. Elev:** NA

Depth (ft)	Sample Interval	Soil Description	Consistency/ Relative Density	SPT (N) Blows / foot			Moisture Content (%)
				10	30	50	
0		Blackish-gray silty SAND, fine to coarse sand, moist to wet, trace rootlets, occasional silt seam. (SM)	Loose				
~3				5			20.4
~4.5				5			29.1
~8				4			29.0
10		Blackish-gray SAND with silt, fine to coarse sand, wet, trace small organic fragments. (SP-SM)					
~10							7
		Test Boring terminated at approximately 10 feet. Groundwater seepage observed at approximately 4.5 feet.					
15							

NOTE: This borehole log has been prepared for geotechnical purposes. This information pertains only to this boring location and should not be interpreted as being indicative of other areas of the site



Terra Associates, Inc.
 Consultants in Geotechnical Engineering
 Geology and
 Environmental Earth Sciences

LOG OF BORING NO. B-2

Figure No. A-3

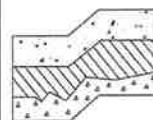
Project: PSE Operational Training Facility Project No: T-8829 Date Drilled: November 17, 2022

Client: Trammel Crow Company Driller: BoreTec Logged By: MJX

Location: Puyallup, Washington Depth to Groundwater: 4.5 ft Approx. Elev: NA

Depth (ft)	Sample Interval	Soil Description	Consistency/ Relative Density	SPT (N) Blows / foot			Moisture Content (%)
				10	30	50	
0		Blackish-gray SAND, fine to medium sand, moist, trace rootlets, occasional sandy silt seam. (SP)	Loose				10.1
5		Gray sandy SILT, fine sand, wet, occasional clayey silt layer, occasional rootlet. (ML)					
		Gray clayey SILT, wet, trace rootlets, interbedded sand seams. (ML)	Soft				52.3
10		Blackish-gray SAND, fine to coarse sand, wet, interbedded silt seams. (SP)	Stiff				
		Blackish-gray SAND, fine to coarse sand, wet, interbedded silt seams. (SP)	Loose				27.5
		Test Boring terminated at approximately 10 feet. Groundwater seepage observed at approximately 4.5 feet.					
15							

NOTE: This borehole log has been prepared for geotechnical purposes. This information pertains only to this boring location and should not be interpreted as being indicative of other areas of the site



Terra Associates, Inc.
 Consultants in Geotechnical Engineering
 Geology and Environmental Earth Sciences

LOG OF BORING NO. B-3

Figure No. A-4

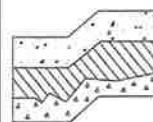
Project: PSE Operational Training Facility Project No: T-8829 Date Drilled: November 17, 2022

Client: Trammel Crow Company Driller: BoreTec Logged By: MJX

Location: Puyallup, Washington Depth to Groundwater: 4.5 ft Approx. Elev: NA

Depth (ft)	Sample Interval	Soil Description	Consistency/ Relative Density	SPT (N) Blows / foot			Moisture Content (%)	
				10	30	50		
0		Gray SILT, moist, mottled, occasional rootlet, occasional sand seam. (ML)	Medium Stiff				5	35.4
5		Gray clayey SILT, wet, occasional rootlet. (ML)	Soft				2	36.7
10		Blackish-gray SAND with silt, fine to coarse sand, wet, occasional small organic fragment, occasional clayey silt seam. (SP-SM)	Loose				5	27.3
10		Test Boring terminated at approximately 10 feet. Groundwater seepage observed at approximately 4.5 feet.					6	29.0
15								

NOTE: This borehole log has been prepared for geotechnical purposes. This information pertains only to this boring location and should not be interpreted as being indicative of other areas of the site



Terra Associates, Inc.
 Consultants in Geotechnical Engineering
 Geology and
 Environmental Earth Sciences

LOG OF BORING NO. B-4

Figure No. A-5

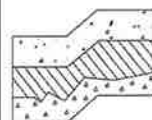
Project: PSE Operational Training Facility Project No: T-8829 Date Drilled: November 17, 2022

Client: Trammel Crow Company Driller: BoreTec Logged By: MJX

Location: Puyallup, Washington Depth to Groundwater: 4.5 ft Approx. Elev: NA

Depth (ft)	Sample Interval	Soil Description	Consistency/ Relative Density	SPT (N) Blows / foot			Moisture Content (%)	
				10	30	50		
0		Gray SILT, moist, generally mottled, localized oxidized laminations, occasional rootlet, occasional charcoal inclusion. (ML)	Soft				38.7	
5		Blackish-gray to gray clayey SILT, wet, mottled, occasional rootlet, occasional sand with silt layer. (ML)						2
		Interbedded sand seams observed	Medium Stiff				8	31.9
		Blackish-gray SAND, fine to coarse sand, wet, trace gravel, occasional silt seam. (SP)	Loose				7	23.7
10		Test Boring terminated at approximately 10 feet. Groundwater seepage observed at approximately 4.5 feet.						24.8
15								

NOTE: This borehole log has been prepared for geotechnical purposes. This information pertains only to this boring location and should not be interpreted as being indicative of other areas of the site



Terra Associates, Inc.
 Consultants in Geotechnical Engineering
 Geology and Environmental Earth Sciences

LOG OF BORING NO. B-5

Figure No. A-6

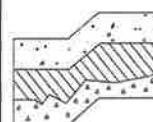
Project: PSE Operational Training Facility Project No: T-8829 Date Drilled: November 17, 2022

Client: Trammel Crow Company Driller: BoreTec Logged By: MJX

Location: Puyallup, Washington Depth to Groundwater: 4.5 ft Approx. Elev: NA

Depth (ft)	Sample Interval	Soil Description	Consistency/ Relative Density	SPT (N) Blows / foot			Moisture Content (%)	
				10	30	50		
0		Alternating layers of brownish-gray silty SAND and sandy SILT, fine to medium sand, moist, mottled, trace rootlets. (SM/ML)	Very Loose				3	27.7
5		Gray clayey SILT, wet, mottled, trace sand, occasional rootlet. (ML)	Soft				2	40.6
			Medium Stiff				6	36.8
		Blackish-gray SAND with silt, fine to medium sand, wet, occasional silt seam. (SP-SM)	Loose					25.2
10		Blackish-gray SAND, fine to coarse sand, wet, occasional silt layer. (SP)	Very Loose				3	26.1
		Test Boring terminated at approximately 10 feet. Groundwater seepage observed at approximately 4.5 feet.						
15								

NOTE: This borehole log has been prepared for geotechnical purposes. This information pertains only to this boring location and should not be interpreted as being indicative of other areas of the site



Terra Associates, Inc.
 Consultants in Geotechnical Engineering
 Geology and
 Environmental Earth Sciences

LOG OF BORING NO. B-6

Figure No. A-7

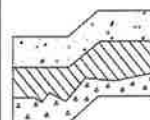
Project: PSE Operational Training Facility Project No: T-8829 Date Drilled: November 17, 2022

Client: Trammel Crow Company Driller: BoreTec Logged By: MJX

Location: Puyallup, Washington Depth to Groundwater: 6 ft Approx. Elev: NA

Depth (ft)	Sample Interval	Soil Description	Consistency/ Relative Density	SPT (N) Blows / foot			Moisture Content (%)
				10	30	50	
0		Brownish-gray silty SAND, fine sand, moist, occasional rootlet, occasional clayey silt layer. (SM)	Loose	•		6	19.2
5		Alternating layers of silty SAND and sandy SILT, fine sand, moist to wet, mottled, occasional sand seam. (SM/ML)					
		Gray SILT, moist to wet, mottled, interbedded sandy silt layers, occasional sand seam. (ML)	Soft	•		4	33.7
10		Gray clayey SILT, moist to wet, oxidized laminations. (ML)					
15							

NOTE: This borehole log has been prepared for geotechnical purposes. This information pertains only to this boring location and should not be interpreted as being indicative of other areas of the site



Terra Associates, Inc.
 Consultants in Geotechnical Engineering
 Geology and
 Environmental Earth Sciences

LOG OF BORING NO. B-7

Figure No. A-8

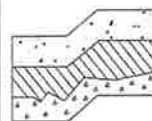
Project: PSE Operational Training Facility Project No: T-8829 Date Drilled: November 16, 2022

Client: Trammel Crow Company Driller: BoreTec Logged By: MJX

Location: Puyallup, Washington Depth to Groundwater: 6 ft Approx. Elev: NA

Depth (ft)	Sample Interval	Soil Description	Consistency/ Relative Density	SPT (N) Blows / foot			Moisture Content (%)	
				10	30	50		
0		Brownish-gray silty SAND, fine sand, moist to wet, slightly mottled, trace sandy silt seams, occasional rootlet. (SM)	Very Loose				3	18.9
5							5	38.0
		Brownish-gray SAND with silt, fine to medium sand, wet, trace silt layers. (SP-SM)	Loose				8	29.0
		Gray clayey SILT, moist, trace small organic fragments, interbedded sand layers. (ML) <i>*Numerous organic PEAT inclusions observed in upper 6 inches of sample*</i>	Soft				3	42.2
		Blackish-gray SAND with silt, fine to medium sand, wet, occasional silt layer. (SP-SM)	Loose				9	29.3
							17	29.1
		Gray SILT, moist, occasional small organic fragment, interbedded and inundated sand layers. (ML)	Very Stiff				19	27.9
		Test Boring terminated at approximately 20 feet, Groundwater seepage observed at approximately 6 feet.						
25								

NOTE: This borehole log has been prepared for geotechnical purposes. This information pertains only to this boring location and should not be interpreted as being indicative of other areas of the site



Terra Associates, Inc.
 Consultants in Geotechnical Engineering
 Geology and
 Environmental Earth Sciences

LOG OF BORING NO. B-8

Figure No. A-9

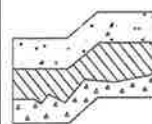
Project: PSE Operational Training Facility Project No: T-8829 Date Drilled: November 16, 2022

Client: Trammel Crow Company Driller: BoreTec Logged By: MJX

Location: Puyallup, Washington Depth to Groundwater: 10 ft Approx. Elev: NA

Depth (ft)	Sample Interval	Soil Description	Consistency/ Relative Density	SPT (N) Blows / foot			Moisture Content (%)	
				10	30	50		
0		FILL: Gray silty GRAVEL with sand, fine to coarse sand, fine to coarse gravel, wet, trace rootlets. (GM)	Loose	•			5	5.6
5		Brownish-gray clayey SILT, moist, mottled, trace sand seams, occasional rootlet. (ML)	Medium Stiff	•			5	30.4 16.8
		Brownish-gray SAND with silt, fine to medium sand, moist, occasional silt layer. (SP-SM)		•			5	36.0
10		Gray sandy SILT, fine to medium sand, moist, mottled, trace sand seams. (ML)	Loose	•				
		Blackish-gray SAND with silt, fine to coarse sand, wet, occasional silt layer. (SP-SM)	Medium Dense	•			11	26.4
		Gray SILT, moist to wet, trace sand seams, trace fine gravel. (ML)	Medium Stiff	•			5	44.4
15		Blackish-gray SAND with silt, fine to medium sand, wet, occasional fine gravel. (SP-SM)		•			13	28.6
20		Dark gray SAND with silt, fine to medium sand, wet, occasional fine gravel, interbedded silt layers. (SP-SM)	Medium Dense	•			20	27.8
25		Blackish-gray SAND with silt, fine to medium sand, wet, interbedded silt layers. (SP-SM)		•			24	27.6
30			Dense	•			31	24.2
35		Test Boring terminated at approximately 30 feet. Groundwater seepage observed at approximately 10 feet.						

NOTE: This borehole log has been prepared for geotechnical purposes. This information pertains only to this boring location and should not be interpreted as being indicative of other areas of the site



Terra Associates, Inc.
 Consultants in Geotechnical Engineering
 Geology and
 Environmental Earth Sciences

LOG OF BORING NO. B-9

Figure No. A-10

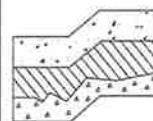
Project: PSE Operational Training Facility Project No: T-8829 Date Drilled: November 16, 2022

Client: Trammel Crow Company Driller: BoreTec Logged By: MJX

Location: Puyallup, Washington Depth to Groundwater: 7.5 ft Approx. Elev: NA

Depth (ft)	Sample Interval	Soil Description	Consistency/ Relative Density	SPT (N) Blows / foot			Moisture Content (%)	
				10	30	50		
0		Brownish-gray silty SAND, fine sand, moist, occasional gravel, occasional rootlet, interbedded sand seams, interbedded silt seams. (SM)	Loose	•			6	16.3
5				•			5	17.8
7.5		Gray sandy SILT, fine sand, moist to wet, mottled, interbedded and inundated sand seams. (ML)	Medium Stiff	•			7	33.5
10		Gray clayey SILT, moist to wet, occasional localized mottling, occasional localized oxidized lamination. (ML)		•			6	42.8
12		Gray SILT, wet, occasional small organic fragment. (ML)	Loose	•			4	40.4
15		Blackish-gray SAND with silt, fine to medium sand, wet, interbedded silt layers. (SP-SM)		•			9	30.7
20		Light brown organic PEAT, wet, fibrous, trace sand. (PT) (Partially decomposed tree trunk)	Very Loose	•			3	211.4
25		Gray sandy SILT, fine to medium sand, wet, interbedded silty sand layers. (ML)	Medium Dense		•		26	33.2
30		Gray SILT with sand, fine to medium sand, wet, interbedded silty sand layers. (ML)		Stiff	•			13
30		Test Boring terminated at approximately 30 feet. Groundwater seepage observed at approximately 7.5 feet.						
35								

NOTE: This borehole log has been prepared for geotechnical purposes. This information pertains only to this boring location and should not be interpreted as being indicative of other areas of the site



Terra Associates, Inc.
 Consultants in Geotechnical Engineering
 Geology and
 Environmental Earth Sciences

LOG OF BORING NO. B-10

Figure No. A-11

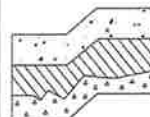
Project: PSE Operational Training Facility Project No: T-8829 Date Drilled: November 16, 2022

Client: Trammel Crow Company Driller: BoreTec Logged By: MJX

Location: Puyallup, Washington Depth to Groundwater: 10 ft Approx. Elev: NA

Depth (ft)	Sample Interval	Soil Description	Consistency/ Relative Density	SPT (N) Blows / foot			Moisture Content (%)	
				10	30	50		
0		Grayish-brown sandy SILT, fine sand, moist, localized mottling, localized oxidized laminations, trace small organic fragments, interbedded fine sand layers. (ML)	Loose	•			7	12.9
5				•			5	23.3
		Brownish-gray SAND, fine to medium sand, moist, occasional silt seam. (SP)		•			6	11.3
10		Gray SILT, moist to wet, oxidized laminations, trace small organic fragments, interbedded and inundated sand layers. (ML)	Medium Stiff	•			4	36.8
			Stiff	•			10	35.2
15		Gray SAND with silt, fine to medium sand, wet, interbedded silt layers. (SP-SM)	Medium Dense	•			14	28.4
20		Gray sandy SILT, fine sand, moist to wet, occasional silt seam, occasional wood waste inclusion. (ML)		•			13	32.6
		Test Boring terminated at approximately 20 feet. Groundwater seepage observed at approximately 10 feet.						
25								

NOTE: This borehole log has been prepared for geotechnical purposes. This information pertains only to this boring location and should not be interpreted as being indicative of other areas of the site



Terra Associates, Inc.
 Consultants in Geotechnical Engineering
 Geology and
 Environmental Earth Sciences

LOG OF BORING NO. B-11

Figure No. A-12

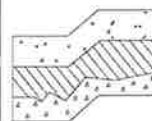
Project: PSE Operational Training Facility Project No: T-8829 Date Drilled: November 16, 2022

Client: Trammel Crow Company Driller: BoreTec Logged By: MJX

Location: Puyallup, Washington Depth to Groundwater: 10 ft Approx. Elev: NA

Depth (ft)	Sample Interval	Soil Description	Consistency/ Relative Density	SPT (N) Blows / foot			Moisture Content (%)	Observ. Well
				10	30	50		
0		Brownish-gray SILT with sand, fine sand, moist, mottled, trace rootlets. (ML)	Medium Stiff			4	36.6	
5		Brownish-gray silty SAND, fine sand, moist to wet, interbedded silt with sand layers. (SM)	Loose			4	24.3	
		Gray SAND with silt, fine to medium sand, moist to wet, interbedded and mottled silty sand and silt layers. (SP-SM)				5	28.2	
10						4	30.7	
		Gray SILT, moist to wet, interbedded and inundated sand with silt layers. (ML)	Stiff			8	46.2	
15		Gray SAND with silt, fine to medium sand, wet, occasional silt layer. (SP-SM)	Medium Dense			11	31.2	
20		<p>Test Boring terminated at approximately 15 feet.</p> <p>Groundwater seepage observed at approximately 10 feet.</p> <p>Boring converted to groundwater monitoring well with monument no. BNV 571.</p>						

NOTE: This borehole log has been prepared for geotechnical purposes. This information pertains only to this boring location and should not be interpreted as being indicative of other areas of the site



Terra Associates, Inc.
 Consultants in Geotechnical Engineering
 Geology and
 Environmental Earth Sciences

LOG OF BORING NO. B-12

Figure No. A-13

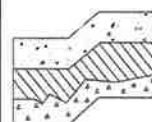
Project: PSE Operational Training Facility Project No: T-8829 Date Drilled: November 16, 2022

Client: Trammel Crow Company Driller: BoreTec Logged By: MJX

Location: Puyallup, Washington Depth to Groundwater: 9 ft Approx. Elev: NA

Depth (ft)	Sample Interval	Soil Description	Consistency/ Relative Density	SPT (N) Blows / foot			Moisture Content (%)
				10	30	50	
0		FILL: Gray GRAVEL with silt and sand, fine to coarse sand, fine to coarse gravel, moist, scattered rootlets. (GP-GM)	Loose			8	9.1
5		Gray SILT, moist, mottled, trace sand seams. (ML)	Stiff			11	32.5
		Brown SAND, fine to coarse sand, moist, (SP)					9.6
		Gray SAND with silt, fine to coarse sand, moist to wet, trace gravel, occasional silt seam. (SP-SM)				10	16.3
10		Blackish-gray SAND, fine to coarse sand, wet, trace fine gravel, trace silt. (SP)	Medium Dense			11	24.7
						12	18.7
15			Loose			9	19.8
		Test Boring terminated at approximately 15 feet. Groundwater seepage observed at approximately 9 feet.					
20							

NOTE: This borehole log has been prepared for geotechnical purposes. This information pertains only to this boring location and should not be interpreted as being indicative of other areas of the site



Terra Associates, Inc.
 Consultants in Geotechnical Engineering
 Geology and
 Environmental Earth Sciences

LOG OF BORING NO. B-13

Figure No. A-14

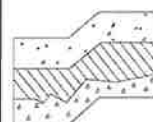
Project: PSE Operational Training Facility Project No: T-8829 Date Drilled: November 16, 2022

Client: Trammel Crow Company Driller: BoreTec Logged By: MJX

Location: Puyallup, Washington Depth to Groundwater: 10 ft Approx. Elev: NA

Depth (ft)	Sample Interval	Soil Description	Consistency/ Relative Density	SPT (N) Blows / foot			Moisture Content (%)	Observ. Well
				10	30	50		
0		FILL: Gray GRAVEL with silt and sand, fine to coarse sand, fine to coarse gravel, moist. (GP-GM)	Medium Dense			14	9.9	
5		Brownish-gray sandy SILT, fine sand, moist, mottled, occasional gravel, occasional rootlet. (ML)	Loose			4	22.3	
10		Gray SILT, moist to wet, oxidized laminations, trace sand, occasional small organic fragment, interbedded sand with silt and silty sand layers. (ML)	Medium Stiff			8	20.1	
10						5	36.5	
10						8	26.5	
15		Blackish-gray SAND with silt, fine to medium sand, wet, occasional fine gravel, interbedded silty sand and silt layers. (SP-SM)	Medium Dense			10	31.2	
20						29	25.0	
25						16	26.6	
30						24	24.9	
35		Test Boring terminated at approximately 30 feet. Groundwater seepage observed at approximately 10 feet. Boring converted to groundwater monitoring well with monument no. BNV 572.						

NOTE: This borehole log has been prepared for geotechnical purposes. This information pertains only to this boring location and should not be interpreted as being indicative of other areas of the site



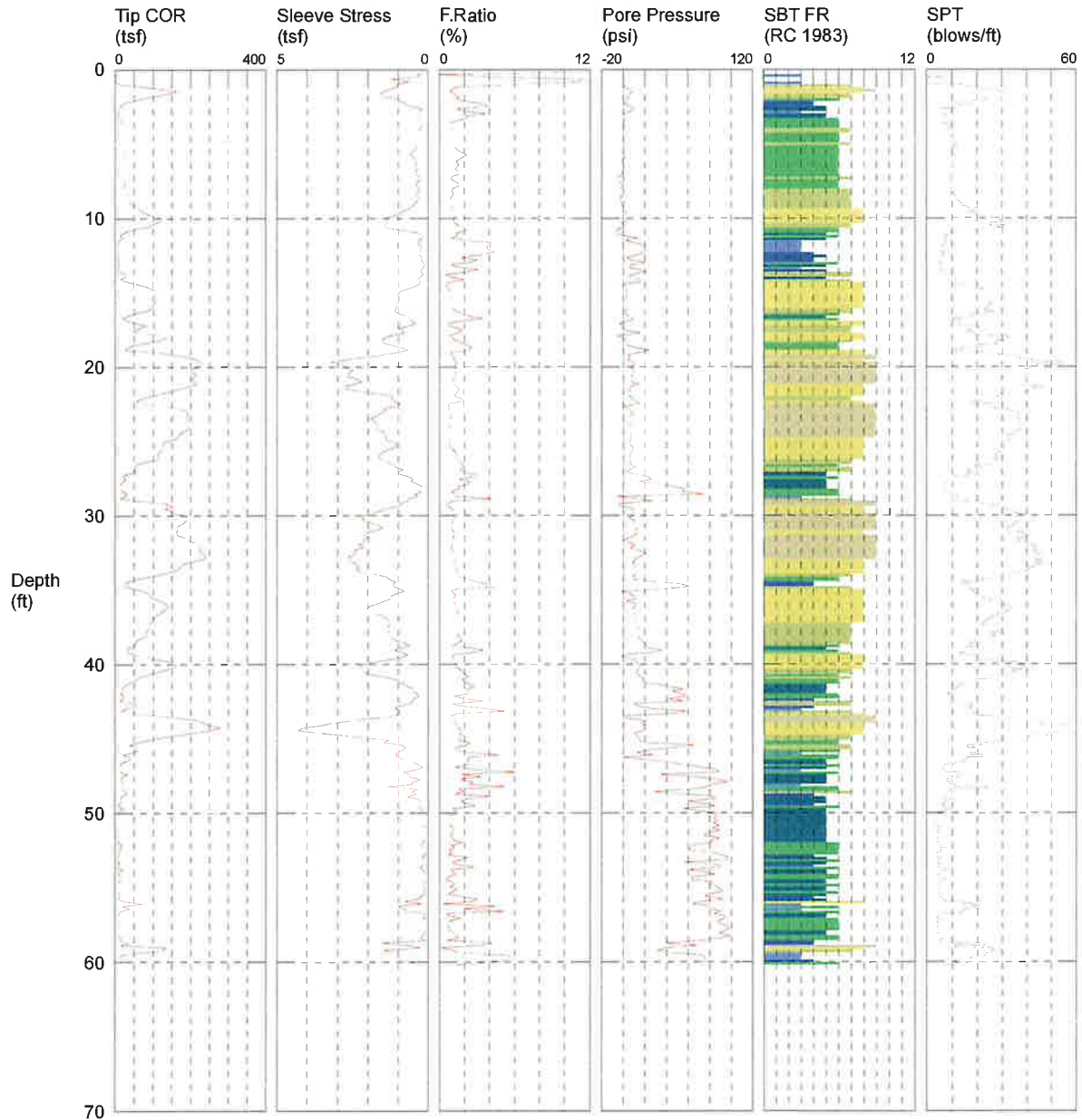
Terra Associates, Inc.
 Consultants in Geotechnical Engineering
 Geology and
 Environmental Earth Sciences



CPT-01

CPT CONTRACTOR: In Situ Engineering
 CUSTOMER: Terra Associates
 LOCATION: Puyallup
 JOB NUMBER: T-8829
 COMMENT: PSE Operational Training Center

OPERATOR: Okbay
 CONE ID: DDG1351
 TEST DATE: 11/18/2022 11:40:03 AM
 PREDRILL: 0 ft
 BACK FILL: 20% Grout + Bentonite Chips
 SURFACE PATCH: None



TOTAL DEPTH: 60.203 ft

DEPTH INTERVAL: 0.050 m

- | | | | |
|--------------------------|-----------------------------|----------------------------|--------------------------------|
| 1 sensitive fine grained | 4 silty clay to clay | 7 silty sand to sandy silt | 10 gravelly sand to sand |
| 2 organic material | 5 clayey silt to silty clay | 8 sand to silty sand | 11 very stiff fine grained (*) |
| 3 clay | 6 sandy silt to clayey silt | 9 sand | 12 sand to clayey sand (*) |

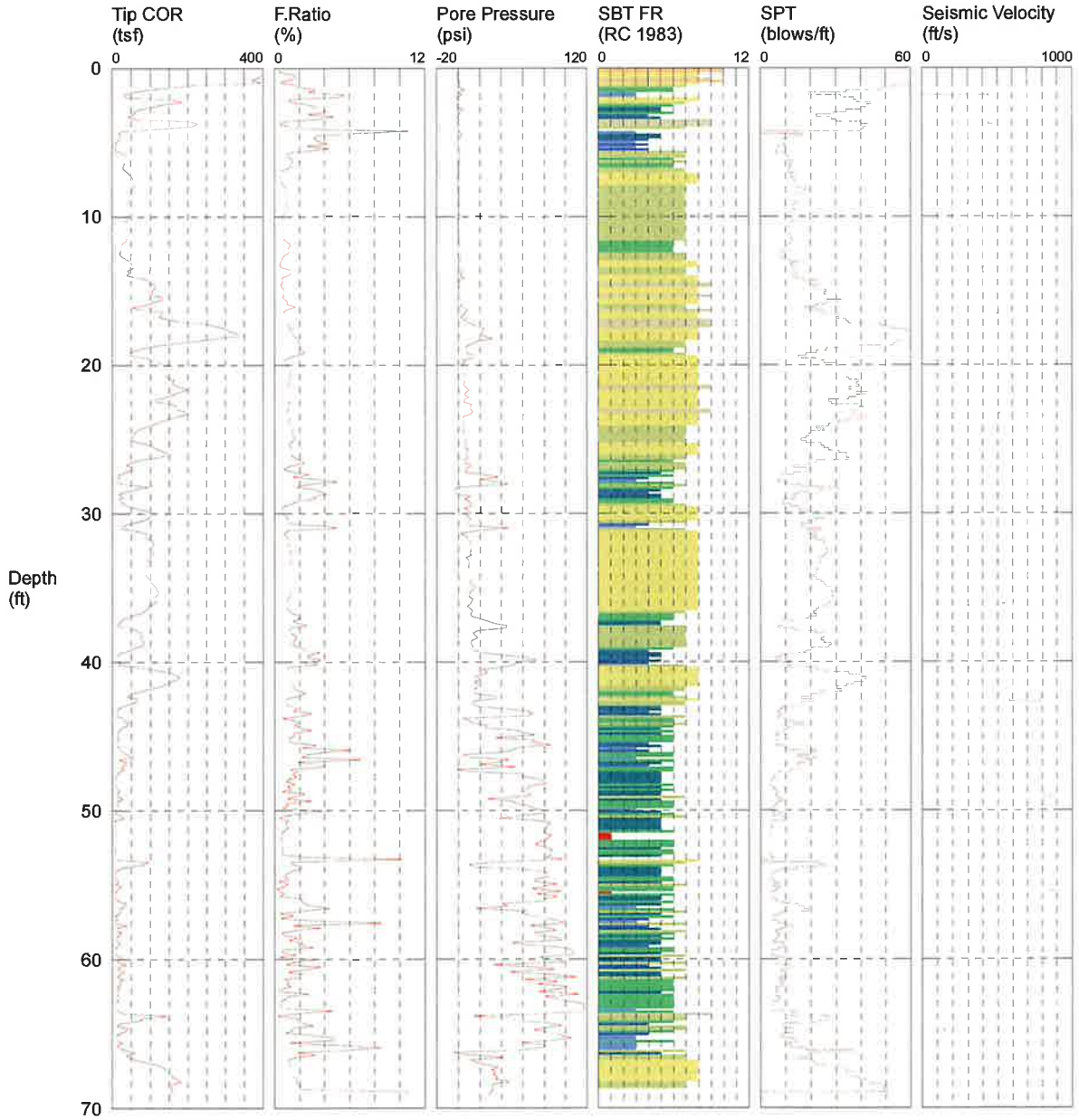
*SBT/SPT CORRELATION: UBC-1983



CPT-02

CPT CONTRACTOR: In Situ Engineering
 CUSTOMER: Terra Associates
 LOCATION: Puyallup
 JOB NUMBER: T-8829
 COMMENT: PSE Operational Training Center
 COMMENT:

OPERATOR: Okbay
 CONE ID: DDG1351
 TEST DATE: 11/18/2022 1:29:19 PM
 PREDRILL: 0 ft
 BACK FILL: 20% Grout + Bentonite Chips
 SURFACE PATCH: None



- | | | | |
|--------------------------|-----------------------------|----------------------------|--------------------------------|
| 1 sensitive fine grained | 4 silty clay to clay | 7 silty sand to sandy silt | 10 gravelly sand to sand |
| 2 organic material | 5 clayey silt to silty clay | 8 sand to silty sand | 11 very stiff fine grained (*) |
| 3 clay | 6 sandy silt to clayey silt | 9 sand | 12 sand to clayey sand (*) |
- *SBT/SPT CORRELATION: UBC-1983

APPENDIX B
DOE WELL DETAILS AND DRILLER'S LOGS



Well Report Search Results

[Edit Search Criteria](#)
[New Search](#)

Search Criteria Used:

- Left Coordinate: 1191492
- Right Coordinate: 1195874
- Top Coordinate: 689450
- Bottom Coordinate: 693757
- Well Type: Water

[Download all 25 images](#)

[Download all 25 data records](#)

[Print this page](#)

[Need Help](#)

Displaying well reports 1 → 25 of 25

Sort results by:

Well Owner Name ▼

Results Per Page:

100 ▼

#	Well Details	Location Details
1.	<p>View PDF</p> <p>Well Owner: BURTON WALF</p> <p>Well Tag ID: <i>L Driller's log</i></p> <p>Notice of Intent Number: <i>SAYS WOLF</i></p> <p>Group Number: Not Applicable</p> <p>Well Report ID: 44836</p> <p>Well Diameter: 6 in.</p> <p>Well Depth: 245 ft.</p>	<p>Tax Parcel Number:</p> <p>Well Address:</p> <p>County: PIERCE</p> <p>Public Land Survey: SE-SE / S-16 / T-20-N / R-04-E</p> <p>Well Type: Water / Subtype: Unknown</p> <p>Well Completion Date: 10-03-1979</p> <p>Well Report Received Date: 11-06-1979</p>
2.	<p>View PDF</p> <p>Well Owner: CHARLES & PHYLLIS SMITH</p> <p>Well Tag ID: ACK068 <i>MIS LOCATED</i></p> <p>Notice of Intent Number: W072034</p> <p>Group Number: Not Applicable</p> <p>Well Report ID: 55825</p> <p>Well Diameter: 6 in. <i>OUTSIDE SEARCH RADIUS</i></p> <p>Well Depth: 114 ft.</p>	<p>Tax Parcel Number:</p> <p>Well Address: 3802 84TH AVE CT E</p> <p>County: PIERCE <i>Sec 17</i></p> <p>Public Land Survey: NE-SE / S-16 / T-20-N / R-04-E</p> <p>Well Type: Water / Subtype: Unknown</p> <p>Well Completion Date: 08-15-1996</p> <p>Well Report Received Date:</p>
3.	<p>View PDF</p> <p>Well Owner: FRANK DECHAUX</p> <p>Well Tag ID: AEF399</p> <p>Notice of Intent Number:</p> <p>Group Number: Not Applicable</p> <p>Well Report ID: 46923</p> <p>Well Diameter: 8 in.</p> <p>Well Depth: 100 ft.</p>	<p>Tax Parcel Number: 0420164088</p> <p>Well Address:</p> <p>County: PIERCE</p> <p>Public Land Survey: SE-SE / S-16 / T-20-N / R-4-E</p> <p>Well Type: Water / Subtype: Unknown</p> <p>Well Completion Date: 08-08-1978</p> <p>Well Report Received Date: 08-25-1978</p>



4.		Well Owner: GUY ABBEY Well Tag ID: Notice of Intent Number: Group Number: Not Applicable Well Report ID: 47603 Well Diameter: 1 in. Well Depth: 12 ft.	Tax Parcel Number: Well Address: County: PIERCE Public Land Survey: NE-NE / S-21 / T-20-N / R-04-E Well Type: Water / Subtype: Unknown Well Completion Date: Well Report Received Date:
5.		Well Owner: JEANETTE HUBBARD Well Tag ID: BAC440 Notice of Intent Number: W210491 Group Number: Not Applicable Well Report ID: 667934 Well Diameter: 6 in. Well Depth: 131 ft.	Tax Parcel Number: 0420175002 Well Address: 3906 84TH AVE CT E County: PIERCE Public Land Survey: NW-NE / S-21 / T-20-N / R-04-E Well Type: Water / Subtype: Unknown Well Completion Date: 07-14-2010 Well Report Received Date: 08-18-2010
6.		Well Owner: JR. WUNELL CONSTRUCTION Well Tag ID: Notice of Intent Number: Group Number: Not Applicable Well Report ID: 49259 Well Diameter: 6 in. Well Depth: 52 ft.	Tax Parcel Number: Well Address: VALLEY AVE, County: PIERCE Public Land Survey: SW-NW / S-22 / T-20-N / R-04-E Well Type: Water / Subtype: Unknown Well Completion Date: 08-31-1993 Well Report Received Date: 04-06-1994
7.		Well Owner: KASSEL CONSTRUCTION / CITY PUYALLUP Well Tag ID: Notice of Intent Number: 042758 Group Number: Not Applicable Well Report ID: 49325 Well Diameter: 2 in. Well Depth: 0 ft.	Tax Parcel Number: Well Address: 902 VALLEY AVE County: PIERCE Public Land Survey: SW-NE / S-21 / T-20-N / R-04-E Well Type: Water / Subtype: Unknown Well Completion Date: 10-15-1998 Well Report Received Date: 12-24-1998
8.		Well Owner: Lattitude Development Well Tag ID: BKT976 Notice of Intent Number: DE02055 Group Number: Not Applicable Well Report ID: 1657838 Well Diameter: 1.5 in. Well Depth: 20 ft.	Tax Parcel Number: Well Address: 102 Todd Rd NE County: PIERCE Public Land Survey: NW-NW / S-22 / T-20-N / R-04-E Well Type: Water / Subtype: Dewatering Well Completion Date: 07-25-2017 Well Report Received Date: 08-29-2017
9.		Well Owner: Lattitude Development Well Tag ID: BKT977 Notice of Intent Number: DE02055 Group Number: Not Applicable Well Report ID: 1657839 Well Diameter: 1.5 in. Well Depth: 20 ft.	Tax Parcel Number: Well Address: 102 Todd Rd NE County: PIERCE Public Land Survey: NW-NW / S-22 / T-20-N / R-04-E Well Type: Water / Subtype: Dewatering Well Completion Date: 07-25-2017 Well Report Received Date: 08-29-2017
10.		Well Owner: Lattitude Development Well Tag ID: BKT978 Notice of Intent Number: DE02055 Group Number: Not Applicable Well Report ID: 1657840 Well Diameter: 1.5 in. Well Depth: 20 ft.	Tax Parcel Number: Well Address: 102 Todd Rd NE County: PIERCE Public Land Survey: NW-NW / S-22 / T-20-N / R-04-E Well Type: Water / Subtype: Dewatering Well Completion Date: 07-25-2017 Well Report Received Date: 08-29-2017



MIS LOCATED

OUTSIDE SEARCH RADIUS

IRRIGATION WELL

Well DECOMMISSION LOG

DEWATERING WELL

SEC 17





11.	View PDF	Well Owner: Lattitude Development Well Tag ID: BKT979 Notice of Intent Number: DE02055 Group Number: Not Applicable Well Report ID: 1657841 Well Diameter: 1.5 in. Well Depth: 20 ft.	Tax Parcel Number: Well Address: 102 Todd Rd NE County: PIERCE Public Land Survey: NW-NW / S-22 / T-20-N / R-04-E Well Type: Water / Subtype: Dewatering Well Completion Date: 07-25-2017 Well Report Received Date: 08-29-2017
12.	View PDF	Well Owner: Lattitude Development Well Tag ID: BKT980 Notice of Intent Number: DE02055 Group Number: Not Applicable Well Report ID: 1657842 Well Diameter: 1.5 in. Well Depth: 20 ft.	Tax Parcel Number: Well Address: 102 Todd Rd NE County: PIERCE Public Land Survey: NW-NW / S-22 / T-20-N / R-04-E Well Type: Water / Subtype: Dewatering Well Completion Date: 07-25-2017 Well Report Received Date: 08-29-2017
13.	View PDF	Well Owner: Lattitude Development Well Tag ID: BKT981 Notice of Intent Number: DE02055 Group Number: Not Applicable Well Report ID: 1657843 Well Diameter: 1.5 in. Well Depth: 20 ft.	Tax Parcel Number: Well Address: 102 Todd Rd NE County: PIERCE Public Land Survey: NW-NW / S-22 / T-20-N / R-04-E Well Type: Water / Subtype: Dewatering Well Completion Date: 07-25-2017 Well Report Received Date: 08-29-2017
14.	View PDF	Well Owner: Lattitude Development Well Tag ID: BKT982 Notice of Intent Number: DE02055 Group Number: Not Applicable Well Report ID: 1657844 Well Diameter: 1.5 in. Well Depth: 20 ft.	Tax Parcel Number: Well Address: 102 Todd Rd NE County: PIERCE Public Land Survey: NW-NW / S-22 / T-20-N / R-04-E Well Type: Water / Subtype: Dewatering Well Completion Date: 07-25-2017 Well Report Received Date: 08-29-2017
15.	View PDF	Well Owner: Lattitude Development Well Tag ID: BKT983 Notice of Intent Number: DE02055 Group Number: Not Applicable Well Report ID: 1657845 Well Diameter: 1.5 in. Well Depth: 20 ft.	Tax Parcel Number: Well Address: 102 Todd Rd NE County: PIERCE Public Land Survey: NW-NW / S-22 / T-20-N / R-04-E Well Type: Water / Subtype: Dewatering Well Completion Date: 07-25-2017 Well Report Received Date: 08-29-2017
16.	View PDF	Well Owner: Lattitude Development Well Tag ID: BKT984 Notice of Intent Number: DE02055 Group Number: Not Applicable Well Report ID: 1657846 Well Diameter: 1.5 in. Well Depth: 20 ft.	Tax Parcel Number: Well Address: 102 Todd Rd NE County: PIERCE Public Land Survey: NW-NW / S-22 / T-20-N / R-04-E Well Type: Water / Subtype: Dewatering Well Completion Date: 07-25-2017 Well Report Received Date: 08-29-2017
17.	View PDF	Well Owner: Lattitude Development Well Tag ID: BKT985 Notice of Intent Number: DE02055 Group Number: Not Applicable Well Report ID: 1657847 Well Diameter: 1.5 in. Well Depth: 20 ft.	Tax Parcel Number: Well Address: 102 Todd Rd NE County: PIERCE Public Land Survey: NW-NW / S-22 / T-20-N / R-04-E Well Type: Water / Subtype: Dewatering Well Completion Date: 07-25-2017 Well Report Received Date: 08-29-2017

18.	View PDF	Well Owner: LENA GWERDER Well Tag ID: Notice of Intent Number: Group Number: Not Applicable Well Report ID: 49765 Well Diameter: 6 in. Well Depth: 164 ft.	Tax Parcel Number: Well Address: County: PIERCE Public Land Survey: NE-SE / S-16 / T-20-N / R-04-E Well Type: Water / Subtype: Unknown Well Completion Date: 09-24-1984 Well Report Received Date: 10-30-1984
19.	View PDF	Well Owner: Mountain View Edgewood Water Co Well Tag ID: ACE906 Notice of Intent Number: Group Number: Not Applicable Well Report ID: 1915508 Well Diameter: 0 in. Well Depth: 0 ft.	Tax Parcel Number: 0420153014 Well Address: 4623 Meridan E County: PIERCE Public Land Survey: SW-SW / S-15 / T-20-N / R-4-E Well Type: Water / Subtype: Unknown Well Completion Date: Well Report Received Date:
20.	View PDF	Well Owner: MOUNTAIN VIEW-EDGEWOOD WATER CO. Well Tag ID: AEC906 Notice of Intent Number: W106915 Group Number: Not Applicable Well Report ID: 56386 Well Diameter: 16 in. Well Depth: 96 ft.	Tax Parcel Number: Well Address: County: PIERCE Public Land Survey: SW-SW / S-15 / T-20-N / R-04-E Well Type: Water / Subtype: Unknown Well Completion Date: 02-17-1999 Well Report Received Date: 03-04-1999
21.	View PDF	Well Owner: MT VIEW EDGEWOOD WATER CO Well Tag ID: Notice of Intent Number: Group Number: Not Applicable Well Report ID: 1557289 Well Diameter: 12 in. Well Depth: 94 ft.	Tax Parcel Number: Well Address: County: PIERCE Public Land Survey: SW-SW / S-15 / T-20-N / R-04-E Well Type: Water / Subtype: Unknown Well Completion Date: Well Report Received Date:
22.	View PDF	Well Owner: ROUND UP COMPANY Well Tag ID: Notice of Intent Number: 019671 Group Number: Not Applicable Well Report ID: 52462 Well Diameter: 8 in. Well Depth: 30 ft.	Tax Parcel Number: Well Address: 2200 N MERIDIAN County: PIERCE Public Land Survey: NE-NE / S-21 / T-20-N / R-04-E Well Type: Water / Subtype: Unknown Well Completion Date: 05-03-1995 Well Report Received Date: 05-15-1995
23.	View PDF	Well Owner: ROUNDUP CO., STEVE SALISBURY Well Tag ID: Notice of Intent Number: Group Number: Not Applicable Well Report ID: 276939 Well Diameter: 10 in. Well Depth: 40 ft.	Tax Parcel Number: Well Address: County: PIERCE Public Land Survey: NE-NE / S-21 / T-20-N / R-04-E Well Type: Water / Subtype: Unknown Well Completion Date: Well Report Received Date:

OUTSIDE RADIUS

CONTINUATION OF ABV LOG.



SAME LOC. AS ABV. 1953

DEWATERING WELL

DEWATERING WELL





24.		<p>Well Owner: ROUNDUP CO., STEVE SALISBURY</p> <p>Well Tag ID:</p> <p>Notice of Intent Number: <i>DEWATERING WELL</i></p> <p>Group Number: Not Applicable</p> <p>Well Report ID: 276940</p> <p>Well Diameter: 10 in.</p> <p>Well Depth: 40 ft.</p>	<p>Tax Parcel Number:</p> <p>Well Address:</p> <p>County: PIERCE</p> <p>Public Land Survey: NE-NE / S-21 / T-20-N / R-04-E</p> <p>Well Type: Water / Subtype: Unknown</p> <p>Well Completion Date:</p> <p>Well Report Received Date:</p>
25.		<p>Well Owner: TED YAGUCHI</p> <p>Well Tag ID: <i>MISLOCATED</i></p> <p>Notice of Intent Number: 065586</p> <p>Group Number: Not Applicable</p> <p>Well Report ID: 53176</p> <p>Well Diameter: 6 in.</p> <p>Well Depth: 50 ft.</p>	<p>Tax Parcel Number:</p> <p>Well Address: 4303 90TH AVE E</p> <p>County: PIERCE</p> <p>Public Land Survey: NE-SE / S-16 / T-20-N / R-04-E <i>NE of SW</i></p> <p>Well Type: Water / Subtype: Unknown</p> <p>Well Completion Date: 02-25-1991</p> <p>Well Report Received Date:</p>

Total Result Pages: 1

MISLOCATED

MISLOCATED

2

Start Card No. W072034

File Original and First Copy with Department of Ecology
Second Copy — Owner's Copy
Third Copy — Driller's Copy

WATER WELL REPORT

STATE OF WASHINGTON

UNIQUE WELL I.D. # **ACK 068**

Water Right Permit No.

(1) OWNER: Name **Charles & Phyllis Smith** Address **3802 8th Ave Ct. E. Edgewood**

(2) LOCATION OF WELL: County **Pierce** NE 1/4 SE 1/4 Sec 16 T 20 N. R. 4E W.M.

(2a) STREET ADDRESS OF WELL (or nearest address) **3802 - 8th Ave Ct E** SEC 17

(3) PROPOSED USE: Domestic Industrial Municipal
 Irrigation Test Well Other
 DeWater

(4) TYPE OF WORK: Owner's number of well (if more than one)
Abandoned New well Deepened Reconditioned
Method: Dug Bored
Cable Driven
Rotary Jetted

(5) DIMENSIONS: Diameter of well **6** inches.
Drilled **114** feet. Depth of completed well **114** ft.

(6) CONSTRUCTION DETAILS:
Casing installed: **E** Diam. from **+1** ft. to **109** ft.
Welded Diam. from _____ ft. to _____ ft.
Liner installed Diam. from _____ ft. to _____ ft.
Threaded Diam. from _____ ft. to _____ ft.

Perforations: Yes No
Type of perforator used _____
SIZE of perforations _____ in. by _____ in.
_____ perforations from _____ ft. to _____ ft.
_____ perforations from _____ ft. to _____ ft.
_____ perforations from _____ ft. to _____ ft.

Screens: Yes No
Manufacturer's Name **30415**
Type _____ Model No. _____
Diam. **5** Slot size **20** from **114** ft. to **109** ft.
Diam. _____ Slot size _____ from _____ ft. to _____ ft.

Gravel packed: Yes No Size of gravel _____
Gravel placed from _____ ft. to _____ ft.

Surface seal: Yes No To what depth? **20** ft.
Material used in seal **chip**
Did any strata contain unusable water? Yes No
Type of water? _____ Depth of strata _____
Method of sealing strata off _____

(7) PUMP: Manufacturer's Name _____
Type: _____ H.P. _____

(8) WATER LEVELS: Land-surface elevation _____ ft.
Static level **8** ft. below top of well Date **8-15-96**
Artesian pressure _____ lbs. per square inch Date _____
Artesian water is controlled by _____ (Cap, valve, etc.)

(9) WELL TESTS: Drawdown is amount water level is lowered below static level
Was a pump test made? Yes No If yes, by whom? _____
Yield: **7** gal./min. with **40** ft. drawdown after **1** hrs.

Recovery data (time taken as zero when pump turned off) (water level measured from well top to water level)
Time Water Level Time Water Level Time Water Level

Date of test _____
Bailer test **10** gal./min. with **47** ft. drawdown after **2** hrs.
Airtest _____ gal./min. with stem set at _____ ft. for _____ hrs.
Artesian flow _____ g.p.m. Date _____
Temperature of water _____ Was a chemical analysis made? Yes No

(10) WELL LOG or ABANDONMENT PROCEDURE DESCRIPTION

Formation: Describe by color, character, size of material and structure, and show thickness of aquifers and the kind and nature of the material in each stratum penetrated, with at least one entry for each change of information.

MATERIAL	FROM	TO
Brown Sandy SILT	0	20
Gray Sandy SILT	20	38
med. Sand	38	41
Sand & wood	41	54
Sand	54	57
Gray SILT	57	108
Sand	108	114

Work Started **8-13** 19**96** completed **8-15** 19**96**

WELL CONSTRUCTOR CERTIFICATION:

I constructed and/or accept responsibility for construction of this well, and its compliance with all Washington well construction standards. Materials used and the information reported above are true to my best knowledge and belief.

NAME **Holt Drilling, Inc.**
(PERSON, FIRM, OR CORPORATION) (TYPE OR PRINT)
Address **11221 Todd Rd E. Puyallup 98372**
(Signed) **Walter Peterson** License No. **587**
(WELL DRILLER)

Contractor's Registration No. **HOLTDE13606** Date **9-19** 19**96**

(USE ADDITIONAL SHEETS IF NECESSARY)

Ecology is an Equal Opportunity and Affirmative Action employer. For special accommodation needs, contact the Water Resources Program at (206) 407-6600. The TDD number is (206) 407-6006.

The Department of Ecology does NOT Warranty the Data and/or the Information on this Well Report.

Dechaux Mutual - Group A

WATER WELL REPORT
STATE OF WASHINGTON

Application No. E

Permit No. _____

(1) OWNER: Name Frank Dechaux Address 419 Dechaux Rd. SW Puyallup, Wa. 98371

(2) LOCATION OF WELL: County Pierce SE 1/4 SE 1/4 Sec. 16 T. 20 N. R. 4E W.M.

bearing and distance from section or subdivision corner

(3) PROPOSED USE: Domestic Industrial Municipal
Irrigation Test Well Other

(4) TYPE OF WORK: Owner's number of well (if more than one) 1
New well Method: Dug Bored
Deepened Cable Driven
Reconditioned Rotary Jetted

(5) DIMENSIONS: Diameter of well 8 inches
Drilled 103 ft. Depth of completed well 100 ft.

(6) CONSTRUCTION DETAILS:
Casing installed: 8 " Diam. from 0 ft. to 100 ft.
Threaded " Diam. from _____ ft. to _____ ft.
Welded " Diam. from _____ ft. to _____ ft.

Perforations: Yes No
Type of perforator used _____
SIZE of perforations _____ in. by _____ in.
_____ perforations from _____ ft. to _____ ft.
_____ perforations from _____ ft. to _____ ft.
_____ perforations from _____ ft. to _____ ft.

Screens: Yes No
Manufacturer's Name Johnson Well
Type Stainless steel Model No. _____
Diam. 8 Slot size 80 from 93 ft. to 83 ft.
Diam. _____ Slot size _____ from _____ ft. to _____ ft.

Gravel packed: Yes No Size of gravel: _____
Gravel placed from _____ ft. to _____ ft.

Surface seal: Yes No To what depth? 20 ft.
Material used in seal Bentonite
Did any strata contain unusable water? Yes No
Type of water? _____ Depth of strata _____
Method of sealing strata off _____

(7) PUMP: Manufacturer's Name Jacuzzi Bros.
Type: 5S4B HP 5

(8) WATER LEVELS: Land-surface elevation above mean sea level _____ ft.
Static level 0 ft. below top of well Date 8-8-78
Artesian pressure _____ lbs. per square inch Date _____
Artesian water is controlled by _____ (Cap, valve, etc.)

(9) WELL TESTS: Drawdown is amount water level is lowered below static level
Was a pump test made? Yes No If yes, by whom? _____
Yield: _____ gal./min. with _____ ft. drawdown after _____ hrs.

Recovery data (time taken as zero when pump turned off) (water level measured from well top to water level)

Time	Water Level	Time	Water Level	Time	Water Level

Date of test _____
Blatter test 100 gal./min. with 5 ft. drawdown after 1 hrs.
Artesian flow _____ g.p.m. Date 8-17-78
Temperature of water _____ Was a chemical analysis made? Yes No

(10) WELL LOG:

Formation: Describe by color, character, size of material and structure, and show thickness of aquifers and the kind and nature of the material in each stratum penetrated, with at least one entry for each change of formation.

MATERIAL	FROM	TO
Top soil	0	1
Clay & sand	1	3
Sea-age	3	5
Sand & clay	5	16
Hard an	16	23
Clay, sand & gravel	23	38
Gray clay	38	40
Water, reddish clay & gravel	40	83
Water, coarse sand & gravel	83	93
Gray clay clay & gravel	93	103

RECEIVED
AUG 25 1978
DEPARTMENT OF ECOLOGY
SOUTHWEST REGIONAL OFFICE

Work started 8-7 1978 Completed 8-8 1978

WELL DRILLER'S STATEMENT:

This well was drilled under my jurisdiction and this report is true to the best of my knowledge and belief.

NAME Richardson Well Drilling Co.
(Person, firm, or corporation) (Type or print)

Address P.O. Box 44408 Tacoma, Wa. 98444

[Signed] [Signature]
(Well Driller)

License No. 223-02-5500 Date 8-17 1978

The Department of Ecology does NOT warrant the data and/or the information on this Well Report



Pierce County Assessor-Treasurer's Office



Warning: Tax Payer Name Information Is Unavailable.

AEF399

Please Click One Of The Following For Details

Tax & Assessment

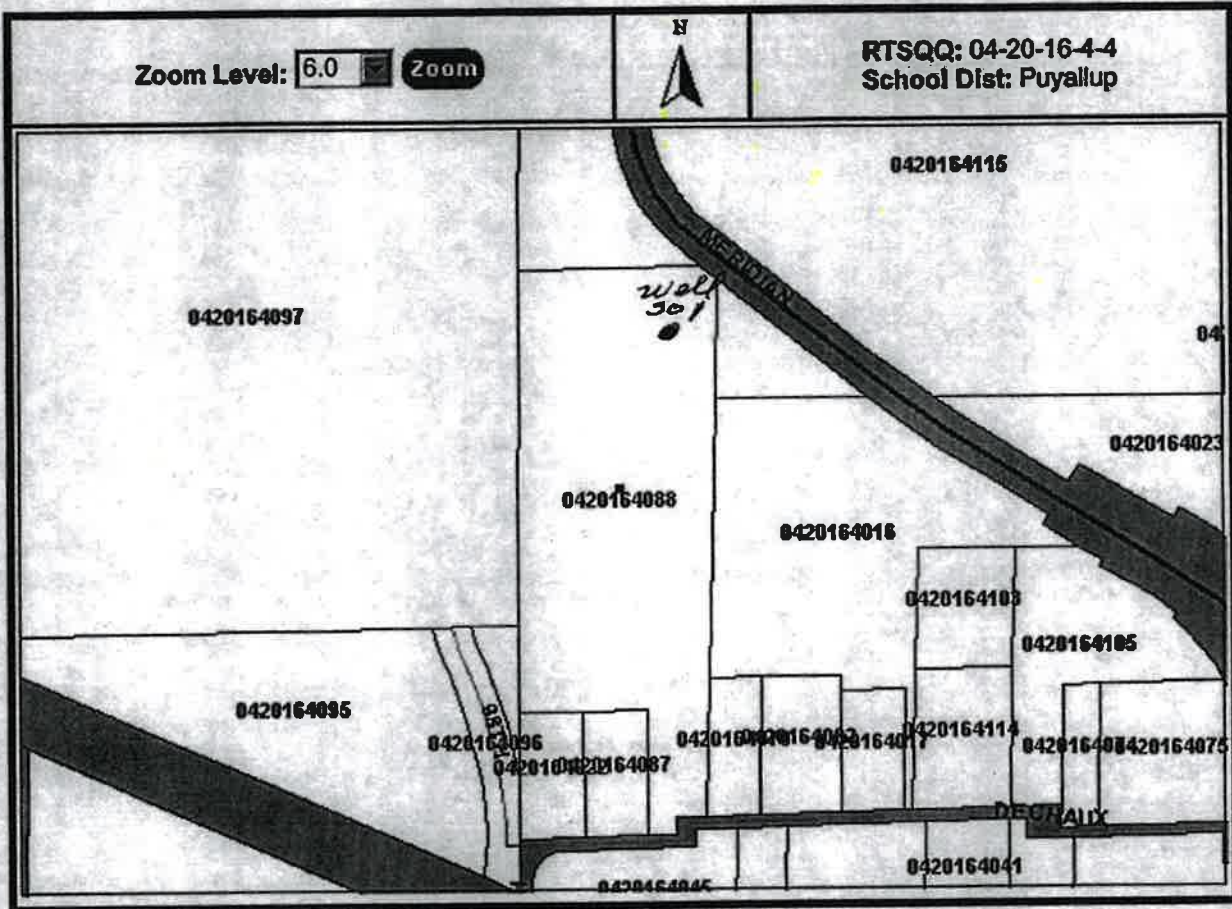
Land Characteristics

Building Characteristics

Parcel Map

Recorded Data

Back to Search



For additional mapping options, visit [Map Your Way](#)

Pierce County Assessor-Treasurer
2401 South 35th St Room 142
Tacoma, Washington 98409
(253)798-6111 or Fax (253)798-3142

I acknowledge and agree to the prohibitions listed in RCW 42.17.260(9) against releasing and/or using lists of individuals for commercial purposes.

(c) 2001 Pierce County Assessor-Treasurer

The Department of Ecology does NOT Warranty the Data and/or the Information on this Well Report



Tacoma-Pierce County Health Department

Unique Well ID Number AEP399
X Y Z 1 2 3

WELL TAGGING FORM

All shaded areas must be completed.

Date of Field Visit 3-19-99 By Matt + Scott

ADDITIONAL WELL IDENTIFIERS

Department of Health System ID Number 183507 Source # SO 1

USGS Site Identification _____

Other _____

RECORD VERIFICATION

Well Report available (please attach)

Well Report not available

Verification inconclusive

WELL OWNERSHIP, IF DIFFERENT FROM WELL REPORT

Name DECHAUX MUTUAL WATER

Street Address 9811 DECHAUX RD. E

City PLYMOUTH State WA 98371

LOCATION OF WELL, IF DIFFERENT FROM WELL REPORT

Well Address _____

City _____ County PIERCE

T. 20 N. R. 04 E. W.M. Sec. 16 SE 1/4 of the SE 1/4

Latitude 47 ° 12 ' 59.1 "

Longitude 122 ° 17 ' 48.4 "

- GPS (raw data)
- GPS (corrected)
- Topographic Map
- Survey
- Computer Generated
- Other _____

Elevation at land surface _____ feet/meters (circle one)

- Digital Altimeter
- Topographic Map
- Other _____

The Department of Ecology does NOT Warranty the Data and/or the Information on this Well Report.

Additional information, if available:

Location marked on topographic map (please attach)

Location marked on air photo (please attach)

AEF 399

Water right #

Priority Date

Circle One: Application Permit Certificate Claim Exempt

WELL CHARACTERISTICS

Physical Description of Well (size of casing, type of well, housing, etc.): *8" cased well, uncovered, in the open field*

Location of Well Identification Tag: *on the 8" casing*

Was supplemental tag needed for ease of identifying well?

NO YES

If yes, where was tag placed?

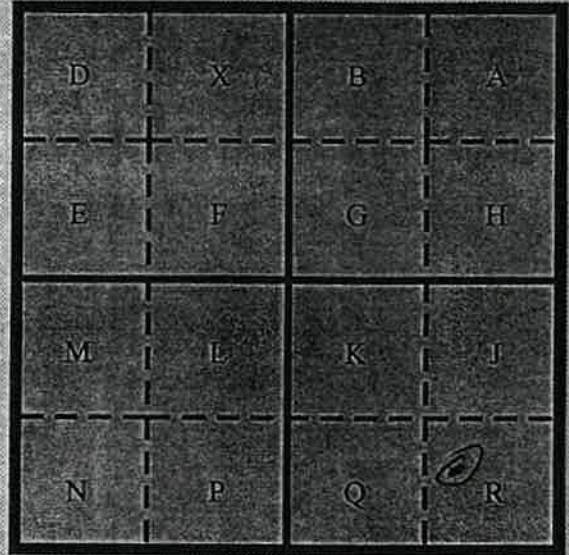
Scale 1:24,000 (1"=2,000')

Indicate the location of the well within the Section by drawing a dot at that point.

SECTION 16

TOWNSHIP 20

RANGE 04E



COMMENTS: _____

4

STATE OF WASHINGTON
DEPARTMENT OF CONSERVATION
AND DEVELOPMENT

WELL LOG

No. Decla. #165
Cert. #115-D

Date 1944, 19

Record by Guy E. Abbey

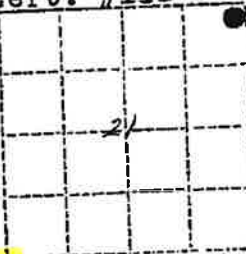
Source G. W. Decla. Claim

Location: State of WASHINGTON

County Pierce

Area

Map



NE 1/4 NE 1/4 sec. 21 T. 20 N., R. 4 E.

Drilling Co.

Address

Method of Drilling Driven Date 19

Owner Guy E. Abbey

Address Rt. 4, Box 8, Puyallup, Wash.

Land surface, datum ft. above below

CORRELATION	MATERIAL	THICKNESS (feet)	DEPTH (feet)
-------------	----------	------------------	--------------

(Transcribe driller's terminology literally but paraphrase as necessary, in parentheses. If material water-bearing, so state and record static level if reported. Give depths in feet below land-surface datum unless otherwise indicated. Correlate with stratigraphic column, if feasible. Following log of materials, list all casings, perforations, screens, etc.)

Well log:			
Soil & sand			
Dim.: 12' deep; 1 1/4" diam.			
SWL: 10 feet			
DD: 10'			
Yield: 140 g.p.m.			
Casing: No data			
Perfs.: No data			
Size & Type of Pump: Demming Centrifugal			
" " " " Motor: 5 h.p.			

Turn up Sheet of sheets

The Department of Ecology does NOT Warranty the Data and/or the Information on this Well Report.

MISLOCATED

5



WATER WELL REPORT

Original & 1st copy - Ecology, 2nd copy - owner, 3rd copy - driller

Construction/Decommission ("x" in circle)

Construction
 Decommission ORIGINAL INSTALLATION Notice
 of Intent Number 392457

PROPOSED USE: Domestic Industrial Municipal
 DeWater Irrigation Test Well Other

TYPE OF WORK: Owner's number of well (if more than one)
 New well Reconditioned Method: Dug Bored Driven
 Deepened Cable Rotary Jetted

DIMENSIONS: Diameter of well 6 inches, drilled 131 ft
 Depth of completed well 131 ft

CONSTRUCTION DETAILS
 Casing Welded 6 " Diam. from +1.5 ft. to 126 ft.
 Installed: Liner installed " Diam. from " ft. to " ft.
 Threaded " Diam. from " ft. to " ft.

Perforations: Yes No
 Type of perforator used _____
 SIZE of perfs _____ in by _____ in. and no. of perfs _____ from _____ ft. to _____ ft.

Screens: Yes No K-Pac Location 125'
 Manufacturer's Name Alloy Machine Works
 Type V-wire cont wrap - S.S. Model No. 304SS
 Diam. 6" tele Slot size 12 from 131 ft. to 126 ft.
 Diam. Slot size from ft. to ft.

Gravel/Filter packed: Yes No Size of gravel/sand _____
 Materials placed from _____ ft. to _____ ft.

Surface Seal: Yes No To what depth? 18 ft
 Material used in seal 3/8" bentonite chips
 Did any strata contain unusable water? Yes No
 Type of water? _____ Depth of strata _____
 Method of sealing strata off _____

PUMP: Manufacturer's Name Flint & Walling
 Type 10GPM SS H P 3/4

WATER LEVELS: Land-surface elevation above mean sea level _____ ft.
 Static level 8'5" ft below top of well Date 07/16/10
 Artesian pressure _____ lbs per square inch Date _____
 Artesian water is controlled by _____ (cap, valve, etc.)

WELL TESTS: Drawdown is amount water level is lowered below static level
 Was a pump test made? Yes No If yes, by whom? Bison
 Yield: 15 gal./min with 3'9" ft drawdown after 2.0 hrs.
 Yield: _____ gal./min with _____ ft drawdown after _____ hrs.
 Yield: _____ gal./min. with _____ ft. drawdown after _____ hrs.

Recovery data (time taken as zero when pump turned off) (water level measured from well top to water level)

Time	Water Level	Time	Water Level	Time	Water Level

 Date of test _____
 Baile test 20 gal./min. with 4'6" ft drawdown after 10 hrs
 Airtest _____ gal./min with stem set at _____ ft. for _____ hrs.
 Artesian flow _____ g.p.m. Date _____
 Temperature of water _____ Was a chemical analysis made? Yes No

CURRENT
 Notice of Intent No. W210491

Unique Ecology Well ID Tag No. BAC-440

Water Right Permit No. _____

Property Owner Name Jeanette Hubbard

Well Street Address 3906 84th Ave. Ct E

City Edgewood County Pierce

Location nw 1/4-1/4 ne 1/4 Sec 21 Twn 20 R 04 EWM or WWM circle one

Lat/Long (s, t, r) SEC 17 Lat Deg _____ Lat Min/Sec _____

Still REQUIRED) Long Deg _____ Long Min/Sec _____

Tax Parcel No. 0420175002

CONSTRUCTION OR DECOMMISSION PROCEDURE

Formation Describe by color, character, size of material and structure, and the kind and nature of the material in each stratum penetrated, with at least one entry for each change of information. (USE ADDITIONAL SHEETS IF NECESSARY)

MATERIAL	FROM	TO
brown silt	0	8
brown silty fine sand w/wood	8	13
grey fine silty sand	13	23
pea gravel w/course sand	23	25
brown silt w/trace peat	25	28
brown compacted silt bound sand/gravel w/wood	28	47
purple/gray clay w/sand lenses	47	49
grey clay	49	58
purple sandy silt	58	65
grey/brown silty fine sand	65	74
grey silty sand w/wood - trace H2O	74	82
grey fine sand - silty	82	87
brown silty sand	87	103
brown silty sand w/wood - H2O	103	107
grey silty sand	107	121
clean sand - H2O	121	129
sand/gravel - H2O	129	131
grey silt	131	

RECEIVED

AUG 18 2010

WA State Department of Ecology (SWRO)

Start Date 07/12/2010 Completed Date 07/14/2010

WELL CONSTRUCTION CERTIFICATION: I constructed and/or accept responsibility for construction of this well, and its compliance with all Washington well construction standards. Materials used and the information reported above are true to my best knowledge and belief.

Driller Engineer Trainee Name (Print) Driller - Darrell Feavel

Driller/Engineer/Trainee Signature _____

Driller or trainee License No 2398

Drilling Company Bison Well Drilling & Septic, LLC

Address PO Box 5142

City, State, Zip Spanaway, WA 98387

Contractor's

Registration No BISONWD945R9

Date 08/06/2010

Ecology is an Equal Opportunity Employer

IF TRAINEE,
 Driller's Licensed No. _____
 Driller's Signature _____

The Department of Ecology does NOT Warranty the Data and/or the Information on this Well Report.

IRRIGATION WELL
WATER WELL REPORT

Start Card No. 219724
UNIQUE WELL I.D. #

File Of: First Copy with Ecology
Second Copy - Owner's Copy
Third Copy - Driller's Copy

STATE OF WASHINGTON

Water Right Permit No.

(1) OWNER: Name JR Quall Construction Address 9709 104th St E

(2) LOCATION OF WELL: County Pierce SW 1/4 NW 1/4 Sec 22 T. 20 N. R. 4 E.

(2a) STREET ADDRESS OF WELL (or nearest address) Vally Ave Valley Townhouses

(3) PROPOSED USE: Domestic Irrigation DeWater Industrial Test Well Municipal Other

(10) WELL LOG or ABANDONMENT PROCEDURE DESCRIPTION
Formation: Describe by color, character, size of material and structure, and show thickness of aquifers and the kind and nature of the material in each stratum penetrated, with at least one entry for each change of information

MATERIAL	FROM	TO
Fine silty sand - silt layers	0	40
occasional gravel		
cleaner fine sand some gravel	40	55
Fine sandy silt	50	100
Fine silty sand some water	100	113

(4) TYPE OF WORK: Owner's number of well (if more than one) 1
Abandoned New well Deepened Reconditioned
Method: Dug Cable Rotary Bored Driven Jetted

(5) DIMENSIONS: Diameter of well 6" inches. Drilled 113 feet. Depth of completed well 52 ft.

(6) CONSTRUCTION DETAILS:
Casing installed: 6" Diam. from 12 ft. to 45 ft.
Welded Liner installed Threaded
Diam. from ft. to ft.
Diam. from ft. to ft.

Perforations: Yes No
Type of perforator used
SIZE of perforations in. by in.
 perforations from ft. to ft.
 perforations from ft. to ft.
 perforations from ft. to ft.

Screens: Yes No
Manufacturer's Name Johnson
Type 304 Model No.
Diam. 5" Slot size 25 from 46 ft. to 51 ft.
Diam. Slot size from ft. to ft.

Gravel packed: Yes No Size of gravel
Gravel placed from ft. to ft.

Surface seal: Yes No To what depth? 20 ft.
Material used in seal Bentonite +
Did any strata contain unuseable water? Yes No
Type of water? Depth of strata
Method of sealing strata off

(7) PUMP: Manufacturer's Name H.P.

(8) WATER LEVELS: Land surface elevation above mean sea level ft.
Static level Approx 5' ft. below top of well Date
Artesian pressure lbs. per square inch Date
Artesian water is controlled by (Cap, valve, etc.)

(9) WELL TESTS: Drawdown is amount water level is lowered below static level
Was a pump test made? Yes No If yes, by whom? Driller
Yield: Approx 25 gal./min. with From 4' drawdown after hrs.

Recovery data (time taken as zero when pump turned off) (water level measured from well top to water level)
Time Water Level Time Water Level Time Water Level
Date of test
Baller test gal./min. with ft. drawdown after hrs.
Airtest gal./min. with stem set at ft. for hrs.
Artesian flow g.p.m. Date By owner
Temperature of water Was a chemical analysis made? Yes No

Work Started 1st month 1993 completed 8-31 1993

WELL CONSTRUCTOR CERTIFICATION:
I constructed and/or accept responsibility for construction of this well, and its compliance with all Washington well construction standards. Materials used and the information reported above are true to my best knowledge and belief.
NAME Holt Testung Inc
(PERSON, FIRM, OR CORPORATION) (TYPE OR PRINT)
Address 10621 Todd Rd E
(Signed) Ruby Holt License No. 1099
Contractor's Registration No. HOLTTE-08705 Date 3-30 1994
(USE ADDITIONAL SHEETS IF NECESSARY)



DEWATERING WELL

8-17

The Department of Ecology does NOT Warranty the Data and/or the Information on this Well Report



WATER WELL REPORT

Original & 1st copy - Ecology, 2nd copy - owner, 3rd copy - driller

DEPARTMENT OF ECOLOGY
State of Washington

Construction/Decommission ("x" in circle)

- Construction
- Decommission ORIGINAL INSTALLATION

Notice of Intent Number _____

PROPOSED USE: Domestic Industrial Municipal
 DeWater Irrigation Test Well Other

TYPE OF WORK: Owner's number of well (if more than one) 10 wells
 New well Reconditioned Method: Dug Bored Driven
 Deepened Cable Rotary Jetted

DIMENSIONS: Diameter of well 1.5 inches, drilled 20 ft.
 Depth of completed well 20 ft.

CONSTRUCTION DETAILS

Casing Welded _____" Diam. from _____ ft. to _____ ft.
 Installed: Liner installed _____" Diam. from _____ ft. to _____ ft.
 Threaded _____" Diam. From _____ ft. to _____ ft.

Perforations: Yes No
 Type of perforator used _____
 SIZE of perfs _____ in. by _____ in. and no. of perfs _____ from _____ ft. to _____ ft.
 Screens: Yes No K-Pac Location _____
 Manufacturer's Name Western
 Type PVC Point Model No. _____
 Diam. 2 in Slot size 20 from 18 ft. to 20 ft.
 Diam. _____ Slot size _____ from _____ ft. to _____ ft.

Gravel/Filter packed: Yes No Size of gravel/sand 10/20
 Materials placed from 3 ft. to _____ ft.

Surface Seal: Yes No To what depth? 3 ft.
 Material used in seal Bentonite Chips
 Did any strata contain unusable water? Yes No
 Type of water? _____ Depth of strata _____
 Method of sealing strata off _____

PUMP: Manufacturer's Name _____
 Type: _____ H.P. _____

WATER LEVELS: Land-surface elevation above mean sea level _____ ft.
 Static level 4 ft. below top of well Date 7/25/2017
 Artesian pressure _____ lbs. per square inch Date _____
 Artesian water is controlled by _____ (cap, valve, etc.)

WELL TESTS: Drawdown is amount water level is lowered below static level
 Was a pump test made? Yes No If yes, by whom? _____
 Yield: _____ gal./min. with _____ ft. drawdown after _____ hrs.
 Yield: _____ gal./min. with _____ ft. drawdown after _____ hrs.
 Yield: _____ gal./min. with _____ ft. drawdown after _____ hrs.
 Recovery data (time taken as zero when pump turned off) (water level measured from well top to water level)

Time	Water Level	Time	Water Level	Time	Water Level
_____	_____	_____	_____	_____	_____
_____	_____	_____	_____	_____	_____
_____	_____	_____	_____	_____	_____

Date of test _____

Bailer test _____ gal./min. with _____ ft. drawdown after _____ hrs.
 Airtest _____ gal./min. with stem set at _____ ft. for _____ hrs.
 Artesian flow _____ g.p.m. Date _____
 Temperature of water _____ Was a chemical analysis made? Yes No

CURRENT

Notice of Intent No. DE02055

Unique Ecology Well ID Tag No. BKT976-BKT985

Water Right Permit No. _____

Property Owner Name Lattitude Development

Well Street Address 102 Todd Rd NE

City Puyallup County: Pierce

Location NW1/4-1/4 NW1/4 Sec 22 Twn 20N R 04E EWM
 (s, t, r Still REQUIRED) Or WWM

Lat/Long Lat Deg _____ Lat Min/Sec _____
 Long Deg _____ Long Min/Sec _____

Tax Parcel No. (Required) Road ROW

CONSTRUCTION OR DECOMMISSION PROCEDURE
 Formation: Describe by color, character, size of material and structure, and the kind and nature of the material in each stratum penetrated, with at least one entry for each change of information. (USE ADDITIONAL SHEETS IF NECESSARY.)

MATERIAL	FROM	TO
1.5 inch PVC		
Brown soil	0	3 ft
Gray silt	3	12 ft
Black sand	12	20 ft
3 ft surface seal w/ bentonite chips		
10 /20 colorado sand pack		
2 in x 2 ft PVC Screen		
20 slot screen		

RECEIVED
 AUG 29 2017
 WA State Department of Ecology (SWRO)

Start Date 07/25/2017 Completed Date 07/25/2017

WELL CONSTRUCTION CERTIFICATION: I constructed and/or accept responsibility for construction of this well, and its compliance with all Washington well construction standards. Materials used and the information reported above are true to my best knowledge and belief.

Driller Engineer Trainee Name (Print) Randy Harris
 Driller/Engineer/Trainee Signature _____
 Driller or trainee License No. 1374
 IF TRAINEE: Driller's License No: _____
 Driller's Signature: Randy Harris

Drilling Company Harris Water Well Drilling LLC
 Address 3980 E North Island Dr
 City, State, Zip Shelton, WA, 98584
 Contractor's Registration No. Harriww873J9 Date 07/25/2017



Tacoma-Pierce County
Health Department

Unique Well ID Number A C E 9 0 6
X Y Z 1 2 3

WELL TAGGING FORM

All shaded areas must be completed.

19

Date of Field Visit _____ By Matt + Kerry

ADDITIONAL WELL IDENTIFIERS

Department of Health System ID Number 56820 Source # SO 10

USGS Site Identification _____
Other _____

RECORD VERIFICATION

- Well Report available (please attach)
 Well Report not available
 Verification inconclusive

WELL OWNERSHIP, IF DIFFERENT FROM WELL REPORT

Name MOUNTAIN VIEW-EDGEWOOD WATER CO.
Street Address 11610 32nd St E
City EDGEWOOD State WA 98372-2099

LOCATION OF WELL, IF DIFFERENT FROM WELL REPORT

Well Address 4623 MERIDIAN E
City EDGEWOOD County PIERCE
T. 20 N. R. 04 E W.M. Sec. 15 SW 1/4 of the SW 1/4

Latitude 47 ° 12 ' 53.9 "

Longitude -122 ° 17 ' 31.09 "

- GPS (raw data)
 GPS (corrected)
 Topographic Map
 Survey
 Computer Generated
 Other _____

Elevation at land surface _____ feet/meters (circle one)

- Digital Altimeter
 Topographic Map
 Other _____

Additional information, if available:

Location marked on topographic map (please attach)

Location marked on air photo (please attach)

ACE906

19

Water right #

Priority Date

Circle One: Application Permit Certificate Claim Exempt

WELL CHARACTERISTICS

Physical Description of Well (size of casing, type of well, housing, etc.):

Location of Well Identification Tag:

Was supplemental tag needed for ease of identifying well?

NO YES

If yes, where was tag placed?

Scale 1:24,000 (1"=2,000')

Indicate the location of the well within the Section by drawing a dot at that point.

SECTION 15

TOWNSHIP 20

RANGE 04E

D	X	B	A
E	F	G	H
M	L	K	J
N	P	Q	R

COMMENTS: _____



Pierce County Assessor-Treasurer's Office



Parcel: R0420153014

Jan-08-2001, 08:44 AM

Name: MT VIEW EDGEWOOD WATER CO

ACE906

Site Address: 4623 MERIDIAN E

Mailing Address: 11610 32ND ST E , EDGEWOOD WA 98372

Use Code: 9100 IDENTIFIES THOSE PARCELS OF LAND THAT ARE UNDEVELOPED.REF MANUAL

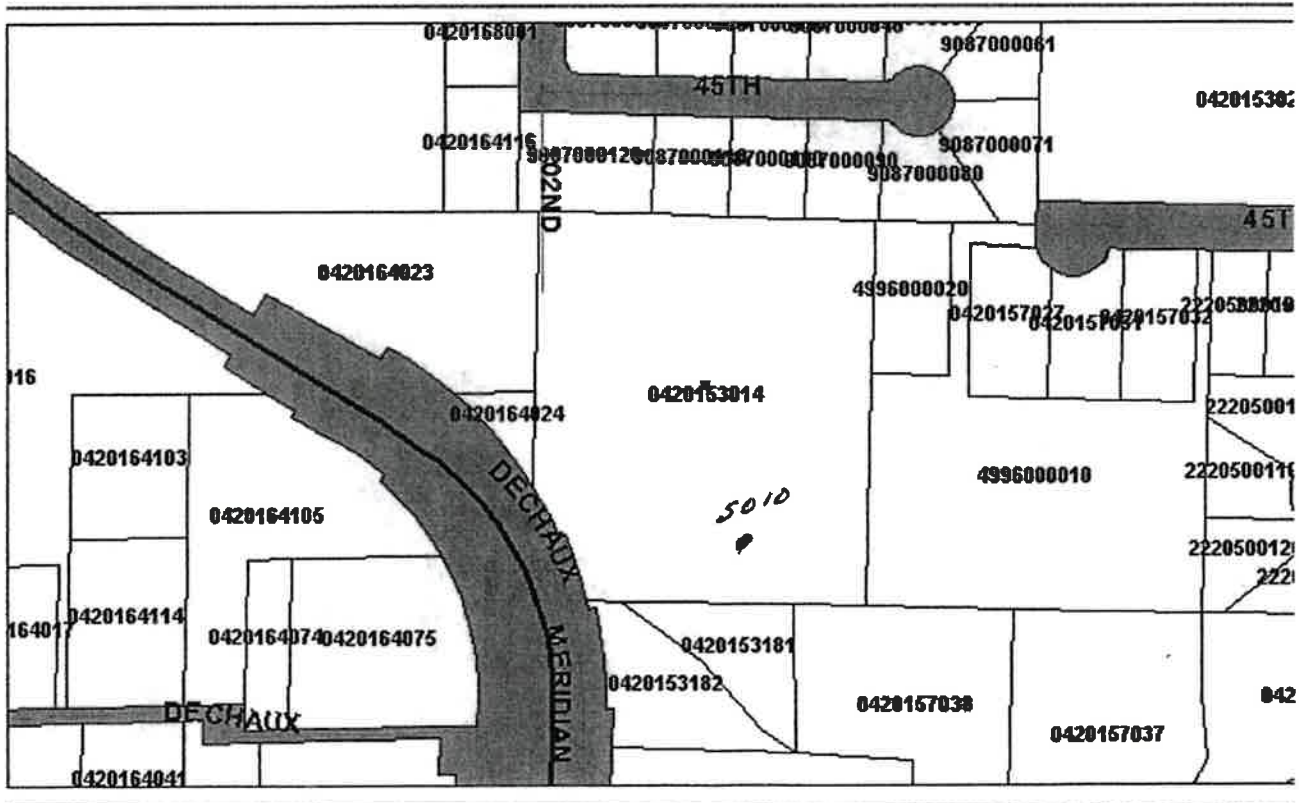
Mh Code:

Click One Tax & Assessment Land Characteristics Building Characteristics Parcel Map Recorded Data Back to S

Zoom Level: 5.0 Zoom

---North---

RTSQ: 04-20-15-3-3 School Dist: Puyallup



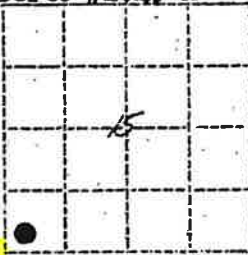
The Department of Ecology does NOT Warranty the Data and/or the Information on this Well Report

Pierce County Assessor-Treasurer 2401 South 35th St Room 142 Tacoma, Washington 98409 (253)798-6111 or Fax (253)798-3142

2.1

STATE OF WASHINGTON
DEPARTMENT OF CONSERVATION
AND DEVELOPMENT

WELL LOG No. Appl. #3303
Date June 22, 1953 Cert. #1749-A
Record by Fred B. Roberts
Source Driller's Record



Location: State of WASHINGTON
County Pierce
Area _____
Map _____

SW 1/4 SW 1/4 sec. 15 T. 20 N., R. 4 E.
Drilling Co. Robinson & Roberts, Groundwater Geologists

Address Tacoma, Washington
Method of Drilling _____ Date _____ 19____

Owner Mt. View-Edgewood Water Co.
Address 4408 N. Meridian St.; Puyallup, Washington

Land surface, datum _____ ft. above
_____ below

CORRE- LATION	MATERIAL	THICKNESS (feet)	DEPTH (feet)
------------------	----------	---------------------	-----------------

(Transcribe driller's terminology literally but paraphrase as necessary, in parentheses. If material water-bearing, so state and record static level if reported. Give depths in feet below land-surface datum unless otherwise indicated. Correlate with stratigraphic column, if feasible. Following log of materials, list all casings, perforations, screens, etc.)

	Sand & gravel, some clay	22	22
	Clay, yellow, soft some		
	sand & gravel	5	27
	Gravel up to 8" & sand, gray	29	56
	Gravel, sand & clay	3	59
	Gravel & sand, gray	11	70
	Gravel, coarse & sand, gray	12	82
	Hardpan, gray	11	93
Pump Test:			
	Dim: 9 1/4" x 12"		
	SWL: 2.8'		
	Dd: 6'		
	Yield: 580 g.p.m.		
	Casing: 12" diameter Standard drive casing,		
	+2 to 92'		
	Perf: 120 - Mills Knife, 1/2" x 2 1/2", 70' to 82'		

Turn up _____ Sheet _____ of _____ sheets

The Department of Ecology does NOT Warranty the Data and/or the Information on this Well Report.

File Original and First Copy with Department of Ecology
Second Copy - Owner's Copy
Third Copy - Driller's Copy

Dewatering WATER-WELL REPORT

STATE OF WASHINGTON

Water Right Permit No. _____

Start Card No. D-07889

UNIQUE WELL I.D. # _____

(1) OWNER: Name Roundup Co. Steve Salisbury Address PO Box 42121 Portland OR 97242

(2) LOCATION OF WELL: County Pierce NW 1/4 NE 1/4 Sec 21 T. 20N N.R. 4E W.M.

(2a) STREET ADDRESS OF WELL (or nearest address) 2200 North Meridian Puyallup wa 98371

(3) PROPOSED USE: Domestic Industrial Municipal
 Irrigation Test Well Other
 DeWater

(4) TYPE OF WORK: Owner's number of well (if more than one) 1-6
Abandoned New well Method: Dug Bored
Deepened Cable Driven
Reconditioned Rotary Jetted

(5) DIMENSIONS: Diameter of well 10 inches.
Drilled 40 feet. Depth of completed well 40 ft.

(6) CONSTRUCTION DETAILS:
Casing installed: 10 " Diam. from +1 ft. to 40 ft.
Welded " Diam. from _____ ft. to _____ ft.
Liner installed " Diam. from _____ ft. to _____ ft.
Threaded " Diam. from _____ ft. to _____ ft.

Perforations: Yes No
Type of perforator used mach. slot
SIZE of perforations .030 in. by 2 in.
_____ perforations from 40 ft. to 28 ft.
_____ perforations from _____ ft. to _____ ft.
_____ perforations from _____ ft. to _____ ft.

Screens: Yes No
Manufacturer's Name _____
Type _____ Model No. _____
Diam. _____ Slot size _____ from _____ ft. to _____ ft.
Diam. _____ Slot size _____ from _____ ft. to _____ ft.

Gravel packed: Yes No Size of gravel 3/8 Gravel
Gravel placed from _____ ft. to _____ ft.

Surface seal: Yes No To what depth? 3 ft.
Material used in seal Bentonite chips
Did any strata contain unusable water? Yes No
Type of water? _____ Depth of strata _____
Method of sealing strata off _____

(7) PUMP: Manufacturer's Name _____ H.P. _____
Type: _____

(8) WATER LEVELS: Land-surface elevation above mean sea level _____ ft.
Static level 16 ft. below top of well Date 7-18
Artesian pressure _____ lbs. per square inch Date _____
Artesian water is controlled by _____ (Cap, valve, etc.)

(9) WELL TESTS: Drawdown is amount water level is lowered below static level
Was a pump test made? Yes No If yes, by whom? _____
Yield: _____ gal./min. with _____ ft. drawdown after _____ hrs.

Recovery data (time taken as zero when pump turned off) (water level measured from well top to water level)
Time Water Level Time Water Level Time Water Level

Date of test _____
Beller test _____ gal./min. with _____ ft. drawdown after _____ hrs.
Airtest _____ gal./min. with stem set at _____ ft. for _____ hrs.
Artesian flow _____ g.p.m. Date _____
Temperature of water _____ Was a chemical analysis made? Yes No

(10) WELL LOG or ABANDONMENT PROCEDURE DESCRIPTION

Formation: Describe by color, character, size of material and structure, and show thickness of aquifers and the kind and nature of the material in each stratum penetrated, with at least one entry for each change of information.

MATERIAL	FROM	TO
Black Brown SILTY sand	0'	10'
Black sand Med to coarse	10'	30'
Grey clayey silty (wet)	30'	35'
Black Silty sand w/ gravel	35'	40'

RECEIVED

AUG 03 1994

DEPT. OF ECOLOGY

Work Started 7-18-94, 19. Completed 7-26, 19 94

WELL CONSTRUCTOR CERTIFICATION:

I constructed and/or accept responsibility for construction of this well, and its compliance with all Washington well construction standards. Materials used and the information reported above are true to my best knowledge and belief.

NAME Slead Construction Inc (PERSON, FIRM, OR CORPORATION) (TYPE OR PRINT) 531-2409

Address 2703 E 96th St Tacoma 98445

(Signed) [Signature] License No. 1852

Contractor's Registration No. Slead #3250 Date 8-1, 19 94

(USE ADDITIONAL SHEETS IF NECESSARY)

The Department of Ecology does NOT Warranty the Data and/or the Information on this Well Report.

DEWATERING WELL

24

D07889

File Original and First Copy with Department of Ecology
Second Copy - Owner's Copy
Third Copy - Driller's Copy

WATER WELL REPORT

STATE OF WASHINGTON

Start Card No.

UNIQUE WELL I.D. #

Water Right Permit No.

(1) OWNER: Name ROUNDUP CO. STEVE SALISBURY Address P.O. BOX 42121 PORTLAND OR 97242

(2) LOCATION OF WELL: County PIERCE NE 1/4 NE 1/4 Sec 21 T. 20N N. R. 4E W.M.

(2a) STREET ADDRESS OF WELL (or nearest address) 2200 NORTH MERIDIAN PUYALLUP, WA 98371

(3) PROPOSED USE: Domestic, Industrial, Municipal, Irrigation, Test Well, Other, DeWater (checked)

(4) TYPE OF WORK: Owner's number of well (if more than one) 10 thru 19
Abandoned, New well, Deepened, Reconditioned, Method: Dug, Cable, Rotary, Bored, Driven, Jetted

(5) DIMENSIONS: Diameter of well 10 inches. Drilled 40 feet. Depth of completed well 40 ft.

(6) CONSTRUCTION DETAILS: Casing installed: 10" diam. from 0 ft. to 40 ft.
Welded, Liner installed, Threaded, Perforations: Yes (checked) No

Type of perforator used MACHINE SLOTTED
SIZE of perforations .030 in. by .030 perforations from 10 ft. to 40 ft.

Screens: Yes No
Manufacturer's Name, Type, Diam., Slot size, from ft. to ft.

Gravel packed: Yes (checked) No
Size of gravel 3/8 minus
Gravel placed from 10 ft. to 40 ft.

Surface seal: Yes No To what depth?
Material used in seal, Did any strata contain unuseable water? Yes No
Type of water? Depth of strata, Method of sealing strata off

(7) PUMP: Manufacturer's Name, Type, H.P.

(8) WATER LEVELS: Land-surface elevation above mean sea level ft.
Static level ft. below top of well Date
Artesian pressure lbs. per square inch Date
Artesian water is controlled by (Cap, valve, etc.)

(9) WELL TESTS: Drawdown is amount water level is lowered below static level
Was a pump test made? Yes No If yes, by whom?
Yield: gal./min. with ft. drawdown after hrs.

Recovery data (time taken as zero when pump turned off) (water level measured from well top to water level)
Time Water Level Time Water Level

Date of test
Baller test gal./min. with ft. drawdown after hrs.
Airtest gal./min. with stem set at ft. for hrs.
Artesian flow g.p.m. Date
Temperature of water Was a chemical analysis made? Yes No

(10) WELL LOG & ABANDONMENT PROCEDURE DESCRIPTION

Formation: Describe by color, character, size of material and structure, and show thickness of aquifers and the kind and nature of the material in each stratum penetrated, with at least one entry for each change of information.

Table with columns MATERIAL, FROM, TO. Entries include BROWN SILTY SAND, BLACK SAND MED TO COURSE, gray clay silty wet, BLACK SILTY SAND W/ GRAVEL.

WELL CONSTRUCTOR CERTIFICATION:

I constructed and/or accept responsibility for construction of this well, and its compliance with all Washington well construction standards. Materials used and the information reported above are true to my best knowledge and belief.

NAME SLEAD'S CONSTRUCTION, INC
2703 EAST 96TH STREET
Address TACOMA, WA 98445
(Signed) Phil Reinstein License No. 2066

Contractor's Registration No. SLEADC*325K0 Date 9/20/94

(USE ADDITIONAL SHEETS IF NECESSARY)

The Department of Ecology does NOT Warranty the Data and/or the Information on this Well Report.

Out of SEARCH RADIUS

(1) OWNER: Name **YAGUCHI TED** Address **PO BOX 1088 PUYALLUP, WA 98371-**

(2) LOCATION OF WELL: County **PIERCE** - NE 1/4 SE 1/4 Sec 16 T 20 N., R 4E WM

(2a) STREET ADDRESS OF WELL (or nearest address) **4303 90TH AVE E**

(3) PROPOSED USE: **DOMESTIC**

(4) TYPE OF WORK: Owner's Number of well (If more than one) **NEW WELL** Method: **AIR ROTARY**

(5) DIMENSIONS: Diameter of well **6** inches
 Drilled **50** ft. Depth of completed well **50** ft.

(6) CONSTRUCTION DETAILS:
 Casing installed: **6** Dia. from **0** ft. to **44.2** ft.
WELDED Dia. from ft. to ft.
 Dia. from ft. to ft.

Perforations: **NO**
 Type of perforator used
 SIZE of perforations in. by in.
 perforations from ft. to ft.
 perforations from ft. to ft.
 perforations from ft. to ft.

Screens: **YES** Manufacturer's Name **JOHNSON WELL**
 Type Model No.
 Diam. **6** slot size **30** from **44.2** ft. to **50** ft.
 Diam. slot size from ft. to ft.

Gravel packed: **NO** Size of gravel
 Gravel placed from ft. to ft.

Surface seal: **YES** To what depth? **18** ft.
 Material used in seal **BENTONITE CLAY**
 Did any strata contain unusable water? **NO**
 Type of water? Depth of strata ft.
 Method of sealing strata off

(7) PUMP: Manufacturer's Name **RED JACKET** H.P. **1/2**
 Type **SUBMERSIBLE**

(8) WATER LEVELS: Land-surface elevation above mean sea level ... ft.
Static level 7 ft. below top of well Date **02/25/91**
 Artesian Pressure lbs. per square inch Date / /
 Artesian water controlled by

(9) WELL TESTS: Drawdown is amount water level is lowered below static level.
 Was a pump test made? **NO** If yes, by whom?
 Yield: gal./min with ft. drawdown after hrs.

Recovery data
 Time Water Level Time Water Level Time Water Level

Date of test / /
 Bailer test **20** gal/min. B ft. drawdown after **1** hrs.
 Air test gal/min. w/ stem set at ft. for hrs.
 Artesian flow g.p.m. Date
 Temperature of water Was a chemical analysis made? **NO**

(10) WELL LOG *MISLOCATED NE of SW*
 Formation: Describe by color, character, size of material and structure, and show thickness of aquifers and the kind and nature of the material in each stratum penetrated, with at least one entry for each change in formation.

MATERIAL	FROM	TO
GRAVEL AND TOPSOIL	0	1
TOPSOIL	1	3
SAND	3	7
BEEPAGE SAND CLAY	7	16
PACKED SAND WOOD	16	19
COMPACTED SAND AND SOME GRAVEL	19	36
SANDY CLAY	36	47
WATER SAND & GRAVEL	47	50

Work started **02/22/91** Completed **02/25/91**

WELL CONSTRUCTOR CERTIFICATION:
 I constructed and/or accept responsibility for construction of this well, and its compliance with all Washington well construction standards. Materials used and the information reported above are true to my best knowledge and belief.

NAME **RICHARDSON WELL DRILLING** (Type or print)
 (Person, firm, or corporation) (Type or print)
 ADDRESS **PO BOX 44427 TAC WA 98444**
 [SIGNED] *Rich J. Richardson* license No. **0284**
 Contractor's Registration No. **RICHAM#3210B** Date **03/14/91**

Wetland Report



WETLAND, STREAM, AND FISH AND WILDLIFE HABITAT ASSESSMENT

PSE TODD ROAD

APRIL 2023



WETLAND, STREAM, AND FISH AND WILDLIFE HABITAT ASSESSMENT

PSE TODD ROAD

APRIL 12, 2023

PROJECT LOCATION

325 AND 221 TODD ROAD NORTHWEST
PUYALLUP, WASHINGTON 98371

PREPARED FOR

TRAMMEL CROW

600 UNIVERSITY STREET, SUITE 2912
SEATTLE, WASHINGTON 98101

PREPARED BY

SOUNDVIEW CONSULTANTS LLC

2907 HARBORVIEW DRIVE
GIG HARBOR, WASHINGTON 98335
(253) 514-8952



Executive Summary

Soundview Consultants LLC (SVC) has been assisting Trammel Crow (Applicant) with a wetland, stream, and fish and wildlife habitat assessment for the proposed commercial development on a 5.92-acre property located at 325 and 221 Todd Road Northwest in the City of Puyallup, Washington. The property consists of two parcels located in the Southwest ¼ of Section 21, Township 20 North, Range 4 East, W.M. (Pierce County Tax Parcel Numbers 0420211002 and 0420211012).

SVC investigated the subject property for the presence of potentially regulated wetlands, waterbodies, and fish and wildlife habitat in the fall of 2016, the fall and winter of 2018, the fall of 2022, and winter of 2023. The site investigations identified one potentially-regulated wetland (Wetland A) on the western boundary of the subject property and extending north and south within the right-of-way (ROW) of 4th Street Northwest. Wetland A is considered a Category IV depressional wetland that is likely exempt from regulation by the City per Puyallup Municipal Code (PMC) 21.06.910(4) due to its low rating and small size (less than 10,000 square feet). No other potentially-regulated wetlands or fish and wildlife habitat were identified within 300 feet of the subject property.

The table below summarizes the critical areas and identifies the potential regulatory status by local, state, and federal agencies.

Waterbody Name	Size Onsite	Category ¹ / Type	Regulated Under PMC Chapter 21.06	Regulated Under RCW 90.48	Regulated Under Clean Water Act
Wetland A	~64 SF	IV	Not Likely	Likely	Likely

1. Current WSDOE and PMC 21.06.910 wetland definitions.

Table of Contents

Chapter 1. Introduction	1
Chapter 2. Project Plan	2
2.1 Project Location	2
Chapter 3. Methods	3
Chapter 4. Existing Conditions.....	4
4.1 Landscape Setting	4
4.2 Soils.....	4
4.3 Critical Area Inventories	5
4.4 Precipitation.....	6
Chapter 5. Results	8
5.1 Upland Characterization	8
5.2 Wetlands.....	8
5.3 Wildlife Habitat Areas	9
Chapter 6. Regulatory Considerations	11
6.1 Local Critical Area Requirements.....	11
6.2 State and Federal Requirements.....	11
Chapter 7. Closure	13
Chapter 8. References	14

Figures

Figure 1. Vicinity Map.....	2
Figure 2. Aerial View of the Subject Property.....	4

Tables

Table 1. Precipitation Summary ¹	6
Table 2. Wetland Summary	8
Table 3. Wetland A Summary.	9
Table 4. Wetland Buffer Summary.....	11

Appendices

Appendix A – Methods and Tools	
Appendix B – Background Information	
Appendix C – Existing Conditions Exhibit	
Appendix D – Data Forms	
Appendix E – Wetland Rating Forms	
Appendix F – Wetland Rating Maps	
Appendix G – Qualifications	

Chapter 1. Introduction

Soundview Consultants LLC (SVC) has been assisting Trammel Crow (Applicant) with a wetland, stream, and fish and wildlife habitat assessment for the proposed commercial development on a 5.92-acre site located at 325 and 221 Todd Road Northwest in the City of Puyallup, Washington. The subject property consists of two parcels situated in the Southwest $\frac{1}{4}$ of Section 21, Township 20 North, Range 4 East, W.M. (Pierce County Tax Parcel Numbers 0420211002 and 0420211012).

The purpose of the wetland, stream, and fish and wildlife habitat assessment is to identify the presence of potentially regulated wetlands, waterbodies, or other fish and wildlife habitat areas that may be found on or near the subject property.

This report provides conclusions, recommendations, and preliminary specifications regarding:

- Site description and area of assessment;
- Background research and identification of potentially-regulated critical areas within the vicinity of the proposed project;
- Identification and assessment of potentially-regulated wetlands and other aquatic features;
- Identification and assessment of potentially-regulated fish and wildlife habitat;
- Existing site map detailing identified critical areas and standard buffers and setbacks; and
- Supplemental information necessary for local regulatory review.

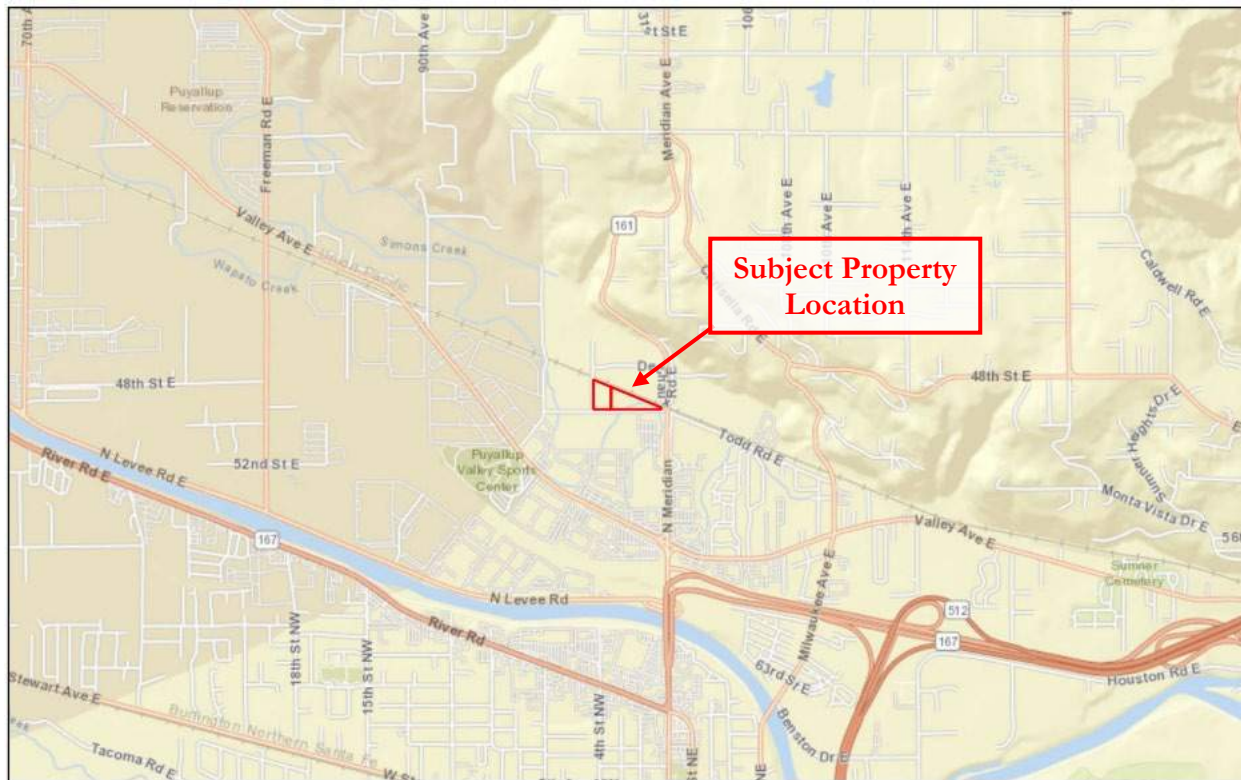
Chapter 2. Project Plan

2.1 Project Location

The subject property consists of a 5.92-acre site located at 325 and 221 Todd Road Northwest in the City of Puyallup, Washington (Figure 1). The subject site consists of two parcels situated in the Southwest ¼ of Section 21, Township 20 North, Range 4 East, W.M. (Pierce County Tax Parcel Numbers 0420211002 and 0420211012).

To access the subject site from Interstate-5 North from the Tacoma area, take the exit 137 for WA-99 North toward Fife/Middleton and merge onto 54th Avenue East. Continue onto Valley Avenue East for 3.1 miles. Take a left onto 7th Street Northwest and after 0.1 mile, turn right onto 23rd Avenue Northwest. Proceed for 0.3 mile and the subject property will be on the left.

Figure 1. Vicinity Map



12/13/2022, 12:45:40 PM
Subject Property

1:36,112
0 1,000 2,000 4,000 ft
0 337.5 675 1,350 m
County of King, Bureau of Land Management, Esri, HERE, Garmin, GeoTechnologies, Inc., NGA, USGS
Soundview Consultants

Chapter 3. Methods

SVC investigated and assessed any potentially-regulated wetlands, streams, and other fish and wildlife habitat conservation areas on or within 300 feet of the subject property in the in the fall of 2016, the fall and winter of 2018, and the fall of 2022. All determinations were made using observable vegetation, hydrology, and soils in conjunction with data from the U.S. Geological Survey (USGS) topographic maps, National Resource Conservation Service (NRCS) soil survey, U.S. Fish and Wildlife Service (USFWS) National Wetland Inventory (NWI) and Information for Planning and Consultation (IPaC) database, Washington State Department of Natural Resources (DNR) water typing system, Washington Department of Fish and Wildlife (WDFW) Priority Habitats and Species (PHS) and SalmonScape mapping tools, City of Puyallup and Pierce County Geographic Information Systems (GIS) data , and various orthophotographic resources. Appendix A contains further details for the methods and tools used to prepare this report.

Wetland boundaries were determined using the routine approach described in the U.S. Army Corps of Engineers (USACE) *Wetlands Delineation Manual* (Environmental Laboratory, 1987) and modified according to the guidelines established in the *Regional Supplement to the Corps of Engineers Wetland Delineation Manual: Western Mountains, Valleys, and Coast Region* (Version 2.0) (USACE, 2010) and *Field Indicators of Hydric Soils in the United States* (NRCS, 2018). Prior precipitation conditions and seasonal timing of site investigations were considered in evaluations for wetland hydrology indicators. Qualified wetland scientists marked boundaries of onsite wetlands with orange surveyor's flagging labeled alpha-numerically and tied to 3-foot lath or vegetation along the wetland boundary. Pink surveyor's flagging was labeled alpha-numerically and tied to 3-foot lath or vegetation at formal sampling locations to mark the points where detailed data was collected (DP-1 to DP-19). Additional tests pits were excavated at regular intervals inside and outside of the wetland boundaries to further confirm each delineation.

Wetlands were classified using the Cowardin (Cowardin, 1979) classification system. Following classification and assessment, wetlands were rated and categorized using the *Washington State Wetlands Rating System for Western Washington—Washington Department of Ecology, 2014, Publication No. 04-06-029*, per Puyallup Municipal Code (PMC) 21.06.910.

The fish and wildlife habitat assessment was conducted during the same site visits by qualified fish and wildlife biologists. The experienced biologists made visual and auditory observations using stationary and walking survey methods for both aquatic and upland habitats noting any special habitat features and direct and indirect signs of fish and wildlife activity (e.g. nesting, foraging, and migration/movement). Special attention was given to assessing the presence of fish and wildlife habitat conservation areas outlined under PMC 21.06.1010

Chapter 4. Existing Conditions

4.1 Landscape Setting

The subject property is located in an urban-commercial and rural-residential setting within the City of Puyallup (Figure 2). The site is currently developed with a gravel lot throughout the eastern portion of the site that has been utilized for equipment storage and parking, and the western portion of the site consists of undeveloped field. A single-family residence and associated infrastructure was demolished between 2018 and 2019. Topography on the subject property is generally flat, sloping gently down from east to the west with elevations ranging from approximately 48 feet above mean sea level (amsl) to 40 feet amsl. A topographic map is provided in Appendix B1. The subject property is located within Water Resource Inventory Area (WRIA) 10 – Puyallup-White.

Figure 2. Aerial View of the Subject Property



4.2 Soils

The NRCS Soil Survey of Pierce County, Washington identifies three soil series on the site: Sultan silt loam (42A), Puyallup Fine Sandy Loam (31A), and Pilchuck Fine Sand (29A). A soil map is provided in Appendix B2 (Zulauf, 1979).

Sultan silt loam (42A)

Sultan silt loam (42A) soil series are moderately well drained soils formed in recent alluvium on floodplains at the sea level to 120 feet, under deciduous and coniferous trees. This soil is on the bottom lands along the Puyallup and White Rivers at elevations ranging from near sea level to 100 feet. Slopes are less than 2 percent, and the surface is smooth. In a typical profile, the surface layer is a dark grayish brown (10YR 3/2) silt loam about 14 inches thick. The underlying material to a depth of 34 inches is a mottled, brown silt loam and dark yellowish brown (10YR 5/4) very fine sandy loam. To a depth of more than 60 inches, it is a mottled, dark gray fine sandy loam, gray silty clay loam, very dark grayish brown fine sand, and dark yellowish brown silt loam. The Sultan soil series is listed as non-hydric, however, as much as 8% of areas mapped as Sultan silt loam may contain hydric inclusions of Briscot and Puget soils (NRCS, N.d.).

Puyallup fine sandy loam (31A)

Puyallup fine sandy loam (31A) soil series has 0 to 3 percent slopes and are well drained soils formed in recent alluvium on the natural levees along the Puyallup River. Puyallup soils are usually found on floodplains and low-lying areas. In a typical profile, the surface layer is a very dark brown ashy fine sandy loam about 13 inches thick. The underlying material to a depth of 50 inches is a very dark grayish brown loamy fine sand and fine sand. Between depths of 50 and more than 68 inches, it is dark grayish brown fine sandy loam and fine sand. The Puyallup soil series is considered non-hydric (NRCS, N.d.).

Pilchuck fine sand (29A)

According to the survey, Pilchuck fine sand is excessively drained soil formed in major river valleys in mixed alluvium under hardwoods and conifers. In a typical profile, the surface layer is very dark brown fine sand about 7 inches thick. The underlying material to a depth of 36 inches is very dark brown fine sand, and very dark brown very gravelly sand to a depth of 60 inches or more. Pilchuck fine sand is listed as non-hydric on the Pierce County Hydric Soils List (NRCS, N.d.).

4.3 Critical Area Inventories

The DNR Stream Typing map (Appendix B3), WDFW PHS map (Appendix B4), and WDFW SalmonScape map (Appendix B5) erroneously identify a potential Type F stream, labelled as Wapato Creek, across the eastern portion of the subject property, extending off site to the south. The WDFW PHS map also identifies an offsite wetland associated with the stream southeast of the subject property. The City of Puyallup Stream and Wetland Inventory (Appendix B6), Pierce County Stream and Wetland Inventory (Appendix B7), and USFWS NWI map (Appendix B8) accurately identify Wapato Creek offsite, approximately 360 feet to the west of the subject property at its closest point. The City also maps an offsite wetland associated with Wapato Creek approximately 70 feet to the west of the subject property. No other wetlands or other waterbodies are documented on or within 300 feet of the subject property were identified during the background investigation.

WDFW SalmonScape map identifies documented coho and steelhead and a gradient accessible reach for chinook and pink salmon within the erroneously mapped Wapato Creek onsite. The WDFW PHS map also identified steelhead and coho presence within the erroneously mapped stream onsite. Additionally, waterfowl concentrations were erroneously mapped adjacent to the southeast corner of the subject property, which currently consists of parking lots and warehouses. WDFW PHS does identify western pond turtle (*Actinemys marmorata*) within the township, but not necessarily on or near

the site. According to the USFWS IPaC mapping database, marbled murrelet (*Brachyramphus marmoratus*), streaked horned lark (*Eremophila alpestris strigata*), yellow-billed cuckoo (*Coccyzus americanus*), bull trout (*Salvelinus confluentus*) and Taylor’s checkerspot butterfly (*Euphydryas editha*) have the potential to occur within 300 feet of the subject property. No other potential priority habitats or species are documented within 300 feet of the subject property.

4.4 Precipitation

Precipitation data was acquired from the National Oceanic and Atmospheric Administration (NOAA) weather station at Seattle-Tacoma International Airport in order to obtain percent of normal precipitation for the Puyallup area during and preceding the investigations. A summary of data collected is provided in Table 1.

Table 1. Precipitation Summary¹

Date	Day of	Day Before	1 Week Prior	2 Weeks Prior	30 Days Prior (Observed/Normal)	Year to Date (Observed/Normal) ²	Percent of Normal ³
9/20/2016	0.00	0.08	0.30	0.79	1.03/1.25	24.75/22.70	82/109
10/5/2016	0.17	0.13	0.22	0.25	1.05/1.70	25.00/23.82	62/105
2/14/2018	0.24	0.14	0.29	1.17	6.35/4.56	28.15/22.79	139/124
11/29/2022	1.05	1.07	2.60	2.60	5.20/6.45	6.78/10.01	81/68
1/5/2023	Trace	0.02	0.75	4.49	6.73/5.73 ⁴	14.92/16.90 ⁵	117/88

Notes:

1. Precipitation levels provided in inches. Data obtained from NOAA (<http://w2.weather.gov/climate/xmacis.php?wfo=sew>) for SeaTac International Airport.
2. Year-to-date precipitation is for the calendar year from January 1 to onsite dates for the 2016 investigations, and the water year from October 1 to the onsite dates for 2018, 2022, and 2023.
3. Percent of normal is shown for the last 30 days and water year to date.
4. Missing precipitation data from December 21, 2022, therefore precipitation level may be under-represented.
5. Missing precipitation data from November 25 and December 21, 2022, therefore precipitation level may be under-represented.

During the 2016 site visits, precipitation was approximately 82 and 62 percent of normal 30 days prior to the site inspections, and 109 and 105 percent of normal for the calendar year. This data suggests conditions may have been somewhat drier than normal for the past 30 days during the October 2016 site visit. However, given that October is the end of the dry season, the observed conditions are relatively normal.

During February 2018 site visit precipitation levels were approximately 139 percent of normal for the 30 days prior, and 124 percent of statistical normal for the 2017/2018 water year. This precipitation data suggests that above normal precipitation during the prior 30 days during the wet season may have caused some areas not normally wet to become saturated or inundated during the time of the recent site investigations compared to the drier conditions of the earlier site visits.

The precipitation during the November 2022 site visit was within the statistical normal for the prior 30 days (81 percent of normal) and was below the statistical normal for the water year (68 percent of normal). This suggests that hydrologic conditions were drier than normal during the November site. The precipitation during the January 2023 site visit was within the statistical normal for the prior 30

days (117 percent of normal) and the water year (88 percent of normal). Such conditions were considered in making professional wetland boundary determinations.

Chapter 5. Results

The site investigations identified one wetland (Wetland A) subject property. No other wetlands, waterbodies, or priority habitats or species were identified on or within 300 feet of the subject property. A map depicting existing conditions is included in Appendix C.

5.1 Upland Characterization

The subject property is partially developed with gravel lot in the eastern portion of the site, and undeveloped field in the western portion of the site. Vegetation in the agricultural field on the east side of the property are dominated by various grass and forb species typical to fields, including colonial bentgrass (*Agrostis capillaris*) and meadow foxtail (*Alopecurus pratensis*).

5.2 Wetlands

One wetland (Wetland A) was identified on the subject property. The identified onsite wetland contained indicators of hydric soils, wetland hydrology, and a predominance of hydrophytic vegetation according to current wetland delineation methodology. Wetland data forms are provided in Appendix D, wetland rating forms are provided in Appendix E, and wetland rating maps are provided in Appendix F. Table 2 summarizes the wetlands identified during the site investigations.

Table 2. Wetland Summary

Wetland	Predominant Wetland Classification / Rating			Wetland Size Onsite (SF)
	Cowardin ¹	HGM	City of Puyallup ²	
A	PEMBC	Depressional	IV	64


1. Cowardin et al. (1979); Federal Geographic Data Committee (2013); class based on vegetation: PEM = Palustrine Emergent. Modifiers for Water Regime: B = Seasonally Saturated, C = Seasonally Flooded.

2. Current WSDOE rating system per PMC 21.06.910

Wetland A

Wetland A is 64 square feet (0.001 acres) in size onsite and is located on the western edge of parcel - 1002, extending offsite along 4th Street Northwest (Decheaux Road). The wetland is approximately 1,394 square feet (0.032 acres) in total size. Hydrology for Wetland A is provided by surface sheet flow, direct precipitation, and a seasonally-high groundwater table. Wetland A appears to outlet to a non-wetland, roadside ditch along 4th Street Northwest to the west of the site under the road through a culvert. Wetland vegetation is dominated by soft rush (*Juncus effusus*), curly dock (*Rumex crispus*), creeping buttercup (*Ranunculus repens*), common velvetgrass (*Holcus lanatus*), and colonial bentgrass (*Agrostis capillaris*). Hydric soil indicator F3 (Depleted Matrix) was observed. The wetland was delineated based on the point of saturation and a transition to a hydrophytic plant community. The onsite buffer is degraded by actively managed agricultural fields. Wetland A is a Palustrine Emergent, Seasonally Saturated, Seasonally Flooded (PEMBC) wetland. Table 3 provides a summary of Wetland A.

Table 3. Wetland A Summary.

WETLAND A		
	Local Jurisdiction	City of Puyallup
	City of Puyallup Rating	IV
	Wetland Size (Onsite)	64 SF
	Cowardin Classification	PEMBC
	HGM Classification	Depressional
	Wetland Data Sheet(s)	DP-15
	Upland Data Sheet(s)	DP-14, DP-16, and DP-17
Wetland Functions Summary		
Water Quality (Scores 6 out of 9 points)	<ul style="list-style-type: none"> • Low site potential to trap sediments and pollutants and remove nitrogen due to an intermittently flowing outlet, less than 10% cover of persistent, ungrazed vegetation and less than 50% of the wetland seasonally ponds. • Moderate landscape potential to receive sediment and pollutants due to the surrounding land uses that produce pollutants. • High societal value for water quality functions due to the wetland discharging directly into degraded waters and 303(d) listed waterway within the sub-basin. 	
Hydrologic (Scores 5 out of 9 points)	<ul style="list-style-type: none"> • Low site potential to reduce flooding and erosion due to an intermittently flowing outlet, the moderate storage depth during wet periods and the small size of the wetland relative to the contributing basin. • Moderate landscape potential to provide flood protection due to the adjacent land uses that produce run-off. • Moderate societal value for hydrologic functions due to surface flooding within a downgradient sub-basin 	
Habitat (Scores 3 out of 9 points)	<ul style="list-style-type: none"> • Low site potential to provide diverse and complex habitat as the wetland consists entirely of one plant community, two hydroperiods, moderate species richness, no habitat interspersion, and one special habitat feature. • Low landscape potential to support habitat use due to the lack of accessible and undisturbed habitat and the high intensity land uses surrounding the property. • Low societal value for habitat functions due to the lack of nearby WDFW Priority Habitats 	

5.3 Wildlife Habitat Areas

Per PMC 21.06.1010, fish and wildlife habitat conservation areas are those areas identified as being of critical importance to the maintenance of fish, wildlife, or plant species. This includes streams and their associated riparian habitat areas, non-riparian habitat areas that support or have a primary association with state or federally listed species, state priority habitats and areas associated with a state priority species, and habitats and species of local importance, including habitat corridors, habitat blocks, and open spaces. No streams were identified on or within 300 feet of the subject property, therefore the site does not provide suitable fish habitat onsite.

According to the USFWS IPaC mapping database, marbled murrelet (*Brachyramphus marmoratus*), streaked horned lark (*Eremophila alpestris strigata*), yellow-billed cuckoo (*Coccyzus americanus*), bull trout (*Salvelinus confluentus*) and Taylor's checkerspot butterfly (*Euphydryas editha*) have the potential to occur within 300 feet of the subject property.

Marbled murrelet that occur in the state of Washington are year-round residents on coastal waters and primarily feed in waters within 500 feet of the shore out to 1.2 miles from shore at depths of less than one hundred feet. Potential suitable nesting habitat typically consists of tree stands 5 or more acres in size composed of 60% or more conifer cover with minimum 15-inch diameter at breast height (DBH). The subject property is not suitable for marbled murrelet nesting habitat due to a lack of significant tree stands, and its distance (approximately 7 miles) from the nearest marine shoreline.

Streaked horned lark are found primarily in prairie habitat or unvegetated to sparsely vegetated open habitats (Pearson & Anderson, 2015), in dune habitats along the coast of Washington; in prairies of western Washington and western Oregon; and on the sandy beaches and islands along the Columbia and Willamette Rivers (USFWS, 2019). Studies conducted by the USFWS indicate that sites used by larks are generally found in open (i.e., flat, treeless) landscapes 300 acres or more in size such as airports (USFWS, 2013). The open field areas on the subject property are not large enough to support streaked horn lark habitat. In addition, the field areas are regularly maintained for agricultural uses that limit the potential for streaked horned lark utilizing the subject property.

Yellow-billed cuckoo habitat consists of low to mid-level riparian forests dominated by cottonwoods and willows. Suitable habitat is approximately 100 to 198 acres and wider than 200 meters; marginal habitat is approximately 20 to 100 acres and 100 to 200 meters wide; and unsuitable habitat is smaller than approximately 37 acres and less than 100 meters wide (Wiles & Kalasz, 2017). The subject site is does not provide the required low to mid-level riparian forests for suitable yellow billed cuckoo habitat.

Bull trout require cold water temperatures, clean stream substrates, complex streams, and connectivity to river, lakes, and ocean habitats. There are no streams on or within 300 feet of the subject property, thus eliminating the potential for bull trout and their habitat.

Taylor's checkerspot butterfly is primarily found in open prairie and grass/oak woodland habitat (Potter, 2016). Taylor's checkerspot habitat is dependent upon food sources for larvae and nectar sources for adults. Despite the presence of open grass areas onsite, these areas are regularly maintained and modified due to agricultural activities, and likely do not provide suitable habitat or food sources for larvae or adults.

In addition, the WDFW PHS map identified winter steelhead (*Oncorhynchus mykiss*) and coho (*Oncorhynchus kisutch*) presence within the stream erroneously mapped onsite. No stream was identified on or within 300 feet of the subject property, thus eliminating the potential for steelhead, coho and their habitat. Waterfowl concentrations that are associated with wetlands and agricultural areas in Pierce County were mapped adjacent to the southeast corner of subject property. The priority area mapped is a distribution center parking lot and does not support waterfowl concentrations.

Chapter 6. Regulatory Considerations

The site investigations identified one wetland (Wetland A) on the subject property. No other wetlands, waterbodies, or priority habitats or species were identified on or within 300 feet of the subject property.

6.1 Local Critical Area Requirements

PMC 21.06.910 has adopted the current wetland rating system for western Washington (Hruby, 2014). Category IV wetlands have the lowest level of functions and are often heavily disturbed. Wetland A is classified as a Category IV wetland. PMC 21.06.930(2) establishes wetland buffers based on wetland rating, wetland habitat score, and the intensity of land uses proposed on the development site. Per PMC 21.06.930(2)(e), Category IV wetlands are subject to a standard 50-foot buffer for proposed high intensity land use. However, per PMC 21.06.910(4), Category IV wetlands under 10,000 square feet are not subject to the regulations identified in PMC 21.06. As a result, Wetland A is likely exempt from regulation by the City, and no buffer or mitigation is required by the City for wetland impacts.

Table 4. Wetland Buffer Summary.

Wetland	Category	Habitat Score	Proposed Land Use Intensity	Standard Buffer Width
A	IV	3	High	N/A

6.2 State and Federal Requirements

On January 18, 2023, USACE and EPA published a revised definition of “Waters of the United States.” The revised rule becomes effective on March 20, 2023. Under the 2023 revised rule, Waters of the United States is described as follows (USACE and EPA, 2023):

(a) Waters of the United States means:

(1) Waters which are: (i) Currently used, or were used in the past, or may be susceptible to use in interstate or foreign commerce, including all waters which are subject to the ebb and flow of the tide; (ii) The territorial seas; or (iii) Interstate waters, including interstate wetlands;

(2) Impoundments of waters otherwise defined as waters of the United States under this definition, other than impoundments of waters identified under paragraph (a)(5) of this section;

(3) Tributaries of waters identified in paragraph (a)(1) or (2) of this section: (i) That are relatively permanent, standing or continuously flowing bodies of water; or (ii) That either alone or in combination with similarly situated waters in the region, significantly affect the chemical, physical, or biological integrity of waters identified in paragraph (a)(1) of this section;

(4) Wetlands adjacent to the following waters: (i) Waters identified in paragraph (a)(1) of this section; or (ii) Relatively permanent, standing or continuously flowing bodies of water identified in paragraph (a)(2) or (a)(3)(i) of this section and with a continuous surface connection to those waters; or (iii) Waters identified in paragraph (a)(2) or (3) of this section

when the wetlands either alone or in combination with similarly situated waters in the region, significantly affect the chemical, physical, or biological integrity of waters identified in paragraph (a)(1) of this section;

(5) Intrastate lakes and ponds, streams, or wetlands not identified in paragraphs (a)(1) through (4) of this section: (i) That are relatively permanent, standing or continuously flowing bodies of water with a continuous surface connection to the waters identified in paragraph (a)(1) or (a)(3)(i) of this section; or (ii) That either alone or in combination with similarly situated waters in the region, significantly affect the chemical, physical, or biological integrity of waters identified in paragraph (a)(1) of this section.

Wetlands A and B are assumed to be regulated as WOTUS under the CWA.

Wetland A is presumed to be federally regulated through a “significant nexus” to another WOTUS, such as Wapato Creek to the west. Wetland A is also considered a natural water that is likely regulated by the WSDOE through the Revised Code of Washington (RCW) 90.48.

Chapter 7. Closure

The findings and conclusions documented in this report have been prepared for specific application to the PSE Todd Road site. They have been developed in a manner consistent with that level of care and skill normally exercised by members of the environmental science profession currently practicing under similar conditions in the area. Our work was also performed in accordance with the terms and conditions set forth in our proposal. The conclusions and recommendations presented in this report are professional opinions based on an interpretation of information currently available to us and are made within the operation scope, budget, and schedule of this project. No warranty, expressed or implied, is made. In addition, changes in government codes, regulations, or laws may occur. Because of such changes, our observations and conclusions applicable to this project may need to be revised wholly or in part.

The critical area determinations by Soundview Consultants LLC are based on conditions present at the time of the site inspection and considered preliminary until the presence or absence and location of critical areas are validated by the jurisdictional agencies. Validation of the critical area determinations by the regulating agencies provides a certification, usually written, that the critical area boundaries or lack thereof verified are the boundaries that will be regulated by the agencies until a specific date or until the regulations are modified. Only the regulating agencies can provide this certification.

Since critical areas are dynamic communities affected by both natural and human activities, changes in critical area determinations and/or boundaries may be expected; therefore, critical area determinations cannot remain valid for an indefinite period of time. Local agencies typically recognize the validity of critical area determinations for a period of 5 years after completion of a wetland delineation and fish and wildlife habitat assessment report. Development activities on a site 5 years after the completion of this report may require revision of the critical area determinations and/or delineations. In addition, changes in government codes, regulations, or laws may occur. Because of such changes, our observations and conclusions applicable to this site may need to be revised wholly or in part.

Chapter 8. References

- Brinson, M. M. 1993. *A hydrogeomorphic classification for wetlands*, Technical Report WRP-DE-4. U.S. Army Engineer Waterways Experiment Station. Vicksburg, Mississippi.
- Cowardin, L.M. V. Carter, F. Golet, and E.T. LaRoe. 1979. *Classification of Wetlands and Deepwater Habitats of the United States*. U.S. Fish and Wildlife Service. Washington D.C.
- Environmental Laboratory. 1987. *Corps of Engineers Wetlands Delineation Manual*. Technical Report Y-87-1, US Army Engineer Waterways Experiment Station, Vicksburg, Mississippi.
- Federal Geographic Data Committee. 2013. *Classification of wetlands and deepwater habitats of the United States*. FGDC-STD-004-2013. Second Edition. Wetlands Subcommittee, Federal Geographic Data Committee and U.S. Fish and Wildlife Service, Washington, DC.
- Granger, T., T. Hruby, A. McMillan, D. Peters, J. Rubey, D. Sheldon, S. Stanley, and E. Stockdale. 2005. *Wetlands in Washington State - Volume 2: Guidance for Protecting and Managing Wetlands*. Washington State Department of Ecology. Publication #05-06-008. Olympia, Washington. April 2005.
- Hitchcock, C.L. & A. Cronquist, Ed. by D. Giblin, B. Ledger, P. Zika, and R. Olmstead. 2018. *Flora of the Pacific Northwest, 2nd Edition*. U.W. Press and Burke Museum. Seattle, Washington.
- Hruby, T. 2014. *Washington State Wetland Rating System for Western Washington: 2014 Update*. (Publication #14-06-029). Olympia, WA: Washington Department of Ecology.
- Munsell® Color, 2000. *Munsell® Soil Color Charts*. New Windsor, New York.
- Natural Resources Conservation Services (NRCS). 2022. Soil Data Access Hydric Soils List (Soil Data Access Live). Date Accessed: November 16, 2022. Website: https://www.nrcs.usda.gov/Internet/FSE_DOCUMENTS/nrcseprd1316620.html.
- NRCS. 2018. *Field Indicators of Hydric Soils in the United States, Version 8.2*. L.M. Vasilas, G.W. Hurt, and J.F. Berkowitz (eds.). USDA, NRCS, in cooperation with the National Technical Committee for Hydric Soils.
- Puyallup Municipal Code (PMC). 2022. *Chapter 21.06 – Critical Areas*. Current through September 27, 2022. Website: <https://www.codepublishing.com/WA/Puyallup>.
- USACE. 2010. *Regional Supplement to the Corps of Engineers Wetland Delineation Manual: Western Mountains, Valleys, and Coast Region (Version 2.0)*, ed. J. S. Wakeley, R. W. Lichvar, and C. V. Noble. ERDC/EL TR-10-3. Vicksburg, MS: U.S. Army Engineer Research and Development Center. Vicksburg, Mississippi.
- USACE. 2020. *National Wetland Plant List, version 3.5*. <http://wetland-plants.usace.army.mil/>
- USACE and Environmental Protection Agency (EPA). 2023. “Revised Definition of Waters of the United States.” 88 FR 3004. January 18, 2023.

United States Fish and Wildlife (USFWS). Nd. Information for Planning and Consultation. Website: <https://ipac.ecosphere.fws.gov/>. Accessed December 2022.

Wiles, G.J. and K.S. Kalasz, 2017. *Washington State Status Report for the yellow-billed cuckoo*. Washington Department of Fish and Wildlife. May 2017.

Zulauf, A.S. 1979. *Soil Survey of Pierce County Area, Washington*. Natural Resource Conservation Service. Washington D.C

Appendix A – Methods and Tools

Table A1. Methods and tools used to prepare the report.

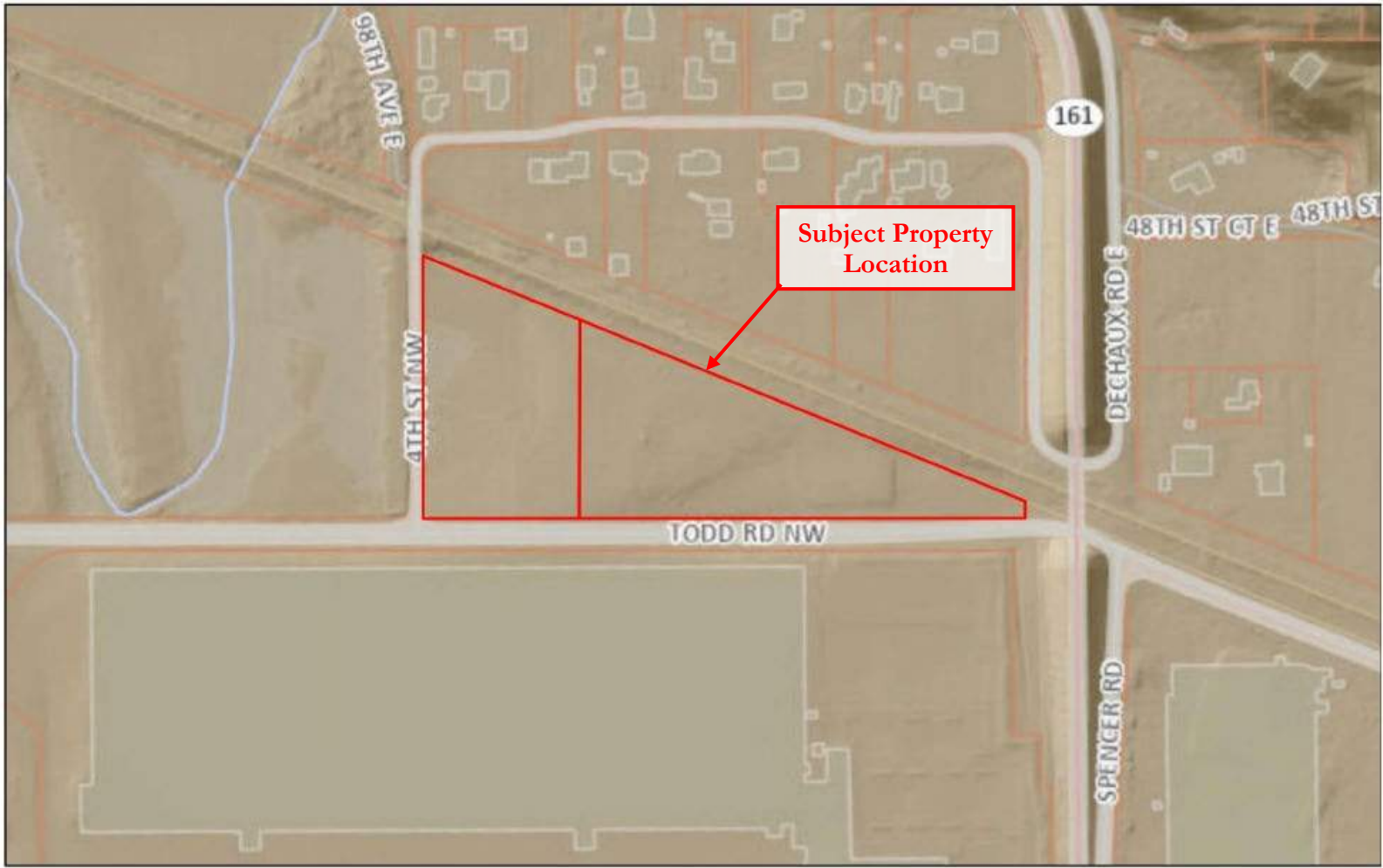
Parameter	Method or Tool	Website	Reference
Wetland Delineation	USACE 1987 Wetland Delineation Manual	http://el.erdc.usace.army.mil/elpubs/pdf/wlman87.pdf	Environmental Laboratory. 1987. Corps of Engineers Wetlands Delineation Manual. Technical Report Y-87-1, US Army Engineer Waterways Experiment Station, Vicksburg, Mississippi.
	Western Mountains, Valleys, and Coast Region Regional Supplement	http://www.usace.army.mil/Portals/2/docs/civilworks/regulatory/reg_supp/west_mt_final_supp.pdf	U.S. Army Corps of Engineers. 2010. <i>Regional Supplement to the Corps of Engineers Wetland Delineation Manual: Western Mountains, Valleys, and Coast Region (Version 2.0)</i> , ed. J. S. Wakeley, R. W. Lichvar, and C. V. Noble. ERDC/EL TR-10-3. Vicksburg, MS: U.S. Army Engineer Research and Development Center.
Wetland Classification	USFWS / Cowardin Classification System	http://www.fws.gov/wetlands/Documents/Classification-of-Wetlands-and-Deepwater-Habitats-of-the-United-States.pdf https://www.fgdc.gov/standards/projects/wetlands/nvcs-2013	Cowardin, L. M., V. Carter, F. C. Golet, E. T. LaRoe. 1979. Classification of wetlands and deepwater habitats of the United States. Government Printing Office, Washington, D.C. Federal Geographic Data Committee. 2013. Classification of Wetlands and Deepwater Habitats of the United States. FGDC-STD-004-2013. Second Edition. Wetlands Subcommittee, Federal Geographic Data Committee and U.S. Fish and Wildlife Service, Washington, DC.
	Hydrogeomorphic Classification (HGM) System	http://el.erdc.usace.army.mil/wetlands/pdfs/wrpd4.pdf	Brinson, M. M. (1993). “A hydrogeomorphic classification for wetlands,” Technical Report WRP-DE-4, U.S. Army Engineer Waterways Experiment Station, Vicksburg, MS.
	Washington State Wetland Rating System	http://www.ecy.wa.gov/biblio/0406025.html	Hruby, T. 2014. Washington State wetland rating system for western Washington –Revised. Publication # 04-06-025.
Wetland Indicator Status	2020 National Wetland Plant List	http://wetland-plants.usace.army.mil/	Website.
Plant Names	USDA Plant Database	http://plants.usda.gov/	Website.
	Flora of the Pacific Northwest	http://www.pnwherberia.org/florapnw.php	Hitchcock, C.L. & A. Cronquist, Ed. by D. Giblin, B. Ledger, P. Zika, and R. Olmstead. 2018. Flora of the Pacific Northwest, 2nd Edition. U.W. Press and Burke Museum. Seattle, Washington.
Soils Data	NRCS Soil Survey	http://websoilsurvey.nrcs.usda.gov/app/	Website GIS data based upon: Zulauf, A.S. 1979. Soil Survey of Pierce County Area, Washington. Natural Resource Conservation Service. Washington D.C
	Washington State Hydric Soils List	http://www.wa.nrcs.usda.gov/technical/soils/hydric_lists/hydrosoil-wa-653.pdf	Natural Resources Conservation Service. 1983. Hydric Soils List: Pierce County, Washington. U.S. Department of Agriculture. Washington D.C.
	Soil Color Charts		Munsell® Color. 2000. Munsell® Soil Color Charts. New Windsor, New York.
	Field Indicators of Hydric Soils	https://www.nrcs.usda.gov/Internet/FSE_DOCUMENTS/nrcs142p2_053171.pdf	NRCS. 2018. <i>Field Indicators of Hydric Soils in the United States, Version 8.2.</i> L.M. Vasialas, G.W. Hurt, and C.V. Noble (eds.). USDA, NRCS, in cooperation with the National Technical Committee for Hydric Soils.
	Washington Natural Heritage Program	http://data-wadnr.opendata.arcgis.com/data	Washington Natural Heritage Program (Data published 07/19/17). Endangered, threatened, and sensitive plants of Washington. Washington State

Parameter	Method or Tool	Website	Reference
Threatened and Endangered Species		asets/wnhp-current-element-occurrences	Department of Natural Resources, Washington Natural Heritage Program, Olympia, WA
	Washington Priority Habitats and Species	http://wdfw.wa.gov/hab/phspage.htm	Priority Habitats and Species (PHS) Program Map of priority habitats and species in project vicinity. Washington Department of Fish and Wildlife.
Species of Local Importance	WDFW GIS Data	http://wdfw.wa.gov/mapping/salmonscape/	Website
Report Preparation	Puyallup Municipal Code (PMC)	https://www.codepublishing.com/WA/Puyallup	PMC Chapter 21.06 – Critical Areas.


Appendix B – Background Information

This Appendix includes a Pierce Contours Map (B1); NRCS Soil Survey Map (B2); DNR Stream Typing Map (B3); WDFW PHS Map (B4); WDFW SalmonScape Map (B5); Puyallup Stream and Wetland Inventory (B6); Pierce County Stream and Wetland Inventory (B7); and USFWS NWI Map (B8).

Appendix B1. Pierce County Contours Map

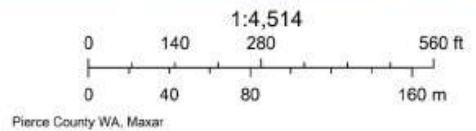


12/15/2022, 10:47:45 AM

 Subject Property

Pierce County

FiveByFive



Soundview Consultants

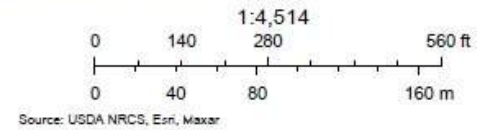
Appendix B2. NRCS Soil Survey Map



9/20/2022, 4:00:43 PM

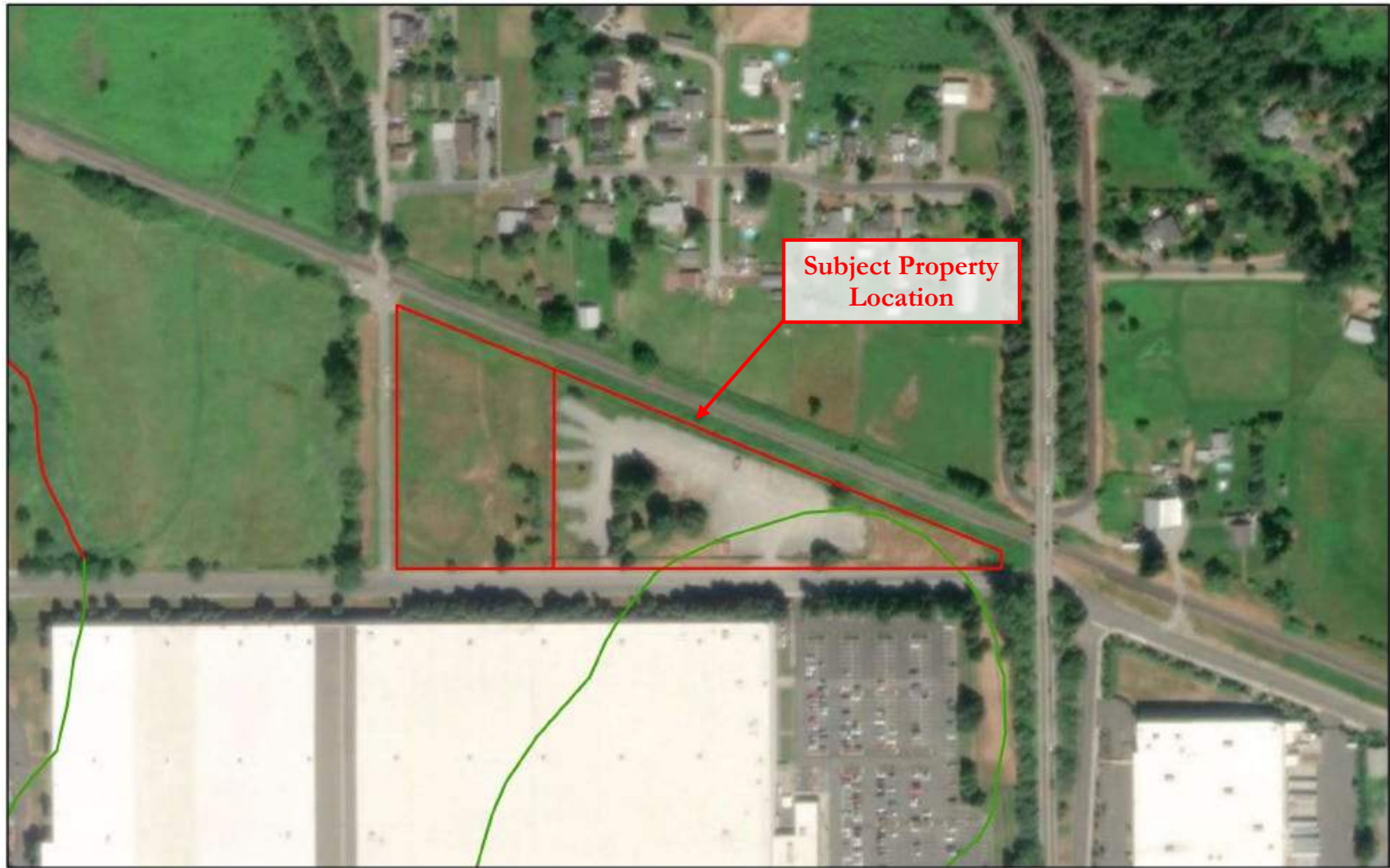
- Pierce - Parcels _Query result
- USA Soils Map Units

- 42A: Sultan silt loam
- 31A: Puyallup fine sandy loam
- 29A: Pilchuck fine sand





Soundview Consultants

Appendix B3. DNR Stream Typing Map



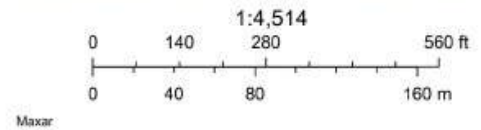
12/13/2022, 2:18:32 PM

 Subject Property

 Type N, Np, Ns

DNR - Stream Typing - Watercourses (DNR)

 Type F



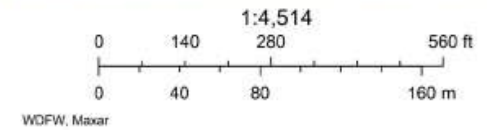
Soundview Consultants

Appendix B4. WDFW PHS Map



12/13/2022, 2:22:15 PM

- PHS Public Lines □ Masked □ QTR-TWP
- PHS Public Polygon Outlines PHS Public Polygons □ Subject Property
- AS MAPPED □ AS MAPPED



Soundview Consultants



Priority Habitats and Species on the Web

Occurrence Name	Federal Status	State Status	Sensitive Location
Winter Steelhead	N/A	N/A	No
Coho	N/A	N/A	No
Wetlands	N/A	N/A	No
Waterfowl Concentrations	N/A	N/A	No
Western Pond Turtle	N/A	Endangered	Yes

Winter Steelhead	
Scientific Name	<i>Oncorhynchus mykiss</i>
Priority Area	Occurrence/Migration
Site Name	Simons Creek
Accuracy	NA
Notes	LLID: 1223168472246, Fish Name: Steelhead Trout, Run Time: Winter, Life History: Anadromous
Source Record	41179
Source Dataset	SWIFD
Federal Status	N/A
State Status	N/A
PHS Listing Status	PHS Listed Occurrence
Sensitive	N
SGCN	N
Display Resolution	AS MAPPED
More Info	http://wdfw.wa.gov/wlm/diversty/soc/soc.htm
Geometry Type	Lines

Coho	
Scientific Name	<i>Oncorhynchus kisutch</i>
Priority Area	Occurrence/Migration
Site Name	Simons Creek
Accuracy	NA
Notes	LLID: 1223168472246, Fish Name: Coho Salmon, Run Time: Unknown or not Applicable, Life History: Anadromous
Source Record	41177
Source Dataset	SWIFD
Federal Status	N/A
State Status	N/A
PHS Listing Status	PHS Listed Occurrence
Sensitive	N
SGCN	N
Display Resolution	AS MAPPED
More Info	http://wdfw.wa.gov/wlm/diversty/soc/soc.htm
Geometry Type	Lines

Wetlands	
Priority Area	Aquatic Habitat
Site Name	COMMENCEMENT BAY TRIBUTARY WETLANDS
Accuracy	1/4 mile (Quarter Section)
Notes	VARIOUS WETLANDS ASSOCIATED WITH SMALL COMMENCEMENT BAY OF SOUTH PUGET SOUND TRIBUTARIES INCLUDING HYLEBOS AND WAPATO CREEK DRAINAGES.
Source Record	902561
Source Dataset	PHSREGION
Source Name	NAUER, DON WDW
Source Entity	WA Dept. of Fish and Wildlife
Federal Status	N/A
State Status	N/A
PHS Listing Status	PHS Listed Occurrence
Sensitive	N
SGCN	N
Display Resolution	AS MAPPED
ManagementRecommendations	http://www.ecy.wa.gov/programs/sea/wetlands/bas/index.html
Geometry Type	Polygons

Waterfowl Concentrations	
Priority Area	Regular Concentration
Site Name	PIERCE COUNTY - FARM
Accuracy	1/4 mile (Quarter Section)
Notes	SMALL WATERFOWL CONCENTRATION AREAS, AGRICULTURAL.
Source Record	902563
Source Dataset	PHSREGION
Source Name	NAUER, DON WDW
Source Entity	WA Dept. of Fish and Wildlife
Federal Status	N/A
State Status	N/A
PHS Listing Status	PHS LISTED OCCURRENCE
Sensitive	N
SGCN	N
Display Resolution	AS MAPPED
ManagementRecommendations	http://wdfw.wa.gov/publications/pub.php?id=00026
Geometry Type	Polygons

Western Pond Turtle	
Scientific Name	<i>Actinemys marmorata</i>
Notes	This polygon mask represents one or more records of the above species or habitat occurrence. Contact PHS Data Release (360-902-2543) for obtaining information about masked sensitive species and habitats.
State Status	Endangered
PHS Listing Status	PHS Listed Occurrence
Sensitive	Y
SGCN	Y
Display Resolution	QTR-TWP
ManagementRecommendations	http://wdfw.wa.gov/publications/pub.php?id=00025

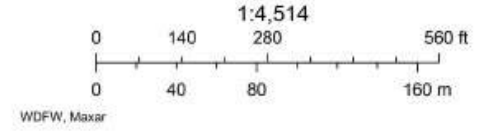
DISCLAIMER. This report includes information that the Washington Department of Fish and Wildlife (WDFW) maintains in a central computer database. It is not an attempt to provide you with an official agency response as to the impacts of your project on fish and wildlife. This information only documents the location of fish and wildlife resources to the best of our knowledge. It is not a complete inventory and it is important to note that fish and wildlife resources may occur in areas not currently known to WDFW biologists, or in areas for which comprehensive surveys have not been conducted. Site specific surveys are frequently necessary to rule out the presence of priority resources. Locations of fish and wildlife resources are subject to variation caused by disturbance, changes in season and weather, and other factors. WDFW does not recommend using reports more than six months old.

Appendix B5. WDFW SalmonScape Map



12/15/2022, 11:01:18 AM

- Subject Property
- All SalmonScape Species
- Pink Salmon (Odd Year) Streams
- Winter Steelhead Streams
- Gradient Accessible
- Documented Presence
- Coho Streams
- Fall Chinook Streams
- Documented Presence
- Gradient Accessible



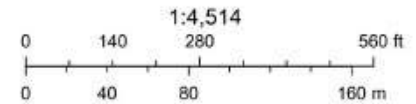
Soundview Consultants

Appendix B6. Puyallup Steam and Wetland Inventory



12/13/2022, 2:16:37 PM

- | | | | |
|------------------|------------------------------|-----------------------------------|-----------------------------|
| Subject Property | Puyallup Wetlands | Estuarine and Marine Deepwater | Freshwater Emergent Wetland |
| Puyallup Streams | Estuarine and Marine Wetland | Freshwater Forested/Shrub Wetland | Freshwater Pond |




U.S. Fish and Wildlife Service, National Standards and Support Team, wetlands_team@fws.gov, Maxar

Soundview Consultants

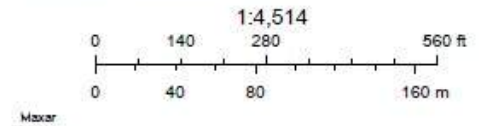
Appendix B7. Pierce County Stream and Wetland Inventory



9/20/2022, 3:47:33 PM

 Pierce - Parcels_Query result

 Pierce - Streams



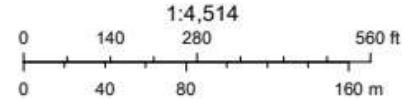
Soundview Consultants

Appendix B8. USFWS NWI Map



12/15/2022, 11:36:56 AM

- Subject Property
- Estuarine and Marine Wetland
- Freshwater Pond
- Wetlands:
- Freshwater Emergent Wetland
- Lake
- Estuarine and Marine Deepwater
- Freshwater Forested/Shrub Wetland
- Other



U.S. Fish and Wildlife Service, National Standards and Support Team, wetlands_team@fws.gov, Maxar

Soundview Consultants

Appendix C – Existing Conditions Exhibit

TODD ROAD - EXISTING CONDITIONS




Soundview Consultants LLC
 Environmental Assessment • Planning • Land Use Solutions
 2907 Harborview Dr., Suite D, Gig Harbor, WA 98335
 Phone: (253) 514-8952 Fax: (253) 514-8954
 www.soundviewconsultants.com

TODD ROAD
 221 TODD RD NW
 PUYALLUP, WA 98371

PIERCE COUNTY PARCEL NUMBERS:
 0420211002 & 0420211012

DATE: 10/7/2022
JOB: 1520.0006
BY: RJK
SCALE: 1" = 120'
FIGURE NO. 1

Appendix D – Data Forms

WETLAND DETERMINATION DATA FORM – Western Mountains, Valleys, and Coast Region

Project/Site: 1649.0001 - Todd Rd. City/County: Puyallup/Pierce Sampling Date: 10/5/2016
 Applicant/Owner: Vector Real Estate Corp. State: WA Sampling Point: DP-1
 Investigator(s): A. Callender / M. DeCaro Section, Township, Range: 21 / 20N / 04E
 Landform (hillslope, terrace, etc.): Valley Local relief (concave, convex, none): None Slope (%): <5
 Subregion (LRR): A2 Lat: 47.212955 Long: -122.297979 Datum: WGS 84
 Soil Map Unit Name: Puyallup Fine Sandy Loam NWI classification: N/A

Are climatic / hydrologic conditions on the site typical for this time of year? Yes No (If no, explain in Remarks.)
 Are Vegetation , Soil , or Hydrology _____ significantly disturbed? Are "Normal Circumstances" present? Yes No
 Are Vegetation _____, Soil _____, or Hydrology _____ naturally problematic? (If needed, explain any answers in Remarks.)

SUMMARY OF FINDINGS – Attach site map showing sampling point locations, transects, important features, etc.

Hydrophytic Vegetation Present? Yes <input checked="" type="checkbox"/> No <input type="checkbox"/> Hydric Soil Present? Yes <input type="checkbox"/> No <input checked="" type="checkbox"/> Wetland Hydrology Present? Yes <input type="checkbox"/> No <input checked="" type="checkbox"/>	Is the Sampled Area within a Wetland? Yes <input type="checkbox"/> No <input checked="" type="checkbox"/>
Remarks: Not all three wetland criteria observed; only hydrophytic vegetation present. Recently plowed agricultural field.	

VEGETATION – Use scientific names of plants.

	Absolute % Cover	Dominant Species?	Indicator Status	
Tree Stratum (Plot size: <u>30 ft</u>)				
1. _____	_____	_____	_____	Dominance Test worksheet: Number of Dominant Species That Are OBL, FACW, or FAC: <u>1</u> (A) Total Number of Dominant Species Across All Strata: <u>2</u> (B) Percent of Dominant Species That Are OBL, FACW, or FAC: <u>50</u> (A/B)
2. _____	_____	_____	_____	
3. _____	_____	_____	_____	
4. _____	_____	_____	_____	
_____	<u>0</u>	= Total Cover		
Sapling/Shrub Stratum (Plot size: <u>15 ft</u>)				
1. _____	_____	_____	_____	Prevalence Index worksheet: Total % Cover of: _____ Multiply by: OBL species _____ x 1 = _____ FACW species <u>6</u> x 2 = <u>12</u> FAC species _____ x 3 = _____ FACU species _____ x 4 = _____ UPL species <u>2</u> x 5 = <u>10</u> Column Totals: <u>8</u> (A) <u>22</u> (B) Prevalence Index = B/A = <u>2.75</u>
2. _____	_____	_____	_____	
3. _____	_____	_____	_____	
4. _____	_____	_____	_____	
5. _____	<u>0</u>	= Total Cover		
Herb Stratum (Plot size: <u>5 ft</u>)				
1. <u>Phalaris arundinacea</u>	<u>5</u>	<u>Yes</u>	<u>FACW</u>	Hydrophytic Vegetation Indicators: <input type="checkbox"/> Rapid Test for Hydrophytic Vegetation <input type="checkbox"/> Dominance Test is >50% <input checked="" type="checkbox"/> Prevalence Index is ≤3.0 ¹ <input type="checkbox"/> Morphological Adaptations ¹ (Provide supporting data in Remarks or on a separate sheet) <input type="checkbox"/> Wetland Non-Vascular Plants ¹ <input type="checkbox"/> Problematic Hydrophytic Vegetation ¹ (Explain) ¹ Indicators of hydric soil and wetland hydrology must be present, unless disturbed or problematic.
2. <u>Sonchus oleraceus</u>	<u>2</u>	<u>Yes</u>	<u>UPL</u>	
3. <u>Epilobium ciliatum</u>	<u>1</u>	<u>No</u>	<u>FACW</u>	
4. _____	_____	_____	_____	
5. _____	_____	_____	_____	
6. _____	_____	_____	_____	
7. _____	_____	_____	_____	
8. _____	_____	_____	_____	
9. _____	_____	_____	_____	
10. _____	_____	_____	_____	
11. _____	<u>8</u>	= Total Cover		
Woody Vine Stratum (Plot size: <u>30 ft</u>)				
1. _____	_____	_____	_____	Hydrophytic Vegetation Present? Yes <input checked="" type="checkbox"/> No <input type="checkbox"/>
2. _____	_____	_____	_____	
				Hydrophytic Vegetation Present? Yes <input checked="" type="checkbox"/> No <input type="checkbox"/>
_____ = Total Cover				
% Bare Ground in Herb Stratum <u>92</u>				

Remarks: Hydrophytic vegetation criteria observed through the prevalence index. Contains <10% vegetation in herb stratum.

SOIL

Sampling Point: DP-1

Profile Description: (Describe to the depth needed to document the indicator or confirm the absence of indicators.)								
Depth (inches)	Matrix		Redox Features			Loc ²	Texture	Remarks
	Color (moist)	%	Color (moist)	%	Type ¹			
0-6	10YR 4/2	100	-	-	-	-	SaLo	Sandy loam
6-18	10YR 5/3	98	7.5YR 5/6	2	C	M	Silo	Silty loam; relict redox features
18-20	10YR 5/2	90	7.5YR 5/6	10	C	M	SiLo	Silty loam; relict redox features
¹ Type: C=Concentration, D=Depletion, RM=Reduced Matrix, CS=Covered or Coated Sand Grains. ² Location: PL=Pore Lining, M=Matrix.								
Hydric Soil Indicators: (Applicable to all LRRs, unless otherwise noted.)						Indicators for Problematic Hydric Soils³:		
<input type="checkbox"/> Histosol (A1)			<input type="checkbox"/> Sandy Redox (S5)			<input type="checkbox"/> 2 cm Muck (A10)		
<input type="checkbox"/> Histic Epipedon (A2)			<input type="checkbox"/> Stripped Matrix (S6)			<input type="checkbox"/> Red Parent Material (TF2)		
<input type="checkbox"/> Black Histic (A3)			<input type="checkbox"/> Loamy Mucky Mineral (F1) (except MLRA 1)			<input type="checkbox"/> Very Shallow Dark Surface (TF12)		
<input type="checkbox"/> Hydrogen Sulfide (A4)			<input type="checkbox"/> Loamy Gleyed Matrix (F2)			<input type="checkbox"/> Other (Explain in Remarks)		
<input type="checkbox"/> Depleted Below Dark Surface (A11)			<input type="checkbox"/> Depleted Matrix (F3)			³ Indicators of hydrophytic vegetation and wetland hydrology must be present, unless disturbed or problematic.		
<input type="checkbox"/> Thick Dark Surface (A12)			<input type="checkbox"/> Redox Dark Surface (F6)					
<input type="checkbox"/> Sandy Mucky Mineral (S1)			<input type="checkbox"/> Depleted Dark Surface (F7)					
<input type="checkbox"/> Sandy Gleyed Matrix (S4)			<input type="checkbox"/> Redox Depressions (F8)					
Restrictive Layer (if present):						Hydric Soil Present? Yes <input type="checkbox"/> No <input checked="" type="checkbox"/>		
Type: _____								
Depth (inches): _____								
Remarks: No hydric soil indicators observed. Redox features observed were relict, hard concretions.								

HYDROLOGY

Wetland Hydrology Indicators:			
Primary Indicators (minimum of one required; check all that apply)		Secondary Indicators (2 or more required)	
<input type="checkbox"/> Surface Water (A1)	<input type="checkbox"/> Water-Stained Leaves (B9) (except MLRA 1, 2, 4A, and 4B)	<input type="checkbox"/> Water-Stained Leaves (B9) (MLRA 1, 2, 4A, and 4B)	
<input type="checkbox"/> High Water Table (A2)	<input type="checkbox"/> Salt Crust (B11)	<input type="checkbox"/> Drainage Patterns (B10)	
<input type="checkbox"/> Saturation (A3)	<input type="checkbox"/> Aquatic Invertebrates (B13)	<input type="checkbox"/> Dry-Season Water Table (C2)	
<input type="checkbox"/> Water Marks (B1)	<input type="checkbox"/> Hydrogen Sulfide Odor (C1)	<input type="checkbox"/> Saturation Visible on Aerial Imagery (C9)	
<input type="checkbox"/> Sediment Deposits (B2)	<input type="checkbox"/> Oxidized Rhizospheres along Living Roots (C3)	<input type="checkbox"/> Geomorphic Position (D2)	
<input type="checkbox"/> Drift Deposits (B3)	<input type="checkbox"/> Presence of Reduced Iron (C4)	<input type="checkbox"/> Shallow Aquitard (D3)	
<input type="checkbox"/> Algal Mat or Crust (B4)	<input type="checkbox"/> Recent Iron Reduction in Tilled Soils (C6)	<input type="checkbox"/> FAC-Neutral Test (D5)	
<input type="checkbox"/> Iron Deposits (B5)	<input type="checkbox"/> Stunted or Stressed Plants (D1) (LRR A)	<input type="checkbox"/> Raised Ant Mounds (D6) (LRR A)	
<input type="checkbox"/> Surface Soil Cracks (B6)	<input type="checkbox"/> Other (Explain in Remarks)	<input type="checkbox"/> Frost-Heave Hummocks (D7)	
<input type="checkbox"/> Inundation Visible on Aerial Imagery (B7)			
<input type="checkbox"/> Sparsely Vegetated Concave Surface (B8)			
Field Observations:		Wetland Hydrology Present? Yes <input type="checkbox"/> No <input checked="" type="checkbox"/>	
Surface Water Present? Yes <input type="checkbox"/> No <input checked="" type="checkbox"/>	Depth (inches): <u>None</u>		
Water Table Present? Yes <input type="checkbox"/> No <input checked="" type="checkbox"/>	Depth (inches): <u>None</u>		
Saturation Present? Yes <input type="checkbox"/> No <input checked="" type="checkbox"/>	Depth (inches): <u>None</u>		
(includes capillary fringe)			
Describe Recorded Data (stream gauge, monitoring well, aerial photos, previous inspections), if available:			
Remarks: No hydrologic indicators observed.			

WETLAND DETERMINATION DATA FORM – Western Mountains, Valleys, and Coast Region

Project/Site: 1649.0001 - Todd Rd. City/County: Puyallup/Pierce Sampling Date: 10/5/2016
 Applicant/Owner: Vector Real Estate Corp. State: WA Sampling Point: DP-2
 Investigator(s): A. Callender / M. DeCaro Section, Township, Range: 21 / 20N / 04E
 Landform (hillslope, terrace, etc.): Valley Local relief (concave, convex, none): None Slope (%): <5
 Subregion (LRR): A2 Lat: 47.213179 Long: -122.298187 Datum: WGS 84
 Soil Map Unit Name: Puyallup Fine Sandy Loam NWI classification: N/A

Are climatic / hydrologic conditions on the site typical for this time of year? Yes No (If no, explain in Remarks.)
 Are Vegetation , Soil , or Hydrology _____ significantly disturbed? Are "Normal Circumstances" present? Yes No
 Are Vegetation _____, Soil _____, or Hydrology _____ naturally problematic? (If needed, explain any answers in Remarks.)

SUMMARY OF FINDINGS – Attach site map showing sampling point locations, transects, important features, etc.

Hydrophytic Vegetation Present? Yes <input type="checkbox"/> No <input checked="" type="checkbox"/> Hydric Soil Present? Yes <input type="checkbox"/> No <input checked="" type="checkbox"/> Wetland Hydrology Present? Yes <input type="checkbox"/> No <input checked="" type="checkbox"/>	Is the Sampled Area within a Wetland? Yes <input type="checkbox"/> No <input checked="" type="checkbox"/>
Remarks: No wetland criteria observed. Recently plowed agricultural field	

VEGETATION – Use scientific names of plants.

<u>Tree Stratum</u> (Plot size: <u>30 ft</u>)	Absolute % Cover	Dominant Species?	Indicator Status	
1. _____	_____	_____	_____	
2. _____	_____	_____	_____	
3. _____	_____	_____	_____	
4. _____	_____	_____	_____	
	<u>0</u>	= Total Cover		
<u>Sapling/Shrub Stratum</u> (Plot size: <u>15 ft</u>)				
1. _____	_____	_____	_____	
2. _____	_____	_____	_____	
3. _____	_____	_____	_____	
4. _____	_____	_____	_____	
5. _____	_____	_____	_____	
	<u>0</u>	= Total Cover		
<u>Herb Stratum</u> (Plot size: <u>5 ft</u>)				
1. <u>Sonchus oleraceus</u>	<u>1</u>	<u>Yes</u>	<u>UPL</u>	
2. _____	_____	_____	_____	
3. _____	_____	_____	_____	
4. _____	_____	_____	_____	
5. _____	_____	_____	_____	
6. _____	_____	_____	_____	
7. _____	_____	_____	_____	
8. _____	_____	_____	_____	
9. _____	_____	_____	_____	
10. _____	_____	_____	_____	
11. _____	_____	_____	_____	
	<u>1</u>	= Total Cover		
<u>Woody Vine Stratum</u> (Plot size: <u>30 ft</u>)				
1. _____	_____	_____	_____	
2. _____	_____	_____	_____	
	<u>0</u>	= Total Cover		
<u>% Bare Ground in Herb Stratum</u> <u>99</u>				

Dominance Test worksheet:
 Number of Dominant Species That Are OBL, FACW, or FAC: 0 (A)
 Total Number of Dominant Species Across All Strata: 1 (B)
 Percent of Dominant Species That Are OBL, FACW, or FAC: 0 (A/B)

Prevalence Index worksheet:
 Total % Cover of: _____ Multiply by:
 OBL species _____ x 1 = _____
 FACW species _____ x 2 = _____
 FAC species _____ x 3 = _____
 FACU species _____ x 4 = _____
 UPL species _____ x 5 = _____
 Column Totals: _____ (A) _____ (B)
 Prevalence Index = B/A = _____

Hydrophytic Vegetation Indicators:
 Rapid Test for Hydrophytic Vegetation
 Dominance Test is >50%
 Prevalence Index is ≤3.0¹
 Morphological Adaptations¹ (Provide supporting data in Remarks or on a separate sheet)
 Wetland Non-Vascular Plants¹
 Problematic Hydrophytic Vegetation¹ (Explain)

¹Indicators of hydric soil and wetland hydrology must be present, unless disturbed or problematic.

Hydrophytic Vegetation Present? Yes <input type="checkbox"/> No <input checked="" type="checkbox"/>

Remarks: No hydrophytic vegetation indicators observed. Contains <5% vegetation in herb stratum

WETLAND DETERMINATION DATA FORM – Western Mountains, Valleys, and Coast Region

Project/Site: 1649.0001 - Todd Rd. City/County: Puyallup/Pierce Sampling Date: 10/5/2016
 Applicant/Owner: Vector Real Estate Corp. State: WA Sampling Point: DP-3
 Investigator(s): A. Callender / M. DeCaro Section, Township, Range: 21 / 20N / 04E
 Landform (hillslope, terrace, etc.): Valley Local relief (concave, convex, none): None Slope (%): <5
 Subregion (LRR): A2 Lat: 47.213275 Long: -122.298651 Datum: WGS 84
 Soil Map Unit Name: Puyallup Fine Sandy Loam NWI classification: N/A

Are climatic / hydrologic conditions on the site typical for this time of year? Yes No (If no, explain in Remarks.)
 Are Vegetation , Soil , or Hydrology _____ significantly disturbed? Are "Normal Circumstances" present? Yes No
 Are Vegetation _____, Soil _____, or Hydrology _____ naturally problematic? (If needed, explain any answers in Remarks.)

SUMMARY OF FINDINGS – Attach site map showing sampling point locations, transects, important features, etc.

Hydrophytic Vegetation Present? Yes <input checked="" type="checkbox"/> No <input type="checkbox"/> Hydric Soil Present? Yes <input type="checkbox"/> No <input checked="" type="checkbox"/> Wetland Hydrology Present? Yes <input type="checkbox"/> No <input checked="" type="checkbox"/>	Is the Sampled Area within a Wetland? Yes <input type="checkbox"/> No <input checked="" type="checkbox"/>
Remarks: Not all three wetland criteria observed; only hydrophytic vegetation present. Recently plowed agricultural field	

VEGETATION – Use scientific names of plants.

<u>Tree Stratum</u> (Plot size: <u>30 ft</u>)	Absolute % Cover	Dominant Species?	Indicator Status	
1. _____	_____	_____	_____	
2. _____	_____	_____	_____	
3. _____	_____	_____	_____	
4. _____	_____	_____	_____	
				0 _____ = Total Cover
<u>Sapling/Shrub Stratum</u> (Plot size: <u>15 ft</u>)				
1. _____	_____	_____	_____	
2. _____	_____	_____	_____	
3. _____	_____	_____	_____	
4. _____	_____	_____	_____	
5. _____	_____	_____	_____	
				0 _____ = Total Cover
<u>Herb Stratum</u> (Plot size: <u>5 ft</u>)				
1. <u>Phalaris arundinacea</u>	<u>3</u>	<u>Yes</u>	<u>FACW</u>	
2. <u>Sonchus oleraceus</u>	<u>1</u>	<u>Yes</u>	<u>UPL</u>	
3. _____	_____	_____	_____	
4. _____	_____	_____	_____	
5. _____	_____	_____	_____	
6. _____	_____	_____	_____	
7. _____	_____	_____	_____	
8. _____	_____	_____	_____	
9. _____	_____	_____	_____	
10. _____	_____	_____	_____	
11. _____	_____	_____	_____	
				4 _____ = Total Cover
<u>Woody Vine Stratum</u> (Plot size: <u>30 ft</u>)				
1. _____	_____	_____	_____	
2. _____	_____	_____	_____	
				0 _____ = Total Cover
<u>% Bare Ground in Herb Stratum</u> <u>96</u>				

Dominance Test worksheet:
 Number of Dominant Species That Are OBL, FACW, or FAC: 1 (A)
 Total Number of Dominant Species Across All Strata: 2 (B)
 Percent of Dominant Species That Are OBL, FACW, or FAC: 50 (A/B)

Prevalence Index worksheet:
 Total % Cover of: _____ Multiply by:
 OBL species _____ x 1 = _____
 FACW species 3 x 2 = 6
 FAC species _____ x 3 = _____
 FACU species _____ x 4 = _____
 UPL species 1 x 5 = 5
 Column Totals: 4 (A) 11 (B)
 Prevalence Index = B/A = 2.75

Hydrophytic Vegetation Indicators:
 Rapid Test for Hydrophytic Vegetation
 Dominance Test is >50%
 Prevalence Index is ≤3.0¹
 Morphological Adaptations¹ (Provide supporting data in Remarks or on a separate sheet)
 Wetland Non-Vascular Plants¹
 Problematic Hydrophytic Vegetation¹ (Explain)

¹Indicators of hydric soil and wetland hydrology must be present, unless disturbed or problematic.

Hydrophytic Vegetation Present? Yes <input checked="" type="checkbox"/> No <input type="checkbox"/>

Remarks: Hydrophytic vegetation criteria observed through the prevalence index. Contains <5% vegetation in herb stratum

SOIL

Sampling Point: DP-3

Profile Description: (Describe to the depth needed to document the indicator or confirm the absence of indicators.)								
Depth (inches)	Matrix		Redox Features			Loc ²	Texture	Remarks
	Color (moist)	%	Color (moist)	%	Type ¹			
0-4	10YR 4/3	100	-	-	-	-	SaLo	Sandy loam
4-8	10YR 4/2	95	10YR 4/4	5	C	M	SaLo	Sandy loam; relict redox features
8-20	10YR 5/2	95	7.5YR 5/6	5	C	M	SaLo	Sandy loam; relict redox features
¹ Type: C=Concentration, D=Depletion, RM=Reduced Matrix, CS=Covered or Coated Sand Grains. ² Location: PL=Pore Lining, M=Matrix.								
Hydric Soil Indicators: (Applicable to all LRRs, unless otherwise noted.)						Indicators for Problematic Hydric Soils³:		
<input type="checkbox"/> Histosol (A1)			<input type="checkbox"/> Sandy Redox (S5)			<input type="checkbox"/> 2 cm Muck (A10)		
<input type="checkbox"/> Histic Epipedon (A2)			<input type="checkbox"/> Stripped Matrix (S6)			<input type="checkbox"/> Red Parent Material (TF2)		
<input type="checkbox"/> Black Histic (A3)			<input type="checkbox"/> Loamy Mucky Mineral (F1) (except MLRA 1)			<input type="checkbox"/> Very Shallow Dark Surface (TF12)		
<input type="checkbox"/> Hydrogen Sulfide (A4)			<input type="checkbox"/> Loamy Gleyed Matrix (F2)			<input type="checkbox"/> Other (Explain in Remarks)		
<input type="checkbox"/> Depleted Below Dark Surface (A11)			<input type="checkbox"/> Depleted Matrix (F3)			³ Indicators of hydrophytic vegetation and wetland hydrology must be present, unless disturbed or problematic.		
<input type="checkbox"/> Thick Dark Surface (A12)			<input type="checkbox"/> Redox Dark Surface (F6)					
<input type="checkbox"/> Sandy Mucky Mineral (S1)			<input type="checkbox"/> Depleted Dark Surface (F7)					
<input type="checkbox"/> Sandy Gleyed Matrix (S4)			<input type="checkbox"/> Redox Depressions (F8)					
Restrictive Layer (if present):						Hydric Soil Present? Yes <input type="checkbox"/> No <input checked="" type="checkbox"/>		
Type: _____								
Depth (inches): _____								
Remarks: No hydric soil indicators observed. Redox features observed were relict, hard concretions.								

HYDROLOGY

Wetland Hydrology Indicators:			
Primary Indicators (minimum of one required; check all that apply)		Secondary Indicators (2 or more required)	
<input type="checkbox"/> Surface Water (A1)	<input type="checkbox"/> Water-Stained Leaves (B9) (except MLRA 1, 2, 4A, and 4B)	<input type="checkbox"/> Water-Stained Leaves (B9) (MLRA 1, 2, 4A, and 4B)	
<input type="checkbox"/> High Water Table (A2)	<input type="checkbox"/> Salt Crust (B11)	<input type="checkbox"/> Drainage Patterns (B10)	
<input type="checkbox"/> Saturation (A3)	<input type="checkbox"/> Aquatic Invertebrates (B13)	<input type="checkbox"/> Dry-Season Water Table (C2)	
<input type="checkbox"/> Water Marks (B1)	<input type="checkbox"/> Hydrogen Sulfide Odor (C1)	<input type="checkbox"/> Saturation Visible on Aerial Imagery (C9)	
<input type="checkbox"/> Sediment Deposits (B2)	<input type="checkbox"/> Oxidized Rhizospheres along Living Roots (C3)	<input type="checkbox"/> Geomorphic Position (D2)	
<input type="checkbox"/> Drift Deposits (B3)	<input type="checkbox"/> Presence of Reduced Iron (C4)	<input type="checkbox"/> Shallow Aquitard (D3)	
<input type="checkbox"/> Algal Mat or Crust (B4)	<input type="checkbox"/> Recent Iron Reduction in Tilled Soils (C6)	<input type="checkbox"/> FAC-Neutral Test (D5)	
<input type="checkbox"/> Iron Deposits (B5)	<input type="checkbox"/> Stunted or Stressed Plants (D1) (LRR A)	<input type="checkbox"/> Raised Ant Mounds (D6) (LRR A)	
<input type="checkbox"/> Surface Soil Cracks (B6)	<input type="checkbox"/> Other (Explain in Remarks)	<input type="checkbox"/> Frost-Heave Hummocks (D7)	
<input type="checkbox"/> Inundation Visible on Aerial Imagery (B7)			
<input type="checkbox"/> Sparsely Vegetated Concave Surface (B8)			
Field Observations:		Wetland Hydrology Present? Yes <input type="checkbox"/> No <input checked="" type="checkbox"/>	
Surface Water Present? Yes <input type="checkbox"/> No <input checked="" type="checkbox"/>	Depth (inches): <u>None</u>		
Water Table Present? Yes <input type="checkbox"/> No <input checked="" type="checkbox"/>	Depth (inches): <u>None</u>		
Saturation Present? Yes <input type="checkbox"/> No <input checked="" type="checkbox"/>	Depth (inches): <u>None</u>		
(includes capillary fringe)			
Describe Recorded Data (stream gauge, monitoring well, aerial photos, previous inspections), if available:			
Remarks: No hydrologic indicators observed.			

WETLAND DETERMINATION DATA FORM – Western Mountains, Valleys, and Coast Region

Project/Site: 1649.0001 - Todd Rd. City/County: Puyallup/Pierce Sampling Date: 10/5/2016
 Applicant/Owner: Vector Real Estate Corp. State: WA Sampling Point: DP-4
 Investigator(s): A. Callender / M. DeCaro Section, Township, Range: 21 / 20N / 04E
 Landform (hillslope, terrace, etc.): Valley Local relief (concave, convex, none): None Slope (%): <5
 Subregion (LRR): A2 Lat: 47.213374 Long: -122.298355 Datum: WGS 84
 Soil Map Unit Name: Sultan Silt Loam NWI classification: N/A

Are climatic / hydrologic conditions on the site typical for this time of year? Yes No (If no, explain in Remarks.)
 Are Vegetation , Soil , or Hydrology _____ significantly disturbed? Are "Normal Circumstances" present? Yes No
 Are Vegetation _____, Soil _____, or Hydrology _____ naturally problematic? (If needed, explain any answers in Remarks.)

SUMMARY OF FINDINGS – Attach site map showing sampling point locations, transects, important features, etc.

Hydrophytic Vegetation Present? Yes <input checked="" type="checkbox"/> No <input type="checkbox"/> Hydric Soil Present? Yes <input type="checkbox"/> No <input checked="" type="checkbox"/> Wetland Hydrology Present? Yes <input type="checkbox"/> No <input checked="" type="checkbox"/>	Is the Sampled Area within a Wetland? Yes <input type="checkbox"/> No <input checked="" type="checkbox"/>
Remarks: Not all three wetland criteria observed; only hydrophytic vegetation present. Recently plowed agricultural field	

VEGETATION – Use scientific names of plants.

<u>Tree Stratum</u> (Plot size: <u>30 ft</u>)	<u>Absolute % Cover</u>	<u>Dominant Species?</u>	<u>Indicator Status</u>	
1. _____	_____	_____	_____	
2. _____	_____	_____	_____	
3. _____	_____	_____	_____	
4. _____	_____	_____	_____	
	<u>0</u>	= Total Cover		
<u>Sapling/Shrub Stratum</u> (Plot size: <u>15 ft</u>)				
1. _____	_____	_____	_____	
2. _____	_____	_____	_____	
3. _____	_____	_____	_____	
4. _____	_____	_____	_____	
5. _____	_____	_____	_____	
	<u>0</u>	= Total Cover		
<u>Herb Stratum</u> (Plot size: <u>5 ft</u>)				
1. <u>Phalaris arundinacea</u>	<u>5</u>	<u>Yes</u>	<u>FACW</u>	
2. <u>Sonchus oleraceus</u>	<u>1</u>	<u>No</u>	<u>UPL</u>	
3. <u>Equisetum arvense</u>	<u>1</u>	<u>No</u>	<u>FAC</u>	
4. <u>Trifolium repens</u>	<u>1</u>	<u>No</u>	<u>FAC</u>	
5. _____	_____	_____	_____	
6. _____	_____	_____	_____	
7. _____	_____	_____	_____	
8. _____	_____	_____	_____	
9. _____	_____	_____	_____	
10. _____	_____	_____	_____	
11. _____	_____	_____	_____	
	<u>8</u>	= Total Cover		
<u>Woody Vine Stratum</u> (Plot size: <u>30 ft</u>)				
1. _____	_____	_____	_____	
2. _____	_____	_____	_____	
	<u>0</u>	= Total Cover		
<u>% Bare Ground in Herb Stratum</u> <u>92</u>				

Dominance Test worksheet:
 Number of Dominant Species That Are OBL, FACW, or FAC: 1 (A)
 Total Number of Dominant Species Across All Strata: 1 (B)
 Percent of Dominant Species That Are OBL, FACW, or FAC: 100 (A/B)

Prevalence Index worksheet:
 Total % Cover of: _____ Multiply by:
 OBL species _____ x 1 = _____
 FACW species _____ x 2 = _____
 FAC species _____ x 3 = _____
 FACU species _____ x 4 = _____
 UPL species _____ x 5 = _____
 Column Totals: _____ (A) _____ (B)
 Prevalence Index = B/A = _____

Hydrophytic Vegetation Indicators:
 Rapid Test for Hydrophytic Vegetation
 Dominance Test is >50%
 Prevalence Index is ≤3.0¹
 Morphological Adaptations¹ (Provide supporting data in Remarks or on a separate sheet)
 Wetland Non-Vascular Plants¹
 Problematic Hydrophytic Vegetation¹ (Explain)
¹Indicators of hydric soil and wetland hydrology must be present, unless disturbed or problematic.

Hydrophytic Vegetation Present? Yes No

Remarks: Hydrophytic vegetation criteria observed through the dominance test. Contains <10% vegetation in herb stratum.

SOIL

Sampling Point: DP-4

Profile Description: (Describe to the depth needed to document the indicator or confirm the absence of indicators.)								
Depth (inches)	Matrix		Redox Features			Loc ²	Texture	Remarks
	Color (moist)	%	Color (moist)	%	Type ¹			
0-8	10YR 4/3	100	-	-	-	-	SaLo	Sandy loam
8-14	10YR 4/2	95	7.5YR 4/6	5	C	M	SaLo	Sandy loam; relict redox features
14-18	10YR 5/2	80	7.5YR 5/6	20	C	M	SaLo	Sandy loam; relict redox features

¹Type: C=Concentration, D=Depletion, RM=Reduced Matrix, CS=Covered or Coated Sand Grains. ²Location: PL=Pore Lining, M=Matrix.

Hydric Soil Indicators: (Applicable to all LRRs, unless otherwise noted.) <input type="checkbox"/> Histosol (A1) <input type="checkbox"/> Histic Epipedon (A2) <input type="checkbox"/> Black Histic (A3) <input type="checkbox"/> Hydrogen Sulfide (A4) <input type="checkbox"/> Depleted Below Dark Surface (A11) <input type="checkbox"/> Thick Dark Surface (A12) <input type="checkbox"/> Sandy Mucky Mineral (S1) <input type="checkbox"/> Sandy Gleyed Matrix (S4)	<input type="checkbox"/> Sandy Redox (S5) <input type="checkbox"/> Stripped Matrix (S6) <input type="checkbox"/> Loamy Mucky Mineral (F1) (except MLRA 1) <input type="checkbox"/> Loamy Gleyed Matrix (F2) <input type="checkbox"/> Depleted Matrix (F3) <input type="checkbox"/> Redox Dark Surface (F6) <input type="checkbox"/> Depleted Dark Surface (F7) <input type="checkbox"/> Redox Depressions (F8)	Indicators for Problematic Hydric Soils³: <input type="checkbox"/> 2 cm Muck (A10) <input type="checkbox"/> Red Parent Material (TF2) <input type="checkbox"/> Very Shallow Dark Surface (TF12) <input type="checkbox"/> Other (Explain in Remarks)
----------------------------------------------------------------------------------------------------------------------------------------------------------------------------------------------------------------------------------------------------------------------------------------------------------------------------------------------------------------------------------------------------------------------------------------------------------------------------------------------------------	-------------------------------------------------------------------------------------------------------------------------------------------------------------------------------------------------------------------------------------------------------------------------------------------------------------------------------------------------------------------------------------------------------------------------------------	-----------------------------------------------------------------------------------------------------------------------------------------------------------------------------------------------------------------------------------------------------------------------------------

³Indicators of hydrophytic vegetation and wetland hydrology must be present, unless disturbed or problematic.

Restrictive Layer (if present): Type: _____ Depth (inches): _____	Hydric Soil Present? Yes <input type="checkbox"/> No <input checked="" type="checkbox"/>
--------------------------------------------------------------------------------	-------------------------------------------------------------------------------------------------

Remarks: No hydric soil indicators observed. Redox features observed were relict features along old root channels.

HYDROLOGY

Wetland Hydrology Indicators: Primary Indicators (minimum of one required; check all that apply)		Secondary Indicators (2 or more required)	
<input type="checkbox"/> Surface Water (A1) <input type="checkbox"/> High Water Table (A2) <input type="checkbox"/> Saturation (A3) <input type="checkbox"/> Water Marks (B1) <input type="checkbox"/> Sediment Deposits (B2) <input type="checkbox"/> Drift Deposits (B3) <input type="checkbox"/> Algal Mat or Crust (B4) <input type="checkbox"/> Iron Deposits (B5) <input type="checkbox"/> Surface Soil Cracks (B6) <input type="checkbox"/> Inundation Visible on Aerial Imagery (B7) <input type="checkbox"/> Sparsely Vegetated Concave Surface (B8)	<input type="checkbox"/> Water-Stained Leaves (B9) (except MLRA 1, 2, 4A, and 4B) <input type="checkbox"/> Salt Crust (B11) <input type="checkbox"/> Aquatic Invertebrates (B13) <input type="checkbox"/> Hydrogen Sulfide Odor (C1) <input type="checkbox"/> Oxidized Rhizospheres along Living Roots (C3) <input type="checkbox"/> Presence of Reduced Iron (C4) <input type="checkbox"/> Recent Iron Reduction in Tilled Soils (C6) <input type="checkbox"/> Stunted or Stressed Plants (D1) (LRR A) <input type="checkbox"/> Other (Explain in Remarks)	<input type="checkbox"/> Water-Stained Leaves (B9) (MLRA 1, 2, 4A, and 4B) <input type="checkbox"/> Drainage Patterns (B10) <input type="checkbox"/> Dry-Season Water Table (C2) <input type="checkbox"/> Saturation Visible on Aerial Imagery (C9) <input type="checkbox"/> Geomorphic Position (D2) <input type="checkbox"/> Shallow Aquitard (D3) <input type="checkbox"/> FAC-Neutral Test (D5) <input type="checkbox"/> Raised Ant Mounds (D6) (LRR A) <input type="checkbox"/> Frost-Heave Hummocks (D7)	
Field Observations: Surface Water Present? Yes <input type="checkbox"/> No <input checked="" type="checkbox"/> Depth (inches): <u>None</u> Water Table Present? Yes <input type="checkbox"/> No <input checked="" type="checkbox"/> Depth (inches): <u>None</u> Saturation Present? Yes <input type="checkbox"/> No <input checked="" type="checkbox"/> Depth (inches): <u>None</u> (includes capillary fringe)		Wetland Hydrology Present? Yes <input type="checkbox"/> No <input checked="" type="checkbox"/>	
Describe Recorded Data (stream gauge, monitoring well, aerial photos, previous inspections), if available:			
Remarks: No hydrologic indicators observed.			

WETLAND DETERMINATION DATA FORM – Western Mountains, Valleys, and Coast Region

Project/Site: 1649.0001 - Todd Rd. City/County: Puyallup/Pierce Sampling Date: 10/5/2016
 Applicant/Owner: Vector Real Estate Corp. State: WA Sampling Point: DP-5
 Investigator(s): A. Callender / M. DeCaro Section, Township, Range: 21 / 20N / 04E
 Landform (hillslope, terrace, etc.): Valley Local relief (concave, convex, none): None Slope (%): <5
 Subregion (LRR): A2 Lat: 47.213254 Long: -122.29841 Datum: WGS 84
 Soil Map Unit Name: Sultan Silt Loam NWI classification: N/A

Are climatic / hydrologic conditions on the site typical for this time of year? Yes No (If no, explain in Remarks.)
 Are Vegetation , Soil , or Hydrology _____ significantly disturbed? Are "Normal Circumstances" present? Yes No
 Are Vegetation _____, Soil _____, or Hydrology _____ naturally problematic? (If needed, explain any answers in Remarks.)

SUMMARY OF FINDINGS – Attach site map showing sampling point locations, transects, important features, etc.

Hydrophytic Vegetation Present? Yes <input checked="" type="checkbox"/> No <input type="checkbox"/> Hydric Soil Present? Yes <input type="checkbox"/> No <input checked="" type="checkbox"/> Wetland Hydrology Present? Yes <input type="checkbox"/> No <input checked="" type="checkbox"/>	Is the Sampled Area within a Wetland? Yes <input type="checkbox"/> No <input checked="" type="checkbox"/>
Remarks: Not all three wetland criteria observed; only hydrophytic vegetation present. Recently plowed agricultural field	

VEGETATION – Use scientific names of plants.

<u>Tree Stratum</u> (Plot size: <u>30 ft</u>)	<u>Absolute % Cover</u>	<u>Dominant Species?</u>	<u>Indicator Status</u>	
1. _____	_____	_____	_____	
2. _____	_____	_____	_____	
3. _____	_____	_____	_____	
4. _____	_____	_____	_____	
				0 _____ = Total Cover
<u>Sapling/Shrub Stratum</u> (Plot size: <u>15 ft</u>)				
1. _____	_____	_____	_____	
2. _____	_____	_____	_____	
3. _____	_____	_____	_____	
4. _____	_____	_____	_____	
5. _____	_____	_____	_____	
				0 _____ = Total Cover
<u>Herb Stratum</u> (Plot size: <u>5 ft</u>)				
1. <u>Phalaris arundinacea</u>	4	Yes	FACW	
2. <u>Equisetum arvense</u>	2	Yes	FAC	
3. <u>Sonchus oleraceus</u>	1	No	UPL	
4. _____	_____	_____	_____	
5. _____	_____	_____	_____	
6. _____	_____	_____	_____	
7. _____	_____	_____	_____	
8. _____	_____	_____	_____	
9. _____	_____	_____	_____	
10. _____	_____	_____	_____	
11. _____	_____	_____	_____	
				7 _____ = Total Cover
<u>Woody Vine Stratum</u> (Plot size: <u>30 ft</u>)				
1. _____	_____	_____	_____	
2. _____	_____	_____	_____	
				0 _____ = Total Cover
<u>% Bare Ground in Herb Stratum</u> <u>93</u>				

Dominance Test worksheet:
 Number of Dominant Species That Are OBL, FACW, or FAC: 2 (A)
 Total Number of Dominant Species Across All Strata: 2 (B)
 Percent of Dominant Species That Are OBL, FACW, or FAC: 100 (A/B)

Prevalence Index worksheet:
 Total % Cover of: _____ Multiply by:
 OBL species _____ x 1 = _____
 FACW species _____ x 2 = _____
 FAC species _____ x 3 = _____
 FACU species _____ x 4 = _____
 UPL species _____ x 5 = _____
 Column Totals: _____ (A) _____ (B)
 Prevalence Index = B/A = _____

Hydrophytic Vegetation Indicators:
 Rapid Test for Hydrophytic Vegetation
 Dominance Test is >50%
 Prevalence Index is ≤3.0¹
 Morphological Adaptations¹ (Provide supporting data in Remarks or on a separate sheet)
 Wetland Non-Vascular Plants¹
 Problematic Hydrophytic Vegetation¹ (Explain)
¹Indicators of hydric soil and wetland hydrology must be present, unless disturbed or problematic.

Hydrophytic Vegetation Present? Yes No

Remarks: Hydrophytic vegetation criteria observed through the dominance test. Contains <10% vegetation in herb stratum

SOIL

Sampling Point: DP-5

Profile Description: (Describe to the depth needed to document the indicator or confirm the absence of indicators.)								
Depth (inches)	Matrix		Redox Features			Loc ²	Texture	Remarks
	Color (moist)	%	Color (moist)	%	Type ¹			
0-2	10YR 4/3	100					SaLo	Sandy loam
2-14	10YR 4/2	85	10YR 4/6	15	C	M	SaLo	Sandy loam; relict redox features
14-18	10YR 5/2	75	7.5YR 5/6	25	C	M	SiLo	Silty loam; relict redox features
¹ Type: C=Concentration, D=Depletion, RM=Reduced Matrix, CS=Covered or Coated Sand Grains. ² Location: PL=Pore Lining, M=Matrix.								
Hydric Soil Indicators: (Applicable to all LRRs, unless otherwise noted.) <input type="checkbox"/> Histosol (A1) <input type="checkbox"/> Sandy Redox (S5) <input type="checkbox"/> Histic Epipedon (A2) <input type="checkbox"/> Stripped Matrix (S6) <input type="checkbox"/> Black Histic (A3) <input type="checkbox"/> Loamy Mucky Mineral (F1) (except MLRA 1) <input type="checkbox"/> Hydrogen Sulfide (A4) <input type="checkbox"/> Loamy Gleyed Matrix (F2) <input type="checkbox"/> Depleted Below Dark Surface (A11) <input type="checkbox"/> Depleted Matrix (F3) <input type="checkbox"/> Thick Dark Surface (A12) <input type="checkbox"/> Redox Dark Surface (F6) <input type="checkbox"/> Sandy Mucky Mineral (S1) <input type="checkbox"/> Depleted Dark Surface (F7) <input type="checkbox"/> Sandy Gleyed Matrix (S4) <input type="checkbox"/> Redox Depressions (F8)						Indicators for Problematic Hydric Soils³: <input type="checkbox"/> 2 cm Muck (A10) <input type="checkbox"/> Red Parent Material (TF2) <input type="checkbox"/> Very Shallow Dark Surface (TF12) <input type="checkbox"/> Other (Explain in Remarks)		
Restrictive Layer (if present): Type: _____ Depth (inches): _____						Hydric Soil Present? Yes <input type="checkbox"/> No <input checked="" type="checkbox"/>		
Remarks: No hydric soil indicators observed. Redox features observed were relict, hard concretions with sharp edges.								

HYDROLOGY

Wetland Hydrology Indicators:		
Primary Indicators (minimum of one required; check all that apply)	Secondary Indicators (2 or more required)	
<input type="checkbox"/> Surface Water (A1) <input type="checkbox"/> High Water Table (A2) <input type="checkbox"/> Saturation (A3) <input type="checkbox"/> Water Marks (B1) <input type="checkbox"/> Sediment Deposits (B2) <input type="checkbox"/> Drift Deposits (B3) <input type="checkbox"/> Algal Mat or Crust (B4) <input type="checkbox"/> Iron Deposits (B5) <input type="checkbox"/> Surface Soil Cracks (B6) <input type="checkbox"/> Inundation Visible on Aerial Imagery (B7) <input type="checkbox"/> Sparsely Vegetated Concave Surface (B8)	<input type="checkbox"/> Water-Stained Leaves (B9) (except MLRA 1, 2, 4A, and 4B) <input type="checkbox"/> Salt Crust (B11) <input type="checkbox"/> Aquatic Invertebrates (B13) <input type="checkbox"/> Hydrogen Sulfide Odor (C1) <input type="checkbox"/> Oxidized Rhizospheres along Living Roots (C3) <input type="checkbox"/> Presence of Reduced Iron (C4) <input type="checkbox"/> Recent Iron Reduction in Tilled Soils (C6) <input type="checkbox"/> Stunted or Stressed Plants (D1) (LRR A) <input type="checkbox"/> Other (Explain in Remarks)	
	<input type="checkbox"/> Water-Stained Leaves (B9) (MLRA 1, 2, 4A, and 4B) <input type="checkbox"/> Drainage Patterns (B10) <input type="checkbox"/> Dry-Season Water Table (C2) <input type="checkbox"/> Saturation Visible on Aerial Imagery (C9) <input type="checkbox"/> Geomorphic Position (D2) <input type="checkbox"/> Shallow Aquitard (D3) <input type="checkbox"/> FAC-Neutral Test (D5) <input type="checkbox"/> Raised Ant Mounds (D6) (LRR A) <input type="checkbox"/> Frost-Heave Hummocks (D7)	
Field Observations: Surface Water Present? Yes <input type="checkbox"/> No <input checked="" type="checkbox"/> Depth (inches): <u>None</u> Water Table Present? Yes <input type="checkbox"/> No <input checked="" type="checkbox"/> Depth (inches): <u>None</u> Saturation Present? Yes <input type="checkbox"/> No <input checked="" type="checkbox"/> Depth (inches): <u>None</u> (includes capillary fringe)		
Wetland Hydrology Present? Yes <input type="checkbox"/> No <input checked="" type="checkbox"/>		
Describe Recorded Data (stream gauge, monitoring well, aerial photos, previous inspections), if available:		
Remarks: No hydrologic indicators observed.		

WETLAND DETERMINATION DATA FORM – Western Mountains, Valleys, and Coast Region

Project/Site: 1649.0001 - Todd Rd. City/County: Puyallup/Pierce Sampling Date: 10/5/2016
 Applicant/Owner: Vector Real Estate Corp. State: WA Sampling Point: DP-6
 Investigator(s): A. Callender / M. DeCaro Section, Township, Range: 21 / 20N / 04E
 Landform (hillslope, terrace, etc.): Valley Local relief (concave, convex, none): None Slope (%): <5
 Subregion (LRR): A2 Lat: 47.212944 Long: -122.298446 Datum: WGS 84
 Soil Map Unit Name: Puyallup Fine Sandy Loam NWI classification: N/A

Are climatic / hydrologic conditions on the site typical for this time of year? Yes No (If no, explain in Remarks.)
 Are Vegetation , Soil , or Hydrology _____ significantly disturbed? Are "Normal Circumstances" present? Yes No
 Are Vegetation _____, Soil _____, or Hydrology _____ naturally problematic? (If needed, explain any answers in Remarks.)

SUMMARY OF FINDINGS – Attach site map showing sampling point locations, transects, important features, etc.

Hydrophytic Vegetation Present? Yes <input type="checkbox"/> No <input checked="" type="checkbox"/> Hydric Soil Present? Yes <input type="checkbox"/> No <input checked="" type="checkbox"/> Wetland Hydrology Present? Yes <input type="checkbox"/> No <input checked="" type="checkbox"/>	Is the Sampled Area within a Wetland? Yes <input type="checkbox"/> No <input checked="" type="checkbox"/>
Remarks: No wetland criteria observed. Recently plowed agricultural field	

VEGETATION – Use scientific names of plants.

<u>Tree Stratum</u> (Plot size: <u>30 ft</u>)	Absolute % Cover	Dominant Species?	Indicator Status	
1. _____	_____	_____	_____	
2. _____	_____	_____	_____	
3. _____	_____	_____	_____	
4. _____	_____	_____	_____	
				0 _____ = Total Cover
<u>Sapling/Shrub Stratum</u> (Plot size: <u>15 ft</u>)				
1. _____	_____	_____	_____	
2. _____	_____	_____	_____	
3. _____	_____	_____	_____	
4. _____	_____	_____	_____	
5. _____	_____	_____	_____	
				0 _____ = Total Cover
<u>Herb Stratum</u> (Plot size: <u>5 ft</u>)				
1. <u>Phalaris arundinacea</u>	<u>2</u>	<u>Yes</u>	<u>FACW</u>	
2. <u>Sonchus oleraceus</u>	<u>2</u>	<u>Yes</u>	<u>UPL</u>	
3. _____	_____	_____	_____	
4. _____	_____	_____	_____	
5. _____	_____	_____	_____	
6. _____	_____	_____	_____	
7. _____	_____	_____	_____	
8. _____	_____	_____	_____	
9. _____	_____	_____	_____	
10. _____	_____	_____	_____	
11. _____	_____	_____	_____	
				4 _____ = Total Cover
<u>Woody Vine Stratum</u> (Plot size: <u>30 ft</u>)				
1. _____	_____	_____	_____	
2. _____	_____	_____	_____	
				0 _____ = Total Cover
<u>% Bare Ground in Herb Stratum</u> <u>96</u>				

Dominance Test worksheet:
 Number of Dominant Species That Are OBL, FACW, or FAC: 1 (A)
 Total Number of Dominant Species Across All Strata: 2 (B)
 Percent of Dominant Species That Are OBL, FACW, or FAC: 50 (A/B)

Prevalence Index worksheet:
 Total % Cover of: _____ Multiply by:
 OBL species _____ x 1 = _____
 FACW species 2 x 2 = 4
 FAC species _____ x 3 = _____
 FACU species _____ x 4 = _____
 UPL species 2 x 5 = 10
 Column Totals: 4 (A) 14 (B)
 Prevalence Index = B/A = 3.5

Hydrophytic Vegetation Indicators:
 Rapid Test for Hydrophytic Vegetation
 Dominance Test is >50%
 Prevalence Index is ≤3.0¹
 Morphological Adaptations¹ (Provide supporting data in Remarks or on a separate sheet)
 Wetland Non-Vascular Plants¹
 Problematic Hydrophytic Vegetation¹ (Explain)
¹Indicators of hydric soil and wetland hydrology must be present, unless disturbed or problematic.

Hydrophytic Vegetation Present? Yes No

Remarks: No hydrophytic vegetation indicators observed. Contains <5% vegetation in herb stratum

SOIL

Sampling Point: DP-6

Profile Description: (Describe to the depth needed to document the indicator or confirm the absence of indicators.)

Depth (inches)	Matrix		Redox Features			Loc ²	Texture	Remarks
	Color (moist)	%	Color (moist)	%	Type ¹			
0-4	10YR 4/2	100	-	-	-	-	SiLo	Silty loam
4-8	10YR 4/3	100					SiLo	Silty loam
8-18	10YR 5/2	>99	10YR 5/4	<1	C	M	SiLo	Silty loam; relict redox features

¹Type: C=Concentration, D=Depletion, RM=Reduced Matrix, CS=Covered or Coated Sand Grains. ²Location: PL=Pore Lining, M=Matrix.

Hydric Soil Indicators: (Applicable to all LRRs, unless otherwise noted.)

<input type="checkbox"/> Histosol (A1)	<input type="checkbox"/> Sandy Redox (S5)	Indicators for Problematic Hydric Soils³: <input type="checkbox"/> 2 cm Muck (A10) <input type="checkbox"/> Red Parent Material (TF2) <input type="checkbox"/> Very Shallow Dark Surface (TF12) <input type="checkbox"/> Other (Explain in Remarks) ³ Indicators of hydrophytic vegetation and wetland hydrology must be present, unless disturbed or problematic.
<input type="checkbox"/> Histic Epipedon (A2)	<input type="checkbox"/> Stripped Matrix (S6)	
<input type="checkbox"/> Black Histic (A3)	<input type="checkbox"/> Loamy Mucky Mineral (F1) (except MLRA 1)	
<input type="checkbox"/> Hydrogen Sulfide (A4)	<input type="checkbox"/> Loamy Gleyed Matrix (F2)	
<input type="checkbox"/> Depleted Below Dark Surface (A11)	<input type="checkbox"/> Depleted Matrix (F3)	
<input type="checkbox"/> Thick Dark Surface (A12)	<input type="checkbox"/> Redox Dark Surface (F6)	
<input type="checkbox"/> Sandy Mucky Mineral (S1)	<input type="checkbox"/> Depleted Dark Surface (F7)	
<input type="checkbox"/> Sandy Gleyed Matrix (S4)	<input type="checkbox"/> Redox Depressions (F8)	

Restrictive Layer (if present):
Type: _____
Depth (inches): _____

Hydric Soil Present? Yes No

Remarks: No hydric soil indicators observed. Redox features observed were relict, hard concretions.

HYDROLOGY

Wetland Hydrology Indicators:

<u>Primary Indicators (minimum of one required; check all that apply)</u>		<u>Secondary Indicators (2 or more required)</u>
<input type="checkbox"/> Surface Water (A1)	<input type="checkbox"/> Water-Stained Leaves (B9) (except MLRA 1, 2, 4A, and 4B)	<input type="checkbox"/> Water-Stained Leaves (B9) (MLRA 1, 2, 4A, and 4B)
<input type="checkbox"/> High Water Table (A2)	<input type="checkbox"/> Salt Crust (B11)	<input type="checkbox"/> Drainage Patterns (B10)
<input type="checkbox"/> Saturation (A3)	<input type="checkbox"/> Aquatic Invertebrates (B13)	<input type="checkbox"/> Dry-Season Water Table (C2)
<input type="checkbox"/> Water Marks (B1)	<input type="checkbox"/> Hydrogen Sulfide Odor (C1)	<input type="checkbox"/> Saturation Visible on Aerial Imagery (C9)
<input type="checkbox"/> Sediment Deposits (B2)	<input type="checkbox"/> Oxidized Rhizospheres along Living Roots (C3)	<input type="checkbox"/> Geomorphic Position (D2)
<input type="checkbox"/> Drift Deposits (B3)	<input type="checkbox"/> Presence of Reduced Iron (C4)	<input type="checkbox"/> Shallow Aquitard (D3)
<input type="checkbox"/> Algal Mat or Crust (B4)	<input type="checkbox"/> Recent Iron Reduction in Tilled Soils (C6)	<input type="checkbox"/> FAC-Neutral Test (D5)
<input type="checkbox"/> Iron Deposits (B5)	<input type="checkbox"/> Stunted or Stressed Plants (D1) (LRR A)	<input type="checkbox"/> Raised Ant Mounds (D6) (LRR A)
<input type="checkbox"/> Surface Soil Cracks (B6)	<input type="checkbox"/> Other (Explain in Remarks)	<input type="checkbox"/> Frost-Heave Hummocks (D7)
<input type="checkbox"/> Inundation Visible on Aerial Imagery (B7)		
<input type="checkbox"/> Sparsely Vegetated Concave Surface (B8)		

Field Observations:

Surface Water Present?	Yes <input type="checkbox"/> No <input checked="" type="checkbox"/>	Depth (inches): <u>None</u>	Wetland Hydrology Present? Yes <input type="checkbox"/> No <input checked="" type="checkbox"/>
Water Table Present?	Yes <input type="checkbox"/> No <input checked="" type="checkbox"/>	Depth (inches): <u>None</u>	
Saturation Present? (includes capillary fringe)	Yes <input type="checkbox"/> No <input checked="" type="checkbox"/>	Depth (inches): <u>None</u>	

Describe Recorded Data (stream gauge, monitoring well, aerial photos, previous inspections), if available:

Remarks: No hydrologic indicators observed.

WETLAND DETERMINATION DATA FORM – Western Mountains, Valleys, and Coast Region

Project/Site: 1649.0001 - Todd Rd. City/County: Puyallup/Pierce Sampling Date: 10/5/2016
 Applicant/Owner: Vector Real Estate Corp. State: WA Sampling Point: DP-7
 Investigator(s): A. Callender / M. DeCaro Section, Township, Range: 21 / 20N / 04E
 Landform (hillslope, terrace, etc.): Valley Local relief (concave, convex, none): None Slope (%): <5
 Subregion (LRR): A2 Lat: 47.212738 Long: -122.298457 Datum: WGS 84
 Soil Map Unit Name: Puyallup Fine Sandy Loam NWI classification: N/A

Are climatic / hydrologic conditions on the site typical for this time of year? Yes No (If no, explain in Remarks.)
 Are Vegetation , Soil , or Hydrology _____ significantly disturbed? Are "Normal Circumstances" present? Yes No
 Are Vegetation _____, Soil _____, or Hydrology _____ naturally problematic? (If needed, explain any answers in Remarks.)

SUMMARY OF FINDINGS – Attach site map showing sampling point locations, transects, important features, etc.

Hydrophytic Vegetation Present? Yes <input type="checkbox"/> No <input checked="" type="checkbox"/> Hydric Soil Present? Yes <input type="checkbox"/> No <input checked="" type="checkbox"/> Wetland Hydrology Present? Yes <input type="checkbox"/> No <input checked="" type="checkbox"/>	Is the Sampled Area within a Wetland? Yes <input type="checkbox"/> No <input checked="" type="checkbox"/>
Remarks: No wetland criteria observed. Recently plowed agricultural field	

VEGETATION – Use scientific names of plants.

<u>Tree Stratum</u> (Plot size: <u>30 ft</u>)	Absolute % Cover	Dominant Species?	Indicator Status	
1. _____	_____	_____	_____	
2. _____	_____	_____	_____	
3. _____	_____	_____	_____	
4. _____	_____	_____	_____	
				0 _____ = Total Cover
<u>Sapling/Shrub Stratum</u> (Plot size: <u>15 ft</u>)				
1. _____	_____	_____	_____	
2. _____	_____	_____	_____	
3. _____	_____	_____	_____	
4. _____	_____	_____	_____	
5. _____	_____	_____	_____	
				0 _____ = Total Cover
<u>Herb Stratum</u> (Plot size: <u>5 ft</u>)				
1. <u>Sonchus oleraceus</u>	4	Yes	UPL	
2. <u>Phalaris arundinacea</u>	1	Yes	FACW	
3. _____	_____	_____	_____	
4. _____	_____	_____	_____	
5. _____	_____	_____	_____	
6. _____	_____	_____	_____	
7. _____	_____	_____	_____	
8. _____	_____	_____	_____	
9. _____	_____	_____	_____	
10. _____	_____	_____	_____	
11. _____	_____	_____	_____	
				5 _____ = Total Cover
<u>Woody Vine Stratum</u> (Plot size: <u>30 ft</u>)				
1. _____	_____	_____	_____	
2. _____	_____	_____	_____	
				0 _____ = Total Cover
<u>% Bare Ground in Herb Stratum</u> <u>95</u>				

Dominance Test worksheet:
 Number of Dominant Species That Are OBL, FACW, or FAC: 1 (A)
 Total Number of Dominant Species Across All Strata: 2 (B)
 Percent of Dominant Species That Are OBL, FACW, or FAC: 50 (A/B)

Prevalence Index worksheet:
 Total % Cover of: _____ Multiply by:
 OBL species _____ x 1 = _____
 FACW species 1 x 2 = 2
 FAC species _____ x 3 = _____
 FACU species _____ x 4 = _____
 UPL species 4 x 5 = 20
 Column Totals: 5 (A) 22 (B)
 Prevalence Index = B/A = 4.4

Hydrophytic Vegetation Indicators:
 Rapid Test for Hydrophytic Vegetation
 Dominance Test is >50%
 Prevalence Index is ≤3.0¹
 Morphological Adaptations¹ (Provide supporting data in Remarks or on a separate sheet)
 Wetland Non-Vascular Plants¹
 Problematic Hydrophytic Vegetation¹ (Explain)

¹Indicators of hydric soil and wetland hydrology must be present, unless disturbed or problematic.

Hydrophytic Vegetation Present? Yes <input type="checkbox"/> No <input checked="" type="checkbox"/>

Remarks: No hydrophytic vegetation indicators observed. Contains <10% vegetation in herb stratum

SOIL

Sampling Point: DP-7

Profile Description: (Describe to the depth needed to document the indicator or confirm the absence of indicators.)								
Depth (inches)	Matrix		Redox Features			Loc ²	Texture	Remarks
	Color (moist)	%	Color (moist)	%	Type ¹			
0-7	10YR 5/3	100	-	-	-	-	SaLo	Sandy loam
7-14	10YR 4/2	95	10YR 4/6	5	C	M	SaLo	Sandy loam; relict redox features
14-20	10YR 5/2	80	7.5YR 5/6	20	C	M	SiLo	Silty loam; relict redox features
¹ Type: C=Concentration, D=Depletion, RM=Reduced Matrix, CS=Covered or Coated Sand Grains. ² Location: PL=Pore Lining, M=Matrix.								
Hydric Soil Indicators: (Applicable to all LRRs, unless otherwise noted.)						Indicators for Problematic Hydric Soils³:		
<input type="checkbox"/> Histosol (A1)			<input type="checkbox"/> Sandy Redox (S5)			<input type="checkbox"/> 2 cm Muck (A10)		
<input type="checkbox"/> Histic Epipedon (A2)			<input type="checkbox"/> Stripped Matrix (S6)			<input type="checkbox"/> Red Parent Material (TF2)		
<input type="checkbox"/> Black Histic (A3)			<input type="checkbox"/> Loamy Mucky Mineral (F1) (except MLRA 1)			<input type="checkbox"/> Very Shallow Dark Surface (TF12)		
<input type="checkbox"/> Hydrogen Sulfide (A4)			<input type="checkbox"/> Loamy Gleyed Matrix (F2)			<input type="checkbox"/> Other (Explain in Remarks)		
<input type="checkbox"/> Depleted Below Dark Surface (A11)			<input type="checkbox"/> Depleted Matrix (F3)			³ Indicators of hydrophytic vegetation and wetland hydrology must be present, unless disturbed or problematic.		
<input type="checkbox"/> Thick Dark Surface (A12)			<input type="checkbox"/> Redox Dark Surface (F6)					
<input type="checkbox"/> Sandy Mucky Mineral (S1)			<input type="checkbox"/> Depleted Dark Surface (F7)					
<input type="checkbox"/> Sandy Gleyed Matrix (S4)			<input type="checkbox"/> Redox Depressions (F8)					
Restrictive Layer (if present):						Hydric Soil Present? Yes <input type="checkbox"/> No <input checked="" type="checkbox"/>		
Type: _____								
Depth (inches): _____								
Remarks: No hydric soil indicators observed. Redox features observed were relict, hard concretions and features along old root channels.								

HYDROLOGY

Wetland Hydrology Indicators:			
Primary Indicators (minimum of one required; check all that apply)		Secondary Indicators (2 or more required)	
<input type="checkbox"/> Surface Water (A1)	<input type="checkbox"/> Water-Stained Leaves (B9) (except MLRA 1, 2, 4A, and 4B)	<input type="checkbox"/> Water-Stained Leaves (B9) (MLRA 1, 2, 4A, and 4B)	
<input type="checkbox"/> High Water Table (A2)	<input type="checkbox"/> Salt Crust (B11)	<input type="checkbox"/> Drainage Patterns (B10)	
<input type="checkbox"/> Saturation (A3)	<input type="checkbox"/> Aquatic Invertebrates (B13)	<input type="checkbox"/> Dry-Season Water Table (C2)	
<input type="checkbox"/> Water Marks (B1)	<input type="checkbox"/> Hydrogen Sulfide Odor (C1)	<input type="checkbox"/> Saturation Visible on Aerial Imagery (C9)	
<input type="checkbox"/> Sediment Deposits (B2)	<input type="checkbox"/> Oxidized Rhizospheres along Living Roots (C3)	<input type="checkbox"/> Geomorphic Position (D2)	
<input type="checkbox"/> Drift Deposits (B3)	<input type="checkbox"/> Presence of Reduced Iron (C4)	<input type="checkbox"/> Shallow Aquitard (D3)	
<input type="checkbox"/> Algal Mat or Crust (B4)	<input type="checkbox"/> Recent Iron Reduction in Tilled Soils (C6)	<input type="checkbox"/> FAC-Neutral Test (D5)	
<input type="checkbox"/> Iron Deposits (B5)	<input type="checkbox"/> Stunted or Stressed Plants (D1) (LRR A)	<input type="checkbox"/> Raised Ant Mounds (D6) (LRR A)	
<input type="checkbox"/> Surface Soil Cracks (B6)	<input type="checkbox"/> Other (Explain in Remarks)	<input type="checkbox"/> Frost-Heave Hummocks (D7)	
<input type="checkbox"/> Inundation Visible on Aerial Imagery (B7)			
<input type="checkbox"/> Sparsely Vegetated Concave Surface (B8)			
Field Observations:		Wetland Hydrology Present? Yes <input type="checkbox"/> No <input checked="" type="checkbox"/>	
Surface Water Present? Yes <input type="checkbox"/> No <input checked="" type="checkbox"/>	Depth (inches): <u>None</u>		
Water Table Present? Yes <input type="checkbox"/> No <input checked="" type="checkbox"/>	Depth (inches): <u>None</u>		
Saturation Present? Yes <input type="checkbox"/> No <input checked="" type="checkbox"/>	Depth (inches): <u>None</u>		
(includes capillary fringe)			
Describe Recorded Data (stream gauge, monitoring well, aerial photos, previous inspections), if available:			
Remarks: No hydrologic indicators observed.			

WETLAND DETERMINATION DATA FORM – Western Mountains, Valleys, and Coast Region

Project/Site: 1649.0001 - Todd Rd. City/County: Puyallup/Pierce Sampling Date: 10/5/2016
 Applicant/Owner: Vector Real Estate Corp. State: WA Sampling Point: DP-8
 Investigator(s): A. Callender / M. DeCaro Section, Township, Range: 21 / 20N / 04E
 Landform (hillslope, terrace, etc.): Valley Local relief (concave, convex, none): None Slope (%): <5
 Subregion (LRR): A2 Lat: 47.212529 Long: -122.298533 Datum: WGS 84
 Soil Map Unit Name: Puyallup Fine Sandy Loam NWI classification: N/A

Are climatic / hydrologic conditions on the site typical for this time of year? Yes No (If no, explain in Remarks.)
 Are Vegetation , Soil , or Hydrology _____ significantly disturbed? Are "Normal Circumstances" present? Yes No
 Are Vegetation _____, Soil _____, or Hydrology _____ naturally problematic? (If needed, explain any answers in Remarks.)

SUMMARY OF FINDINGS – Attach site map showing sampling point locations, transects, important features, etc.

Hydrophytic Vegetation Present? Yes <input type="checkbox"/> No <input checked="" type="checkbox"/> Hydric Soil Present? Yes <input type="checkbox"/> No <input checked="" type="checkbox"/> Wetland Hydrology Present? Yes <input type="checkbox"/> No <input checked="" type="checkbox"/>	Is the Sampled Area within a Wetland? Yes <input type="checkbox"/> No <input checked="" type="checkbox"/>
Remarks: No wetland criteria observed. Recently plowed agricultural field	

VEGETATION – Use scientific names of plants.

<u>Tree Stratum</u> (Plot size: <u>30 ft</u>)	Absolute % Cover	Dominant Species?	Indicator Status	
1. _____	_____	_____	_____	
2. _____	_____	_____	_____	
3. _____	_____	_____	_____	
4. _____	_____	_____	_____	
				0 = Total Cover
<u>Sapling/Shrub Stratum</u> (Plot size: <u>15 ft</u>)				
1. _____	_____	_____	_____	
2. _____	_____	_____	_____	
3. _____	_____	_____	_____	
4. _____	_____	_____	_____	
5. _____	_____	_____	_____	
				0 = Total Cover
<u>Herb Stratum</u> (Plot size: <u>5 ft</u>)				
1. <u>Phalaris arundinacea</u>	5	Yes	FACW	
2. <u>Taraxacum officinale</u>	3	Yes	FACU	
3. <u>Sonchus oleraceus</u>	1	No	UPL	
4. <u>Chenopodium album</u>	1	No	FACU	
5. _____	_____	_____	_____	
6. _____	_____	_____	_____	
7. _____	_____	_____	_____	
8. _____	_____	_____	_____	
9. _____	_____	_____	_____	
10. _____	_____	_____	_____	
11. _____	_____	_____	_____	
				10 = Total Cover
<u>Woody Vine Stratum</u> (Plot size: <u>30 ft</u>)				
1. _____	_____	_____	_____	
2. _____	_____	_____	_____	
				0 = Total Cover
<u>% Bare Ground in Herb Stratum</u> <u>90</u>				

Dominance Test worksheet:
 Number of Dominant Species That Are OBL, FACW, or FAC: 1 (A)
 Total Number of Dominant Species Across All Strata: 2 (B)
 Percent of Dominant Species That Are OBL, FACW, or FAC: 50 (A/B)

Prevalence Index worksheet:
 Total % Cover of: _____ Multiply by:
 OBL species _____ x 1 = _____
 FACW species 5 x 2 = 10
 FAC species _____ x 3 = _____
 FACU species 4 x 4 = 16
 UPL species 1 x 5 = 5
 Column Totals: 10 (A) 31 (B)
 Prevalence Index = B/A = 3.1

Hydrophytic Vegetation Indicators:
 Rapid Test for Hydrophytic Vegetation
 Dominance Test is >50%
 Prevalence Index is ≤3.0¹
 Morphological Adaptations¹ (Provide supporting data in Remarks or on a separate sheet)
 Wetland Non-Vascular Plants¹
 Problematic Hydrophytic Vegetation¹ (Explain)
¹Indicators of hydric soil and wetland hydrology must be present, unless disturbed or problematic.

Hydrophytic Vegetation Present? Yes No

Remarks: No hydrophytic vegetation indicators observed. Contains only 10% vegetation in herb stratum.

SOIL

Sampling Point: DP-8

Profile Description: (Describe to the depth needed to document the indicator or confirm the absence of indicators.)

Depth (inches)	Matrix		Redox Features			Loc ²	Texture	Remarks
	Color (moist)	%	Color (moist)	%	Type ¹			
0-12	10YR 4/3	100	-	-	-	-	SiLo	Silty loam
12-20	10YR 5/2	85	7.5YR 5/6	15	C	M	SiLo	Silty loam; relict redox features

¹Type: C=Concentration, D=Depletion, RM=Reduced Matrix, CS=Covered or Coated Sand Grains. ²Location: PL=Pore Lining, M=Matrix.

Hydric Soil Indicators: (Applicable to all LRRs, unless otherwise noted.)

<input type="checkbox"/> Histosol (A1)	<input type="checkbox"/> Sandy Redox (S5)	Indicators for Problematic Hydric Soils³:
<input type="checkbox"/> Histic Epipedon (A2)	<input type="checkbox"/> Stripped Matrix (S6)	
<input type="checkbox"/> Black Histic (A3)	<input type="checkbox"/> Loamy Mucky Mineral (F1) (except MLRA 1)	
<input type="checkbox"/> Hydrogen Sulfide (A4)	<input type="checkbox"/> Loamy Gleyed Matrix (F2)	
<input type="checkbox"/> Depleted Below Dark Surface (A11)	<input type="checkbox"/> Depleted Matrix (F3)	
<input type="checkbox"/> Thick Dark Surface (A12)	<input type="checkbox"/> Redox Dark Surface (F6)	
<input type="checkbox"/> Sandy Mucky Mineral (S1)	<input type="checkbox"/> Depleted Dark Surface (F7)	
<input type="checkbox"/> Sandy Gleyed Matrix (S4)	<input type="checkbox"/> Redox Depressions (F8)	

2 cm Muck (A10)
 Red Parent Material (TF2)
 Very Shallow Dark Surface (TF12)
 Other (Explain in Remarks)

³Indicators of hydrophytic vegetation and wetland hydrology must be present, unless disturbed or problematic.

Restrictive Layer (if present):
 Type: _____
 Depth (inches): _____

Hydric Soil Present? Yes No

Remarks: No hydric soil indicators observed.

HYDROLOGY

Wetland Hydrology Indicators:

<u>Primary Indicators (minimum of one required; check all that apply)</u>	<u>Secondary Indicators (2 or more required)</u>
<input type="checkbox"/> Surface Water (A1) <input type="checkbox"/> High Water Table (A2) <input type="checkbox"/> Saturation (A3) <input type="checkbox"/> Water Marks (B1) <input type="checkbox"/> Sediment Deposits (B2) <input type="checkbox"/> Drift Deposits (B3) <input type="checkbox"/> Algal Mat or Crust (B4) <input type="checkbox"/> Iron Deposits (B5) <input type="checkbox"/> Surface Soil Cracks (B6) <input type="checkbox"/> Inundation Visible on Aerial Imagery (B7) <input type="checkbox"/> Sparsely Vegetated Concave Surface (B8)	<input type="checkbox"/> Water-Stained Leaves (B9) (except MLRA 1, 2, 4A, and 4B) <input type="checkbox"/> Salt Crust (B11) <input type="checkbox"/> Aquatic Invertebrates (B13) <input type="checkbox"/> Hydrogen Sulfide Odor (C1) <input type="checkbox"/> Oxidized Rhizospheres along Living Roots (C3) <input type="checkbox"/> Presence of Reduced Iron (C4) <input type="checkbox"/> Recent Iron Reduction in Tilled Soils (C6) <input type="checkbox"/> Stunted or Stressed Plants (D1) (LRR A) <input type="checkbox"/> Other (Explain in Remarks)
<input type="checkbox"/> Water-Stained Leaves (B9) (MLRA 1, 2, 4A, and 4B) <input type="checkbox"/> Drainage Patterns (B10) <input type="checkbox"/> Dry-Season Water Table (C2) <input type="checkbox"/> Saturation Visible on Aerial Imagery (C9) <input type="checkbox"/> Geomorphic Position (D2) <input type="checkbox"/> Shallow Aquitard (D3) <input type="checkbox"/> FAC-Neutral Test (D5) <input type="checkbox"/> Raised Ant Mounds (D6) (LRR A) <input type="checkbox"/> Frost-Heave Hummocks (D7)	

Field Observations:

Surface Water Present? Yes <input type="checkbox"/> No <input checked="" type="checkbox"/>	Depth (inches): <u>None</u>	Wetland Hydrology Present? Yes <input type="checkbox"/> No <input checked="" type="checkbox"/>
Water Table Present? Yes <input type="checkbox"/> No <input checked="" type="checkbox"/>	Depth (inches): <u>None</u>	
Saturation Present? Yes <input type="checkbox"/> No <input checked="" type="checkbox"/> (includes capillary fringe)	Depth (inches): <u>None</u>	

Describe Recorded Data (stream gauge, monitoring well, aerial photos, previous inspections), if available:

Remarks: No hydrologic indicators observed.

WETLAND DETERMINATION DATA FORM – Western Mountains, Valleys, and Coast Region

Project/Site: 1649.0001 - Todd Rd. City/County: Puyallup/Pierce Sampling Date: 10/5/2016
 Applicant/Owner: Vector Real Estate Corp. State: WA Sampling Point: DP-9
 Investigator(s): A. Callender / M. DeCaro Section, Township, Range: 21 / 20N / 04E
 Landform (hillslope, terrace, etc.): Valley Local relief (concave, convex, none): None Slope (%): <5
 Subregion (LRR): A2 Lat: 47.212568 Long: -122.298779 Datum: WGS 84
 Soil Map Unit Name: Sultan Silt Loam NWI classification: N/A

Are climatic / hydrologic conditions on the site typical for this time of year? Yes No (If no, explain in Remarks.)
 Are Vegetation , Soil , or Hydrology _____ significantly disturbed? Are "Normal Circumstances" present? Yes No
 Are Vegetation _____, Soil _____, or Hydrology _____ naturally problematic? (If needed, explain any answers in Remarks.)

SUMMARY OF FINDINGS – Attach site map showing sampling point locations, transects, important features, etc.

Hydrophytic Vegetation Present? Yes <input type="checkbox"/> No <input checked="" type="checkbox"/> Hydric Soil Present? Yes <input type="checkbox"/> No <input checked="" type="checkbox"/> Wetland Hydrology Present? Yes <input type="checkbox"/> No <input checked="" type="checkbox"/>	Is the Sampled Area within a Wetland? Yes <input type="checkbox"/> No <input checked="" type="checkbox"/>
Remarks: No wetland criteria observed. Recently plowed agricultural field	

VEGETATION – Use scientific names of plants.

<u>Tree Stratum</u> (Plot size: <u>30 ft</u>)	Absolute % Cover	Dominant Species?	Indicator Status	
1. _____	_____	_____	_____	
2. _____	_____	_____	_____	
3. _____	_____	_____	_____	
4. _____	_____	_____	_____	
				0 _____ = Total Cover
<u>Sapling/Shrub Stratum</u> (Plot size: <u>15 ft</u>)				
1. _____	_____	_____	_____	
2. _____	_____	_____	_____	
3. _____	_____	_____	_____	
4. _____	_____	_____	_____	
5. _____	_____	_____	_____	
				0 _____ = Total Cover
<u>Herb Stratum</u> (Plot size: <u>5 ft</u>)				
1. <u>Taraxacum officinale</u>	1	Yes	FACU	
2. <u>Sonchus oleraceus</u>	1	Yes	UPL	
3. _____	_____	_____	_____	
4. _____	_____	_____	_____	
5. _____	_____	_____	_____	
6. _____	_____	_____	_____	
7. _____	_____	_____	_____	
8. _____	_____	_____	_____	
9. _____	_____	_____	_____	
10. _____	_____	_____	_____	
11. _____	_____	_____	_____	
				2 _____ = Total Cover
<u>Woody Vine Stratum</u> (Plot size: <u>30 ft</u>)				
1. _____	_____	_____	_____	
2. _____	_____	_____	_____	
				0 _____ = Total Cover
<u>% Bare Ground in Herb Stratum</u> <u>98</u>				

Dominance Test worksheet:
 Number of Dominant Species That Are OBL, FACW, or FAC: 0 (A)
 Total Number of Dominant Species Across All Strata: 2 (B)
 Percent of Dominant Species That Are OBL, FACW, or FAC: 0 (A/B)

Prevalence Index worksheet:
 Total % Cover of: _____ Multiply by:
 OBL species _____ x 1 = _____
 FACW species _____ x 2 = _____
 FAC species _____ x 3 = _____
 FACU species _____ x 4 = _____
 UPL species _____ x 5 = _____
 Column Totals: _____ (A) _____ (B)
 Prevalence Index = B/A = _____

Hydrophytic Vegetation Indicators:
 Rapid Test for Hydrophytic Vegetation
 Dominance Test is >50%
 Prevalence Index is ≤3.0¹
 Morphological Adaptations¹ (Provide supporting data in Remarks or on a separate sheet)
 Wetland Non-Vascular Plants¹
 Problematic Hydrophytic Vegetation¹ (Explain)

¹Indicators of hydric soil and wetland hydrology must be present, unless disturbed or problematic.

Hydrophytic Vegetation Present? Yes <input type="checkbox"/> No <input checked="" type="checkbox"/>

Remarks: No hydrophytic vegetation indicators observed. Contains <5% vegetation in herb stratum.

WETLAND DETERMINATION DATA FORM – Western Mountains, Valleys, and Coast Region

Project/Site: 1649.0001 - Todd Rd. City/County: Puyallup/Pierce Sampling Date: 10/5/2016
 Applicant/Owner: Vector Real Estate Corp. State: WA Sampling Point: DP-10
 Investigator(s): A. Callender / M. DeCaro Section, Township, Range: 21 / 20N / 04E
 Landform (hillslope, terrace, etc.): Valley Local relief (concave, convex, none): None Slope (%): <5
 Subregion (LRR): A2 Lat: 47.212811 Long: -122.298752 Datum: WGS 84
 Soil Map Unit Name: Sultan Silt Loam NWI classification: /NA

Are climatic / hydrologic conditions on the site typical for this time of year? Yes No (If no, explain in Remarks.)
 Are Vegetation , Soil , or Hydrology _____ significantly disturbed? Are "Normal Circumstances" present? Yes No
 Are Vegetation _____, Soil _____, or Hydrology _____ naturally problematic? (If needed, explain any answers in Remarks.)

SUMMARY OF FINDINGS – Attach site map showing sampling point locations, transects, important features, etc.

Hydrophytic Vegetation Present? Yes <input checked="" type="checkbox"/> No <input type="checkbox"/> Hydric Soil Present? Yes <input type="checkbox"/> No <input checked="" type="checkbox"/> Wetland Hydrology Present? Yes <input type="checkbox"/> No <input checked="" type="checkbox"/>	Is the Sampled Area within a Wetland? Yes <input type="checkbox"/> No <input checked="" type="checkbox"/>
Remarks: Not all three wetland criteria observed; only hydrophytic vegetation present. Recently plowed agricultural field	

VEGETATION – Use scientific names of plants.

	Absolute % Cover	Dominant Species?	Indicator Status	
Tree Stratum (Plot size: <u>30 ft</u>)				
1. _____	_____	_____	_____	
2. _____	_____	_____	_____	
3. _____	_____	_____	_____	
4. _____	_____	_____	_____	
	<u>0</u>	= Total Cover		
Sapling/Shrub Stratum (Plot size: <u>15 ft</u>)				
1. _____	_____	_____	_____	
2. _____	_____	_____	_____	
3. _____	_____	_____	_____	
4. _____	_____	_____	_____	
5. _____	_____	_____	_____	
	<u>0</u>	= Total Cover		
Herb Stratum (Plot size: <u>5 ft</u>)				
1. <u>Phalaris arundinacea</u>	<u>3</u>	Yes	FACW	
2. <u>Sonchus oleraceus</u>	<u>1</u>	No	UPL	
3. <u>Chenopodium album</u>	<u>1</u>	No	FACU	
4. <u>Persicaria maculosa</u>	<u>1</u>	No	FACW	
5. _____	_____	_____	_____	
6. _____	_____	_____	_____	
7. _____	_____	_____	_____	
8. _____	_____	_____	_____	
9. _____	_____	_____	_____	
10. _____	_____	_____	_____	
11. _____	_____	_____	_____	
	<u>6</u>	= Total Cover		
Woody Vine Stratum (Plot size: <u>30 ft</u>)				
1. _____	_____	_____	_____	
2. _____	_____	_____	_____	
	<u>0</u>	= Total Cover		
% Bare Ground in Herb Stratum <u>94</u>				

Dominance Test worksheet:
 Number of Dominant Species That Are OBL, FACW, or FAC: 1 (A)
 Total Number of Dominant Species Across All Strata: 1 (B)
 Percent of Dominant Species That Are OBL, FACW, or FAC: 100 (A/B)

Prevalence Index worksheet:
 Total % Cover of: _____ Multiply by:
 OBL species _____ x 1 = _____
 FACW species _____ x 2 = _____
 FAC species _____ x 3 = _____
 FACU species _____ x 4 = _____
 UPL species _____ x 5 = _____
 Column Totals: _____ (A) _____ (B)
 Prevalence Index = B/A = _____

Hydrophytic Vegetation Indicators:
 Rapid Test for Hydrophytic Vegetation
 Dominance Test is >50%
 Prevalence Index is ≤3.0¹
 Morphological Adaptations¹ (Provide supporting data in Remarks or on a separate sheet)
 Wetland Non-Vascular Plants¹
 Problematic Hydrophytic Vegetation¹ (Explain)
¹Indicators of hydric soil and wetland hydrology must be present, unless disturbed or problematic.

Hydrophytic Vegetation Present? Yes No

Remarks: Hydrophytic vegetation criteria observed through the dominance test. Contains <10% vegetation cover in herb stratum.

SOIL

Sampling Point: DP-10

Profile Description: (Describe to the depth needed to document the indicator or confirm the absence of indicators.)

Depth (inches)	Matrix		Redox Features			Loc ²	Texture	Remarks
	Color (moist)	%	Color (moist)	%	Type ¹			
0-12	10YR 4/3	100	-	-	-	-	SiLo	Silty loam
12-18	10YR 5/2	70	10YR 5/6	30	C	M	SiLo	Silty loam; relict redox features

¹Type: C=Concentration, D=Depletion, RM=Reduced Matrix, CS=Covered or Coated Sand Grains. ²Location: PL=Pore Lining, M=Matrix.

Hydric Soil Indicators: (Applicable to all LRRs, unless otherwise noted.)

<input type="checkbox"/> Histosol (A1)	<input type="checkbox"/> Sandy Redox (S5)	Indicators for Problematic Hydric Soils³:	
<input type="checkbox"/> Histic Epipedon (A2)	<input type="checkbox"/> Stripped Matrix (S6)		
<input type="checkbox"/> Black Histic (A3)	<input type="checkbox"/> Loamy Mucky Mineral (F1) (except MLRA 1)		
<input type="checkbox"/> Hydrogen Sulfide (A4)	<input type="checkbox"/> Loamy Gleyed Matrix (F2)		
<input type="checkbox"/> Depleted Below Dark Surface (A11)	<input type="checkbox"/> Depleted Matrix (F3)		
<input type="checkbox"/> Thick Dark Surface (A12)	<input type="checkbox"/> Redox Dark Surface (F6)		
<input type="checkbox"/> Sandy Mucky Mineral (S1)	<input type="checkbox"/> Depleted Dark Surface (F7)		
<input type="checkbox"/> Sandy Gleyed Matrix (S4)	<input type="checkbox"/> Redox Depressions (F8)		
			³ Indicators of hydrophytic vegetation and wetland hydrology must be present, unless disturbed or problematic.

Restrictive Layer (if present):
 Type: _____
 Depth (inches): _____

Hydric Soil Present? Yes No

Remarks: No hydric soil indicators observed. Redox features observed were relict, hard concretions.

HYDROLOGY

Wetland Hydrology Indicators:

<u>Primary Indicators (minimum of one required; check all that apply)</u>		<u>Secondary Indicators (2 or more required)</u>
<input type="checkbox"/> Surface Water (A1)	<input type="checkbox"/> Water-Stained Leaves (B9) (except MLRA 1, 2, 4A, and 4B)	<input type="checkbox"/> Water-Stained Leaves (B9) (MLRA 1, 2, 4A, and 4B)
<input type="checkbox"/> High Water Table (A2)	<input type="checkbox"/> Salt Crust (B11)	<input type="checkbox"/> Drainage Patterns (B10)
<input type="checkbox"/> Saturation (A3)	<input type="checkbox"/> Aquatic Invertebrates (B13)	<input type="checkbox"/> Dry-Season Water Table (C2)
<input type="checkbox"/> Water Marks (B1)	<input type="checkbox"/> Hydrogen Sulfide Odor (C1)	<input type="checkbox"/> Saturation Visible on Aerial Imagery (C9)
<input type="checkbox"/> Sediment Deposits (B2)	<input type="checkbox"/> Oxidized Rhizospheres along Living Roots (C3)	<input type="checkbox"/> Geomorphic Position (D2)
<input type="checkbox"/> Drift Deposits (B3)	<input type="checkbox"/> Presence of Reduced Iron (C4)	<input type="checkbox"/> Shallow Aquitard (D3)
<input type="checkbox"/> Algal Mat or Crust (B4)	<input type="checkbox"/> Recent Iron Reduction in Tilled Soils (C6)	<input type="checkbox"/> FAC-Neutral Test (D5)
<input type="checkbox"/> Iron Deposits (B5)	<input type="checkbox"/> Stunted or Stressed Plants (D1) (LRR A)	<input type="checkbox"/> Raised Ant Mounds (D6) (LRR A)
<input type="checkbox"/> Surface Soil Cracks (B6)	<input type="checkbox"/> Other (Explain in Remarks)	<input type="checkbox"/> Frost-Heave Hummocks (D7)
<input type="checkbox"/> Inundation Visible on Aerial Imagery (B7)		
<input type="checkbox"/> Sparsely Vegetated Concave Surface (B8)		

Field Observations:

Surface Water Present?	Yes <input type="checkbox"/> No <input checked="" type="checkbox"/>	Depth (inches): <u>None</u>	Wetland Hydrology Present? Yes <input type="checkbox"/> No <input checked="" type="checkbox"/>
Water Table Present?	Yes <input type="checkbox"/> No <input checked="" type="checkbox"/>	Depth (inches): <u>None</u>	
Saturation Present? (includes capillary fringe)	Yes <input type="checkbox"/> No <input checked="" type="checkbox"/>	Depth (inches): <u>None</u>	
Describe Recorded Data (stream gauge, monitoring well, aerial photos, previous inspections), if available:			

Remarks: No hydrologic indicators observed.

WETLAND DETERMINATION DATA FORM – Western Mountains, Valleys, and Coast Region

Project/Site: 1649.0001 - Todd Rd. City/County: Puyallup/Pierce Sampling Date: 10/5/2016 & 1/5/2023
 Applicant/Owner: Vector Real Estate Corp. State: WA Sampling Point: DP-11
 Investigator(s): A. Callender / M. DeCaro, Kyla Caddey Section, Township, Range: 21 / 20N / 04E
 Kyla Landform (hillslope, terrace, etc.): _____ Local relief (concave, convex, none): None Slope (%): <5
 Valley Subregion (LRR): A2 Lat: 47.213172 Long: -122.298763 Datum: WGS 84
 Soil Map Unit Name: Sultan Silt Loam NWI classification: N/A

Are climatic / hydrologic conditions on the site typical for this time of year? Yes No (If no, explain in Remarks.)
 Are Vegetation , Soil , or Hydrology _____ significantly disturbed? Are "Normal Circumstances" present? Yes No
 Are Vegetation _____, Soil _____, or Hydrology _____ naturally problematic? (If needed, explain any answers in Remarks.)

SUMMARY OF FINDINGS – Attach site map showing sampling point locations, transects, important features, etc.

Hydrophytic Vegetation Present? Yes <input checked="" type="checkbox"/> No <input type="checkbox"/> Hydric Soil Present? Yes <input type="checkbox"/> No <input checked="" type="checkbox"/> Wetland Hydrology Present? Yes <input type="checkbox"/> No <input checked="" type="checkbox"/>	Is the Sampled Area within a Wetland? Yes <input type="checkbox"/> No <input checked="" type="checkbox"/>
Remarks: Not all three wetland criteria observed; only hydrophytic vegetation present. Recently plowed agricultural field	

VEGETATION – Use scientific names of plants.

<u>Tree Stratum</u> (Plot size: <u>30 ft</u>)	<u>Absolute % Cover</u>	<u>Dominant Species?</u>	<u>Indicator Status</u>	
1. _____	_____	_____	_____	
2. _____	_____	_____	_____	
3. _____	_____	_____	_____	
4. _____	_____	_____	_____	
				0 _____ = Total Cover
<u>Sapling/Shrub Stratum</u> (Plot size: <u>15 ft</u>)				
1. _____	_____	_____	_____	
2. _____	_____	_____	_____	
3. _____	_____	_____	_____	
4. _____	_____	_____	_____	
5. _____	_____	_____	_____	
				0 _____ = Total Cover
<u>Herb Stratum</u> (Plot size: <u>5 ft</u>)				
1. <u>Phalaris arundinacea</u>	<u>1</u>	<u>Yes</u>	<u>FACW</u>	
2. _____	_____	_____	_____	
3. _____	_____	_____	_____	
4. _____	_____	_____	_____	
5. _____	_____	_____	_____	
6. _____	_____	_____	_____	
7. _____	_____	_____	_____	
8. _____	_____	_____	_____	
9. _____	_____	_____	_____	
10. _____	_____	_____	_____	
11. _____	_____	_____	_____	
				1 _____ = Total Cover
<u>Woody Vine Stratum</u> (Plot size: <u>30 ft</u>)				
1. _____	_____	_____	_____	
2. _____	_____	_____	_____	
				0 _____ = Total Cover
<u>% Bare Ground in Herb Stratum</u> <u>99</u>				

Dominance Test worksheet:
 Number of Dominant Species That Are OBL, FACW, or FAC: 1 (A)
 Total Number of Dominant Species Across All Strata: 1 (B)
 Percent of Dominant Species That Are OBL, FACW, or FAC: 100 (A/B)

Prevalence Index worksheet:
 Total % Cover of: _____ Multiply by:
 OBL species _____ x 1 = _____
 FACW species _____ x 2 = _____
 FAC species _____ x 3 = _____
 FACU species _____ x 4 = _____
 UPL species _____ x 5 = _____
 Column Totals: _____ (A) _____ (B)
 Prevalence Index = B/A = _____

Hydrophytic Vegetation Indicators:
 Rapid Test for Hydrophytic Vegetation
 Dominance Test is >50%
 Prevalence Index is ≤3.0¹
 Morphological Adaptations¹ (Provide supporting data in Remarks or on a separate sheet)
 Wetland Non-Vascular Plants¹
 Problematic Hydrophytic Vegetation¹ (Explain)
¹Indicators of hydric soil and wetland hydrology must be present, unless disturbed or problematic.

Hydrophytic Vegetation Present? Yes No

Remarks: Hydrophytic vegetation criteria observed through the dominance test. Contains <5% vegetation in herb stratum

SOIL

Sampling Point: DP-11

Profile Description: (Describe to the depth needed to document the indicator or confirm the absence of indicators.)								
Depth (inches)	Matrix		Redox Features			Loc ²	Texture	Remarks
	Color (moist)	%	Color (moist)	%	Type ¹			
0-14	10YR 4/3	100	-	-	-	-	SiLo	Silty loam
14-18	5YR 4/1	100	-	-	-	-	SiLo	Silty loam
18-22	10YR 5/1	70	7.5YR 4/4	30	C	M	SiLo	Silty loam; relict redox features

¹Type: C=Concentration, D=Depletion, RM=Reduced Matrix, CS=Covered or Coated Sand Grains. ²Location: PL=Pore Lining, M=Matrix.

Hydric Soil Indicators: (Applicable to all LRRs, unless otherwise noted.) <input type="checkbox"/> Histosol (A1) <input type="checkbox"/> Histic Epipedon (A2) <input type="checkbox"/> Black Histic (A3) <input type="checkbox"/> Hydrogen Sulfide (A4) <input type="checkbox"/> Depleted Below Dark Surface (A11) <input type="checkbox"/> Thick Dark Surface (A12) <input type="checkbox"/> Sandy Mucky Mineral (S1) <input type="checkbox"/> Sandy Gleyed Matrix (S4)	Indicators for Problematic Hydric Soils³: <input type="checkbox"/> 2 cm Muck (A10) <input type="checkbox"/> Red Parent Material (TF2) <input type="checkbox"/> Very Shallow Dark Surface (TF12) <input type="checkbox"/> Other (Explain in Remarks)
----------------------------------------------------------------------------------------------------------------------------------------------------------------------------------------------------------------------------------------------------------------------------------------------------------------------------------------------------------------------------------------------------------------------------------------------------------------------------------------------------------	-----------------------------------------------------------------------------------------------------------------------------------------------------------------------------------------------------------------------------------------------------------------------------------

³Indicators of hydrophytic vegetation and wetland hydrology must be present, unless disturbed or problematic.

Restrictive Layer (if present): Type: _____ Depth (inches): _____	Hydric Soil Present? Yes <input type="checkbox"/> No <input checked="" type="checkbox"/>
--------------------------------------------------------------------------------	-------------------------------------------------------------------------------------------------

Remarks: No hydric soil indicators observed. Redox features observed were relict, hard concretions.

HYDROLOGY

Wetland Hydrology Indicators:	
Primary Indicators (minimum of one required; check all that apply)	Secondary Indicators (2 or more required)
<input type="checkbox"/> Surface Water (A1) <input type="checkbox"/> High Water Table (A2) <input type="checkbox"/> Saturation (A3) <input type="checkbox"/> Water Marks (B1) <input type="checkbox"/> Sediment Deposits (B2) <input type="checkbox"/> Drift Deposits (B3) <input type="checkbox"/> Algal Mat or Crust (B4) <input type="checkbox"/> Iron Deposits (B5) <input type="checkbox"/> Surface Soil Cracks (B6) <input type="checkbox"/> Inundation Visible on Aerial Imagery (B7) <input type="checkbox"/> Sparsely Vegetated Concave Surface (B8)	<input type="checkbox"/> Water-Stained Leaves (B9) (except MLRA 1, 2, 4A, and 4B) <input type="checkbox"/> Salt Crust (B11) <input type="checkbox"/> Aquatic Invertebrates (B13) <input type="checkbox"/> Hydrogen Sulfide Odor (C1) <input type="checkbox"/> Oxidized Rhizospheres along Living Roots (C3) <input type="checkbox"/> Presence of Reduced Iron (C4) <input type="checkbox"/> Recent Iron Reduction in Tilled Soils (C6) <input type="checkbox"/> Stunted or Stressed Plants (D1) (LRR A) <input type="checkbox"/> Other (Explain in Remarks)
<input type="checkbox"/> Water-Stained Leaves (B9) (MLRA 1, 2, 4A, and 4B) <input type="checkbox"/> Drainage Patterns (B10) <input type="checkbox"/> Dry-Season Water Table (C2) <input type="checkbox"/> Saturation Visible on Aerial Imagery (C9) <input type="checkbox"/> Geomorphic Position (D2) <input type="checkbox"/> Shallow Aquitard (D3) <input type="checkbox"/> FAC-Neutral Test (D5) <input type="checkbox"/> Raised Ant Mounds (D6) (LRR A) <input type="checkbox"/> Frost-Heave Hummocks (D7)	
Field Observations: Surface Water Present? Yes <input type="checkbox"/> No <input checked="" type="checkbox"/> Depth (inches): <u>None</u> Water Table Present? Yes <input type="checkbox"/> No <input checked="" type="checkbox"/> Depth (inches): <u>None</u> Saturation Present? Yes <input type="checkbox"/> No <input checked="" type="checkbox"/> Depth (inches): <u>None</u> (includes capillary fringe)	Wetland Hydrology Present? Yes <input type="checkbox"/> No <input checked="" type="checkbox"/>
Describe Recorded Data (stream gauge, monitoring well, aerial photos, previous inspections), if available:	
Remarks: No hydrologic indicators observed. No evidence of groundwater within 16 inches of the soil surface during revisit on 1/5/2023 under normal wet season hydrologic conditions.	

WETLAND DETERMINATION DATA FORM – Western Mountains, Valleys, and Coast Region

Project/Site: 1649.0001 - Todd Rd. City/County: Puyallup/Pierce Sampling Date: 10/5/2016
 Applicant/Owner: Vector Real Estate Corp. State: WA Sampling Point: DP-12
 Investigator(s): A. Callender / M. DeCaro Section, Township, Range: 21 / 20N / 04E
 Landform (hillslope, terrace, etc.): Valley Local relief (concave, convex, none): None Slope (%): <5
 Subregion (LRR): A2 Lat: 47.213272 Long: -122.298632 Datum: WGS 84
 Soil Map Unit Name: Sultan Silt Loam NWI classification: NA

Are climatic / hydrologic conditions on the site typical for this time of year? Yes No (If no, explain in Remarks.)
 Are Vegetation , Soil , or Hydrology _____ significantly disturbed? Are "Normal Circumstances" present? Yes No
 Are Vegetation _____, Soil _____, or Hydrology _____ naturally problematic? (If needed, explain any answers in Remarks.)

SUMMARY OF FINDINGS – Attach site map showing sampling point locations, transects, important features, etc.

Hydrophytic Vegetation Present? Yes <input checked="" type="checkbox"/> No <input type="checkbox"/> Hydric Soil Present? Yes <input type="checkbox"/> No <input checked="" type="checkbox"/> Wetland Hydrology Present? Yes <input type="checkbox"/> No <input checked="" type="checkbox"/>	Is the Sampled Area within a Wetland? Yes <input type="checkbox"/> No <input checked="" type="checkbox"/>
Remarks: Not all three wetland criteria observed; only hydrophytic vegetation present. Recently plowed agricultural field	

VEGETATION – Use scientific names of plants.

<u>Tree Stratum</u> (Plot size: <u>30 ft</u>)	Absolute % Cover	Dominant Species?	Indicator Status	
1. _____	_____	_____	_____	
2. _____	_____	_____	_____	
3. _____	_____	_____	_____	
4. _____	_____	_____	_____	
	<u>0</u>	= Total Cover		
<u>Sapling/Shrub Stratum</u> (Plot size: <u>15 ft</u>)				
1. _____	_____	_____	_____	
2. _____	_____	_____	_____	
3. _____	_____	_____	_____	
4. _____	_____	_____	_____	
5. _____	_____	_____	_____	
	<u>0</u>	= Total Cover		
<u>Herb Stratum</u> (Plot size: <u>5 ft</u>)				
1. <u>Sonchus oleraceus</u>	<u>1</u>	<u>Yes</u>	<u>UPL</u>	
2. _____	_____	_____	_____	
3. _____	_____	_____	_____	
4. _____	_____	_____	_____	
5. _____	_____	_____	_____	
6. _____	_____	_____	_____	
7. _____	_____	_____	_____	
8. _____	_____	_____	_____	
9. _____	_____	_____	_____	
10. _____	_____	_____	_____	
11. _____	_____	_____	_____	
	<u>1</u>	= Total Cover		
<u>Woody Vine Stratum</u> (Plot size: <u>30 ft</u>)				
1. _____	_____	_____	_____	
2. _____	_____	_____	_____	
	<u>0</u>	= Total Cover		
<u>% Bare Ground in Herb Stratum 99</u>				

Dominance Test worksheet:
 Number of Dominant Species That Are OBL, FACW, or FAC: 1 (A)
 Total Number of Dominant Species Across All Strata: 1 (B)
 Percent of Dominant Species That Are OBL, FACW, or FAC: 100 (A/B)

Prevalence Index worksheet:
 Total % Cover of: _____ Multiply by:
 OBL species _____ x 1 = _____
 FACW species _____ x 2 = _____
 FAC species _____ x 3 = _____
 FACU species _____ x 4 = _____
 UPL species _____ x 5 = _____
 Column Totals: _____ (A) _____ (B)
 Prevalence Index = B/A = _____

Hydrophytic Vegetation Indicators:
 Rapid Test for Hydrophytic Vegetation
 Dominance Test is >50%
 Prevalence Index is ≤3.0¹
 Morphological Adaptations¹ (Provide supporting data in Remarks or on a separate sheet)
 Wetland Non-Vascular Plants¹
 Problematic Hydrophytic Vegetation¹ (Explain)
¹Indicators of hydric soil and wetland hydrology must be present, unless disturbed or problematic.

Hydrophytic Vegetation Present? Yes No

Remarks: Hydrophytic vegetation criteria observed through the dominance test. Contains <5% vegetation in herb stratum

SOIL

Sampling Point: DP-12

Profile Description: (Describe to the depth needed to document the indicator or confirm the absence of indicators.)								
Depth (inches)	Matrix		Redox Features			Loc ²	Texture	Remarks
	Color (moist)	%	Color (moist)	%	Type ¹			
0-12	10YR 4/3	100	-	-	-	-	SiLo	Silty loam
12-22	10YR 4/1	100	-	-	-	-	SiLo	Silty loam

¹Type: C=Concentration, D=Depletion, RM=Reduced Matrix, CS=Covered or Coated Sand Grains. ²Location: PL=Pore Lining, M=Matrix.

Hydric Soil Indicators: (Applicable to all LRRs, unless otherwise noted.)	Indicators for Problematic Hydric Soils ³ :
<input type="checkbox"/> Histosol (A1) <input type="checkbox"/> Histic Epipedon (A2) <input type="checkbox"/> Black Histic (A3) <input type="checkbox"/> Hydrogen Sulfide (A4) <input type="checkbox"/> Depleted Below Dark Surface (A11) <input type="checkbox"/> Thick Dark Surface (A12) <input type="checkbox"/> Sandy Mucky Mineral (S1) <input type="checkbox"/> Sandy Gleyed Matrix (S4)	<input type="checkbox"/> Sandy Redox (S5) <input type="checkbox"/> Stripped Matrix (S6) <input type="checkbox"/> Loamy Mucky Mineral (F1) (except MLRA 1) <input type="checkbox"/> Loamy Gleyed Matrix (F2) <input type="checkbox"/> Depleted Matrix (F3) <input type="checkbox"/> Redox Dark Surface (F6) <input type="checkbox"/> Depleted Dark Surface (F7) <input type="checkbox"/> Redox Depressions (F8)
<input type="checkbox"/> 2 cm Muck (A10) <input type="checkbox"/> Red Parent Material (TF2) <input type="checkbox"/> Very Shallow Dark Surface (TF12) <input type="checkbox"/> Other (Explain in Remarks)	³ Indicators of hydrophytic vegetation and wetland hydrology must be present, unless disturbed or problematic.

Restrictive Layer (if present): Type: _____ Depth (inches): _____	Hydric Soil Present? Yes <input type="checkbox"/> No <input checked="" type="checkbox"/>
--------------------------------------------------------------------------------	-------------------------------------------------------------------------------------------------

Remarks: No hydric soil indicators observed.

HYDROLOGY

Wetland Hydrology Indicators:	
Primary Indicators (minimum of one required; check all that apply)	Secondary Indicators (2 or more required)
<input type="checkbox"/> Surface Water (A1) <input type="checkbox"/> High Water Table (A2) <input type="checkbox"/> Saturation (A3) <input type="checkbox"/> Water Marks (B1) <input type="checkbox"/> Sediment Deposits (B2) <input type="checkbox"/> Drift Deposits (B3) <input type="checkbox"/> Algal Mat or Crust (B4) <input type="checkbox"/> Iron Deposits (B5) <input type="checkbox"/> Surface Soil Cracks (B6) <input type="checkbox"/> Inundation Visible on Aerial Imagery (B7) <input type="checkbox"/> Sparsely Vegetated Concave Surface (B8)	<input type="checkbox"/> Water-Stained Leaves (B9) (except MLRA 1, 2, 4A, and 4B) <input type="checkbox"/> Salt Crust (B11) <input type="checkbox"/> Aquatic Invertebrates (B13) <input type="checkbox"/> Hydrogen Sulfide Odor (C1) <input type="checkbox"/> Oxidized Rhizospheres along Living Roots (C3) <input type="checkbox"/> Presence of Reduced Iron (C4) <input type="checkbox"/> Recent Iron Reduction in Tilled Soils (C6) <input type="checkbox"/> Stunted or Stressed Plants (D1) (LRR A) <input type="checkbox"/> Other (Explain in Remarks)
<input type="checkbox"/> Water-Stained Leaves (B9) (MLRA 1, 2, 4A, and 4B) <input type="checkbox"/> Drainage Patterns (B10) <input type="checkbox"/> Dry-Season Water Table (C2) <input type="checkbox"/> Saturation Visible on Aerial Imagery (C9) <input type="checkbox"/> Geomorphic Position (D2) <input type="checkbox"/> Shallow Aquitard (D3) <input type="checkbox"/> FAC-Neutral Test (D5) <input type="checkbox"/> Raised Ant Mounds (D6) (LRR A) <input type="checkbox"/> Frost-Heave Hummocks (D7)	

Field Observations: Surface Water Present? Yes <input type="checkbox"/> No <input checked="" type="checkbox"/> Depth (inches): <u>None</u> Water Table Present? Yes <input type="checkbox"/> No <input checked="" type="checkbox"/> Depth (inches): <u>None</u> Saturation Present? Yes <input type="checkbox"/> No <input checked="" type="checkbox"/> Depth (inches): <u>None</u> (includes capillary fringe)	Wetland Hydrology Present? Yes <input type="checkbox"/> No <input checked="" type="checkbox"/>
---------------------------------------------------------------------------------------------------------------------------------------------------------------------------------------------------------------------------------------------------------------------------------------------------------------------------------------------------------------------------------------------------------------------------------------------	-------------------------------------------------------------------------------------------------------

Describe Recorded Data (stream gauge, monitoring well, aerial photos, previous inspections), if available:

Remarks: No hydrologic indicators observed.

WETLAND DETERMINATION DATA FORM – Western Mountains, Valleys, and Coast Region

Project/Site: 1649.0001 - Todd Rd. City/County: Puyallup/Pierce Sampling Date: 10/5/2016
 Applicant/Owner: Vector Real Estate Corp. State: WA Sampling Point: DP-13
 Investigator(s): A. Callender / M. DeCaro Section, Township, Range: 21 / 20N / 04E
 Landform (hillslope, terrace, etc.): Valley Local relief (concave, convex, none): None Slope (%): <5
 Subregion (LRR): A2 Lat: 47.213444 Long: -122.298711 Datum: WGS 84
 Soil Map Unit Name: Sultan Silt Loam NWI classification: N/A

Are climatic / hydrologic conditions on the site typical for this time of year? Yes No (If no, explain in Remarks.)
 Are Vegetation , Soil , or Hydrology _____ significantly disturbed? Are "Normal Circumstances" present? Yes No
 Are Vegetation _____, Soil _____, or Hydrology _____ naturally problematic? (If needed, explain any answers in Remarks.)

SUMMARY OF FINDINGS – Attach site map showing sampling point locations, transects, important features, etc.

Hydrophytic Vegetation Present? Yes <input checked="" type="checkbox"/> No <input type="checkbox"/> Hydric Soil Present? Yes <input type="checkbox"/> No <input checked="" type="checkbox"/> Wetland Hydrology Present? Yes <input type="checkbox"/> No <input checked="" type="checkbox"/>	Is the Sampled Area within a Wetland? Yes <input type="checkbox"/> No <input checked="" type="checkbox"/>
Remarks: Not all three wetland criteria observed; only hydrophytic vegetation present. Recently plowed agricultural field	

VEGETATION – Use scientific names of plants.

<u>Tree Stratum</u> (Plot size: <u>30 ft</u>)	Absolute % Cover	Dominant Species?	Indicator Status	
1. _____	_____	_____	_____	Dominance Test worksheet: Number of Dominant Species That Are OBL, FACW, or FAC: <u>3</u> (A) Total Number of Dominant Species Across All Strata: <u>3</u> (B) Percent of Dominant Species That Are OBL, FACW, or FAC: <u>100</u> (A/B)
2. _____	_____	_____	_____	
3. _____	_____	_____	_____	
4. _____	_____	_____	_____	
_____	<u>0</u>	= Total Cover		
<u>Sapling/Shrub Stratum</u> (Plot size: <u>15 ft</u>)				Prevalence Index worksheet: Total % Cover of: _____ Multiply by: OBL species _____ x 1 = _____ FACW species _____ x 2 = _____ FAC species _____ x 3 = _____ FACU species _____ x 4 = _____ UPL species _____ x 5 = _____ Column Totals: _____ (A) _____ (B) Prevalence Index = B/A = _____
1. _____	_____	_____	_____	
2. _____	_____	_____	_____	
3. _____	_____	_____	_____	
4. _____	_____	_____	_____	
5. _____	_____	_____	_____	
_____	<u>0</u>	= Total Cover		
<u>Herb Stratum</u> (Plot size: <u>5 ft</u>)				Hydrophytic Vegetation Indicators: <input type="checkbox"/> Rapid Test for Hydrophytic Vegetation <input checked="" type="checkbox"/> Dominance Test is >50% <input type="checkbox"/> Prevalence Index is ≤3.0 ¹ <input type="checkbox"/> Morphological Adaptations ¹ (Provide supporting data in Remarks or on a separate sheet) <input type="checkbox"/> Wetland Non-Vascular Plants ¹ <input type="checkbox"/> Problematic Hydrophytic Vegetation ¹ (Explain) ¹ Indicators of hydric soil and wetland hydrology must be present, unless disturbed or problematic.
1. <u>Phalaris arundinacea</u>	<u>3</u>	<u>Yes</u>	<u>FACW</u>	
2. <u>Equisetum arvense</u>	<u>1</u>	<u>Yes</u>	<u>FAC</u>	
3. <u>Rumex occidentalis</u>	<u>1</u>	<u>Yes</u>	<u>FACW</u>	
4. _____	_____	_____	_____	
5. _____	_____	_____	_____	
6. _____	_____	_____	_____	
7. _____	_____	_____	_____	
8. _____	_____	_____	_____	
9. _____	_____	_____	_____	
10. _____	_____	_____	_____	
11. _____	_____	_____	_____	
_____	<u>5</u>	= Total Cover		
<u>Woody Vine Stratum</u> (Plot size: <u>30 ft</u>)				Hydrophytic Vegetation Present? Yes <input checked="" type="checkbox"/> No <input type="checkbox"/>
1. _____	_____	_____	_____	
2. _____	_____	_____	_____	
_____	<u>0</u>	= Total Cover		
% Bare Ground in Herb Stratum <u>95</u>				
Remarks: Hydrophytic vegetation criteria observed through the dominance test. Contains <10% vegetation in herb stratum.				

SOIL

Sampling Point: DP-13

Profile Description: (Describe to the depth needed to document the indicator or confirm the absence of indicators.)								
Depth (inches)	Matrix		Redox Features			Loc ²	Texture	Remarks
	Color (moist)	%	Color (moist)	%	Type ¹			
0-6	10YR 4/3	90	2.5YR 3/3	10	C	M	SaLo	Sandy loam; relict redox features
6-12	10YR 4/2	90	7.5YR 4/6	10	C	M	SaLo	Sandy loam; relict redox features
12-18	10YR 5/2	70	7.5YR 5/6	30	C	M	SaLo	Sandy loam; relict redox features
¹ Type: C=Concentration, D=Depletion, RM=Reduced Matrix, CS=Covered or Coated Sand Grains. ² Location: PL=Pore Lining, M=Matrix.								
Hydric Soil Indicators: (Applicable to all LRRs, unless otherwise noted.)						Indicators for Problematic Hydric Soils³:		
<input type="checkbox"/> Histosol (A1)			<input type="checkbox"/> Sandy Redox (S5)			<input type="checkbox"/> 2 cm Muck (A10)		
<input type="checkbox"/> Histic Epipedon (A2)			<input type="checkbox"/> Stripped Matrix (S6)			<input type="checkbox"/> Red Parent Material (TF2)		
<input type="checkbox"/> Black Histic (A3)			<input type="checkbox"/> Loamy Mucky Mineral (F1) (except MLRA 1)			<input type="checkbox"/> Very Shallow Dark Surface (TF12)		
<input type="checkbox"/> Hydrogen Sulfide (A4)			<input type="checkbox"/> Loamy Gleyed Matrix (F2)			<input type="checkbox"/> Other (Explain in Remarks)		
<input type="checkbox"/> Depleted Below Dark Surface (A11)			<input type="checkbox"/> Depleted Matrix (F3)			³ Indicators of hydrophytic vegetation and wetland hydrology must be present, unless disturbed or problematic.		
<input type="checkbox"/> Thick Dark Surface (A12)			<input type="checkbox"/> Redox Dark Surface (F6)					
<input type="checkbox"/> Sandy Mucky Mineral (S1)			<input type="checkbox"/> Depleted Dark Surface (F7)					
<input type="checkbox"/> Sandy Gleyed Matrix (S4)			<input type="checkbox"/> Redox Depressions (F8)					
Restrictive Layer (if present):								
Type: _____ Depth (inches): _____						Hydric Soil Present? Yes <input type="checkbox"/> No <input checked="" type="checkbox"/>		
Remarks: No hydric soil indicators observed. Redox features observed were relict, hard concretions.								

HYDROLOGY

Wetland Hydrology Indicators:			
Primary Indicators (minimum of one required; check all that apply)		Secondary Indicators (2 or more required)	
<input type="checkbox"/> Surface Water (A1)	<input type="checkbox"/> Water-Stained Leaves (B9) (except MLRA 1, 2, 4A, and 4B)	<input type="checkbox"/> Water-Stained Leaves (B9) (MLRA 1, 2, 4A, and 4B)	
<input type="checkbox"/> High Water Table (A2)	<input type="checkbox"/> Salt Crust (B11)	<input type="checkbox"/> Drainage Patterns (B10)	
<input type="checkbox"/> Saturation (A3)	<input type="checkbox"/> Aquatic Invertebrates (B13)	<input type="checkbox"/> Dry-Season Water Table (C2)	
<input type="checkbox"/> Water Marks (B1)	<input type="checkbox"/> Hydrogen Sulfide Odor (C1)	<input type="checkbox"/> Saturation Visible on Aerial Imagery (C9)	
<input type="checkbox"/> Sediment Deposits (B2)	<input type="checkbox"/> Oxidized Rhizospheres along Living Roots (C3)	<input type="checkbox"/> Geomorphic Position (D2)	
<input type="checkbox"/> Drift Deposits (B3)	<input type="checkbox"/> Presence of Reduced Iron (C4)	<input type="checkbox"/> Shallow Aquitard (D3)	
<input type="checkbox"/> Algal Mat or Crust (B4)	<input type="checkbox"/> Recent Iron Reduction in Tilled Soils (C6)	<input type="checkbox"/> FAC-Neutral Test (D5)	
<input type="checkbox"/> Iron Deposits (B5)	<input type="checkbox"/> Stunted or Stressed Plants (D1) (LRR A)	<input type="checkbox"/> Raised Ant Mounds (D6) (LRR A)	
<input type="checkbox"/> Surface Soil Cracks (B6)	<input type="checkbox"/> Other (Explain in Remarks)	<input type="checkbox"/> Frost-Heave Hummocks (D7)	
<input type="checkbox"/> Inundation Visible on Aerial Imagery (B7)			
<input type="checkbox"/> Sparsely Vegetated Concave Surface (B8)			
Field Observations:			
Surface Water Present?	Yes <input type="checkbox"/> No <input checked="" type="checkbox"/>	Depth (inches):	<u>None</u>
Water Table Present?	Yes <input type="checkbox"/> No <input checked="" type="checkbox"/>	Depth (inches):	<u>None</u>
Saturation Present? (includes capillary fringe)	Yes <input type="checkbox"/> No <input checked="" type="checkbox"/>	Depth (inches):	<u>None</u>
		Wetland Hydrology Present? Yes <input type="checkbox"/> No <input checked="" type="checkbox"/>	
Describe Recorded Data (stream gauge, monitoring well, aerial photos, previous inspections), if available:			
Remarks: No hydrologic indicators observed.			

WETLAND DETERMINATION DATA FORM – Western Mountains, Valleys, and Coast Region

Project/Site: 1649.0001 - Todd Rd. City/County: Puyallup / Pierce Sampling Date: 2/14/2018 & 1/5/2023
 Applicant/Owner: Vector Real Estate Corp. State: WA Sampling Point: DP-14
 Investigator(s): Emily Swaim, Richard Peel, Kyla Caddey Section, Township, Range: 21 / 20N / 04E
 Landform (hillslope, terrace, etc.): Valley Floor Local relief (concave, convex, none): None Slope (%): 0
 Subregion (LRR): A2 Lat: 47.213393 Long: -122.29881981 Datum: WGS 84
 Soil Map Unit Name: Sultan Silt Loam NWI classification: N/A

Are climatic / hydrologic conditions on the site typical for this time of year? Yes No (If no, explain in Remarks.)
 Are Vegetation _____, Soil _____, or Hydrology _____ significantly disturbed? Are "Normal Circumstances" present? Yes No
 Are Vegetation _____, Soil _____, or Hydrology _____ naturally problematic? (If needed, explain any answers in Remarks.)

SUMMARY OF FINDINGS – Attach site map showing sampling point locations, transects, important features, etc.

Hydrophytic Vegetation Present? Yes <input checked="" type="checkbox"/> No <input type="checkbox"/> Hydric Soil Present? Yes <input checked="" type="checkbox"/> No <input type="checkbox"/> Wetland Hydrology Present? Yes <input type="checkbox"/> No <input checked="" type="checkbox"/>	Is the Sampled Area within a Wetland? Yes <input type="checkbox"/> No <input checked="" type="checkbox"/>
Remarks: Upland plot to Wetland A. Not all three wetland criteria observed; no wetland hydrology present. Data collected in mowed agricultural field.	

VEGETATION – Use scientific names of plants.

<u>Tree Stratum</u> (Plot size: <u>30 ft</u>)	<u>Absolute % Cover</u>	<u>Dominant Species?</u>	<u>Indicator Status</u>	
1. _____	_____	_____	_____	
2. _____	_____	_____	_____	
3. _____	_____	_____	_____	
4. _____	_____	_____	_____	
				<u>0</u> = Total Cover
<u>Sapling/Shrub Stratum</u> (Plot size: <u>15 ft</u>)				
1. <u>Rubus armeniacus</u>	<u>5</u>	<u>Yes</u>	<u>FAC</u>	
2. _____	_____	_____	_____	
3. _____	_____	_____	_____	
4. _____	_____	_____	_____	
5. _____	_____	_____	_____	
				<u>5</u> = Total Cover
<u>Herb Stratum</u> (Plot size: <u>5 ft</u>)				
1. <u>Ranunculus repens</u>	<u>75</u>	<u>Yes</u>	<u>FAC</u>	
2. <u>Holcus lanatus</u>	<u>20</u>	<u>Yes</u>	<u>FAC</u>	
3. <u>Trifolium repens</u>	<u>5</u>	<u>No</u>	<u>FAC</u>	
4. _____	_____	_____	_____	
5. _____	_____	_____	_____	
6. _____	_____	_____	_____	
7. _____	_____	_____	_____	
8. _____	_____	_____	_____	
9. _____	_____	_____	_____	
10. _____	_____	_____	_____	
11. _____	_____	_____	_____	
				<u>100</u> = Total Cover
<u>Woody Vine Stratum</u> (Plot size: <u>30 ft</u>)				
1. _____	_____	_____	_____	
2. _____	_____	_____	_____	
				<u>0</u> = Total Cover
% Bare Ground in Herb Stratum <u>0</u>				

Dominance Test worksheet:
 Number of Dominant Species That Are OBL, FACW, or FAC: 3 (A)
 Total Number of Dominant Species Across All Strata: 3 (B)
 Percent of Dominant Species That Are OBL, FACW, or FAC: 100% (A/B)

Prevalence Index worksheet:
 Total % Cover of: _____ Multiply by:
 OBL species _____ x 1 = _____
 FACW species _____ x 2 = _____
 FAC species _____ x 3 = _____
 FACU species _____ x 4 = _____
 UPL species _____ x 5 = _____
 Column Totals: _____ (A) _____ (B)
 Prevalence Index = B/A = _____

Hydrophytic Vegetation Indicators:
 Rapid Test for Hydrophytic Vegetation
 Dominance Test is >50%
 Prevalence Index is ≤3.0¹
 Morphological Adaptations¹ (Provide supporting data in Remarks or on a separate sheet)
 Wetland Non-Vascular Plants¹
 Problematic Hydrophytic Vegetation¹ (Explain)
¹Indicators of hydric soil and wetland hydrology must be present, unless disturbed or problematic.

Hydrophytic Vegetation Present? Yes No

Remarks: **Hydrophytic vegetation observed through the dominance test; however, vegetation observed consisted of FAC species typical of disturbed and/or upland fields.**

SOIL

Sampling Point: DP-14

Profile Description: (Describe to the depth needed to document the indicator or confirm the absence of indicators.)								
Depth (inches)	Matrix		Redox Features			Loc ²	Texture	Remarks
	Color (moist)	%	Color (moist)	%	Type ¹			
0 - 4	10YR 3/2	98	5YR 3/4	2	C	PL	SiLo	Silty loam
4 - 11	10YR 3/2	95	5YR 3/4	5	C	M,PL	SiLo	Silty loam
11 - 16+	10YR 5/2	95	7.5YR 4/6	5	C	PL,M	SiLo	Silty loam
¹ Type: C=Concentration, D=Depletion, RM=Reduced Matrix, CS=Covered or Coated Sand Grains. ² Location: PL=Pore Lining, M=Matrix.								
Hydric Soil Indicators: (Applicable to all LRRs, unless otherwise noted.)						Indicators for Problematic Hydric Soils³:		
<input type="checkbox"/> Histosol (A1)			<input type="checkbox"/> Sandy Redox (S5)			<input type="checkbox"/> 2 cm Muck (A10)		
<input type="checkbox"/> Histic Epipedon (A2)			<input type="checkbox"/> Stripped Matrix (S6)			<input type="checkbox"/> Red Parent Material (TF2)		
<input type="checkbox"/> Black Histic (A3)			<input type="checkbox"/> Loamy Mucky Mineral (F1) (except MLRA 1)			<input type="checkbox"/> Very Shallow Dark Surface (TF12)		
<input type="checkbox"/> Hydrogen Sulfide (A4)			<input type="checkbox"/> Loamy Gleyed Matrix (F2)			<input type="checkbox"/> Other (Explain in Remarks)		
<input checked="" type="checkbox"/> Depleted Below Dark Surface (A11)			<input type="checkbox"/> Depleted Matrix (F3)			³ Indicators of hydrophytic vegetation and wetland hydrology must be present, unless disturbed or problematic.		
<input type="checkbox"/> Thick Dark Surface (A12)			<input checked="" type="checkbox"/> Redox Dark Surface (F6)					
<input type="checkbox"/> Sandy Mucky Mineral (S1)			<input type="checkbox"/> Depleted Dark Surface (F7)					
<input type="checkbox"/> Sandy Gleyed Matrix (S4)			<input type="checkbox"/> Redox Depressions (F8)					
Restrictive Layer (if present):						Hydric Soil Present? Yes <input checked="" type="checkbox"/> No <input type="checkbox"/>		
Type: _____ Depth (inches): _____								
Remarks: Hydric soil criteria observed through indicators A11 and F6.								

HYDROLOGY

Wetland Hydrology Indicators:			
Primary Indicators (minimum of one required; check all that apply)		Secondary Indicators (2 or more required)	
<input type="checkbox"/> Surface Water (A1)	<input type="checkbox"/> Water-Stained Leaves (B9) (except MLRA 1, 2, 4A, and 4B)	<input type="checkbox"/> Water-Stained Leaves (B9) (MLRA 1, 2, 4A, and 4B)	
<input type="checkbox"/> High Water Table (A2)	<input type="checkbox"/> Salt Crust (B11)	<input type="checkbox"/> Drainage Patterns (B10)	
<input type="checkbox"/> Saturation (A3)	<input type="checkbox"/> Aquatic Invertebrates (B13)	<input type="checkbox"/> Dry-Season Water Table (C2)	
<input type="checkbox"/> Water Marks (B1)	<input type="checkbox"/> Hydrogen Sulfide Odor (C1)	<input type="checkbox"/> Saturation Visible on Aerial Imagery (C9)	
<input type="checkbox"/> Sediment Deposits (B2)	<input type="checkbox"/> Oxidized Rhizospheres along Living Roots (C3)	<input type="checkbox"/> Geomorphic Position (D2)	
<input type="checkbox"/> Drift Deposits (B3)	<input type="checkbox"/> Presence of Reduced Iron (C4)	<input type="checkbox"/> Shallow Aquitard (D3)	
<input type="checkbox"/> Algal Mat or Crust (B4)	<input type="checkbox"/> Recent Iron Reduction in Tilled Soils (C6)	<input type="checkbox"/> FAC-Neutral Test (D5)	
<input type="checkbox"/> Iron Deposits (B5)	<input type="checkbox"/> Stunted or Stressed Plants (D1) (LRR A)	<input type="checkbox"/> Raised Ant Mounds (D6) (LRR A)	
<input type="checkbox"/> Surface Soil Cracks (B6)	<input type="checkbox"/> Other (Explain in Remarks)	<input type="checkbox"/> Frost-Heave Hummocks (D7)	
<input type="checkbox"/> Inundation Visible on Aerial Imagery (B7)			
<input type="checkbox"/> Sparsely Vegetated Concave Surface (B8)			
Field Observations:		Wetland Hydrology Present? Yes <input type="checkbox"/> No <input checked="" type="checkbox"/>	
Surface Water Present?	Yes <input type="checkbox"/> No <input checked="" type="checkbox"/>	Depth (inches):	<u>None</u>
Water Table Present?	Yes <input checked="" type="checkbox"/> No <input type="checkbox"/>	Depth (inches):	<u>15</u>
Saturation Present? (includes capillary fringe)	Yes <input checked="" type="checkbox"/> No <input type="checkbox"/>	Depth (inches):	<u>13</u>
Describe Recorded Data (stream gauge, monitoring well, aerial photos, previous inspections), if available:			
Remarks: No hydrologic indicators observed. No evidence of groundwater within 16 inches of the soil surface during revisit on 1/5/2023 under normal wet season hydrologic conditions.			

WETLAND DETERMINATION DATA FORM – Western Mountains, Valleys, and Coast Region

Project/Site: 1649.0001 - Todd Rd. City/County: Puyallup / Pierce Sampling Date: 2/14/2018 & 1/5/2023
 Applicant/Owner: Vector Real Estate Corp. State: WA Sampling Point: DP-15
 Investigator(s): Richard Peel, Kyla Caddey Section, Township, Range: 21 / 20N / 04E
 Landform (hillslope, terrace, etc.): Valley Floor Local relief (concave, convex, none): Concave Slope (%): 1
 Subregion (LRR): A2 Lat: 47.213301 Long: -122.29882291 Datum: WGS 84
 Soil Map Unit Name: Sultan Silt Loam NWI classification: N/A

Are climatic / hydrologic conditions on the site typical for this time of year? Yes No (If no, explain in Remarks.)
 Are Vegetation , Soil _____, or Hydrology _____ significantly disturbed? Are "Normal Circumstances" present? Yes No
 Are Vegetation _____, Soil _____, or Hydrology _____ naturally problematic? (If needed, explain any answers in Remarks.)

SUMMARY OF FINDINGS – Attach site map showing sampling point locations, transects, important features, etc.

Hydrophytic Vegetation Present? Yes <input checked="" type="checkbox"/> No <input type="checkbox"/> Hydric Soil Present? Yes <input checked="" type="checkbox"/> No <input type="checkbox"/> Wetland Hydrology Present? Yes <input checked="" type="checkbox"/> No <input type="checkbox"/>	Is the Sampled Area within a Wetland? Yes <input checked="" type="checkbox"/> No <input type="checkbox"/>
Remarks: <p align="center">Wetland A plot. All three wetland criteria were observed. Data collected in mowed agricultural field.</p>	

VEGETATION – Use scientific names of plants.

<u>Tree Stratum</u> (Plot size: <u>30 ft</u>)	<u>Absolute % Cover</u>	<u>Dominant Species?</u>	<u>Indicator Status</u>	
1. _____	_____	_____	_____	
2. _____	_____	_____	_____	
3. _____	_____	_____	_____	
4. _____	_____	_____	_____	
				<u>0</u> = Total Cover
<u>Sapling/Shrub Stratum</u> (Plot size: <u>15 ft</u>)				
1. _____	_____	_____	_____	
2. _____	_____	_____	_____	
3. _____	_____	_____	_____	
4. _____	_____	_____	_____	
5. _____	_____	_____	_____	
				<u>0</u> = Total Cover
<u>Herb Stratum</u> (Plot size: <u>5 ft</u>)				
1. <u>Juncus effusus</u>	<u>30</u>	<u>Yes</u>	<u>FACW</u>	
2. <u>Ranunculus repens</u>	<u>25</u>	<u>Yes</u>	<u>FAC</u>	
3. <u>Holcus lanatus</u>	<u>25</u>	<u>Yes</u>	<u>FAC</u>	
4. <u>Trifolium repens</u>	<u>15</u>	<u>No</u>	<u>FAC</u>	
5. <u>Daucus carota</u>	<u>5</u>	<u>No</u>	<u>FACU</u>	
6. _____	_____	_____	_____	
7. _____	_____	_____	_____	
8. _____	_____	_____	_____	
9. _____	_____	_____	_____	
10. _____	_____	_____	_____	
11. _____	_____	_____	_____	
				<u>100</u> = Total Cover
<u>Woody Vine Stratum</u> (Plot size: <u>30 ft</u>)				
1. _____	_____	_____	_____	
2. _____	_____	_____	_____	
				<u>0</u> = Total Cover
% Bare Ground in Herb Stratum <u>0</u>				

Dominance Test worksheet:
 Number of Dominant Species That Are OBL, FACW, or FAC: 3 (A)
 Total Number of Dominant Species Across All Strata: 3 (B)
 Percent of Dominant Species That Are OBL, FACW, or FAC: 100% (A/B)

Prevalence Index worksheet:
 Total % Cover of: _____ Multiply by: _____
 OBL species _____ x 1 = _____
 FACW species _____ x 2 = _____
 FAC species _____ x 3 = _____
 FACU species _____ x 4 = _____
 UPL species _____ x 5 = _____
 Column Totals: _____ (A) _____ (B)
 Prevalence Index = B/A = _____

Hydrophytic Vegetation Indicators:
 Rapid Test for Hydrophytic Vegetation
 Dominance Test is >50%
 Prevalence Index is ≤3.0¹
 Morphological Adaptations¹ (Provide supporting data in Remarks or on a separate sheet)
 Wetland Non-Vascular Plants¹
 Problematic Hydrophytic Vegetation¹ (Explain)
¹Indicators of hydric soil and wetland hydrology must be present, unless disturbed or problematic.

Remarks: Hydrophytic vegetation criteria observed through the dominance test.	Hydrophytic Vegetation Present? Yes <input checked="" type="checkbox"/> No <input type="checkbox"/>
----------------------------------------------------------------------------------	------------------------------------------------------------------------------------------------------------

SOIL

Sampling Point: DP-15

Profile Description: (Describe to the depth needed to document the indicator or confirm the absence of indicators.)

Depth (inches)	Matrix		Redox Features			Loc ²	Texture	Remarks
	Color (moist)	%	Color (moist)	%	Type ¹			
0 - 8	10YR 4/1	93	7.5YR 4/6	7	C	M,PL	SiLo	Silty loam
8 - 18	10YR 4/1	90	7.5YR 4/6	10	C	M,PL	SiLo	Silty loam

¹Type: C=Concentration, D=Depletion, RM=Reduced Matrix, CS=Covered or Coated Sand Grains. ²Location: PL=Pore Lining, M=Matrix.

Hydric Soil Indicators: (Applicable to all LRRs, unless otherwise noted.)

<input type="checkbox"/> Histosol (A1)	<input type="checkbox"/> Sandy Redox (S5)	Indicators for Problematic Hydric Soils³: <input type="checkbox"/> 2 cm Muck (A10) <input type="checkbox"/> Red Parent Material (TF2) <input type="checkbox"/> Very Shallow Dark Surface (TF12) <input type="checkbox"/> Other (Explain in Remarks)
<input type="checkbox"/> Histic Epipedon (A2)	<input type="checkbox"/> Stripped Matrix (S6)	
<input type="checkbox"/> Black Histic (A3)	<input type="checkbox"/> Loamy Mucky Mineral (F1) (except MLRA 1)	
<input type="checkbox"/> Hydrogen Sulfide (A4)	<input type="checkbox"/> Loamy Gleyed Matrix (F2)	
<input type="checkbox"/> Depleted Below Dark Surface (A11)	<input checked="" type="checkbox"/> Depleted Matrix (F3)	
<input type="checkbox"/> Thick Dark Surface (A12)	<input type="checkbox"/> Redox Dark Surface (F6)	
<input type="checkbox"/> Sandy Mucky Mineral (S1)	<input type="checkbox"/> Depleted Dark Surface (F7)	
<input type="checkbox"/> Sandy Gleyed Matrix (S4)	<input type="checkbox"/> Redox Depressions (F8)	
³ Indicators of hydrophytic vegetation and wetland hydrology must be present, unless disturbed or problematic.		

Restrictive Layer (if present):
Type: _____
Depth (inches): _____

Hydric Soil Present? Yes No

Remarks:
Hydric soil criteria observed through indicator F3.

HYDROLOGY

Wetland Hydrology Indicators:

<u>Primary Indicators (minimum of one required; check all that apply)</u>	<u>Secondary Indicators (2 or more required)</u>
<input type="checkbox"/> Surface Water (A1) <input checked="" type="checkbox"/> High Water Table (A2) <input checked="" type="checkbox"/> Saturation (A3) <input type="checkbox"/> Water Marks (B1) <input type="checkbox"/> Sediment Deposits (B2) <input type="checkbox"/> Drift Deposits (B3) <input type="checkbox"/> Algal Mat or Crust (B4) <input type="checkbox"/> Iron Deposits (B5) <input type="checkbox"/> Surface Soil Cracks (B6) <input type="checkbox"/> Inundation Visible on Aerial Imagery (B7) <input type="checkbox"/> Sparsely Vegetated Concave Surface (B8)	<input type="checkbox"/> Water-Stained Leaves (B9) (except MLRA 1, 2, 4A, and 4B) <input type="checkbox"/> Salt Crust (B11) <input type="checkbox"/> Aquatic Invertebrates (B13) <input type="checkbox"/> Hydrogen Sulfide Odor (C1) <input type="checkbox"/> Oxidized Rhizospheres along Living Roots (C3) <input type="checkbox"/> Presence of Reduced Iron (C4) <input type="checkbox"/> Recent Iron Reduction in Tilled Soils (C6) <input type="checkbox"/> Stunted or Stressed Plants (D1) (LRR A) <input type="checkbox"/> Other (Explain in Remarks)
	<input checked="" type="checkbox"/> Water-Stained Leaves (B9) (MLRA 1, 2, 4A, and 4B) <input checked="" type="checkbox"/> Drainage Patterns (B10) <input type="checkbox"/> Dry-Season Water Table (C2) <input checked="" type="checkbox"/> Saturation Visible on Aerial Imagery (C9) <input checked="" type="checkbox"/> Geomorphic Position (D2) <input type="checkbox"/> Shallow Aquitard (D3) <input type="checkbox"/> FAC-Neutral Test (D5) <input type="checkbox"/> Raised Ant Mounds (D6) (LRR A) <input type="checkbox"/> Frost-Heave Hummocks (D7)

Field Observations:

Surface Water Present? Yes <input type="checkbox"/> No <input checked="" type="checkbox"/>	Depth (inches): <u>None</u>	Wetland Hydrology Present? Yes <input checked="" type="checkbox"/> No <input type="checkbox"/>
Water Table Present? Yes <input checked="" type="checkbox"/> No <input type="checkbox"/>	Depth (inches): <u>7 / 13</u>	
Saturation Present? Yes <input checked="" type="checkbox"/> No <input type="checkbox"/> (includes capillary fringe)	Depth (inches): <u>Surface / 9</u>	

Describe Recorded Data (stream gauge, monitoring well, aerial photos, previous inspections), if available:

Remarks:
Hydrologic criteria observed through primary indicators A2 and A3 and secondary indicators B10, C9, and D2. Water table observed at 13" BGS and saturation at 9" BGS during revisit on 1/5/2023 under normal wet season hydrologic conditions.

WETLAND DETERMINATION DATA FORM – Western Mountains, Valleys, and Coast Region

Project/Site: 1649.0001 - Todd Rd. City/County: Puyallup / Pierce Sampling Date: 2/14/2018 & 1/5/2023
 Applicant/Owner: Vector Real Estate Corp. State: WA Sampling Point: DP-16
 Investigator(s): Richard Peel, Kyla Caddey Section, Township, Range: 21 / 20N / 04E
 Landform (hillslope, terrace, etc.): Valley Floor Local relief (concave, convex, none): Convex Slope (%): 0
 Subregion (LRR): A2 Lat: 47.213244 Long: -122.29870001 Datum: WGS 84
 Soil Map Unit Name: Sultan Silt Loam NWI classification: N/A

Are climatic / hydrologic conditions on the site typical for this time of year? Yes No (If no, explain in Remarks.)
 Are Vegetation , Soil , or Hydrology significantly disturbed? Are "Normal Circumstances" present? Yes No
 Are Vegetation , Soil , or Hydrology naturally problematic? (If needed, explain any answers in Remarks.)

SUMMARY OF FINDINGS – Attach site map showing sampling point locations, transects, important features, etc.

Hydrophytic Vegetation Present? Yes <input checked="" type="checkbox"/> No <input type="checkbox"/> Hydric Soil Present? Yes <input type="checkbox"/> No <input checked="" type="checkbox"/> Wetland Hydrology Present? Yes <input type="checkbox"/> No <input checked="" type="checkbox"/>	Is the Sampled Area within a Wetland? Yes <input type="checkbox"/> No <input checked="" type="checkbox"/>
Remarks: Upland plot to Wetland A. Not all three wetland criteria observed; only hydrophytic vegetation present. Data collected in mowed agricultural field.	

VEGETATION – Use scientific names of plants.

<u>Tree Stratum</u> (Plot size: <u>30 ft</u>)	<u>Absolute % Cover</u>	<u>Dominant Species?</u>	<u>Indicator Status</u>	
1. _____	_____	_____	_____	
2. _____	_____	_____	_____	
3. _____	_____	_____	_____	
4. _____	_____	_____	_____	
				<u>0</u> = Total Cover
<u>Sapling/Shrub Stratum</u> (Plot size: <u>15 ft</u>)				
1. _____	_____	_____	_____	
2. _____	_____	_____	_____	
3. _____	_____	_____	_____	
4. _____	_____	_____	_____	
5. _____	_____	_____	_____	
				<u>0</u> = Total Cover
<u>Herb Stratum</u> (Plot size: <u>5 ft</u>)				
1. <u>Alopecurus pratensis</u>	<u>25</u>	<u>Yes</u>	<u>FAC</u>	
2. <u>Agrostis capillaris</u>	<u>25</u>	<u>Yes</u>	<u>FAC</u>	
3. <u>Holcus lanatus</u>	<u>25</u>	<u>Yes</u>	<u>FAC</u>	
4. <u>Trifolium repens</u>	<u>15</u>	<u>No</u>	<u>FAC</u>	
5. <u>Ranunculus repens</u>	<u>10</u>	<u>No</u>	<u>FAC</u>	
6. _____	_____	_____	_____	
7. _____	_____	_____	_____	
8. _____	_____	_____	_____	
9. _____	_____	_____	_____	
10. _____	_____	_____	_____	
11. _____	_____	_____	_____	
				<u>100</u> = Total Cover
<u>Woody Vine Stratum</u> (Plot size: <u>30 ft</u>)				
1. _____	_____	_____	_____	
2. _____	_____	_____	_____	
				<u>0</u> = Total Cover
% Bare Ground in Herb Stratum <u>0</u>				

Dominance Test worksheet:
 Number of Dominant Species That Are OBL, FACW, or FAC: 3 (A)
 Total Number of Dominant Species Across All Strata: 3 (B)
 Percent of Dominant Species That Are OBL, FACW, or FAC: 100% (A/B)

Prevalence Index worksheet:
 Total % Cover of: _____ Multiply by:
 OBL species _____ x 1 = _____
 FACW species _____ x 2 = _____
 FAC species _____ x 3 = _____
 FACU species _____ x 4 = _____
 UPL species _____ x 5 = _____
 Column Totals: _____ (A) _____ (B)
 Prevalence Index = B/A = _____

Hydrophytic Vegetation Indicators:
 Rapid Test for Hydrophytic Vegetation
 Dominance Test is >50%
 Prevalence Index is ≤3.0¹
 Morphological Adaptations¹ (Provide supporting data in Remarks or on a separate sheet)
 Wetland Non-Vascular Plants¹
 Problematic Hydrophytic Vegetation¹ (Explain)
¹Indicators of hydric soil and wetland hydrology must be present, unless disturbed or problematic.

Remarks: Hydrophytic vegetation observed through the dominance test; however, vegetation observed consisted of FAC species typical of upland fields.	Hydrophytic Vegetation Present? Yes <input checked="" type="checkbox"/> No <input type="checkbox"/>
-------------------------------------------------------------------------------------------------------------------------------------------------------------	------------------------------------------------------------------------------------------------------------

SOIL

Sampling Point: DP-16

Profile Description: (Describe to the depth needed to document the indicator or confirm the absence of indicators.)

Depth (inches)	Matrix		Redox Features			Loc ²	Texture	Remarks
	Color (moist)	%	Color (moist)	%	Type ¹			
0 - 10	10YR 3/2	98	10YR 3/4	2	C	M	SiLo	Silty loam
10 - 16	10YR 3/2	100	-	-	-	-	SiLo	Silty loam

¹Type: C=Concentration, D=Depletion, RM=Reduced Matrix, CS=Covered or Coated Sand Grains. ²Location: PL=Pore Lining, M=Matrix.

Hydric Soil Indicators: (Applicable to all LRRs, unless otherwise noted.)

<input type="checkbox"/> Histosol (A1)	<input type="checkbox"/> Sandy Redox (S5)	Indicators for Problematic Hydric Soils³:
<input type="checkbox"/> Histic Epipedon (A2)	<input type="checkbox"/> Stripped Matrix (S6)	
<input type="checkbox"/> Black Histic (A3)	<input type="checkbox"/> Loamy Mucky Mineral (F1) (except MLRA 1)	
<input type="checkbox"/> Hydrogen Sulfide (A4)	<input type="checkbox"/> Loamy Gleyed Matrix (F2)	
<input type="checkbox"/> Depleted Below Dark Surface (A11)	<input type="checkbox"/> Depleted Matrix (F3)	
<input type="checkbox"/> Thick Dark Surface (A12)	<input type="checkbox"/> Redox Dark Surface (F6)	
<input type="checkbox"/> Sandy Mucky Mineral (S1)	<input type="checkbox"/> Depleted Dark Surface (F7)	
<input type="checkbox"/> Sandy Gleyed Matrix (S4)	<input type="checkbox"/> Redox Depressions (F8)	

2 cm Muck (A10)
 Red Parent Material (TF2)
 Very Shallow Dark Surface (TF12)
 Other (Explain in Remarks)

³Indicators of hydrophytic vegetation and wetland hydrology must be present, unless disturbed or problematic.

Restrictive Layer (if present):
 Type: _____
 Depth (inches): _____

Hydric Soil Present? Yes No

Remarks:
 No hydric soil indicators observed.

HYDROLOGY

Wetland Hydrology Indicators:

<u>Primary Indicators (minimum of one required; check all that apply)</u>	<u>Secondary Indicators (2 or more required)</u>
<input type="checkbox"/> Surface Water (A1) <input type="checkbox"/> High Water Table (A2) <input type="checkbox"/> Saturation (A3) <input type="checkbox"/> Water Marks (B1) <input type="checkbox"/> Sediment Deposits (B2) <input type="checkbox"/> Drift Deposits (B3) <input type="checkbox"/> Algal Mat or Crust (B4) <input type="checkbox"/> Iron Deposits (B5) <input type="checkbox"/> Surface Soil Cracks (B6) <input type="checkbox"/> Inundation Visible on Aerial Imagery (B7) <input type="checkbox"/> Sparsely Vegetated Concave Surface (B8)	<input type="checkbox"/> Water-Stained Leaves (B9) (except MLRA 1, 2, 4A, and 4B) <input type="checkbox"/> Salt Crust (B11) <input type="checkbox"/> Aquatic Invertebrates (B13) <input type="checkbox"/> Hydrogen Sulfide Odor (C1) <input type="checkbox"/> Oxidized Rhizospheres along Living Roots (C3) <input type="checkbox"/> Presence of Reduced Iron (C4) <input type="checkbox"/> Recent Iron Reduction in Tilled Soils (C6) <input type="checkbox"/> Stunted or Stressed Plants (D1) (LRR A) <input type="checkbox"/> Other (Explain in Remarks)
	<input type="checkbox"/> Water-Stained Leaves (B9) (MLRA 1, 2, 4A, and 4B) <input type="checkbox"/> Drainage Patterns (B10) <input type="checkbox"/> Dry-Season Water Table (C2) <input type="checkbox"/> Saturation Visible on Aerial Imagery (C9) <input type="checkbox"/> Geomorphic Position (D2) <input type="checkbox"/> Shallow Aquitard (D3) <input type="checkbox"/> FAC-Neutral Test (D5) <input type="checkbox"/> Raised Ant Mounds (D6) (LRR A) <input type="checkbox"/> Frost-Heave Hummocks (D7)

Field Observations:

Surface Water Present?	Yes <input type="checkbox"/> No <input checked="" type="checkbox"/>	Depth (inches): <u>None</u>	Wetland Hydrology Present? Yes <input type="checkbox"/> No <input checked="" type="checkbox"/>
Water Table Present?	Yes <input type="checkbox"/> No <input checked="" type="checkbox"/>	Depth (inches): <u>None</u>	
Saturation Present? (includes capillary fringe)	Yes <input type="checkbox"/> No <input checked="" type="checkbox"/>	Depth (inches): <u>None</u>	

Describe Recorded Data (stream gauge, monitoring well, aerial photos, previous inspections), if available:

Remarks:
 No hydrologic criteria observed.
 No evidence of groundwater within 16 inches of the soil surface during revisit on 1/5/2023 under normal wet season hydrologic conditions.

WETLAND DETERMINATION DATA FORM – Western Mountains, Valleys, and Coast Region

Project/Site: 1649.0001 - Todd Rd. City/County: Puyallup / Pierce Sampling Date: 02/14/2018
 Applicant/Owner: Vector Real Estate Corp. State: WA Sampling Point: DP-17
 Investigator(s): Emily Swaim, Richard Peel Section, Township, Range: 21 / 20N / 04E
 Landform (hillslope, terrace, etc.): Valley Floor Local relief (concave, convex, none): Concave Slope (%): 0
 Subregion (LRR): A2 Lat: 47.212887 Long: -122.29881423 Datum: WGS 84
 Soil Map Unit Name: Sultan Silt Loam NWI classification: N/A

Are climatic / hydrologic conditions on the site typical for this time of year? Yes No (If no, explain in Remarks.)
 Are Vegetation , Soil _____, or Hydrology _____ significantly disturbed? Are "Normal Circumstances" present? Yes No
 Are Vegetation _____, Soil _____, or Hydrology _____ naturally problematic? (If needed, explain any answers in Remarks.)

SUMMARY OF FINDINGS – Attach site map showing sampling point locations, transects, important features, etc.

Hydrophytic Vegetation Present? Yes <input checked="" type="checkbox"/> No <input type="checkbox"/> Hydric Soil Present? Yes <input checked="" type="checkbox"/> No <input type="checkbox"/> Wetland Hydrology Present? Yes <input type="checkbox"/> No <input checked="" type="checkbox"/>	Is the Sampled Area within a Wetland? Yes <input type="checkbox"/> No <input checked="" type="checkbox"/>
Remarks: Upland plot to Wetland A. Not all three wetland criteria observed. Data collected in mowed agricultural field.	

VEGETATION – Use scientific names of plants.

	Absolute % Cover	Dominant Species?	Indicator Status	
Tree Stratum (Plot size: <u>30 ft</u>)				
1. _____	_____	_____	_____	Dominance Test worksheet: Number of Dominant Species That Are OBL, FACW, or FAC: <u>2</u> (A) Total Number of Dominant Species Across All Strata: <u>3</u> (B) Percent of Dominant Species That Are OBL, FACW, or FAC: <u>67%</u> (A/B)
2. _____	_____	_____	_____	
3. _____	_____	_____	_____	
4. _____	_____	_____	_____	
_____	<u>0</u>	= Total Cover		
Sapling/Shrub Stratum (Plot size: <u>15 ft</u>)				
1. _____	_____	_____	_____	Prevalence Index worksheet: Total % Cover of: _____ Multiply by: OBL species _____ x 1 = _____ FACW species _____ x 2 = _____ FAC species _____ x 3 = _____ FACU species _____ x 4 = _____ UPL species _____ x 5 = _____ Column Totals: _____ (A) _____ (B) Prevalence Index = B/A = _____
2. _____	_____	_____	_____	
3. _____	_____	_____	_____	
4. _____	_____	_____	_____	
5. _____	_____	_____	_____	
Herb Stratum (Plot size: <u>5 ft</u>)				
1. <u>Holcus lanatus</u>	<u>50</u>	<u>Yes</u>	<u>FAC</u>	Hydrophytic Vegetation Indicators: <input type="checkbox"/> Rapid Test for Hydrophytic Vegetation <input checked="" type="checkbox"/> Dominance Test is >50% <input type="checkbox"/> Prevalence Index is ≤3.0 ¹ <input type="checkbox"/> Morphological Adaptations ¹ (Provide supporting data in Remarks or on a separate sheet) <input type="checkbox"/> Wetland Non-Vascular Plants ¹ <input type="checkbox"/> Problematic Hydrophytic Vegetation ¹ (Explain) ¹ Indicators of hydric soil and wetland hydrology must be present, unless disturbed or problematic.
2. <u>Trifolium pratense</u>	<u>30</u>	<u>Yes</u>	<u>FACU</u>	
3. <u>Ranunculus repens</u>	<u>20</u>	<u>Yes</u>	<u>FAC</u>	
4. _____	_____	_____	_____	
5. _____	_____	_____	_____	
6. _____	_____	_____	_____	
7. _____	_____	_____	_____	
8. _____	_____	_____	_____	
9. _____	_____	_____	_____	
10. _____	_____	_____	_____	
11. _____	_____	_____	_____	
Woody Vine Stratum (Plot size: <u>30 ft</u>)				
1. _____	_____	_____	_____	Hydrophytic Vegetation Present? Yes <input checked="" type="checkbox"/> No <input type="checkbox"/>
2. _____	_____	_____	_____	
% Bare Ground in Herb Stratum <u>0</u>				
_____ = Total Cover				

Remarks: **Hydrophytic vegetation observed through dominance test; however, vegetation observed consisted of FAC-FACU species typical of upland fields.**

SOIL

Sampling Point: DP-17

Profile Description: (Describe to the depth needed to document the indicator or confirm the absence of indicators.)								
Depth (inches)	Matrix		Redox Features			Loc ²	Texture	Remarks
	Color (moist)	%	Color (moist)	%	Type ¹			
0 - 4	10YR 3/2	99	7.5YR 3/4	1	C	M,PL	SiLo	Silty loam
4 - 14	10YR 3/2	93	7.5YR 3/4	7	C	M,PL	SiLo	Silty loam
14 - 16	10YR 5/1	97	7.5YR 5/6	3	C	PL,M	SiCl	Silty clay
¹ Type: C=Concentration, D=Depletion, RM=Reduced Matrix, CS=Covered or Coated Sand Grains. ² Location: PL=Pore Lining, M=Matrix.								
Hydric Soil Indicators: (Applicable to all LRRs, unless otherwise noted.)						Indicators for Problematic Hydric Soils³:		
<input type="checkbox"/> Histosol (A1)			<input type="checkbox"/> Sandy Redox (S5)			<input type="checkbox"/> 2 cm Muck (A10)		
<input type="checkbox"/> Histic Epipedon (A2)			<input type="checkbox"/> Stripped Matrix (S6)			<input type="checkbox"/> Red Parent Material (TF2)		
<input type="checkbox"/> Black Histic (A3)			<input type="checkbox"/> Loamy Mucky Mineral (F1) (except MLRA 1)			<input type="checkbox"/> Very Shallow Dark Surface (TF12)		
<input type="checkbox"/> Hydrogen Sulfide (A4)			<input type="checkbox"/> Loamy Gleyed Matrix (F2)			<input type="checkbox"/> Other (Explain in Remarks)		
<input type="checkbox"/> Depleted Below Dark Surface (A11)			<input type="checkbox"/> Depleted Matrix (F3)			³ Indicators of hydrophytic vegetation and wetland hydrology must be present, unless disturbed or problematic.		
<input type="checkbox"/> Thick Dark Surface (A12)			<input checked="" type="checkbox"/> Redox Dark Surface (F6)					
<input type="checkbox"/> Sandy Mucky Mineral (S1)			<input type="checkbox"/> Depleted Dark Surface (F7)					
<input type="checkbox"/> Sandy Gleyed Matrix (S4)			<input type="checkbox"/> Redox Depressions (F8)					
Restrictive Layer (if present):						Hydric Soil Present? Yes <input checked="" type="checkbox"/> No <input type="checkbox"/>		
Type: _____ Depth (inches): _____								
Remarks: Hydric soil criteria observed through indicator F6.								

HYDROLOGY

Wetland Hydrology Indicators:			
Primary Indicators (minimum of one required; check all that apply)		Secondary Indicators (2 or more required)	
<input type="checkbox"/> Surface Water (A1)	<input type="checkbox"/> Water-Stained Leaves (B9) (except MLRA 1, 2, 4A, and 4B)	<input type="checkbox"/> Water-Stained Leaves (B9) (MLRA 1, 2, 4A, and 4B)	
<input type="checkbox"/> High Water Table (A2)	<input type="checkbox"/> Salt Crust (B11)	<input type="checkbox"/> Drainage Patterns (B10)	
<input type="checkbox"/> Saturation (A3)	<input type="checkbox"/> Aquatic Invertebrates (B13)	<input type="checkbox"/> Dry-Season Water Table (C2)	
<input type="checkbox"/> Water Marks (B1)	<input type="checkbox"/> Hydrogen Sulfide Odor (C1)	<input type="checkbox"/> Saturation Visible on Aerial Imagery (C9)	
<input type="checkbox"/> Sediment Deposits (B2)	<input type="checkbox"/> Oxidized Rhizospheres along Living Roots (C3)	<input type="checkbox"/> Geomorphic Position (D2)	
<input type="checkbox"/> Drift Deposits (B3)	<input type="checkbox"/> Presence of Reduced Iron (C4)	<input type="checkbox"/> Shallow Aquitard (D3)	
<input type="checkbox"/> Algal Mat or Crust (B4)	<input type="checkbox"/> Recent Iron Reduction in Tilled Soils (C6)	<input type="checkbox"/> FAC-Neutral Test (D5)	
<input type="checkbox"/> Iron Deposits (B5)	<input type="checkbox"/> Stunted or Stressed Plants (D1) (LRR A)	<input type="checkbox"/> Raised Ant Mounds (D6) (LRR A)	
<input type="checkbox"/> Surface Soil Cracks (B6)	<input type="checkbox"/> Other (Explain in Remarks)	<input type="checkbox"/> Frost-Heave Hummocks (D7)	
<input type="checkbox"/> Inundation Visible on Aerial Imagery (B7)			
<input type="checkbox"/> Sparsely Vegetated Concave Surface (B8)			
Field Observations:		Wetland Hydrology Present? Yes <input type="checkbox"/> No <input checked="" type="checkbox"/>	
Surface Water Present?	Yes <input type="checkbox"/> No <input checked="" type="checkbox"/>	Depth (inches):	<u>None</u>
Water Table Present?	Yes <input checked="" type="checkbox"/> No <input type="checkbox"/>	Depth (inches):	<u>15</u>
Saturation Present? (includes capillary fringe)	Yes <input checked="" type="checkbox"/> No <input type="checkbox"/>	Depth (inches):	<u>13</u>
Describe Recorded Data (stream gauge, monitoring well, aerial photos, previous inspections), if available:			
Remarks: No hydrologic indicators observed.			

WETLAND DETERMINATION DATA FORM – Western Mountains, Valleys, and Coast Region

Project/Site: 1649.0001 - Todd Rd. City/County: Puyallup / Pierce Sampling Date: 02/14/2018
 Applicant/Owner: Vector Real Estate Corp. State: WA Sampling Point: DP-18
 Investigator(s): Emily Swaim, Richard Peel Section, Township, Range: 21 / 20N / 04E
 Landform (hillslope, terrace, etc.): Valley Floor Local relief (concave, convex, none): None Slope (%): 0
 Subregion (LRR): A2 Lat: 47.213243 Long: -122.29810953 Datum: WGS 84
 Soil Map Unit Name: Puyallup Fine Sandy Loam NWI classification: N/A

Are climatic / hydrologic conditions on the site typical for this time of year? Yes No (If no, explain in Remarks.)
 Are Vegetation , Soil , or Hydrology significantly disturbed? Are "Normal Circumstances" present? Yes No
 Are Vegetation , Soil , or Hydrology naturally problematic? (If needed, explain any answers in Remarks.)

SUMMARY OF FINDINGS – Attach site map showing sampling point locations, transects, important features, etc.

Hydrophytic Vegetation Present? Yes <input checked="" type="checkbox"/> No <input type="checkbox"/> Hydric Soil Present? Yes <input type="checkbox"/> No <input checked="" type="checkbox"/> Wetland Hydrology Present? Yes <input type="checkbox"/> No <input checked="" type="checkbox"/>	Is the Sampled Area within a Wetland? Yes <input type="checkbox"/> No <input checked="" type="checkbox"/>
Remarks: Not all three wetland criteria were observed; only hydrophytic vegetation present. Data collected in mowed agricultural field.	

VEGETATION – Use scientific names of plants.

<u>Tree Stratum</u> (Plot size: <u>30 ft</u>)	<u>Absolute % Cover</u>	<u>Dominant Species?</u>	<u>Indicator Status</u>	
1. _____	_____	_____	_____	
2. _____	_____	_____	_____	
3. _____	_____	_____	_____	
4. _____	_____	_____	_____	
				<u>0</u> = Total Cover
<u>Sapling/Shrub Stratum</u> (Plot size: <u>15 ft</u>)				
1. _____	_____	_____	_____	
2. _____	_____	_____	_____	
3. _____	_____	_____	_____	
4. _____	_____	_____	_____	
5. _____	_____	_____	_____	
				<u>0</u> = Total Cover
<u>Herb Stratum</u> (Plot size: <u>5 ft</u>)				
1. <u>Holcus lanatus</u>	<u>35</u>	<u>Yes</u>	<u>FAC</u>	
2. <u>Trifolium repens</u>	<u>30</u>	<u>Yes</u>	<u>FAC</u>	
3. <u>Agrostis capillaris</u>	<u>20</u>	<u>Yes</u>	<u>FAC</u>	
4. <u>Ranunculus repens</u>	<u>15</u>	<u>No</u>	<u>FAC</u>	
5. _____	_____	_____	_____	
6. _____	_____	_____	_____	
7. _____	_____	_____	_____	
8. _____	_____	_____	_____	
9. _____	_____	_____	_____	
10. _____	_____	_____	_____	
11. _____	_____	_____	_____	
				<u>100</u> = Total Cover
<u>Woody Vine Stratum</u> (Plot size: <u>30 ft</u>)				
1. _____	_____	_____	_____	
2. _____	_____	_____	_____	
				<u>0</u> = Total Cover
% Bare Ground in Herb Stratum <u>0</u>				

Dominance Test worksheet:
 Number of Dominant Species That Are OBL, FACW, or FAC: 3 (A)
 Total Number of Dominant Species Across All Strata: 3 (B)
 Percent of Dominant Species That Are OBL, FACW, or FAC: 100% (A/B)

Prevalence Index worksheet:
 Total % Cover of: _____ Multiply by:
 OBL species _____ x 1 = _____
 FACW species _____ x 2 = _____
 FAC species _____ x 3 = _____
 FACU species _____ x 4 = _____
 UPL species _____ x 5 = _____
 Column Totals: _____ (A) _____ (B)
 Prevalence Index = B/A = _____

Hydrophytic Vegetation Indicators:
 Rapid Test for Hydrophytic Vegetation
 Dominance Test is >50%
 Prevalence Index is ≤3.0¹
 Morphological Adaptations¹ (Provide supporting data in Remarks or on a separate sheet)
 Wetland Non-Vascular Plants¹
 Problematic Hydrophytic Vegetation¹ (Explain)
¹Indicators of hydric soil and wetland hydrology must be present, unless disturbed or problematic.

Hydrophytic Vegetation Present? Yes No

Remarks: **Hydrophytic vegetation observed through the dominance test; however, vegetation observed consisted of FAC species typical of upland fields.**

WETLAND DETERMINATION DATA FORM – Western Mountains, Valleys, and Coast Region

Project/Site: 1649.0001 - Todd Rd. City/County: Puyallup / Pierce Sampling Date: 02/14/2018
 Applicant/Owner: Vector Real Estate Corp. State: WA Sampling Point: DP-19
 Investigator(s): Emily Swaim, Richard Peel Section, Township, Range: 21 / 20N / 04E
 Landform (hillslope, terrace, etc.): Valley Floor Local relief (concave, convex, none): Concave Slope (%): 0
 Subregion (LRR): A2 Lat: 47.213576 Long: -122.29878344 Datum: WGS 84
 Soil Map Unit Name: Sultan Silt Loam NWI classification: N/A

Are climatic / hydrologic conditions on the site typical for this time of year? Yes No (If no, explain in Remarks.)
 Are Vegetation , Soil , or Hydrology significantly disturbed? Are "Normal Circumstances" present? Yes No
 Are Vegetation , Soil , or Hydrology naturally problematic? (If needed, explain any answers in Remarks.)

SUMMARY OF FINDINGS – Attach site map showing sampling point locations, transects, important features, etc.

Hydrophytic Vegetation Present? Yes <input checked="" type="checkbox"/> No <input type="checkbox"/> Hydric Soil Present? Yes <input type="checkbox"/> No <input checked="" type="checkbox"/> Wetland Hydrology Present? Yes <input type="checkbox"/> No <input checked="" type="checkbox"/>	Is the Sampled Area within a Wetland? Yes <input type="checkbox"/> No <input checked="" type="checkbox"/>
Remarks: Not all three wetland criteria observed; only hydrophytic vegetation present. Data collected in mowed agricultural field.	

VEGETATION – Use scientific names of plants.

<u>Tree Stratum</u> (Plot size: <u>30 ft</u>)	Absolute % Cover	Dominant Species?	Indicator Status	
1. _____	_____	_____	_____	
2. _____	_____	_____	_____	
3. _____	_____	_____	_____	
4. _____	_____	_____	_____	
				<u>0</u> = Total Cover
<u>Sapling/Shrub Stratum</u> (Plot size: <u>15 ft</u>)				
1. _____	_____	_____	_____	
2. _____	_____	_____	_____	
3. _____	_____	_____	_____	
4. _____	_____	_____	_____	
5. _____	_____	_____	_____	
				<u>0</u> = Total Cover
<u>Herb Stratum</u> (Plot size: <u>5 ft</u>)				
1. <u>Trifolium repens</u>	<u>60</u>	<u>Yes</u>	<u>FAC</u>	
2. <u>Ranunculus repens</u>	<u>40</u>	<u>Yes</u>	<u>FAC</u>	
3. _____	_____	_____	_____	
4. _____	_____	_____	_____	
5. _____	_____	_____	_____	
6. _____	_____	_____	_____	
7. _____	_____	_____	_____	
8. _____	_____	_____	_____	
9. _____	_____	_____	_____	
10. _____	_____	_____	_____	
11. _____	_____	_____	_____	
				<u>100</u> = Total Cover
<u>Woody Vine Stratum</u> (Plot size: <u>30 ft</u>)				
1. _____	_____	_____	_____	
2. _____	_____	_____	_____	
				<u>0</u> = Total Cover
% Bare Ground in Herb Stratum <u>0</u>				

Dominance Test worksheet:
 Number of Dominant Species That Are OBL, FACW, or FAC: 2 (A)
 Total Number of Dominant Species Across All Strata: 2 (B)
 Percent of Dominant Species That Are OBL, FACW, or FAC: 100% (A/B)

Prevalence Index worksheet:
 Total % Cover of: _____ Multiply by:
 OBL species _____ x 1 = _____
 FACW species _____ x 2 = _____
 FAC species _____ x 3 = _____
 FACU species _____ x 4 = _____
 UPL species _____ x 5 = _____
 Column Totals: _____ (A) _____ (B)
 Prevalence Index = B/A = _____

Hydrophytic Vegetation Indicators:
 Rapid Test for Hydrophytic Vegetation
 Dominance Test is >50%
 Prevalence Index is ≤3.0¹
 Morphological Adaptations¹ (Provide supporting data in Remarks or on a separate sheet)
 Wetland Non-Vascular Plants¹
 Problematic Hydrophytic Vegetation¹ (Explain)
¹Indicators of hydric soil and wetland hydrology must be present, unless disturbed or problematic.

Hydrophytic Vegetation Present? Yes No

Remarks: **Hydrophytic vegetation observed through the dominance test; however, vegetation observed consisted of FAC species typical of upland fields..**

SOIL

Sampling Point: DP-19

Profile Description: (Describe to the depth needed to document the indicator or confirm the absence of indicators.)

Depth (inches)	Matrix		Redox Features			Loc ²	Texture	Remarks
	Color (moist)	%	Color (moist)	%	Type ¹			
0 - 8	10YR 3/2	100	-	-	-	-	SiLo	Silty loam
8 - 15	10YR 3/2	98	10YR 3/4	2	C	PL,M	SiLo	Silty loam
15 - 18	10YR 4/2	97	7.5YR 4/6	3	C	PL,M	Silt	

¹Type: C=Concentration, D=Depletion, RM=Reduced Matrix, CS=Covered or Coated Sand Grains. ²Location: PL=Pore Lining, M=Matrix.

Hydric Soil Indicators: (Applicable to all LRRs, unless otherwise noted.)

<input type="checkbox"/> Histosol (A1)	<input type="checkbox"/> Sandy Redox (S5)	Indicators for Problematic Hydric Soils³: <input type="checkbox"/> 2 cm Muck (A10) <input type="checkbox"/> Red Parent Material (TF2) <input type="checkbox"/> Very Shallow Dark Surface (TF12) <input type="checkbox"/> Other (Explain in Remarks) ³ Indicators of hydrophytic vegetation and wetland hydrology must be present, unless disturbed or problematic.
<input type="checkbox"/> Histic Epipedon (A2)	<input type="checkbox"/> Stripped Matrix (S6)	
<input type="checkbox"/> Black Histic (A3)	<input type="checkbox"/> Loamy Mucky Mineral (F1) (except MLRA 1)	
<input type="checkbox"/> Hydrogen Sulfide (A4)	<input type="checkbox"/> Loamy Gleyed Matrix (F2)	
<input type="checkbox"/> Depleted Below Dark Surface (A11)	<input type="checkbox"/> Depleted Matrix (F3)	
<input type="checkbox"/> Thick Dark Surface (A12)	<input type="checkbox"/> Redox Dark Surface (F6)	
<input type="checkbox"/> Sandy Mucky Mineral (S1)	<input type="checkbox"/> Depleted Dark Surface (F7)	
<input type="checkbox"/> Sandy Gleyed Matrix (S4)	<input type="checkbox"/> Redox Depressions (F8)	

Restrictive Layer (if present):
 Type: _____
 Depth (inches): _____

Hydric Soil Present? Yes No

Remarks:
 No hydric soil indicators observed.

HYDROLOGY

Wetland Hydrology Indicators:

Primary Indicators (minimum of one required; check all that apply)	Secondary Indicators (2 or more required)
<input type="checkbox"/> Surface Water (A1) <input type="checkbox"/> High Water Table (A2) <input type="checkbox"/> Saturation (A3) <input type="checkbox"/> Water Marks (B1) <input type="checkbox"/> Sediment Deposits (B2) <input type="checkbox"/> Drift Deposits (B3) <input type="checkbox"/> Algal Mat or Crust (B4) <input type="checkbox"/> Iron Deposits (B5) <input type="checkbox"/> Surface Soil Cracks (B6) <input type="checkbox"/> Inundation Visible on Aerial Imagery (B7) <input type="checkbox"/> Sparsely Vegetated Concave Surface (B8)	<input type="checkbox"/> Water-Stained Leaves (B9) (except MLRA 1, 2, 4A, and 4B) <input type="checkbox"/> Salt Crust (B11) <input type="checkbox"/> Aquatic Invertebrates (B13) <input type="checkbox"/> Hydrogen Sulfide Odor (C1) <input type="checkbox"/> Oxidized Rhizospheres along Living Roots (C3) <input type="checkbox"/> Presence of Reduced Iron (C4) <input type="checkbox"/> Recent Iron Reduction in Tilled Soils (C6) <input type="checkbox"/> Stunted or Stressed Plants (D1) (LRR A) <input type="checkbox"/> Other (Explain in Remarks)
	<input type="checkbox"/> Water-Stained Leaves (B9) (MLRA 1, 2, 4A, and 4B) <input type="checkbox"/> Drainage Patterns (B10) <input type="checkbox"/> Dry-Season Water Table (C2) <input type="checkbox"/> Saturation Visible on Aerial Imagery (C9) <input type="checkbox"/> Geomorphic Position (D2) <input type="checkbox"/> Shallow Aquitard (D3) <input type="checkbox"/> FAC-Neutral Test (D5) <input type="checkbox"/> Raised Ant Mounds (D6) (LRR A) <input type="checkbox"/> Frost-Heave Hummocks (D7)

Field Observations:

Surface Water Present?	Yes <input type="checkbox"/> No <input checked="" type="checkbox"/>	Depth (inches): <u>None</u>	Wetland Hydrology Present? Yes <input type="checkbox"/> No <input checked="" type="checkbox"/>
Water Table Present?	Yes <input type="checkbox"/> No <input checked="" type="checkbox"/>	Depth (inches): <u>None</u>	
Saturation Present? (includes capillary fringe)	Yes <input type="checkbox"/> No <input checked="" type="checkbox"/>	Depth (inches): <u>None</u>	

Describe Recorded Data (stream gauge, monitoring well, aerial photos, previous inspections), if available:

Remarks:
 No hydrologic indicators observed.

Appendix E – Wetland Rating Forms

Wetland name or number A

RATING SUMMARY – Western Washington

Name of wetland (or ID #): A Date of site visit: 2/14/18 & 1/5/23
 Rated by Richard Peel, Emily Swaim, Kyla Caddey Trained by Ecology? Yes No Date of training 3/2016 & 10/2016
 HGM Class used for rating Depressional Wetland has multiple HGM classes? Y N

NOTE: Form is not complete without the figures requested (figures can be combined).
 Source of base aerial photo/map ESRI ArcGIS

OVERALL WETLAND CATEGORY IV (based on functions or special characteristics)

1. Category of wetland based on FUNCTIONS

- Category I** – Total score = 23 - 27
- Category II** – Total score = 20 - 22
- Category III** – Total score = 16 - 19
- Category IV** – Total score = 9 - 15

FUNCTION	Improving Water Quality	Hydrologic	Habitat	
<i>Circle the appropriate ratings</i>				
Site Potential	L	L	L	
Landscape Potential	M	M	L	
Value	H	M	L	TOTAL
Score Based on Ratings	6	5	3	14

Score for each function based on three ratings (order of ratings is not important)

- 9 = H,H,H
- 8 = H,H,M
- 7 = H,H,L
- 7 = H,M,M
- 6 = H,M,L
- 6 = M,M,M
- 5 = H,L,L
- 5 = M,M,L
- 4 = M,L,L
- 3 = L,L,L

2. Category based on SPECIAL CHARACTERISTICS of wetland

CHARACTERISTIC	CATEGORY
Estuarine	I II
Wetland of High Conservation Value	I
Bog	I
Mature Forest	I
Old Growth Forest	I
Coastal Lagoon	I II
Interdunal	I II III IV
None of the above	N/A

Wetland name or number A

Maps and figures required to answer questions correctly for Western Washington

Depressional Wetlands

Map of:	To answer questions:	Figure #
Cowardin plant classes	D 1.3, H 1.1, H 1.4	
Hydroperiods	D 1.4, H 1.2	
Location of outlet (<i>can be added to map of hydroperiods</i>)	D 1.1, D 4.1	
Boundary of area within 150 ft of the wetland (<i>can be added to another figure</i>)	D 2.2, D 5.2	
Map of the contributing basin	D 4.3, D 5.3	
1 km Polygon: Area that extends 1 km from entire wetland edge - including polygons for accessible habitat and undisturbed habitat	H 2.1, H 2.2, H 2.3	
Screen capture of map of 303(d) listed waters in basin (from Ecology website)	D 3.1, D 3.2	
Screen capture of list of TMDLs for WRIA in which unit is found (from web)	D 3.3	

Riverine Wetlands

Map of:	To answer questions:	Figure #
Cowardin plant classes	H 1.1, H 1.4	
Hydroperiods	H 1.2	
Ponded depressions	R 1.1	
Boundary of area within 150 ft of the wetland (<i>can be added to another figure</i>)	R 2.4	
Plant cover of trees, shrubs, and herbaceous plants	R 1.2, R 4.2	
Width of unit vs. width of stream (<i>can be added to another figure</i>)	R 4.1	
Map of the contributing basin	R 2.2, R 2.3, R 5.2	
1 km Polygon: Area that extends 1 km from entire wetland edge - including polygons for accessible habitat and undisturbed habitat	H 2.1, H 2.2, H 2.3	
Screen capture of map of 303(d) listed waters in basin (from Ecology website)	R 3.1	
Screen capture of list of TMDLs for WRIA in which unit is found (from web)	R 3.2, R 3.3	

Lake Fringe Wetlands

Map of:	To answer questions:	Figure #
Cowardin plant classes	L 1.1, L 4.1, H 1.1, H 1.4	
Plant cover of trees, shrubs, and herbaceous plants	L 1.2	
Boundary of area within 150 ft of the wetland (<i>can be added to another figure</i>)	L 2.2	
1 km Polygon: Area that extends 1 km from entire wetland edge - including polygons for accessible habitat and undisturbed habitat	H 2.1, H 2.2, H 2.3	
Screen capture of map of 303(d) listed waters in basin (from Ecology website)	L 3.1, L 3.2	
Screen capture of list of TMDLs for WRIA in which unit is found (from web)	L 3.3	

Slope Wetlands

Map of:	To answer questions:	Figure #
Cowardin plant classes	H 1.1, H 1.4	
Hydroperiods	H 1.2	
Plant cover of dense trees, shrubs, and herbaceous plants	S 1.3	
Plant cover of dense, rigid trees, shrubs, and herbaceous plants (<i>can be added to figure above</i>)	S 4.1	
Boundary of 150 ft buffer (<i>can be added to another figure</i>)	S 2.1, S 5.1	
1 km Polygon: Area that extends 1 km from entire wetland edge - including polygons for accessible habitat and undisturbed habitat	H 2.1, H 2.2, H 2.3	
Screen capture of map of 303(d) listed waters in basin (from Ecology website)	S 3.1, S 3.2	
Screen capture of list of TMDLs for WRIA in which unit is found (from web)	S 3.3	

Wetland name or number A

NO – go to 6

YES – The wetland class is **Riverine**

NOTE: The Riverine unit can contain depressions that are filled with water when the river is not flooding

6. Is the entire wetland unit in a topographic depression in which water ponds, or is saturated to the surface, at some time during the year? *This means that any outlet, if present, is higher than the interior of the wetland.*

NO – go to 7

YES – The wetland class is **Depressional**

7. Is the entire wetland unit located in a very flat area with no obvious depression and no overbank flooding? The unit does not pond surface water more than a few inches. The unit seems to be maintained by high groundwater in the area. The wetland may be ditched, but has no obvious natural outlet.

NO – go to 8

YES – The wetland class is **Depressional**

8. Your wetland unit seems to be difficult to classify and probably contains several different HGM classes. For example, seeps at the base of a slope may grade into a riverine floodplain, or a small stream within a Depressional wetland has a zone of flooding along its sides. **GO BACK AND IDENTIFY WHICH OF THE HYDROLOGIC REGIMES DESCRIBED IN QUESTIONS 1-7 APPLY TO DIFFERENT AREAS IN THE UNIT** (make a rough sketch to help you decide). Use the following table to identify the appropriate class to use for the rating system if you have several HGM classes present within the wetland unit being scored.

NOTE: Use this table only if the class that is recommended in the second column represents 10% or more of the total area of the wetland unit being rated. If the area of the HGM class listed in column 2 is less than 10% of the unit; classify the wetland using the class that represents more than 90% of the total area.

HGM classes within the wetland unit being rated	HGM class to use in rating
Slope + Riverine	Riverine
Slope + Depressional	Depressional
Slope + Lake Fringe	Lake Fringe
Depressional + Riverine along stream within boundary of depression	Depressional
Depressional + Lake Fringe	Depressional
Riverine + Lake Fringe	Riverine
Salt Water Tidal Fringe and any other class of freshwater wetland	Treat as ESTUARINE

*If you are still unable to determine which of the above criteria apply to your wetland, or if you have **more than 2 HGM classes** within a wetland boundary, classify the wetland as Depressional for the rating.*

Wetland name or number A

DEPRESSIONAL AND FLATS WETLANDS	
Water Quality Functions - Indicators that the site functions to improve water quality	
D 1.0. Does the site have the potential to improve water quality?	
D 1.1. <u>Characteristics of surface water outflows from the wetland:</u> Wetland is a depression or flat depression (QUESTION 7 on key) with no surface water leaving it (no outlet). Wetland has an intermittently flowing stream or ditch, OR highly constricted permanently flowing outlet. Wetland has an unconstricted, or slightly constricted, surface outlet that is permanently flowing Wetland is a flat depression (QUESTION 7 on key), whose outlet is a permanently flowing ditch.	points = 3 points = 2 points = 1 points = 1 2
D 1.2. <u>The soil 2 in below the surface (or duff layer) is true clay or true organic (use NRCS definitions).</u> Yes = 4 No = 0	0
D 1.3. <u>Characteristics and distribution of persistent plants (Emergent, Scrub-shrub, and/or Forested Cowardin classes):</u> Wetland has persistent, ungrazed, plants > 95% of area Wetland has persistent, ungrazed, plants > 1/2 of area Wetland has persistent, ungrazed plants > 1/10 of area Wetland has persistent, ungrazed plants < 1/10 of area	points = 5 points = 3 points = 1 points = 0 0
D 1.4. <u>Characteristics of seasonal ponding or inundation:</u> <i>This is the area that is ponded for at least 2 months. See description in manual.</i> Area seasonally ponded is > 1/2 total area of wetland Area seasonally ponded is > 1/4 total area of wetland Area seasonally ponded is < 1/4 total area of wetland	points = 4 points = 2 points = 0 2
Total for D 1	4 Add the points in the boxes above

Rating of Site Potential If score is: 12-16 = H 6-11 = M X 0-5 = L Record the rating on the first page

D 2.0. Does the landscape have the potential to support the water quality function of the site?	
D 2.1. Does the wetland unit receive stormwater discharges?	Yes = 1 No = 0 0
D 2.2. Is > 10% of the area within 150 ft of the wetland in land uses that generate pollutants?	Yes = 1 No = 0 1
D 2.3. Are there septic systems within 250 ft of the wetland?	Yes = 1 No = 0 0
D 2.4. Are there other sources of pollutants coming into the wetland that are not listed in questions D 2.1-D 2.3? Source _____	Yes = 1 No = 0 0
Total for D 2	1 Add the points in the boxes above

Rating of Landscape Potential If score is: 3 or 4 = H X 1 or 2 = M 0 = L Record the rating on the first page

D 3.0. Is the water quality improvement provided by the site valuable to society?	
D 3.1. Does the wetland discharge directly (i.e., within 1 mi) to a stream, river, lake, or marine water that is on the 303(d) list?	Yes = 1 No = 0 1
D 3.2. Is the wetland in a basin or sub-basin where an aquatic resource is on the 303(d) list?	Yes = 1 No = 0 1
D 3.3. Has the site been identified in a watershed or local plan as important for maintaining water quality (answer YES if there is a TMDL for the basin in which the unit is found)?	Yes = 2 No = 0 0
Total for D 3	2 Add the points in the boxes above

Rating of Value If score is: X 2-4 = H 1 = M 0 = L Record the rating on the first page

NOTES and FIELD OBSERVATIONS:

Septic tank decommissioned, removed, and backfilled in 2018

Wetland name or number A

DEPRESSIONAL AND FLATS WETLANDS

Hydrologic Functions - Indicators that the site functions to reduce flooding and stream degradation

D 4.0. Does the site have the potential to reduce flooding and erosion?		
D 4.1. Characteristics of surface water outflows from the wetland:		
Wetland is a depression or flat depression with no surface water leaving it (no outlet)	points = 4	2
Wetland has an intermittently flowing stream or ditch, OR highly constricted permanently flowing outlet	points = 2	
Wetland is a flat depression (QUESTION 7 on key), whose outlet is a permanently flowing ditch	points = 1	
Wetland has an unconstricted, or slightly constricted, surface outlet that is permanently flowing	points = 0	
D 4.2. Depth of storage during wet periods: Estimate the height of ponding above the bottom of the outlet. For wetlands with no outlet, measure from the surface of permanent water or if dry, the deepest part.		
Marks of ponding are 3 ft or more above the surface or bottom of outlet	points = 7	3
Marks of ponding between 2 ft to < 3 ft from surface or bottom of outlet	points = 5	
Marks are at least 0.5 ft to < 2 ft from surface or bottom of outlet	points = 3	
The wetland is a "headwater" wetland	points = 3	
Wetland is flat but has small depressions on the surface that trap water	points = 1	
Marks of ponding less than 0.5 ft (6 in)	points = 0	
D 4.3. Contribution of the wetland to storage in the watershed: Estimate the ratio of the area of upstream basin contributing surface water to the wetland to the area of the wetland unit itself.		
The area of the basin is less than 10 times the area of the unit	points = 5	0
The area of the basin is 10 to 100 times the area of the unit	points = 3	
The area of the basin is more than 100 times the area of the unit	points = 0	
Entire wetland is in the Flats class	points = 5	
Total for D 4	Add the points in the boxes above	5

Rating of Site Potential If score is: 12-16 = H 6-11 = M X 0-5 = L Record the rating on the first page

D 5.0. Does the landscape have the potential to support hydrologic functions of the site?		
D 5.1. Does the wetland receive stormwater discharges?	Yes = 1 No = 0	0
D 5.2. Is >10% of the area within 150 ft of the wetland in land uses that generate excess runoff?	Yes = 1 No = 0	1
D 5.3. Is more than 25% of the contributing basin of the wetland covered with intensive human land uses (residential at >1 residence/ac, urban, commercial, agriculture, etc.)?	Yes = 1 No = 0	0
Total for D 5	Add the points in the boxes above	1

Rating of Landscape Potential If score is: 3 = H X 1 or 2 = M 0 = L Record the rating on the first page

D 6.0. Are the hydrologic functions provided by the site valuable to society?		
D 6.1. The unit is in a landscape that has flooding problems. Choose the description that best matches conditions around the wetland unit being rated. Do not add points. Choose the highest score if more than one condition is met.		
The wetland captures surface water that would otherwise flow down-gradient into areas where flooding has damaged human or natural resources (e.g., houses or salmon redds):		1
• Flooding occurs in a sub-basin that is immediately down-gradient of unit.	points = 2	
• Surface flooding problems are in a sub-basin farther down-gradient.	points = 1	
Flooding from groundwater is an issue in the sub-basin.	points = 1	
The existing or potential outflow from the wetland is so constrained by human or natural conditions that the water stored by the wetland cannot reach areas that flood. Explain why _____	points = 0	
There are no problems with flooding downstream of the wetland.	points = 0	
D 6.2. Has the site been identified as important for flood storage or flood conveyance in a regional flood control plan?	Yes = 2 No = 0	0
Total for D 6	Add the points in the boxes above	1

Rating of Value If score is: 2-4 = H X 1 = M 0 = L Record the rating on the first page

Wetland name or number A

These questions apply to wetlands of all HGM classes.

HABITAT FUNCTIONS - Indicators that site functions to provide important habitat

H 1.0. Does the site have the potential to provide habitat?

H 1.1. Structure of plant community: *Indicators are Cowardin classes and strata within the Forested class. Check the Cowardin plant classes in the wetland. Up to 10 patches may be combined for each class to meet the threshold of ¼ ac or more than 10% of the unit if it is smaller than 2.5 ac. Add the number of structures checked.*

- Aquatic bed 4 structures or more: points = 4
 - Emergent 3 structures: points = 2
 - Scrub-shrub (areas where shrubs have > 30% cover) 2 structures: points = 1
 - Forested (areas where trees have > 30% cover) 1 structure: points = 0
- If the unit has a Forested class, check if:*
- The Forested class has 3 out of 5 strata (canopy, sub-canopy, shrubs, herbaceous, moss/ground-cover) that each cover 20% within the Forested polygon

0

H 1.2. Hydroperiods

Check the types of water regimes (hydroperiods) present within the wetland. The water regime has to cover more than 10% of the wetland or ¼ ac to count (*see text for descriptions of hydroperiods*).

- Permanently flooded or inundated 4 or more types present: points = 3
- Seasonally flooded or inundated 3 types present: points = 2
- Occasionally flooded or inundated 2 types present: points = 1
- Saturated only 1 type present: points = 0
- Permanently flowing stream or river in, or adjacent to, the wetland
- Seasonally flowing stream in, or adjacent to, the wetland
- Lake Fringe wetland** **2 points**
- Freshwater tidal wetland** **2 points**

1

H 1.3. Richness of plant species

Count the number of plant species in the wetland that cover at least 10 ft².

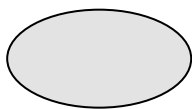
Different patches of the same species can be combined to meet the size threshold and you do not have to name the species. Do not include Eurasian milfoil, reed canarygrass, purple loosestrife, Canadian thistle

- If you counted: > 19 species points = 2
- 5 - 19 species points = 1
- < 5 species points = 0

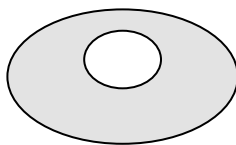
1

H 1.4. Interspersion of habitats

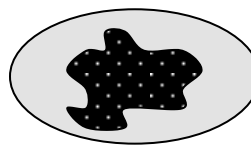
Decide from the diagrams below whether interspersion among Cowardin plants classes (described in H 1.1), or the classes and unvegetated areas (can include open water or mudflats) is high, moderate, low, or none. *If you have four or more plant classes or three classes and open water, the rating is always high.*



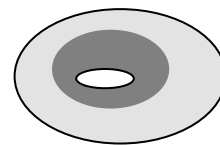
None = 0 points



Low = 1 point

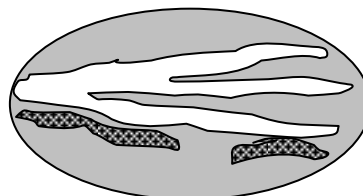
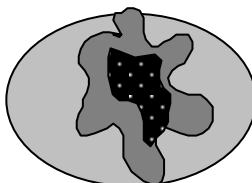
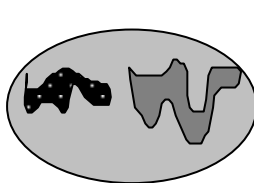


Moderate = 2 points



0

All three diagrams in this row are **HIGH** = 3points



Wetland name or number A

<p>H 1.5. Special habitat features:</p> <p>Check the habitat features that are present in the wetland. <i>The number of checks is the number of points.</i></p> <p><input type="checkbox"/> Large, downed, woody debris within the wetland (> 4 in diameter and 6 ft long).</p> <p><input type="checkbox"/> Standing snags (dbh > 4 in) within the wetland</p> <p><input type="checkbox"/> Undercut banks are present for at least 6.6 ft (2 m) and/or overhanging plants extends at least 3.3 ft (1 m) over a stream (or ditch) in, or contiguous with the wetland, for at least 33 ft (10 m)</p> <p><input type="checkbox"/> Stable steep banks of fine material that might be used by beaver or muskrat for denning (> 30 degree slope) OR signs of recent beaver activity are present (<i>cut shrubs or trees that have not yet weathered where wood is exposed</i>)</p> <p><input type="checkbox"/> At least ¼ ac of thin-stemmed persistent plants or woody branches are present in areas that are permanently or seasonally inundated (<i>structures for egg-laying by amphibians</i>)</p> <p><input checked="" type="checkbox"/> Invasive plants cover less than 25% of the wetland area in every stratum of plants (<i>see H 1.1 for list of strata</i>)</p>	1
<p>Total for H 1</p>	<p>Add the points in the boxes above</p> <p>3</p>

Rating of Site Potential If score is: 15-18 = H 7-14 = M 0-6 = L *Record the rating on the first page*

<p>H 2.0. Does the landscape have the potential to support the habitat functions of the site?</p>	
<p>H 2.1. Accessible habitat (include <i>only habitat that directly abuts wetland unit</i>).</p> <p>Calculate: <input type="text" value="0.00"/> % undisturbed habitat + [(% moderate and low intensity land uses) <input type="text" value="0.83"/> /2] = <u>0.415</u> %</p> <p>If total accessible habitat is:</p> <p>> 1/3 (33.3%) of 1 km Polygon points = 3</p> <p>20-33% of 1 km Polygon points = 2</p> <p>10-19% of 1 km Polygon points = 1</p> <p>< 10% of 1 km Polygon points = 0</p>	0
<p>H 2.2. Undisturbed habitat in 1 km Polygon around the wetland.</p> <p>Calculate: <input type="text" value="3.52"/> % undisturbed habitat + [(% moderate and low intensity land uses) <input type="text" value="26.07"/> /2] = <u>16.555</u> %</p> <p>Undisturbed habitat > 50% of Polygon points = 3</p> <p>Undisturbed habitat 10-50% and in 1-3 patches points = 2</p> <p>Undisturbed habitat 10-50% and > 3 patches points = 1</p> <p>Undisturbed habitat < 10% of 1 km Polygon points = 0</p>	1
<p>H 2.3. Land use intensity in 1 km Polygon: If</p> <p>> 50% of 1 km Polygon is high intensity land use points = (- 2)</p> <p>≤ 50% of 1 km Polygon is high intensity points = 0</p>	-2
<p>Total for H 2</p>	<p>Add the points in the boxes above</p> <p>-1</p>

Rating of Landscape Potential If score is: 4-6 = H 1-3 = M < 1 = L *Record the rating on the first page*

<p>H 3.0. Is the habitat provided by the site valuable to society?</p>	
<p>H 3.1. Does the site provide habitat for species valued in laws, regulations, or policies? <i>Choose only the highest score that applies to the wetland being rated.</i></p> <p>Site meets ANY of the following criteria: points = 2</p> <p>— It has 3 or more priority habitats within 100 m (see next page)</p> <p>— It provides habitat for Threatened or Endangered species (any plant or animal on the state or federal lists)</p> <p>— It is mapped as a location for an individual WDFW priority species</p> <p>— It is a Wetland of High Conservation Value as determined by the Department of Natural Resources</p> <p>— It has been categorized as an important habitat site in a local or regional comprehensive plan, in a Shoreline Master Plan, or in a watershed plan</p> <p>Site has 1 or 2 priority habitats (listed on next page) within 100 m points = 1</p> <p><input checked="" type="checkbox"/> Site does not meet any of the criteria above points = 0</p>	0

Rating of Value If score is: 2 = H 1 = M 0 = L *Record the rating on the first page*

Wetland name or number A

WDFW Priority Habitats

Priority habitats listed by WDFW (see complete descriptions of WDFW priority habitats, and the counties in which they can be found, in: Washington Department of Fish and Wildlife. 2008. Priority Habitat and Species List. Olympia, Washington. 177 pp. <http://wdfw.wa.gov/publications/00165/wdfw00165.pdf> or access the list from here: <http://wdfw.wa.gov/conservation/phs/list/>)

Count how many of the following priority habitats are within 330 ft (100 m) of the wetland unit: **NOTE:** *This question is independent of the land use between the wetland unit and the priority habitat.*

- **Aspen Stands:** Pure or mixed stands of aspen greater than 1 ac (0.4 ha).
- **Biodiversity Areas and Corridors:** Areas of habitat that are relatively important to various species of native fish and wildlife (*full descriptions in WDFW PHS report*).
- **Herbaceous Balds:** Variable size patches of grass and forbs on shallow soils over bedrock.
- **Old-growth/Mature forests:** Old-growth west of Cascade crest – Stands of at least 2 tree species, forming a multi-layered canopy with occasional small openings; with at least 8 trees/ac (20 trees/ha) > 32 in (81 cm) dbh or > 200 years of age. Mature forests – Stands with average diameters exceeding 21 in (53 cm) dbh; crown cover may be less than 100%; decay, decadence, numbers of snags, and quantity of large downed material is generally less than that found in old-growth; 80-200 years old west of the Cascade crest.
- **Oregon White Oak:** Woodland stands of pure oak or oak/conifer associations where canopy coverage of the oak component is important (*full descriptions in WDFW PHS report p. 158 – see web link above*).
- **Riparian:** The area adjacent to aquatic systems with flowing water that contains elements of both aquatic and terrestrial ecosystems which mutually influence each other.
- **Westside Prairies:** Herbaceous, non-forested plant communities that can either take the form of a dry prairie or a wet prairie (*full descriptions in WDFW PHS report p. 161 – see web link above*).
- **Instream:** The combination of physical, biological, and chemical processes and conditions that interact to provide functional life history requirements for instream fish and wildlife resources.
- **Nearshore:** Relatively undisturbed nearshore habitats. These include Coastal Nearshore, Open Coast Nearshore, and Puget Sound Nearshore. (*full descriptions of habitats and the definition of relatively undisturbed are in WDFW report – see web link on previous page*).
- **Caves:** A naturally occurring cavity, recess, void, or system of interconnected passages under the earth in soils, rock, ice, or other geological formations and is large enough to contain a human.
- **Cliffs:** Greater than 25 ft (7.6 m) high and occurring below 5000 ft elevation.
- **Talus:** Homogenous areas of rock rubble ranging in average size 0.5 - 6.5 ft (0.15 - 2.0 m), composed of basalt, andesite, and/or sedimentary rock, including riprap slides and mine tailings. May be associated with cliffs.
- **Snags and Logs:** Trees are considered snags if they are dead or dying and exhibit sufficient decay characteristics to enable cavity excavation/use by wildlife. Priority snags have a diameter at breast height of > 20 in (51 cm) in western Washington and are > 6.5 ft (2 m) in height. Priority logs are > 12 in (30 cm) in diameter at the largest end, and > 20 ft (6 m) long.

Note: All vegetated wetlands are by definition a priority habitat but are not included in this list because they are addressed elsewhere.

Wetland name or number A

CATEGORIZATION BASED ON SPECIAL CHARACTERISTICS

Wetland Type	Category
<i>Check off any criteria that apply to the wetland. Circle the category when the appropriate criteria are met.</i>	
<p>SC 1.0. Estuarine wetlands</p> <p>Does the wetland meet the following criteria for Estuarine wetlands?</p> <p><input type="checkbox"/> The dominant water regime is tidal, <input type="checkbox"/> Vegetated, and <input type="checkbox"/> With a salinity greater than 0.5 ppt <input type="checkbox"/> Yes –Go to SC 1.1 <input checked="" type="checkbox"/> No= Not an estuarine wetland</p>	
<p>SC 1.1. Is the wetland within a National Wildlife Refuge, National Park, National Estuary Reserve, Natural Area Preserve, State Park or Educational, Environmental, or Scientific Reserve designated under WAC 332-30-151? <input type="checkbox"/> Yes = Category I <input type="checkbox"/> No - Go to SC 1.2</p>	
<p>SC 1.2. Is the wetland unit at least 1 ac in size and meets at least two of the following three conditions?</p> <p><input type="checkbox"/> The wetland is relatively undisturbed (has no diking, ditching, filling, cultivation, grazing, and has less than 10% cover of non-native plant species. (If non-native species are <i>Spartina</i>, see page 25) <input type="checkbox"/> At least ¾ of the landward edge of the wetland has a 100 ft buffer of shrub, forest, or un-grazed or unmowed grassland. <input type="checkbox"/> The wetland has at least two of the following features: tidal channels, depressions with open water, or contiguous freshwater wetlands. <input type="checkbox"/> Yes = Category I <input type="checkbox"/> No = Category II</p>	
<p>SC 2.0. Wetlands of High Conservation Value (WHCV)</p> <p>SC 2.1. Has the WA Department of Natural Resources updated their website to include the list of Wetlands of High Conservation Value? <input type="checkbox"/> Yes – Go to SC 2.2 <input checked="" type="checkbox"/> No – Go to SC 2.3</p> <p>SC 2.2. Is the wetland listed on the WDNR database as a Wetland of High Conservation Value? <input type="checkbox"/> Yes = Category I <input checked="" type="checkbox"/> No = Not a WHCV</p> <p>SC 2.3. Is the wetland in a Section/Township/Range that contains a Natural Heritage wetland? http://www1.dnr.wa.gov/nhp/refdesk/datasearch/wnhpwetlands.pdf <input type="checkbox"/> Yes – Contact WNHP/WDNR and go to SC 2.4 <input checked="" type="checkbox"/> No = Not a WHCV</p> <p>SC 2.4. Has WDNR identified the wetland within the S/T/R as a Wetland of High Conservation Value and listed it on their website? <input type="checkbox"/> Yes = Category I <input checked="" type="checkbox"/> No = Not a WHCV</p>	
<p>SC 3.0. Bogs</p> <p>Does the wetland (or any part of the unit) meet both the criteria for soils and vegetation in bogs? <i>Use the key below. If you answer YES you will still need to rate the wetland based on its functions.</i></p> <p>SC 3.1. Does an area within the wetland unit have organic soil horizons, either peats or mucks, that compose 16 in or more of the first 32 in of the soil profile? <input type="checkbox"/> Yes – Go to SC 3.3 <input checked="" type="checkbox"/> No – Go to SC 3.2</p> <p>SC 3.2. Does an area within the wetland unit have organic soils, either peats or mucks, that are less than 16 in deep over bedrock, or an impermeable hardpan such as clay or volcanic ash, or that are floating on top of a lake or pond? <input type="checkbox"/> Yes – Go to SC 3.3 <input checked="" type="checkbox"/> No = Is not a bog</p> <p>SC 3.3. Does an area with peats or mucks have more than 70% cover of mosses at ground level, AND at least a 30% cover of plant species listed in Table 4? <input type="checkbox"/> Yes = Is a Category I bog <input type="checkbox"/> No – Go to SC 3.4 NOTE: If you are uncertain about the extent of mosses in the understory, you may substitute that criterion by measuring the pH of the water that seeps into a hole dug at least 16 in deep. If the pH is less than 5.0 and the plant species in Table 4 are present, the wetland is a bog.</p> <p>SC 3.4. Is an area with peats or mucks forested (> 30% cover) with Sitka spruce, subalpine fir, western red cedar, western hemlock, lodgepole pine, quaking aspen, Engelmann spruce, or western white pine, AND any of the species (or combination of species) listed in Table 4 provide more than 30% of the cover under the canopy? <input type="checkbox"/> Yes = Is a Category I bog <input type="checkbox"/> No = Is not a bog</p>	

Wetland name or number A

<p>SC 4.0. Forested Wetlands</p> <p>Does the wetland have at least <u>1 contiguous acre</u> of forest that meets one of these criteria for the WA Department of Fish and Wildlife's forests as priority habitats? <i>If you answer YES you will still need to rate the wetland based on its functions.</i></p> <ul style="list-style-type: none"> — Old-growth forests (west of Cascade crest): Stands of at least two tree species, forming a multi-layered canopy with occasional small openings; with at least 8 trees/ac (20 trees/ha) that are at least 200 years of age OR have a diameter at breast height (dbh) of 32 in (81 cm) or more. — Mature forests (west of the Cascade Crest): Stands where the largest trees are 80- 200 years old OR the species that make up the canopy have an average diameter (dbh) exceeding 21 in (53 cm). <p style="text-align: right;"><input type="checkbox"/> Yes = Category I <input checked="" type="checkbox"/> No = Not a forested wetland for this section</p>	
<p>SC 5.0. Wetlands in Coastal Lagoons</p> <p>Does the wetland meet all of the following criteria of a wetland in a coastal lagoon?</p> <ul style="list-style-type: none"> — The wetland lies in a depression adjacent to marine waters that is wholly or partially separated from marine waters by sandbanks, gravel banks, shingle, or, less frequently, rocks — The lagoon in which the wetland is located contains ponded water that is saline or brackish (> 0.5 ppt) during most of the year in at least a portion of the lagoon (<i>needs to be measured near the bottom</i>) <p style="text-align: right;"><input type="checkbox"/> Yes – Go to SC 5.1 <input checked="" type="checkbox"/> No = Not a wetland in a coastal lagoon</p> <p>SC 5.1. Does the wetland meet all of the following three conditions?</p> <ul style="list-style-type: none"> — The wetland is relatively undisturbed (has no diking, ditching, filling, cultivation, grazing), and has less than 20% cover of aggressive, opportunistic plant species (see list of species on p. 100). — At least ¾ of the landward edge of the wetland has a 100 ft buffer of shrub, forest, or un-grazed or unmowed grassland. — The wetland is larger than 1/10 ac (4350 ft²) <p style="text-align: right;"><input type="checkbox"/> Yes = Category I <input type="checkbox"/> No = Category II</p>	
<p>SC 6.0. Interdunal Wetlands</p> <p>Is the wetland west of the 1889 line (also called the Western Boundary of Upland Ownership or WBUO)? <i>If you answer yes you will still need to rate the wetland based on its habitat functions.</i></p> <p>In practical terms that means the following geographic areas:</p> <ul style="list-style-type: none"> — Long Beach Peninsula: Lands west of SR 103 — Grayland-Westport: Lands west of SR 105 — Ocean Shores-Copalis: Lands west of SR 115 and SR 109 <p style="text-align: right;"><input type="checkbox"/> Yes – Go to SC 6.1 <input checked="" type="checkbox"/> No = not an interdunal wetland for rating</p> <p>SC 6.1. Is the wetland 1 ac or larger and scores an 8 or 9 for the habitat functions on the form (rates H,H,H or H,H,M for the three aspects of function)? <input type="checkbox"/> Yes = Category I <input type="checkbox"/> No – Go to SC 6.2</p> <p>SC 6.2. Is the wetland 1 ac or larger, or is it in a mosaic of wetlands that is 1 ac or larger? <input type="checkbox"/> Yes = Category II <input type="checkbox"/> No – Go to SC 6.3</p> <p>SC 6.3. Is the unit between 0.1 and 1 ac, or is it in a mosaic of wetlands that is between 0.1 and 1 ac? <input type="checkbox"/> Yes = Category III <input type="checkbox"/> No = Category IV</p>	
<p>Category of wetland based on Special Characteristics</p> <p>If you answered No for all types, enter "Not Applicable" on Summary Form</p>	

Wetland name or number A

This page left blank intentionally

Appendix F – Wetland Rating Maps

COWARDIN MAP



H.1.1 Presence Cowardin Classes	
Wetland A	
Aquatic Bed	0.0%
Emergent	100.0%
Scrub-Shrub	0.0%
Forested	0.0%



Soundview Consultants LLC
 Environmental Assessment • Planning • Land Use Solutions
 2907 Harborview Dr., Suite D, Gig Harbor, WA 98335
 Phone: (253) 514-8952 Fax: (253) 514-8954
www.soundviewconsultants.com

TODD ROAD
 221 TODD RD NW
 PUYALLUP, WA
 98371

PIERCE COUNTY PARCEL NUMBERS:
 0420211002 & 0420211012

DATE: 1/20/2023
 JOB: 1520.0006
 BY: DLS/JML
 SCALE: 1" = 150'
 FIGURE NO. 1 of 5

HYDROPERIOD MAP



H.1.1 Presence Hydroperiod Classes	
Wetland A	
Seasonally Flooded or Inundated	11.8%
Saturated Only	88.2%



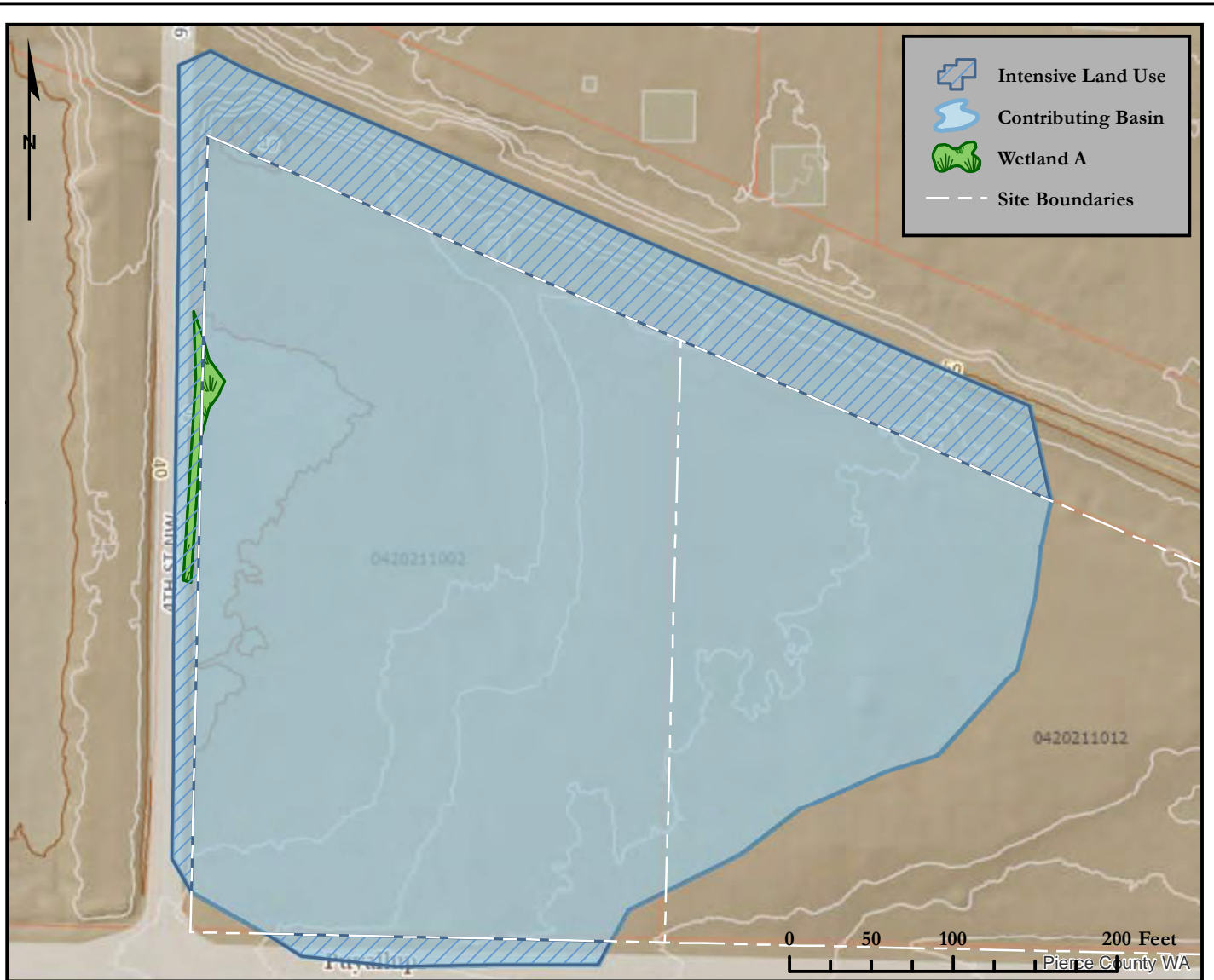
Soundview Consultants LLC
 Environmental Assessment • Planning • Land Use Solutions
 2907 Harborview Dr., Suite D, Gig Harbor, WA 98335
 Phone: (253) 514-8952 Fax: (253) 514-8954
www.soundviewconsultants.com

TODD ROAD
 221 TODD RD NW
 PUYALLUP, WA
 98371

PIERCE COUNTY PARCEL NUMBERS:
 0420211002 & 0420211012

DATE: 1/20/2023
 JOB: 1520.0006
 BY: DLS/DS
 SCALE: 1" = 80'
 FIGURE NO. 2 of 5

CONTRIBUTING BASIN MAP



D.4.0		
D.4.3		
	Area of Contributing Basin (SF)	209,950
	Area of Wetland A (SF)	1,409
	Percent of Wetland A within Contributing Basin	0.671%
D.5.0		
D.5.3		
	Area of Contributing Basin	209,950
	Area of Intensive Human Land Uses	36,872
	Percent of Intensive Human Land Use within Contributing Basin	18%



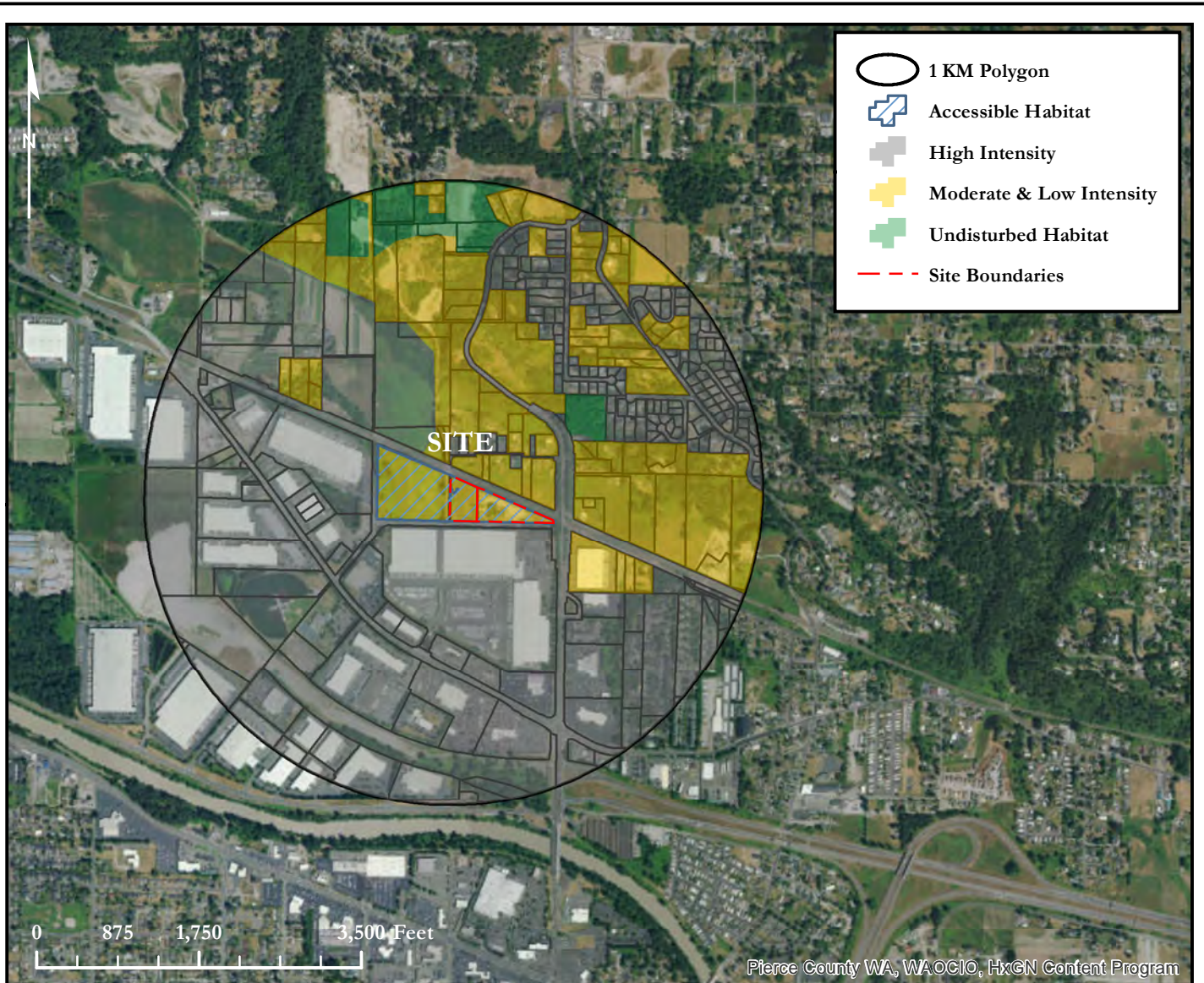
Soundview Consultants LLC
 Environmental Assessment • Planning • Land Use Solutions
 2907 Harborview Dr., Suite D, Gig Harbor, WA 98335
 Phone: (253) 514-8952 Fax: (253) 514-8954
www.soundviewconsultants.com

TODD ROAD
 221 TODD RD NW
 PUYALLUP, WA
 98371

PIERCE COUNTY PARCEL NUMBERS:
 0420211002 & 0420211012

DATE: 1/20/2023
JOB: 1520.0006
BY: DLS/JML
SCALE: 1" = 100'
FIGURE NO. 3 of 5

HABITAT MAP



H.2.0 Wetland A		
H.2.1		
	Abutting Undisturbed Habitat	0.00%
	Abutting Moderate & Low Intensity Land Uses	0.83%
	Accessible Habitat	0.41%
H.2.2		
	Undisturbed Habitat	3.52%
	Moderate & Low Intensity Land Uses	26.07%
	Undisturbed Habitat in 1 KM Polygon	16.55%
H.2.3		
	High Intensity Land Use in 1 KM Polygon	70.41%



Soundview Consultants LLC
 Environmental Assessment • Planning • Land Use Solutions
 2907 Harborview Dr., Suite D, Gig Harbor, WA 98335
 Phone: (253) 514-8952 Fax: (253) 514-8954
www.soundviewconsultants.com




TODD ROAD
 221 TODD RD NW
 PUYALLUP, WA
 98371

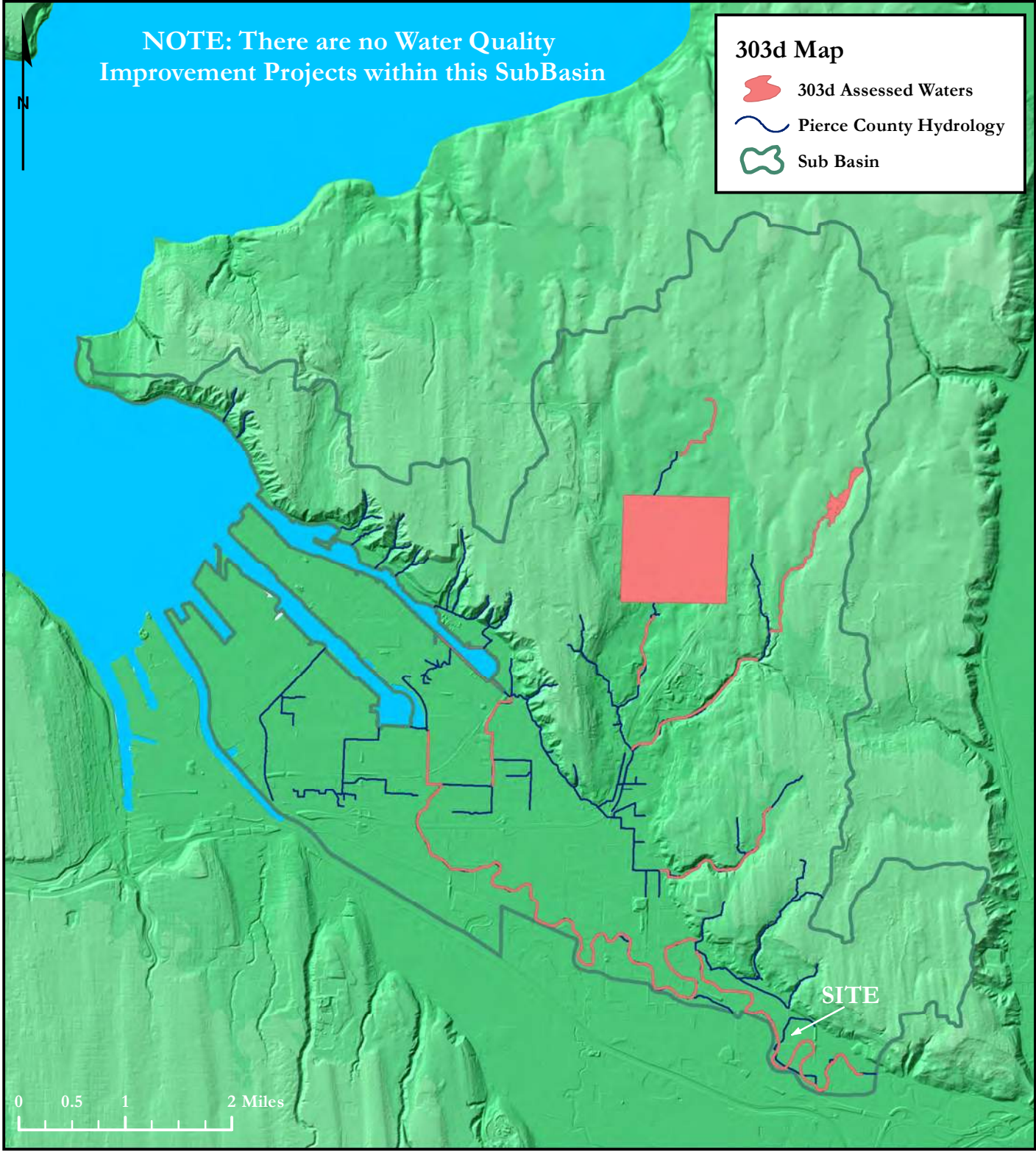
PIERCE COUNTY PARCEL NUMBERS:
 0420211002 & 0420211012

DATE: 1/20/2023
 JOB: 1520.0006
 BY: DLS
 SCALE: 1" = 1,750'
 FIGURE NO. 4 of 5

NOTE: There are no Water Quality Improvement Projects within this SubBasin

303d Map

-  303d Assessed Waters
-  Pierce County Hydrology
-  Sub Basin



0 0.5 1 2 Miles



Soundview Consultants LLC
Environmental Assessment • Planning • Land Use Solutions
2907 Harborview Dr., Suite D, Gig Harbor, WA 98335
Phone: (253) 514-8952 Fax: (253) 514-8954
www.soundviewconsultants.com

TODD ROAD
221 TODD RD NW
PUYALLUP, WA
98371

PIERCE COUNTY PARCEL NUMBERS:
0420211002 & 0420211012

DATE: 1/20/2023
JOB: 1520.0006
BY: DLS/JML
SCALE: 1" = 1 mi
FIGURE NO. 5 of 5

Appendix G – Qualifications

All field inspections, habitat assessments, wetland delineations, and supporting documentation, including this *Wetland, Stream, and Fish and Wildlife Habitat Assessment* prepared for the *PSE Todd Road* project were prepared by, or under the direction of Jon Pickett of SVC. In addition, the field investigations were performed by Kyla Caddey, report preparation was completed by Emma Santana, and additional project oversight and quality assurance / quality control was completed by Rachael Hyland.

Jon Pickett

Associate Principal

Professional Experience: 10+ years

Jon Pickett is an Associate Principal and Senior Scientist with a diverse background in environmental and shoreline compliance and permitting, wetland and stream ecology, fish and wildlife biology, mitigation compliance and design, and environmental planning and land use due diligence. Jon oversees a wide range of large-scale industrial, commercial, and multi-family residential projects throughout Western Washington, providing environmental permitting and regulatory compliance assistance for land use entitlement projects from feasibility through mitigation compliance. Jon performs wetland, stream, and shoreline delineations and fish & wildlife habitat assessments; conducts code and regulation analysis and review; prepares reports and permit applications and documents; provides environmental compliance recommendation; and provides restoration and mitigation design.

Jon earned a Bachelor of Science degree in Natural Resource Sciences from Washington State University and Bachelor of Science and Minor in Forestry from Washington State University. Jon has received 40-hour wetland delineation training (Western Mountains, Valleys, & Coast and Arid West Regional Supplements) and regularly performs wetland, stream, and shoreline delineations. Jon is a Whatcom County Qualified Wetland Specialist and Wildlife Biologist and is a Pierce County Qualified Wetland Specialist. He has been formally trained by WSDOE in the use of the Washington State Wetland Rating System 2014, How to Determine the Ordinary High-Water Mark (Freshwater and Marine), Using Field Indicators for Hydric Soils, and the Using the Credit-Debit Method for Estimating Mitigation Needs.

Kyla Caddey, PWS, Certified Ecologist

Senior Environmental Scientist

Professional Experience: 8 years

Kyla Caddey is a Senior Environmental Scientist with a diverse background in stream and wetland ecology, wildlife ecology and conservation, wildlife and natural resource assessments and monitoring, and riparian habitat restoration at various public and private entities. Kyla has field experience performing in-depth studies in both the Pacific Northwest and Central American ecosystems which included various environmental science research and statistical analysis. Kyla has advanced expertise in federal- and state-listed endangered, threatened, and sensitive species surveys and assessment of aquatic and terrestrial systems throughout the Puget Sound region. She has completed hundreds of wetland delineations and has extensive knowledge and interest in hydric soil identification. As the senior writer, she provides informed project oversight and performs final quality assurance / quality

control on various types of scientific reports for agency submittal, including: Biological Assessments/Evaluations; Wetland, Shoreline, and Fish and Wildlife Habitat Assessments; Mitigation Plans, and Mitigation Monitoring Reports. She currently performs wetland, stream, and shoreline delineations and fish and wildlife habitat assessments; prepares scientific reports; and provides environmental permitting and regulatory compliance assistance to support a wide range of commercial, industrial, and multi-family residential land use projects.

Kyla earned a Bachelor of Science degree in Environmental Science and Resource Management from the University of Washington, Seattle with a focus in Wildlife Conservation and a minor in Quantitative Science. She has also completed additional coursework in Comprehensive Bird Biology from Cornell University. Ms. Caddey is a Certified Professional Wetland Scientist (PWS #3479) through the Society of Wetland Scientists and Certified Ecologist through the Ecological Society of America. She has received 40-hour wetland delineation training (Western Mtns, Valleys, & Coast and Arid West Regional Supplement), is a Pierce County Qualified Wetland Specialist and Wildlife Biologist, and is a USFWS-approved Mazama pocket gopher survey biologist. Kyla has been formally trained through the Washington State Department of Ecology, Coastal Training Program, and the Washington Native Plant Society in winter twig and grass, sedge, and rush identification for Western WA; Using the Credit-Debit Method in Estimating Wetland Mitigation Needs; How to Determine the Ordinary High Water Mark; Using Field Indicators for Hydric Soils; How to Administer Development Permits in Washington Shorelines; Puget Sound Coastal Processes; and Forage Fish Survey Techniques. Additionally, she has received formal training in preparing WSDOT Biological Assessments.

Rachael Hyland, PWS, Certified Ecologist

Senior Environmental Scientist

Professional Experience: 9 years

Rachael Hyland is a Senior Environmental Scientist with extensive wetland and stream delineation and regulatory coordination experience. Rachael has a background in wetland and ecological habitat assessments in various states, most notably Washington, Connecticut, Massachusetts, Rhode Island, and Ohio. She has experience in assessing wetland, stream, riparian, and tidal systems, as well as complicated agricultural and disturbed sites. She currently performs wetland, stream, and shoreline delineations and fish and wildlife habitat assessments; conducts environmental code analysis; and prepares environmental assessment and mitigation reports, biological evaluations, and permit applications to support clients through the regulatory and planning process for various land use projects. She also has extensive knowledge of bats and their associated habitats and white nose syndrome (*Pseudogymnoascus destructans*), a fungal disease affecting bats which was recently documented in Washington.

Rachael earned a Bachelor of Science degree in Ecology and Evolutionary Biology from the University of Connecticut, with additional ecology studies at the graduate level. Rachael is a Professional Wetland Scientist (PWS #3480) through the Society of Wetland Scientists as well as a Certified Ecologist through the Ecological Society of America. She has completed 40-hour wetland delineation training for Western Mountains, Valleys, & Coast and Arid West Regional Supplement, in addition to formal training for the Northcentral and Northeast supplement, and experience with the Midwest, Eastern Mountains and Piedmont, and Atlantic and Gulf Coast supplements. She has also received formal training from the Washington State Department of Ecology in the Using the Revised 2014 Wetland Rating System for Western Washington, How to Determine the Ordinary High Water Mark,

Navigating SEPA, Selecting Wetland Mitigation Sites Using a Watershed Approach, and Wetland Classification. Rachael has also received training from the Washington State Department of Transportation in Biological Assessment Preparation for Transportation Projects and is listed by WSDOT as a junior author for preparing Biological Assessments.

Emma Santana

Staff Scientist

Professional Experience: 2 years

Emma Santana is a Staff Scientist with a diverse background in technical writing, permitting, and marine field work in the Pacific Northwest. Emma earned a Bachelor of Science degree in Environmental Science from Mills College (Oakland, California) and a Master of Science degree in Environmental Science from Western Washington University (Bellingham, Washington). During her studies she received extensive, hands-on experience working in lab and field settings, with a focus on marine and estuarine environments. In her thesis work, she quantified the springtime sedimentary exchange of nutrients and dissolved oxygen with the overlying water across the Salish Sea and worked jointly across with various government agencies. Emma has vast experience completing technical field reports and result assessments and has helped prepare various permits in Washington State.

Emma currently assists in wetland, stream, and shoreline delineations and fish and wildlife habitat assessments; conducts environmental code analysis; and prepares environmental assessment and mitigation reports, biological evaluations, and permit applications to support clients through the regulatory and planning process for various land use projects.

WWHM2012 Project Reports

WWHM2012
PROJECT REPORT

Project Name: 2023-12-01 Pond Design

Site Name: PSE OTC

Site Address: Todd Road

City : Puyallup

Report Date: 12/5/2023

Gage : 38 IN CENTRAL

Data Start : 10/01/1901

Data End : 09/30/2059

Precip Scale: 1.00

Version Date: 2023/03/31

Version : 4.2.19

Low Flow Threshold for POC 1 : 50 Percent of the 2 Year

High Flow Threshold for POC 1: 50 year

PREDEVELOPED LAND USE

Name : On-site Pre

Bypass: No

GroundWater: No

<u>Pervious Land Use</u>	<u>acre</u>
C, Forest, Flat	5.79
Pervious Total	5.79
<u>Impervious Land Use</u>	<u>acre</u>
PARKING FLAT	0.306
Impervious Total	0.306
Basin Total	6.096

Element Flows To:

Surface	Interflow	Groundwater
---------	-----------	-------------

Name : Off-Site Pre

Bypass: No

GroundWater: No

<u>Pervious Land Use</u>	<u>acre</u>
C, Forest, Flat	.249
Pervious Total	0.249



<u>Impervious Land Use</u>	<u>acre</u>
PARKING FLAT	0.162
Impervious Total	0.162
Basin Total	0.411

Element Flows To:		
Surface	Interflow	Groundwater

MITIGATED LAND USE

Name : On-site Post
 Bypass: No

GroundWater: No

<u>Pervious Land Use</u>	<u>acre</u>
C, Pasture, Flat	1.022
Pervious Total	1.022

<u>Impervious Land Use</u>	<u>acre</u>
ROADS FLAT	2.506
ROOF TOPS FLAT	0.987
POND	0.574
Impervious Total	4.067
Basin Total	5.089

Element Flows To:		
Surface	Interflow	Groundwater
Vault 1	Vault 1	

Name : Vault 1
 Width : 147 ft.
 Length : 147 ft.
 Depth: 4.3 ft.
Discharge Structure
 Riser Height: 3.3 ft.
 Riser Diameter: 18 in.
 Notch Type: Rectangular
 Notch Width: 0.042 ft.
 Notch Height: 1.500 ft.
 Orifice 1 Diameter: 1.52 in. Elevation: 0 ft.

Element Flows To:	
Outlet 1	Outlet 2



Vault Hydraulic Table

Stage (feet)	Area (ac.)	Volume (ac-ft.)	Discharge (cfs)	Infilt (cfs)
0.0000	0.496	0.000	0.000	0.000
0.0478	0.496	0.023	0.013	0.000
0.0956	0.496	0.047	0.019	0.000
0.1433	0.496	0.071	0.023	0.000
0.1911	0.496	0.094	0.027	0.000
0.2389	0.496	0.118	0.030	0.000
0.2867	0.496	0.142	0.033	0.000
0.3344	0.496	0.165	0.036	0.000
0.3822	0.496	0.189	0.038	0.000
0.4300	0.496	0.213	0.041	0.000
0.4778	0.496	0.237	0.043	0.000
0.5256	0.496	0.260	0.045	0.000
0.5733	0.496	0.284	0.047	0.000
0.6211	0.496	0.308	0.049	0.000
0.6689	0.496	0.331	0.051	0.000
0.7167	0.496	0.355	0.053	0.000
0.7644	0.496	0.379	0.054	0.000
0.8122	0.496	0.402	0.056	0.000
0.8600	0.496	0.426	0.058	0.000
0.9078	0.496	0.450	0.059	0.000
0.9556	0.496	0.474	0.061	0.000
1.0033	0.496	0.497	0.062	0.000
1.0511	0.496	0.521	0.064	0.000
1.0989	0.496	0.545	0.065	0.000
1.1467	0.496	0.568	0.067	0.000
1.1944	0.496	0.592	0.068	0.000
1.2422	0.496	0.616	0.069	0.000
1.2900	0.496	0.639	0.071	0.000
1.3378	0.496	0.663	0.072	0.000
1.3856	0.496	0.687	0.073	0.000
1.4333	0.496	0.711	0.075	0.000
1.4811	0.496	0.734	0.076	0.000
1.5289	0.496	0.758	0.077	0.000
1.5767	0.496	0.782	0.078	0.000
1.6244	0.496	0.805	0.079	0.000
1.6722	0.496	0.829	0.081	0.000
1.7200	0.496	0.853	0.082	0.000
1.7678	0.496	0.876	0.083	0.000
1.8156	0.496	0.900	0.084	0.000
1.8633	0.496	0.924	0.087	0.000
1.9111	0.496	0.948	0.091	0.000
1.9589	0.496	0.971	0.096	0.000
2.0067	0.496	0.995	0.101	0.000
2.0544	0.496	1.019	0.106	0.000
2.1022	0.496	1.042	0.112	0.000
2.1500	0.496	1.066	0.118	0.000
2.1978	0.496	1.090	0.125	0.000
2.2456	0.496	1.114	0.131	0.000
2.2933	0.496	1.137	0.138	0.000
2.3411	0.496	1.161	0.145	0.000
2.3889	0.496	1.185	0.152	0.000
2.4367	0.496	1.208	0.159	0.000
2.4844	0.496	1.232	0.166	0.000
2.5322	0.496	1.256	0.174	0.000
2.5800	0.496	1.279	0.181	0.000



2.6278	0.496	1.303	0.188	0.000
2.6756	0.496	1.327	0.196	0.000
2.7233	0.496	1.351	0.203	0.000
2.7711	0.496	1.374	0.211	0.000
2.8189	0.496	1.398	0.219	0.000
2.8667	0.496	1.422	0.228	0.000
2.9144	0.496	1.445	0.237	0.000
2.9622	0.496	1.469	0.247	0.000
3.0100	0.496	1.493	0.256	0.000
3.0578	0.496	1.516	0.266	0.000
3.1056	0.496	1.540	0.276	0.000
3.1533	0.496	1.564	0.286	0.000
3.2011	0.496	1.588	0.355	0.000
3.2489	0.496	1.611	0.368	0.000
3.2967	0.496	1.635	0.382	0.000
3.3444	0.496	1.659	0.533	0.000
3.3922	0.496	1.682	0.829	0.000
3.4400	0.496	1.706	1.215	0.000
3.4878	0.496	1.730	1.666	0.000
3.5356	0.496	1.753	2.167	0.000
3.5833	0.496	1.777	2.699	0.000
3.6311	0.496	1.801	3.245	0.000
3.6789	0.496	1.825	3.788	0.000
3.7267	0.496	1.848	4.309	0.000
3.7744	0.496	1.872	4.792	0.000
3.8222	0.496	1.896	5.224	0.000
3.8700	0.496	1.919	5.594	0.000
3.9178	0.496	1.943	5.900	0.000
3.9656	0.496	1.967	6.143	0.000
4.0133	0.496	1.990	6.337	0.000
4.0611	0.496	2.014	6.578	0.000
4.1089	0.496	2.038	6.770	0.000
4.1567	0.496	2.062	6.956	0.000
4.2044	0.496	2.085	7.137	0.000
4.2522	0.496	2.109	7.313	0.000
4.3000	0.496	2.133	7.485	0.000
4.3478	0.496	2.156	7.654	0.000
4.3956	0.000	0.000	7.818	0.000

Name : Off-site Bypass

Bypass: Yes

GroundWater: No

<u>Pervious Land Use</u>	<u>acre</u>
C, Pasture, Flat	.172
Pervious Total	0.172
<u>Impervious Land Use</u>	<u>acre</u>
SIDEWALKS FLAT	0.239
Impervious Total	0.239
Basin Total	0.411



Element Flows To:
 Surface Interflow Groundwater

Name : On-site Bypass
 Bypass: Yes

GroundWater: No

<u>Pervious Land Use</u>	<u>acre</u>
C, Pasture, Flat	.972
Pervious Total	0.972
<u>Impervious Land Use</u>	<u>acre</u>
DRIVEWAYS FLAT	0.035
Impervious Total	0.035
Basin Total	1.007

Element Flows To:
 Surface Interflow Groundwater

ANALYSIS RESULTS

Stream Protection Duration

Predeveloped Landuse Totals for POC #1
 Total Pervious Area:6.039
 Total Impervious Area:0.468

Mitigated Landuse Totals for POC #1
 Total Pervious Area:2.166
 Total Impervious Area:4.341

Flow Frequency Return Periods for Predeveloped. POC #1

<u>Return Period</u>	<u>Flow(cfs)</u>
2 year	0.230311
5 year	0.323076
10 year	0.389942
25 year	0.480697
50 year	0.552917
100 year	0.629145

Flow Frequency Return Periods for Mitigated. POC #1

<u>Return Period</u>	<u>Flow(cfs)</u>
2 year	0.172184
5 year	0.233314
10 year	0.279916
25 year	0.346204



0.2655	1365	1058	77	Pass
0.2699	1283	986	76	Pass
0.2743	1174	905	77	Pass
0.2788	1097	844	76	Pass
0.2832	997	739	74	Pass
0.2876	917	663	72	Pass
0.2920	825	577	69	Pass
0.2965	758	513	67	Pass
0.3009	706	457	64	Pass
0.3053	649	401	61	Pass
0.3097	591	356	60	Pass
0.3141	545	313	57	Pass
0.3186	502	285	56	Pass
0.3230	468	258	55	Pass
0.3274	426	225	52	Pass
0.3318	389	204	52	Pass
0.3362	341	182	53	Pass
0.3407	303	161	53	Pass
0.3451	268	147	54	Pass
0.3495	252	136	53	Pass
0.3539	233	114	48	Pass
0.3584	211	99	46	Pass
0.3628	196	90	45	Pass
0.3672	181	83	45	Pass
0.3716	163	78	47	Pass
0.3760	147	65	44	Pass
0.3805	140	60	42	Pass
0.3849	127	56	44	Pass
0.3893	118	53	44	Pass
0.3937	111	51	45	Pass
0.3982	94	47	50	Pass
0.4026	90	47	52	Pass
0.4070	84	43	51	Pass
0.4114	80	38	47	Pass
0.4158	74	37	50	Pass
0.4203	70	35	50	Pass
0.4247	64	33	51	Pass
0.4291	56	29	51	Pass
0.4335	51	25	49	Pass
0.4379	50	22	44	Pass
0.4424	48	20	41	Pass
0.4468	47	19	40	Pass
0.4512	38	17	44	Pass
0.4556	34	16	47	Pass
0.4601	33	16	48	Pass
0.4645	31	15	48	Pass
0.4689	31	14	45	Pass
0.4733	27	12	44	Pass
0.4777	25	10	40	Pass
0.4822	22	9	40	Pass
0.4866	21	6	28	Pass
0.4910	19	5	26	Pass
0.4954	17	4	23	Pass
0.4999	16	3	18	Pass
0.5043	14	2	14	Pass
0.5087	14	0	0	Pass
0.5131	12	0	0	Pass



0.5175	10	0	0	Pass
0.5220	9	0	0	Pass
0.5264	9	0	0	Pass
0.5308	9	0	0	Pass
0.5352	9	0	0	Pass
0.5397	9	0	0	Pass
0.5441	8	0	0	Pass
0.5485	6	0	0	Pass
0.5529	6	0	0	Pass

Water Quality BMP Flow and Volume for POC #1

On-line facility volume: 0.4612 acre-feet
On-line facility target flow: 0.5984 cfs.
Adjusted for 15 min: 0.5984 cfs.
Off-line facility target flow: 0.3442 cfs.
Adjusted for 15 min: 0.3442 cfs.

LID Report

LID Technique	Used for	Total Volume	Volume	Infiltration	Cumulative
Percent	Water Quality	Percent	Through	Volume	Volume
Volume	Water Quality	Treatment?	Facility	(ac-ft.)	Infiltration
Infiltrated	Treated	Needs	(ac-ft)	(ac-ft)	Credit
Vault 1 POC	N		1584.19		N
0.00					
Total Volume Infiltrated			1584.19	0.00	0.00
0.00	0.00	0%	No Treat.	Credit	
Compliance with LID Standard 8					
Duration Analysis Result = Failed					

PerlnD and ImplnD Changes

No changes have been made.

This program and accompanying documentation are provided 'as-is' without warranty of any kind. The entire risk regarding the performance and results of this program is assumed by End User. Clear Creek Solutions Inc. and the governmental licensee or sublicensees disclaim all warranties, either expressed or implied, including but not limited to implied warranties of program and accompanying documentation. In no event shall Clear Creek Solutions Inc. be liable for any damages whatsoever (including without limitation to damages for loss of business profits, loss of business information, business interruption, and the like) arising out of the use of, or inability to use this program even if Clear Creek Solutions Inc. or their authorized representatives have been advised of the possibility of such damages. Software Copyright © by : Clear Creek Solutions, Inc. 2005-2023; All Rights Reserved.



WWHM2012
PROJECT REPORT

Project Name: 2023-12-01 Additional Area

Site Name: PSE OTC
Site Address: Todd Road
City : Puyallup
Report Date: 12/5/2023
Gage : 38 IN CENTRAL
Data Start : 10/01/1901
Data End : 09/30/2059
Precip Scale: 1.00
Version Date: 2023/03/31
Version : 4.2.19

Low Flow Threshold for POC 1 : 50 Percent of the 2 Year

High Flow Threshold for POC 1: 50 year

PREDEVELOPED LAND USE

Name : On-site Pre **These are additional area inflows**
Bypass: No

GroundWater: No

<u>Pervious Land Use</u>	<u>acre</u>
Pervious Total	0
<u>Impervious Land Use</u>	<u>acre</u>
PARKING FLAT	0.306
Impervious Total	0.306
Basin Total	0.306

Element Flows To:
Surface **Interflow** **Groundwater**

Name : Off-Site Pre **These are additional area inflows**

Bypass: No

GroundWater: No

<u>Pervious Land Use</u>	<u>acre</u>
Pervious Total	0
<u>Impervious Land Use</u>	<u>acre</u>



PARKING FLAT	0.162
Impervious Total	0.162
Basin Total	0.162

Element Flows To:		
Surface	Interflow	Groundwater

MITIGATED LAND USE

Name : On-site Post **These are flows to be mitigated**

Bypass: No

GroundWater: No

<u>Pervious Land Use</u>	<u>acre</u>
C, Pasture, Flat	1.688

Pervious Total	1.688
----------------	-------

<u>Impervious Land Use</u>	<u>acre</u>
ROADS FLAT	2.506
ROOF TOPS FLAT	0.987
DRIVEWAYS FLAT	0.035
POND	0.574

Impervious Total	4.102
------------------	-------

Basin Total	5.79
-------------	------

Element Flows To:		
Surface	Interflow	Groundwater

Name : Off-site Bypass **These are flows to be mitigated**

Bypass: No

GroundWater: No

<u>Pervious Land Use</u>	<u>acre</u>
C, Pasture, Flat	.01

Pervious Total	0.01
----------------	------

<u>Impervious Land Use</u>	<u>acre</u>
SIDEWALKS FLAT	0.239

Impervious Total	0.239
------------------	-------

Basin Total	0.249
-------------	-------



Element Flows To:
 Surface Interflow Groundwater

ANALYSIS RESULTS

Stream Protection Duration

Predeveloped Landuse Totals for POC #1
 Total Pervious Area:0
 Total Impervious Area:0.468

Mitigated Landuse Totals for POC #1
 Total Pervious Area:1.698
 Total Impervious Area:4.341

Flow Frequency Return Periods for
 Predeveloped. POC #1

These are additional area inflows

<u>Return Period</u>	<u>Flow(cfs)</u>
2 year	0.164011
5 year	0.220156
10 year	0.260963
25 year	0.316812
50 year	0.361635
100 year	0.409305

Flow Frequency Return Periods for
 Mitigated. POC #1

These are flows to be mitigated

<u>Return Period</u>	<u>Flow(cfs)</u>
2 year	1.540333
5 year	2.06763
10 year	2.450872
25 year	2.975392
50 year	3.396354
100 year	3.844052

Additional Area Inflow Check:
 Existing 100-year peak flow rate from the additional area cannot exceed 50% of the 100-year developed peak flow rate from the area requiring mitigation.
 Existing 100-year peak flow rate from additional area = 0.41 cfs
 Developed 100-year peak flow rate from area requiring mitigation = 3.84 cfs
 $0.41 / 3.84 = 10.7\%$ (less than 50%)

Stream Protection Duration

Annual Peaks for Predeveloped and Mitigated. POC #1

<u>Year</u>	<u>Predeveloped</u>	<u>Mitigated</u>
-------------	---------------------	------------------

<Omitted to conserve paper>

Stream Protection Duration

Ranked Annual Peaks for Predeveloped and Mitigated. POC #1

<u>Rank</u>	<u>Predeveloped</u>	<u>Mitigated</u>
-------------	---------------------	------------------

<Omitted to conserve paper>

Stream Protection Duration

POC #1

The Facility **FAILED**



Facility **FAILED** duration standard for 1+ flows.

Flow(cfs) Predev Mit Percentage Pass/Fail

<Omitted to conserve paper>

The development has an increase in flow durations from 1/2 Predeveloped 2 year flow to the 2 year flow or more than a 10% increase from the 2 year to the 50 year flow. The development has an increase in flow durations for more than 50% of the flows for the range of the duration analysis.

Water Quality BMP Flow and Volume for POC #1

<Omitted to conserve paper>

LID Report

<Omitted to conserve paper>

Perlnd and Implnd Changes

No changes have been made.

This program and accompanying documentation are provided 'as-is' without warranty of any kind. The entire risk regarding the performance and results of this program is assumed by End User. Clear Creek Solutions Inc. and the governmental licensee or sublicensees disclaim all warranties, either expressed or implied, including but not limited to implied warranties of program and accompanying documentation. In no event shall Clear Creek Solutions Inc. be liable for any damages whatsoever (including without limitation to damages for loss of business profits, loss of business information, business interruption, and the like) arising out of the use of, or inability to use this program even if Clear Creek Solutions Inc. or their authorized representatives have been advised of the possibility of such damages. Software Copyright © by : Clear Creek Solutions, Inc. 2005-2023; All Rights Reserved.



WWHM2012
PROJECT REPORT

Project Name: Bioretention-1

Site Name:

Site Address:

City :

Report Date: 12/5/2023

Gage : 38 IN CENTRAL

Data Start : 10/01/1901

Data End : 09/30/2059

Precip Scale: 1.00

Version Date: 2023/03/31

Version : 4.2.19

Low Flow Threshold for POC 1 : 50 Percent of the 2 Year

High Flow Threshold for POC 1: 50 year

PREDEVELOPED LAND USE

Name : Basin 1

Bypass: No

GroundWater: No

<u>Pervious Land Use</u>	<u>acre</u>
C, Forest, Flat	.714
Pervious Total	0.714
<u>Impervious Land Use</u>	<u>acre</u>
Impervious Total	0
Basin Total	0.714

Element Flows To:		
Surface	Interflow	Groundwater

MITIGATED LAND USE

Name : Basin 1

Bypass: No

GroundWater: No

<u>Pervious Land Use</u>	<u>acre</u>
C, Pasture, Flat	.174
Pervious Total	0.174



<u>Impervious Land Use</u>	<u>acre</u>
ROADS FLAT	0.54
Impervious Total	0.54
Basin Total	0.714

Element Flows To:

Surface	Interflow	Groundwater
Surface retention 1	Surface retention 1	

Name : Bioretention 1
 Bottom Length: 160.00 ft.
 Bottom Width: 2.00 ft.
 Material thickness of first layer: 1.5
 Material type for first layer: SMMWW 12 in/hr
 Material thickness of second layer: 1.5
 Material type for second layer: GRAVEL
 Material thickness of third layer: 0
 Material type for third layer: GRAVEL
Underdrain used
 Underdrain Diameter (feet): 0.5
 Orifice Diameter (in.): 5.9
 Offset (in.): 6
 Flow Through Underdrain (ac-ft.): 224.687
 Total Outflow (ac-ft.): 245.584
 Percent Through Underdrain: 91.49
Discharge Structure
 Riser Height: 0.2 ft.
 Riser Diameter: 10 in.

Element Flows To:

Outlet 1	Outlet 2
----------	----------

Bioretention 1 Hydraulic Table

Stage(feet)	Area(ac.)	Volume(ac-ft.)	Discharge(cfs)	Infilt(cfs)
0.0000	0.0817	0.0000	0.0000	0.0000
0.0407	0.0809	0.0001	0.0000	0.0000
0.0813	0.0798	0.0003	0.0000	0.0000
0.1220	0.0787	0.0005	0.0000	0.0000
0.1626	0.0776	0.0007	0.0000	0.0000
0.2033	0.0765	0.0009	0.0000	0.0000
0.2440	0.0754	0.0011	0.0000	0.0000
0.2846	0.0743	0.0014	0.0000	0.0000
0.3253	0.0732	0.0016	0.0000	0.0000
0.3659	0.0721	0.0019	0.0000	0.0000
0.4066	0.0710	0.0022	0.0000	0.0000
0.4473	0.0699	0.0025	0.0000	0.0000
0.4879	0.0688	0.0029	0.0000	0.0000
0.5286	0.0678	0.0032	0.0000	0.0000
0.5692	0.0667	0.0036	0.0000	0.0000
0.6099	0.0656	0.0040	0.0000	0.0000
0.6505	0.0646	0.0044	0.0000	0.0000
0.6912	0.0635	0.0048	0.0000	0.0000



0.7319	0.0624	0.0052	0.0000	0.0000
0.7725	0.0614	0.0057	0.0000	0.0000
0.8132	0.0603	0.0062	0.0000	0.0000
0.8538	0.0593	0.0067	0.0000	0.0000
0.8945	0.0582	0.0072	0.0000	0.0000
0.9352	0.0572	0.0077	0.0000	0.0000
0.9758	0.0561	0.0083	0.0000	0.0000
1.0165	0.0551	0.0088	0.0000	0.0000
1.0571	0.0540	0.0094	0.0000	0.0000
1.0978	0.0530	0.0100	0.0000	0.0000
1.1385	0.0520	0.0106	0.0000	0.0000
1.1791	0.0509	0.0113	0.0030	0.0000
1.2198	0.0499	0.0119	0.0032	0.0000
1.2604	0.0489	0.0126	0.0037	0.0000
1.3011	0.0479	0.0133	0.0042	0.0000
1.3418	0.0468	0.0140	0.0047	0.0000
1.3824	0.0458	0.0147	0.0053	0.0000
1.4231	0.0448	0.0155	0.0060	0.0000
1.4637	0.0438	0.0162	0.0067	0.0000
1.5044	0.0428	0.0170	0.0074	0.0000
1.5451	0.0418	0.0177	0.0082	0.0000
1.5857	0.0408	0.0184	0.0091	0.0000
1.6264	0.0398	0.0192	0.0100	0.0000
1.6670	0.0388	0.0200	0.0109	0.0000
1.7077	0.0378	0.0208	0.0119	0.0000
1.7484	0.0368	0.0216	0.0130	0.0000
1.7890	0.0358	0.0224	0.0141	0.0000
1.8297	0.0348	0.0233	0.0152	0.0000
1.8703	0.0338	0.0241	0.0164	0.0000
1.9110	0.0328	0.0250	0.0177	0.0000
1.9516	0.0319	0.0259	0.0190	0.0000
1.9923	0.0309	0.0269	0.0204	0.0000
2.0330	0.0299	0.0278	0.0217	0.0000
2.0736	0.0289	0.0288	0.0252	0.0000
2.1143	0.0280	0.0297	0.0252	0.0000
2.1549	0.0270	0.0307	0.0252	0.0000
2.1956	0.0260	0.0317	0.0252	0.0000
2.2363	0.0251	0.0328	0.0252	0.0000
2.2769	0.0241	0.0338	0.0252	0.0000
2.3176	0.0232	0.0349	0.0252	0.0000
2.3582	0.0222	0.0359	0.0252	0.0000
2.3989	0.0213	0.0370	0.0252	0.0000
2.4396	0.0203	0.0382	0.0252	0.0000
2.4802	0.0194	0.0393	0.0252	0.0000
2.5209	0.0184	0.0404	0.0252	0.0000
2.5615	0.0175	0.0416	0.0252	0.0000
2.6022	0.0166	0.0428	0.0252	0.0000
2.6429	0.0156	0.0440	0.0252	0.0000
2.6835	0.0147	0.0452	0.0252	0.0000
2.7242	0.0138	0.0465	0.0252	0.0000
2.7648	0.0128	0.0477	0.0252	0.0000
2.8055	0.0119	0.0490	0.0252	0.0000
2.8462	0.0110	0.0503	0.0252	0.0000
2.8868	0.0101	0.0516	0.0252	0.0000
2.9275	0.0092	0.0530	0.0252	0.0000
2.9681	0.0083	0.0543	0.0252	0.0000
3.0000	0.0073	0.0554	0.0252	0.0000



Surface retention 1 Hydraulic Table

Stage(feet)	Area(ac.)	Volume(ac-ft.)	Discharge(cfs)	To Amended(cfs)	Wetted Surface
3.0000	0.0817	0.0554	0.0000	0.0222	0.0000
3.0407	0.0828	0.0588	0.0000	0.0222	0.0000
3.0813	0.0839	0.0621	0.0000	0.0234	0.0000
3.1220	0.0851	0.0656	0.0000	0.0240	0.0000
3.1626	0.0862	0.0691	0.0000	0.0246	0.0000
3.2033	0.0873	0.0726	0.0017	0.0252	0.0000
3.2440	0.0884	0.0762	0.0814	0.0258	0.0000
3.2846	0.0896	0.0798	0.2163	0.0264	0.0000
3.3253	0.0907	0.0834	0.3846	0.0270	0.0000
3.3659	0.0918	0.0872	0.5719	0.0276	0.0000
3.4066	0.0930	0.0909	0.7638	0.0282	0.0000
3.4473	0.0941	0.0947	0.9455	0.0288	0.0000
3.4879	0.0952	0.0986	1.1040	0.0295	0.0000
3.5286	0.0964	0.1025	1.2301	0.0301	0.0000
3.5692	0.0975	0.1064	1.3217	0.0307	0.0000
3.6099	0.0987	0.1104	1.3871	0.0313	0.0000
3.6505	0.0998	0.1144	1.4681	0.0319	0.0000
3.6912	0.1010	0.1185	1.5330	0.0325	0.0000
3.7000	0.1012	0.1194	1.5951	0.0326	0.0000

Name : Surface retention 1

Element Flows To:

Outlet 1 **Outlet 2**
 Bioretention 1

ANALYSIS RESULTS

Stream Protection Duration

Predeveloped Landuse Totals for POC #1

Total Pervious Area:0.714

Total Impervious Area:0

Mitigated Landuse Totals for POC #1

Total Pervious Area:0.174

Total Impervious Area:0.54

Flow Frequency Return Periods for Predeveloped. POC #1

<u>Return Period</u>	<u>Flow(cfs)</u>
2 year	0.015046
5 year	0.023407
10 year	0.02795
25 year	0.032574
50 year	0.035323
100 year	0.037583



Flow Frequency Return Periods for Mitigated. POC #1

<u>Return Period</u>	<u>Flow(cfs)</u>
2 year	0.133086
5 year	0.191791
10 year	0.229281
25 year	0.274827
50 year	0.307426
100 year	0.338928

Stream Protection Duration

Annual Peaks for Predeveloped and Mitigated. POC #1

<u>Year</u>	<u>Predeveloped</u>	<u>Mitigated</u>
-------------	---------------------	------------------

<Omitted to conserve paper>

Stream Protection Duration

Ranked Annual Peaks for Predeveloped and Mitigated. POC #1

<u>Rank</u>	<u>Predeveloped</u>	<u>Mitigated</u>
-------------	---------------------	------------------

<Omitted to conserve paper>

Stream Protection Duration

POC #1

The Facility FAILED

Facility FAILED duration standard for 1+ flows.

Flow(cfs) Predev Mit Percentage Pass/Fail

<Omitted to conserve paper>

The development has an increase in flow durations from 1/2 Predeveloped 2 year flow to the 2 year flow or more than a 10% increase from the 2 year to the 50 year flow. The development has an increase in flow durations for more than 50% of the flows for the range of the duration analysis.

Water Quality BMP Flow and Volume for POC #1

On-line facility volume: 0.0555 acre-feet
 On-line facility target flow: 0.0421 cfs.
 Adjusted for 15 min: 0.0421 cfs.
 Off-line facility target flow: 0.02 cfs.
 Adjusted for 15 min: 0.02 cfs.

LID Report

LID Technique	Used for	Total Volume	Volume	Infiltration	Cumulative
Percent	Water Quality	Percent	Comment	Volume	Volume
Volume	Water Quality	Treatment	Through	(ac-ft.)	Infiltration
Infiltrated	Treated	(ac-ft)	Facility	(ac-ft)	Credit
oretention 1 POC	N	223.48			N
0.00					
Total Volume Infiltrated		223.48	0.00	0.00	
0.00	0.00	0%	No Treat.	Credit	
Compliance with LID Standard 8					
Duration Analysis Result = Failed					



Perlnd and Implnd Changes

No changes have been made.

This program and accompanying documentation are provided 'as-is' without warranty of any kind. The entire risk regarding the performance and results of this program is assumed by End User. Clear Creek Solutions Inc. and the governmental licensee or sublicensees disclaim all warranties, either expressed or implied, including but not limited to implied warranties of program and accompanying documentation. In no event shall Clear Creek Solutions Inc. be liable for any damages whatsoever (including without limitation to damages for loss of business profits, loss of business information, business interruption, and the like) arising out of the use of, or inability to use this program even if Clear Creek Solutions Inc. or their authorized representatives have been advised of the possibility of such damages. Software Copyright © by : Clear Creek Solutions, Inc. 2005-2023; All Rights Reserved.



WWHM2012
PROJECT REPORT

Project Name: Bioretention-2

Site Name:

Site Address:

City :

Report Date: 12/5/2023

Gage : 38 IN CENTRAL

Data Start : 10/01/1901

Data End : 09/30/2059

Precip Scale: 1.00

Version Date: 2023/03/31

Version : 4.2.19

Low Flow Threshold for POC 1 : 50 Percent of the 2 Year

High Flow Threshold for POC 1: 50 year

PREDEVELOPED LAND USE

Name : Basin 1

Bypass: No

GroundWater: No

<u>Pervious Land Use</u>	<u>acre</u>
C, Forest, Flat	2.102

Pervious Total	2.102
----------------	-------

<u>Impervious Land Use</u>	<u>acre</u>
----------------------------	-------------

Impervious Total	0
------------------	---

Basin Total	2.102
-------------	-------

Element Flows To:

Surface	Interflow	Groundwater
---------	-----------	-------------

MITIGATED LAND USE

Name : Basin 2

Bypass: No

GroundWater: No

<u>Pervious Land Use</u>	<u>acre</u>
C, Pasture, Flat	.285

Pervious Total	0.285
----------------	-------



<u>Impervious Land Use</u>	<u>acre</u>
ROADS FLAT	1.817
Impervious Total	1.817
Basin Total	2.102

Element Flows To:

Surface	Interflow	Groundwater
Surface retention 2	Surface retention 2	

Name : Bioretention 2
 Bottom Length: 550.00 ft.
 Bottom Width: 2.00 ft.
 Material thickness of first layer: 1.5
 Material type for first layer: SMMWW 12 in/hr
 Material thickness of second layer: 1.5
 Material type for second layer: GRAVEL
 Material thickness of third layer: 0
 Material type for third layer: GRAVEL
Underdrain used
 Underdrain Diameter (feet): 0.5
 Orifice Diameter (in.): 5.9
 Offset (in.): 6
 Flow Through Underdrain (ac-ft.): 731.033
 Total Outflow (ac-ft.): 791.672
 Percent Through Underdrain: 92.34
Discharge Structure
 Riser Height: 0.2 ft.
 Riser Diameter: 10 in.

Element Flows To:

Outlet 1	Outlet 2
----------	----------

Bioretention 2 Hydraulic Table

Stage(feet)	Area(ac.)	Volume(ac-ft.)	Discharge(cfs)	Infilt(cfs)
0.0000	0.2608	0.0000	0.0000	0.0000
0.0407	0.2582	0.0005	0.0000	0.0000
0.0813	0.2549	0.0011	0.0000	0.0000
0.1220	0.2516	0.0017	0.0000	0.0000
0.1626	0.2483	0.0023	0.0000	0.0000
0.2033	0.2451	0.0031	0.0000	0.0000
0.2440	0.2418	0.0039	0.0000	0.0000
0.2846	0.2385	0.0047	0.0000	0.0000
0.3253	0.2352	0.0056	0.0000	0.0000
0.3659	0.2320	0.0066	0.0000	0.0000
0.4066	0.2287	0.0076	0.0000	0.0000
0.4473	0.2254	0.0087	0.0000	0.0000
0.4879	0.2222	0.0098	0.0000	0.0000
0.5286	0.2189	0.0110	0.0000	0.0000
0.5692	0.2157	0.0122	0.0000	0.0000
0.6099	0.2124	0.0135	0.0000	0.0000
0.6505	0.2092	0.0149	0.0000	0.0000
0.6912	0.2059	0.0163	0.0000	0.0000



0.7319	0.2027	0.0178	0.0000	0.0000
0.7725	0.1994	0.0194	0.0000	0.0000
0.8132	0.1962	0.0210	0.0000	0.0000
0.8538	0.1929	0.0226	0.0000	0.0000
0.8945	0.1897	0.0243	0.0000	0.0000
0.9352	0.1865	0.0261	0.0000	0.0000
0.9758	0.1832	0.0279	0.0000	0.0000
1.0165	0.1800	0.0298	0.0000	0.0000
1.0571	0.1768	0.0318	0.0000	0.0000
1.0978	0.1736	0.0338	0.0000	0.0000
1.1385	0.1704	0.0359	0.0000	0.0000
1.1791	0.1671	0.0380	0.0101	0.0000
1.2198	0.1639	0.0402	0.0109	0.0000
1.2604	0.1607	0.0424	0.0126	0.0000
1.3011	0.1575	0.0447	0.0144	0.0000
1.3418	0.1543	0.0471	0.0163	0.0000
1.3824	0.1511	0.0495	0.0184	0.0000
1.4231	0.1479	0.0520	0.0206	0.0000
1.4637	0.1447	0.0545	0.0230	0.0000
1.5044	0.1415	0.0569	0.0256	0.0000
1.5451	0.1383	0.0593	0.0283	0.0000
1.5857	0.1351	0.0618	0.0312	0.0000
1.6264	0.1319	0.0643	0.0343	0.0000
1.6670	0.1288	0.0669	0.0375	0.0000
1.7077	0.1256	0.0695	0.0410	0.0000
1.7484	0.1224	0.0722	0.0445	0.0000
1.7890	0.1192	0.0749	0.0483	0.0000
1.8297	0.1161	0.0777	0.0523	0.0000
1.8703	0.1129	0.0806	0.0564	0.0000
1.9110	0.1097	0.0835	0.0608	0.0000
1.9516	0.1066	0.0864	0.0653	0.0000
1.9923	0.1034	0.0895	0.0700	0.0000
2.0330	0.1002	0.0925	0.0747	0.0000
2.0736	0.0971	0.0956	0.0866	0.0000
2.1143	0.0939	0.0988	0.0866	0.0000
2.1549	0.0908	0.1020	0.0866	0.0000
2.1956	0.0876	0.1053	0.0866	0.0000
2.2363	0.0845	0.1087	0.0866	0.0000
2.2769	0.0813	0.1121	0.0866	0.0000
2.3176	0.0782	0.1155	0.0866	0.0000
2.3582	0.0751	0.1190	0.0866	0.0000
2.3989	0.0719	0.1226	0.0866	0.0000
2.4396	0.0688	0.1262	0.0866	0.0000
2.4802	0.0657	0.1298	0.0866	0.0000
2.5209	0.0625	0.1336	0.0866	0.0000
2.5615	0.0594	0.1373	0.0866	0.0000
2.6022	0.0563	0.1412	0.0866	0.0000
2.6429	0.0532	0.1450	0.0866	0.0000
2.6835	0.0501	0.1490	0.0866	0.0000
2.7242	0.0470	0.1530	0.0866	0.0000
2.7648	0.0439	0.1570	0.0866	0.0000
2.8055	0.0407	0.1611	0.0866	0.0000
2.8462	0.0376	0.1653	0.0866	0.0000
2.8868	0.0345	0.1695	0.0866	0.0000
2.9275	0.0314	0.1738	0.0866	0.0000
2.9681	0.0283	0.1781	0.0866	0.0000
3.0000	0.0253	0.1816	0.0866	0.0000



Surface retention 2 Hydraulic Table

Stage(feet)	Area(ac.)	Volume(ac-ft.)	Discharge(cfs)	To Amended(cfs)	Wetted Surface
3.0000	0.2608	0.1816	0.0000	0.0764	0.0000
3.0407	0.2641	0.1922	0.0000	0.0764	0.0000
3.0813	0.2674	0.2030	0.0000	0.0805	0.0000
3.1220	0.2707	0.2140	0.0000	0.0826	0.0000
3.1626	0.2740	0.2251	0.0000	0.0847	0.0000
3.2033	0.2773	0.2363	0.0017	0.0867	0.0000
3.2440	0.2806	0.2476	0.0814	0.0888	0.0000
3.2846	0.2839	0.2591	0.2163	0.0909	0.0000
3.3253	0.2872	0.2707	0.3846	0.0930	0.0000
3.3659	0.2905	0.2824	0.5719	0.0950	0.0000
3.4066	0.2939	0.2943	0.7638	0.0971	0.0000
3.4473	0.2972	0.3063	0.9455	0.0992	0.0000
3.4879	0.3005	0.3185	1.1040	0.1012	0.0000
3.5286	0.3038	0.3308	1.2301	0.1033	0.0000
3.5692	0.3072	0.3432	1.3217	0.1054	0.0000
3.6099	0.3105	0.3557	1.3871	0.1074	0.0000
3.6505	0.3138	0.3684	1.4681	0.1095	0.0000
3.6912	0.3172	0.3813	1.5330	0.1116	0.0000
3.7000	0.3179	0.3841	1.5951	0.1120	0.0000

Name : Surface retention 2

Element Flows To:

Outlet 1 **Outlet 2**
 Bioretention 2

ANALYSIS RESULTS

Stream Protection Duration

Predeveloped Landuse Totals for POC #1

Total Pervious Area:2.102

Total Impervious Area:0

Mitigated Landuse Totals for POC #1

Total Pervious Area:0.285

Total Impervious Area:1.817

Flow Frequency Return Periods for Predeveloped. POC #1

<u>Return Period</u>	<u>Flow(cfs)</u>
2 year	0.044295
5 year	0.06891
10 year	0.082285
25 year	0.095898
50 year	0.103989
100 year	0.110643



Flow Frequency Return Periods for Mitigated. POC #1

<u>Return Period</u>	<u>Flow(cfs)</u>
2 year	0.362804
5 year	0.522916
10 year	0.622504
25 year	0.740557
50 year	0.823065
100 year	0.901234

Stream Protection Duration

Annual Peaks for Predeveloped and Mitigated. POC #1

<u>Year</u>	<u>Predeveloped</u>	<u>Mitigated</u>
-------------	---------------------	------------------

<Omitted to conserve paper>

Stream Protection Duration

Ranked Annual Peaks for Predeveloped and Mitigated. POC #1

<u>Rank</u>	<u>Predeveloped</u>	<u>Mitigated</u>
-------------	---------------------	------------------

<Omitted to conserve paper>

Stream Protection Duration

POC #1

The Facility FAILED

Facility FAILED duration standard for 1+ flows.

Flow(cfs) Predev Mit Percentage Pass/Fail

<Omitted to conserve paper>

The development has an increase in flow durations from 1/2 Predeveloped 2 year flow to the 2 year flow or more than a 10% increase from the 2 year to the 50 year flow. The development has an increase in flow durations for more than 50% of the flows for the range of the duration analysis.

Water Quality BMP Flow and Volume for POC #1

On-line facility volume: 0.1815 acre-feet
 On-line facility target flow: 0.1206 cfs.
 Adjusted for 15 min: 0.1206 cfs.
 Off-line facility target flow: 0.0654 cfs.
 Adjusted for 15 min: 0.0654 cfs.

LID Report

LID Technique	Used for	Total Volume	Volume	Infiltration	Cumulative
Percent	Water Quality	Percent	Through	Volume	Volume
Volume	Water Quality	Treatment	Facility	(ac-ft.)	Infiltration
Infiltrated	Treated	(ac-ft)	(ac-ft)		Credit
Retention 2 POC	N	720.42			N
0.00					
Total Volume Infiltrated		720.42	0.00	0.00	
0.00	0.00	0%	No Treat.	Credit	
Compliance with LID Standard 8					
Duration Analysis Result = Failed					



Perlnd and Implnd Changes

No changes have been made.

This program and accompanying documentation are provided 'as-is' without warranty of any kind. The entire risk regarding the performance and results of this program is assumed by End User. Clear Creek Solutions Inc. and the governmental licensee or sublicensees disclaim all warranties, either expressed or implied, including but not limited to implied warranties of program and accompanying documentation. In no event shall Clear Creek Solutions Inc. be liable for any damages whatsoever (including without limitation to damages for loss of business profits, loss of business information, business interruption, and the like) arising out of the use of, or inability to use this program even if Clear Creek Solutions Inc. or their authorized representatives have been advised of the possibility of such damages. Software Copyright © by : Clear Creek Solutions, Inc. 2005-2023; All Rights Reserved.



WWHM2012
PROJECT REPORT

Project Name: Bioretention-3

Site Name:

Site Address:

City :

Report Date: 12/5/2023

Gage : 38 IN CENTRAL

Data Start : 10/01/1901

Data End : 09/30/2059

Precip Scale: 1.00

Version Date: 2023/03/31

Version : 4.2.19

Low Flow Threshold for POC 1 : 50 Percent of the 2 Year

High Flow Threshold for POC 1: 50 year

PREDEVELOPED LAND USE

Name : Basin 3

Bypass: No

GroundWater: No

<u>Pervious Land Use</u>	<u>acre</u>
C, Forest, Flat	.129
Pervious Total	0.129
<u>Impervious Land Use</u>	<u>acre</u>
Impervious Total	0
Basin Total	0.129

Element Flows To:

Surface	Interflow	Groundwater
----------------	------------------	--------------------

MITIGATED LAND USE

Name : Basin 3

Bypass: No

GroundWater: No

<u>Pervious Land Use</u>	<u>acre</u>
C, Pasture, Flat	.009
Pervious Total	0.009



<u>Impervious Land Use</u>	<u>acre</u>
ROADS FLAT	0.12
Impervious Total	0.12
Basin Total	0.129

Element Flows To:

Surface	Interflow	Groundwater
Surface retention 3	Surface retention 3	

Name : Bioretention 3
 Bottom Length: 45.00 ft.
 Bottom Width: 2.00 ft.
 Material thickness of first layer: 1.5
 Material type for first layer: SMMWW 12 in/hr
 Material thickness of second layer: 1.5
 Material type for second layer: GRAVEL
 Material thickness of third layer: 0
 Material type for third layer: GRAVEL
Underdrain used
 Underdrain Diameter (feet): 0.5
 Orifice Diameter (in.): 5.9
 Offset (in.): 6
 Flow Through Underdrain (ac-ft.): 50.407
 Total Outflow (ac-ft.): 52.936
 Percent Through Underdrain: 95.22
Discharge Structure
 Riser Height: 0.2 ft.
 Riser Diameter: 10 in.

Element Flows To:

Outlet 1	Outlet 2
----------	----------

Bioretention 3 Hydraulic Table

Stage(feet)	Area(ac.)	Volume(ac-ft.)	Discharge(cfs)	Infilt(cfs)
0.0000	0.028926	0.000000	0.0000	0.0000
0.0407	0.028562	0.000041	0.0000	0.0000
0.0813	0.028101	0.000087	0.0000	0.0000
0.1220	0.027642	0.000138	0.0000	0.0000
0.1626	0.027186	0.000193	0.0000	0.0000
0.2033	0.026733	0.000254	0.0000	0.0000
0.2440	0.026283	0.000320	0.0000	0.0000
0.2846	0.025835	0.000392	0.0000	0.0000
0.3253	0.025390	0.000468	0.0000	0.0000
0.3659	0.024948	0.000550	0.0000	0.0000
0.4066	0.024509	0.000637	0.0000	0.0000
0.4473	0.024072	0.000730	0.0000	0.0000
0.4879	0.023638	0.000828	0.0000	0.0000
0.5286	0.023207	0.000932	0.0000	0.0000
0.5692	0.022778	0.001041	0.0000	0.0000
0.6099	0.022352	0.001155	0.0000	0.0000
0.6505	0.021929	0.001276	0.0000	0.0000
0.6912	0.021509	0.001402	0.0000	0.0000

0.7319	0.021091	0.001534	0.0000	0.0000
0.7725	0.020676	0.001671	0.0000	0.0000
0.8132	0.020264	0.001815	0.0000	0.0000
0.8538	0.019855	0.001964	0.0000	0.0000
0.8945	0.019448	0.002120	0.0000	0.0000
0.9352	0.019044	0.002281	0.0000	0.0000
0.9758	0.018643	0.002449	0.0000	0.0000
1.0165	0.018244	0.002622	0.0000	0.0000
1.0571	0.017849	0.002802	0.0000	0.0000
1.0978	0.017456	0.002988	0.0000	0.0000
1.1385	0.017065	0.003180	0.0000	0.0000
1.1791	0.016678	0.003379	0.0008	0.0000
1.2198	0.016293	0.003584	0.0009	0.0000
1.2604	0.015911	0.003795	0.0010	0.0000
1.3011	0.015532	0.004013	0.0012	0.0000
1.3418	0.015155	0.004237	0.0013	0.0000
1.3824	0.014781	0.004468	0.0015	0.0000
1.4231	0.014410	0.004705	0.0017	0.0000
1.4637	0.014041	0.004950	0.0019	0.0000
1.5044	0.013676	0.005177	0.0021	0.0000
1.5451	0.013313	0.005411	0.0023	0.0000
1.5857	0.012953	0.005651	0.0026	0.0000
1.6264	0.012595	0.005898	0.0028	0.0000
1.6670	0.012240	0.006150	0.0031	0.0000
1.7077	0.011888	0.006409	0.0034	0.0000
1.7484	0.011539	0.006674	0.0036	0.0000
1.7890	0.011192	0.006946	0.0040	0.0000
1.8297	0.010849	0.007224	0.0043	0.0000
1.8703	0.010507	0.007509	0.0046	0.0000
1.9110	0.010169	0.007800	0.0050	0.0000
1.9516	0.009833	0.008098	0.0053	0.0000
1.9923	0.009501	0.008402	0.0057	0.0000
2.0330	0.009170	0.008714	0.0061	0.0000
2.0736	0.008843	0.009032	0.0071	0.0000
2.1143	0.008518	0.009356	0.0071	0.0000
2.1549	0.008196	0.009688	0.0071	0.0000
2.1956	0.007877	0.010026	0.0071	0.0000
2.2363	0.007561	0.010372	0.0071	0.0000
2.2769	0.007247	0.010724	0.0071	0.0000
2.3176	0.006936	0.011084	0.0071	0.0000
2.3582	0.006627	0.011450	0.0071	0.0000
2.3989	0.006322	0.011824	0.0071	0.0000
2.4396	0.006019	0.012204	0.0071	0.0000
2.4802	0.005719	0.012592	0.0071	0.0000
2.5209	0.005422	0.012988	0.0071	0.0000
2.5615	0.005127	0.013390	0.0071	0.0000
2.6022	0.004835	0.013800	0.0071	0.0000
2.6429	0.004546	0.014217	0.0071	0.0000
2.6835	0.004259	0.014642	0.0071	0.0000
2.7242	0.003976	0.015074	0.0071	0.0000
2.7648	0.003695	0.015514	0.0071	0.0000
2.8055	0.003416	0.015961	0.0071	0.0000
2.8462	0.003141	0.016416	0.0071	0.0000
2.8868	0.002868	0.016879	0.0071	0.0000
2.9275	0.002598	0.017349	0.0071	0.0000
2.9681	0.002331	0.017827	0.0071	0.0000
3.0000	0.002066	0.018207	0.0071	0.0000



Surface retention 3 Hydraulic Table

<u>Stage(feet)</u>	<u>Area(ac.)</u>	<u>Volume(ac-ft.)</u>	<u>Discharge(cfs)</u>	<u>To Amended(cfs)</u>	<u>Wetted Surface</u>
3.0000	0.028926	0.018207	0.0000	0.0063	0.0000
3.0407	0.029392	0.019393	0.0000	0.0063	0.0000
3.0813	0.029861	0.020597	0.0000	0.0066	0.0000
3.1220	0.030332	0.021821	0.0000	0.0068	0.0000
3.1626	0.030807	0.023064	0.0000	0.0069	0.0000
3.2033	0.031284	0.024326	0.0017	0.0071	0.0000
3.2440	0.031764	0.025608	0.0814	0.0073	0.0000
3.2846	0.032246	0.026909	0.2163	0.0074	0.0000
3.3253	0.032732	0.028230	0.3846	0.0076	0.0000
3.3659	0.033220	0.029571	0.5719	0.0078	0.0000
3.4066	0.033711	0.030932	0.7638	0.0079	0.0000
3.4473	0.034204	0.032312	0.9455	0.0081	0.0000
3.4879	0.034700	0.033713	1.1040	0.0083	0.0000
3.5286	0.035199	0.035134	1.2301	0.0085	0.0000
3.5692	0.035701	0.036576	1.3217	0.0086	0.0000
3.6099	0.036206	0.038037	1.3871	0.0088	0.0000
3.6505	0.036713	0.039520	1.4681	0.0090	0.0000
3.6912	0.037223	0.041023	1.5330	0.0091	0.0000
3.7000	0.037333	0.041351	1.5951	0.0092	0.0000

Name : Surface retention 3

Element Flows To:

Outlet 1 **Outlet 2**
 Bioretention 3

ANALYSIS RESULTS

Stream Protection Duration

Predeveloped Landuse Totals for POC #1

Total Pervious Area:0.129

Total Impervious Area:0

Mitigated Landuse Totals for POC #1

Total Pervious Area:0.009

Total Impervious Area:0.12

Flow Frequency Return Periods for Predeveloped. POC #1

<u>Return Period</u>	<u>Flow(cfs)</u>
2 year	0.002718
5 year	0.004229
10 year	0.00505
25 year	0.005885
50 year	0.006382
100 year	0.00679



Flow Frequency Return Periods for Mitigated. POC #1

<u>Return Period</u>	<u>Flow(cfs)</u>
2 year	0.027743
5 year	0.045471
10 year	0.056524
25 year	0.06927
50 year	0.077826
100 year	0.085607

Stream Protection Duration

Annual Peaks for Predeveloped and Mitigated. POC #1

Year Predeveloped Mitigated

<Omitted to conserve paper>

Stream Protection Duration

Ranked Annual Peaks for Predeveloped and Mitigated. POC #1

Rank Predeveloped Mitigated

<Omitted to conserve paper>

Stream Protection Duration

POC #1

The Facility FAILED

Facility FAILED duration standard for 1+ flows.

Flow(cfs) Predev Mit Percentage Pass/Fail

<Omitted to conserve paper>

The development has an increase in flow durations from 1/2 Predeveloped 2 year flow to the 2 year flow or more than a 10% increase from the 2 year to the 50 year flow. The development has an increase in flow durations for more than 50% of the flows for the range of the duration analysis.

Water Quality BMP Flow and Volume for POC #1

On-line facility volume: 0.0118 acre-feet
 On-line facility target flow: 0.0065 cfs.
 Adjusted for 15 min: 0.0065 cfs.
 Off-line facility target flow: 0.0042 cfs.
 Adjusted for 15 min: 0.0042 cfs.

LID Report

LID Technique	Used for	Total Volume	Volume	Infiltration	Cumulative	
Percent	Water Quality	Percent	Comment	Volume	Volume	
Volume		Treatment?	Needs	Through		
Infiltrated	Treated	Water Quality	Treatment	Facility	(ac-ft.)	Infiltration
			(ac-ft)	(ac-ft)		Credit
oretention 3 POC		N	48.17			N
0.00						
Total Volume Infiltrated			48.17	0.00	0.00	
0.00	0.00	0%	No Treat.			
Compliance with LID Standard 8						
Duration Analysis Result = Failed						



Perlnd and Implnd Changes

No changes have been made.

This program and accompanying documentation are provided 'as-is' without warranty of any kind. The entire risk regarding the performance and results of this program is assumed by End User. Clear Creek Solutions Inc. and the governmental licensee or sublicensees disclaim all warranties, either expressed or implied, including but not limited to implied warranties of program and accompanying documentation. In no event shall Clear Creek Solutions Inc. be liable for any damages whatsoever (including without limitation to damages for loss of business profits, loss of business information, business interruption, and the like) arising out of the use of, or inability to use this program even if Clear Creek Solutions Inc. or their authorized representatives have been advised of the possibility of such damages. Software Copyright © by : Clear Creek Solutions, Inc. 2005-2023; All Rights Reserved.



General Model Information

WWHM2012 Project Name: Hydroperiod

Site Name: PSE OTC
Site Address: Todd Road
City: Puyallup
Report Date: 12/5/2023
Gage: 38 IN CENTRAL
Data Start: 10/01/1901
Data End: 09/30/2059
Timestep: 15 Minute
Precip Scale: 1.000
Version Date: 2023/03/31
Version: 4.2.19

POC Thresholds

Low Flow Threshold for POC1:	50 Percent of the 2 Year
High Flow Threshold for POC1:	50 Year

Landuse Basin Data

Predeveloped Land Use

On-site Pre

Bypass:	No
GroundWater:	No
Pervious Land Use C, Lawn, Flat	acre 3.119
Pervious Total	3.119
Impervious Land Use PARKING FLAT	acre 1.97
Impervious Total	1.97
Basin Total	5.089

Off-Site Property

Bypass:	No
GroundWater:	No
Pervious Land Use C, Lawn, Flat	acre 0.62
Pervious Total	0.62
Impervious Land Use PARKING FLAT	acre 3.15
Impervious Total	3.15
Basin Total	3.77

Off-Site Flow

Bypass:	No
GroundWater:	No
Pervious Land Use C, Lawn, Flat	acre 4.28
Pervious Total	4.28
Impervious Land Use ROADS FLAT	acre 1.5
Impervious Total	1.5
Basin Total	5.78

Mitigated Land Use

On-site Post

Bypass:	No
GroundWater:	No
Pervious Land Use	acre
C, Pasture, Flat	1.022
Pervious Total	1.022
Impervious Land Use	acre
ROADS FLAT	2.506
ROOF TOPS FLAT	0.987
POND	0.574
Impervious Total	4.067
Basin Total	5.089

Off-site Flow

Bypass:	Yes
GroundWater:	No
Pervious Land Use C, Lawn, Flat	acre 4.28
Pervious Total	4.28
Impervious Land Use ROADS FLAT	acre 1.5
Impervious Total	1.5
Basin Total	5.78

Off-Site Property

Bypass:	Yes
GroundWater:	No
Pervious Land Use C, Lawn, Flat	acre 0.62
Pervious Total	0.62
Impervious Land Use PARKING FLAT	acre 3.15
Impervious Total	3.15
Basin Total	3.77

Routing Elements

Predeveloped Routing

Trapezoidal Pond 1

Bottom Length: 109.50 ft.
Bottom Width: 36.50 ft.
Depth: 7.5 ft.
Volume at riser head: 1.1184 acre-feet.
Side slope 1: 3 To 1
Side slope 2: 3 To 1
Side slope 3: 3 To 1
Side slope 4: 3 To 1
Discharge Structure
Riser Height: 6.5 ft.
Riser Diameter: 18 in.
Orifice 1 Diameter: 1.150 in. Elevation:0 ft.
Orifice 2 Diameter: 1.900 in. Elevation:3.6355 ft.
Orifice 3 Diameter: 1.150 in. Elevation:4.175 ft.
Element Flows To:
Outlet 1 Outlet 2

Pond Hydraulic Table

Stage(feet)	Area(ac.)	Volume(ac-ft.)	Discharge(cfs)	Infilt(cfs)
0.0000	0.091	0.000	0.000	0.000
0.0833	0.093	0.007	0.010	0.000
0.1667	0.095	0.015	0.014	0.000
0.2500	0.096	0.023	0.017	0.000
0.3333	0.098	0.031	0.020	0.000
0.4167	0.100	0.040	0.023	0.000
0.5000	0.102	0.048	0.025	0.000
0.5833	0.103	0.057	0.027	0.000
0.6667	0.105	0.065	0.029	0.000
0.7500	0.107	0.074	0.031	0.000
0.8333	0.109	0.083	0.032	0.000
0.9167	0.110	0.092	0.034	0.000
1.0000	0.112	0.102	0.035	0.000
1.0833	0.114	0.111	0.037	0.000
1.1667	0.116	0.121	0.038	0.000
1.2500	0.118	0.130	0.040	0.000
1.3333	0.120	0.140	0.041	0.000
1.4167	0.121	0.150	0.042	0.000
1.5000	0.123	0.161	0.044	0.000
1.5833	0.125	0.171	0.045	0.000
1.6667	0.127	0.182	0.046	0.000
1.7500	0.129	0.192	0.047	0.000
1.8333	0.131	0.203	0.048	0.000
1.9167	0.133	0.214	0.049	0.000
2.0000	0.135	0.225	0.050	0.000
2.0833	0.137	0.237	0.051	0.000
2.1667	0.139	0.248	0.052	0.000
2.2500	0.141	0.260	0.053	0.000
2.3333	0.143	0.272	0.054	0.000
2.4167	0.145	0.284	0.055	0.000
2.5000	0.147	0.296	0.056	0.000

2.5833	0.149	0.308	0.057	0.000
2.6667	0.151	0.321	0.058	0.000
2.7500	0.153	0.334	0.059	0.000
2.8333	0.155	0.347	0.060	0.000
2.9167	0.157	0.360	0.061	0.000
3.0000	0.159	0.373	0.062	0.000
3.0833	0.161	0.386	0.063	0.000
3.1667	0.163	0.400	0.063	0.000
3.2500	0.165	0.413	0.064	0.000
3.3333	0.168	0.427	0.065	0.000
3.4167	0.170	0.441	0.066	0.000
3.5000	0.172	0.456	0.067	0.000
3.5833	0.174	0.470	0.067	0.000
3.6667	0.176	0.485	0.086	0.000
3.7500	0.178	0.500	0.102	0.000
3.8333	0.181	0.515	0.113	0.000
3.9167	0.183	0.530	0.123	0.000
4.0000	0.185	0.545	0.130	0.000
4.0833	0.187	0.561	0.138	0.000
4.1667	0.189	0.576	0.144	0.000
4.2500	0.192	0.592	0.160	0.000
4.3333	0.194	0.608	0.170	0.000
4.4167	0.196	0.625	0.179	0.000
4.5000	0.199	0.641	0.187	0.000
4.5833	0.201	0.658	0.195	0.000
4.6667	0.203	0.675	0.202	0.000
4.7500	0.205	0.692	0.208	0.000
4.8333	0.208	0.709	0.215	0.000
4.9167	0.210	0.726	0.221	0.000
5.0000	0.213	0.744	0.227	0.000
5.0833	0.215	0.762	0.233	0.000
5.1667	0.217	0.780	0.238	0.000
5.2500	0.220	0.798	0.243	0.000
5.3333	0.222	0.817	0.249	0.000
5.4167	0.224	0.835	0.254	0.000
5.5000	0.227	0.854	0.259	0.000
5.5833	0.229	0.873	0.264	0.000
5.6667	0.232	0.892	0.268	0.000
5.7500	0.234	0.912	0.273	0.000
5.8333	0.237	0.932	0.278	0.000
5.9167	0.239	0.951	0.282	0.000
6.0000	0.242	0.972	0.287	0.000
6.0833	0.244	0.992	0.291	0.000
6.1667	0.247	1.012	0.295	0.000
6.2500	0.249	1.033	0.299	0.000
6.3333	0.252	1.054	0.303	0.000
6.4167	0.254	1.075	0.308	0.000
6.5000	0.257	1.096	0.312	0.000
6.5833	0.260	1.118	0.698	0.000
6.6667	0.262	1.140	1.394	0.000
6.7500	0.265	1.162	2.262	0.000
6.8333	0.267	1.184	3.210	0.000
6.9167	0.270	1.206	4.143	0.000
7.0000	0.273	1.229	4.974	0.000
7.0833	0.275	1.252	5.632	0.000
7.1667	0.278	1.275	6.096	0.000
7.2500	0.281	1.298	6.417	0.000
7.3333	0.283	1.322	6.818	0.000

7.4167	0.286	1.346	7.137	0.000
7.5000	0.289	1.370	7.443	0.000
7.5833	0.291	1.394	7.735	0.000

Mitigated Routing

Vault 1

Width: 147 ft.
Length: 147 ft.
Depth: 4.3 ft.
Discharge Structure
Riser Height: 3.3 ft.
Riser Diameter: 18 in.
Notch Type: Rectangular
Notch Width: 0.042 ft.
Notch Height: 1.500 ft.
Orifice 1 Diameter: 1.520 in. Elevation:0 ft.
Element Flows To:
Outlet 1 Outlet 2

Vault Hydraulic Table

Stage(feet)	Area(ac.)	Volume(ac-ft.)	Discharge(cfs)	Infilt(cfs)
0.0000	0.496	0.000	0.000	0.000
0.0478	0.496	0.023	0.013	0.000
0.0956	0.496	0.047	0.019	0.000
0.1433	0.496	0.071	0.023	0.000
0.1911	0.496	0.094	0.027	0.000
0.2389	0.496	0.118	0.030	0.000
0.2867	0.496	0.142	0.033	0.000
0.3344	0.496	0.165	0.036	0.000
0.3822	0.496	0.189	0.038	0.000
0.4300	0.496	0.213	0.041	0.000
0.4778	0.496	0.237	0.043	0.000
0.5256	0.496	0.260	0.045	0.000
0.5733	0.496	0.284	0.047	0.000
0.6211	0.496	0.308	0.049	0.000
0.6689	0.496	0.331	0.051	0.000
0.7167	0.496	0.355	0.053	0.000
0.7644	0.496	0.379	0.054	0.000
0.8122	0.496	0.402	0.056	0.000
0.8600	0.496	0.426	0.058	0.000
0.9078	0.496	0.450	0.059	0.000
0.9556	0.496	0.474	0.061	0.000
1.0033	0.496	0.497	0.062	0.000
1.0511	0.496	0.521	0.064	0.000
1.0989	0.496	0.545	0.065	0.000
1.1467	0.496	0.568	0.067	0.000
1.1944	0.496	0.592	0.068	0.000
1.2422	0.496	0.616	0.069	0.000
1.2900	0.496	0.639	0.071	0.000
1.3378	0.496	0.663	0.072	0.000
1.3856	0.496	0.687	0.073	0.000
1.4333	0.496	0.711	0.075	0.000
1.4811	0.496	0.734	0.076	0.000
1.5289	0.496	0.758	0.077	0.000
1.5767	0.496	0.782	0.078	0.000
1.6244	0.496	0.805	0.079	0.000
1.6722	0.496	0.829	0.081	0.000
1.7200	0.496	0.853	0.082	0.000

1.7678	0.496	0.876	0.083	0.000
1.8156	0.496	0.900	0.084	0.000
1.8633	0.496	0.924	0.087	0.000
1.9111	0.496	0.948	0.091	0.000
1.9589	0.496	0.971	0.096	0.000
2.0067	0.496	0.995	0.101	0.000
2.0544	0.496	1.019	0.106	0.000
2.1022	0.496	1.042	0.112	0.000
2.1500	0.496	1.066	0.118	0.000
2.1978	0.496	1.090	0.125	0.000
2.2456	0.496	1.114	0.131	0.000
2.2933	0.496	1.137	0.138	0.000
2.3411	0.496	1.161	0.145	0.000
2.3889	0.496	1.185	0.152	0.000
2.4367	0.496	1.208	0.159	0.000
2.4844	0.496	1.232	0.166	0.000
2.5322	0.496	1.256	0.174	0.000
2.5800	0.496	1.279	0.181	0.000
2.6278	0.496	1.303	0.188	0.000
2.6756	0.496	1.327	0.196	0.000
2.7233	0.496	1.351	0.203	0.000
2.7711	0.496	1.374	0.211	0.000
2.8189	0.496	1.398	0.219	0.000
2.8667	0.496	1.422	0.228	0.000
2.9144	0.496	1.445	0.237	0.000
2.9622	0.496	1.469	0.247	0.000
3.0100	0.496	1.493	0.256	0.000
3.0578	0.496	1.516	0.266	0.000
3.1056	0.496	1.540	0.276	0.000
3.1533	0.496	1.564	0.286	0.000
3.2011	0.496	1.588	0.355	0.000
3.2489	0.496	1.611	0.368	0.000
3.2967	0.496	1.635	0.382	0.000
3.3444	0.496	1.659	0.533	0.000
3.3922	0.496	1.682	0.829	0.000
3.4400	0.496	1.706	1.215	0.000
3.4878	0.496	1.730	1.666	0.000
3.5356	0.496	1.753	2.167	0.000
3.5833	0.496	1.777	2.699	0.000
3.6311	0.496	1.801	3.245	0.000
3.6789	0.496	1.825	3.788	0.000
3.7267	0.496	1.848	4.309	0.000
3.7744	0.496	1.872	4.792	0.000
3.8222	0.496	1.896	5.224	0.000
3.8700	0.496	1.919	5.594	0.000
3.9178	0.496	1.943	5.900	0.000
3.9656	0.496	1.967	6.143	0.000
4.0133	0.496	1.990	6.337	0.000
4.0611	0.496	2.014	6.578	0.000
4.1089	0.496	2.038	6.770	0.000
4.1567	0.496	2.062	6.956	0.000
4.2044	0.496	2.085	7.137	0.000
4.2522	0.496	2.109	7.313	0.000
4.3000	0.496	2.133	7.485	0.000
4.3478	0.496	2.156	7.654	0.000
4.3956	0.000	0.000	7.818	0.000

Trapezoidal Pond 1

Bottom Length: 109.50 ft.
 Bottom Width: 36.50 ft.
 Depth: 7.5 ft.
 Volume at riser head: 1.1184 acre-feet.
 Side slope 1: 3 To 1
 Side slope 2: 3 To 1
 Side slope 3: 3 To 1
 Side slope 4: 3 To 1
 Discharge Structure
 Riser Height: 6.5 ft.
 Riser Diameter: 18 in.
 Orifice 1 Diameter: 1.150 in. Elevation:0 ft.
 Orifice 2 Diameter: 1.900 in. Elevation:3.6355 ft.
 Orifice 3 Diameter: 1.150 in. Elevation:4.175 ft.
 Element Flows To:
 Outlet 1 Outlet 2

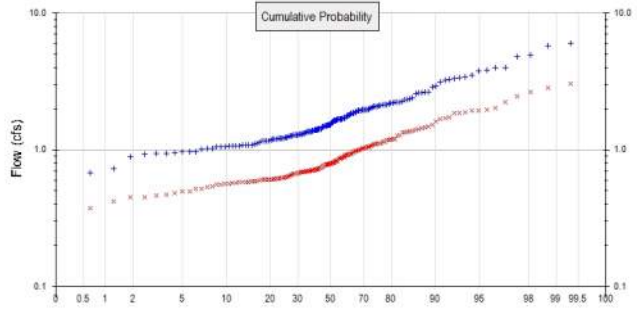
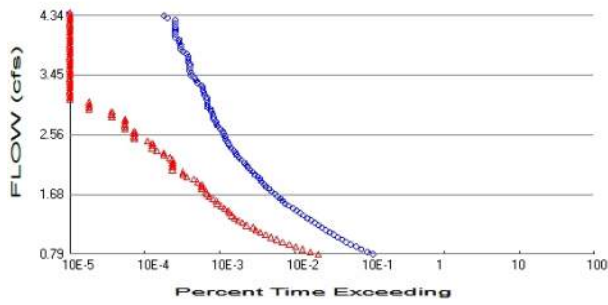
Pond Hydraulic Table

Stage(feet)	Area(ac.)	Volume(ac-ft.)	Discharge(cfs)	Infilt(cfs)
0.0000	0.091	0.000	0.000	0.000
0.0833	0.093	0.007	0.010	0.000
0.1667	0.095	0.015	0.014	0.000
0.2500	0.096	0.023	0.017	0.000
0.3333	0.098	0.031	0.020	0.000
0.4167	0.100	0.040	0.023	0.000
0.5000	0.102	0.048	0.025	0.000
0.5833	0.103	0.057	0.027	0.000
0.6667	0.105	0.065	0.029	0.000
0.7500	0.107	0.074	0.031	0.000
0.8333	0.109	0.083	0.032	0.000
0.9167	0.110	0.092	0.034	0.000
1.0000	0.112	0.102	0.035	0.000
1.0833	0.114	0.111	0.037	0.000
1.1667	0.116	0.121	0.038	0.000
1.2500	0.118	0.130	0.040	0.000
1.3333	0.120	0.140	0.041	0.000
1.4167	0.121	0.150	0.042	0.000
1.5000	0.123	0.161	0.044	0.000
1.5833	0.125	0.171	0.045	0.000
1.6667	0.127	0.182	0.046	0.000
1.7500	0.129	0.192	0.047	0.000
1.8333	0.131	0.203	0.048	0.000
1.9167	0.133	0.214	0.049	0.000
2.0000	0.135	0.225	0.050	0.000
2.0833	0.137	0.237	0.051	0.000
2.1667	0.139	0.248	0.052	0.000
2.2500	0.141	0.260	0.053	0.000
2.3333	0.143	0.272	0.054	0.000
2.4167	0.145	0.284	0.055	0.000
2.5000	0.147	0.296	0.056	0.000
2.5833	0.149	0.308	0.057	0.000
2.6667	0.151	0.321	0.058	0.000
2.7500	0.153	0.334	0.059	0.000
2.8333	0.155	0.347	0.060	0.000

2.9167	0.157	0.360	0.061	0.000
3.0000	0.159	0.373	0.062	0.000
3.0833	0.161	0.386	0.063	0.000
3.1667	0.163	0.400	0.063	0.000
3.2500	0.165	0.413	0.064	0.000
3.3333	0.168	0.427	0.065	0.000
3.4167	0.170	0.441	0.066	0.000
3.5000	0.172	0.456	0.067	0.000
3.5833	0.174	0.470	0.067	0.000
3.6667	0.176	0.485	0.086	0.000
3.7500	0.178	0.500	0.102	0.000
3.8333	0.181	0.515	0.113	0.000
3.9167	0.183	0.530	0.123	0.000
4.0000	0.185	0.545	0.130	0.000
4.0833	0.187	0.561	0.138	0.000
4.1667	0.189	0.576	0.144	0.000
4.2500	0.192	0.592	0.160	0.000
4.3333	0.194	0.608	0.170	0.000
4.4167	0.196	0.625	0.179	0.000
4.5000	0.199	0.641	0.187	0.000
4.5833	0.201	0.658	0.195	0.000
4.6667	0.203	0.675	0.202	0.000
4.7500	0.205	0.692	0.208	0.000
4.8333	0.208	0.709	0.215	0.000
4.9167	0.210	0.726	0.221	0.000
5.0000	0.213	0.744	0.227	0.000
5.0833	0.215	0.762	0.233	0.000
5.1667	0.217	0.780	0.238	0.000
5.2500	0.220	0.798	0.243	0.000
5.3333	0.222	0.817	0.249	0.000
5.4167	0.224	0.835	0.254	0.000
5.5000	0.227	0.854	0.259	0.000
5.5833	0.229	0.873	0.264	0.000
5.6667	0.232	0.892	0.268	0.000
5.7500	0.234	0.912	0.273	0.000
5.8333	0.237	0.932	0.278	0.000
5.9167	0.239	0.951	0.282	0.000
6.0000	0.242	0.972	0.287	0.000
6.0833	0.244	0.992	0.291	0.000
6.1667	0.247	1.012	0.295	0.000
6.2500	0.249	1.033	0.299	0.000
6.3333	0.252	1.054	0.303	0.000
6.4167	0.254	1.075	0.308	0.000
6.5000	0.257	1.096	0.312	0.000
6.5833	0.260	1.118	0.698	0.000
6.6667	0.262	1.140	1.394	0.000
6.7500	0.265	1.162	2.262	0.000
6.8333	0.267	1.184	3.210	0.000
6.9167	0.270	1.206	4.143	0.000
7.0000	0.273	1.229	4.974	0.000
7.0833	0.275	1.252	5.632	0.000
7.1667	0.278	1.275	6.096	0.000
7.2500	0.281	1.298	6.417	0.000
7.3333	0.283	1.322	6.818	0.000
7.4167	0.286	1.346	7.137	0.000
7.5000	0.289	1.370	7.443	0.000
7.5833	0.291	1.394	7.735	0.000

Analysis Results

POC 1



+ Predeveloped x Mitigated

Predeveloped Landuse Totals for POC #1

Total Pervious Area: 8.019
 Total Impervious Area: 6.62

Mitigated Landuse Totals for POC #1

Total Pervious Area: 5.922
 Total Impervious Area: 8.717

Flow Frequency Method: Log Pearson Type III 17B

Flow Frequency Return Periods for Predeveloped. POC #1

Return Period	Flow(cfs)
2 year	1.575154
5 year	2.281503
10 year	2.837291
25 year	3.64894
50 year	4.339132
100 year	5.107993

Flow Frequency Return Periods for Mitigated. POC #1

Return Period	Flow(cfs)
2 year	0.826068
5 year	1.206547
10 year	1.507869
25 year	1.950257
50 year	2.328228
100 year	2.75088

Annual Peaks

Annual Peaks for Predeveloped and Mitigated. POC #1

Year	Predeveloped	Mitigated
1902	1.493	0.704
1903	1.671	0.792
1904	3.138	1.617
1905	1.007	0.577
1906	0.955	0.464
1907	1.955	1.070
1908	1.300	0.674
1909	1.353	0.717
1910	1.930	1.045
1911	1.818	0.910

1912	4.950	2.629
1913	1.048	0.737
1914	5.805	2.827
1915	1.067	0.591
1916	1.625	0.798
1917	0.675	0.374
1918	1.282	0.626
1919	1.016	0.561
1920	1.508	0.801
1921	1.333	0.783
1922	2.243	1.183
1923	1.362	0.723
1924	1.859	0.860
1925	0.968	0.530
1926	1.488	0.700
1927	1.236	0.580
1928	1.172	0.636
1929	2.385	1.202
1930	1.954	0.926
1931	1.123	0.605
1932	1.255	0.663
1933	1.288	0.716
1934	2.646	1.388
1935	0.936	0.572
1936	1.474	0.768
1937	2.118	1.138
1938	1.089	0.603
1939	1.164	0.612
1940	1.912	0.880
1941	1.857	0.849
1942	2.111	1.120
1943	1.720	0.876
1944	2.929	1.686
1945	1.690	0.825
1946	1.718	0.891
1947	1.029	0.537
1948	1.688	0.978
1949	1.981	1.179
1950	1.089	0.496
1951	1.637	0.734
1952	4.007	2.236
1953	3.352	1.843
1954	1.297	0.682
1955	0.970	0.481
1956	0.939	0.446
1957	1.191	0.607
1958	2.330	1.421
1959	2.206	1.337
1960	1.094	0.556
1961	3.821	1.887
1962	1.418	0.696
1963	0.922	0.452
1964	3.991	2.012
1965	1.687	0.914
1966	1.198	0.616
1967	2.139	1.102
1968	1.405	0.684
1969	1.360	0.708

1970	1.808	0.945
1971	1.871	1.016
1972	5.992	3.054
1973	2.231	1.193
1974	2.021	0.991
1975	3.416	1.945
1976	2.869	1.473
1977	0.882	0.468
1978	2.329	1.272
1979	1.713	0.864
1980	2.086	1.095
1981	1.423	0.705
1982	1.211	0.629
1983	1.958	1.042
1984	1.945	1.015
1985	2.583	1.351
1986	1.112	0.632
1987	2.193	1.354
1988	1.154	0.670
1989	1.052	0.592
1990	1.371	0.728
1991	2.065	1.056
1992	1.687	0.961
1993	1.653	0.775
1994	1.765	0.958
1995	1.089	0.605
1996	1.953	1.285
1997	1.312	0.675
1998	1.846	0.980
1999	1.349	0.624
2000	1.517	0.796
2001	1.069	0.565
2002	3.265	1.739
2003	1.406	0.826
2004	1.782	0.936
2005	3.504	1.865
2006	1.402	0.667
2007	1.932	0.987
2008	1.425	0.690
2009	1.076	0.578
2010	1.450	0.754
2011	1.277	0.584
2012	1.483	0.765
2013	1.601	0.815
2014	1.219	0.617
2015	3.310	1.707
2016	1.165	0.588
2017	2.150	1.118
2018	2.227	1.524
2019	3.215	1.957
2020	1.973	1.027
2021	1.624	0.932
2022	2.169	1.036
2023	2.356	1.083
2024	4.793	2.476
2025	1.220	0.570
2026	1.417	0.875
2027	1.523	0.717

2028	0.620	0.366
2029	1.320	0.697
2030	2.042	1.138
2031	0.732	0.416
2032	1.045	0.495
2033	1.294	0.605
2034	1.068	0.521
2035	2.259	1.459
2036	1.220	0.704
2037	1.368	0.652
2038	2.084	1.109
2039	2.613	1.200
2040	1.269	0.670
2041	1.584	0.799
2042	2.128	1.379
2043	1.657	0.918
2044	1.502	0.828
2045	1.165	0.608
2046	1.279	0.750
2047	1.269	0.610
2048	1.074	0.552
2049	1.566	0.781
2050	1.531	0.793
2051	2.650	1.440
2052	1.233	0.582
2053	1.194	0.764
2054	3.758	1.932
2055	1.389	0.687
2056	1.693	0.782
2057	0.968	0.517
2058	1.527	0.701
2059	2.598	1.344

Ranked Annual Peaks

Ranked Annual Peaks for Predeveloped and Mitigated. POC #1

Rank	Predeveloped	Mitigated
1	5.9918	3.0541
2	5.8048	2.8275
3	4.9502	2.6290
4	4.7932	2.4758
5	4.0072	2.2356
6	3.9911	2.0120
7	3.8207	1.9569
8	3.7583	1.9452
9	3.5040	1.9321
10	3.4165	1.8866
11	3.3517	1.8647
12	3.3104	1.8430
13	3.2653	1.7387
14	3.2148	1.7068
15	3.1382	1.6858
16	2.9290	1.6168
17	2.8688	1.5244
18	2.6499	1.4732
19	2.6463	1.4587
20	2.6131	1.4405
21	2.5976	1.4212
22	2.5828	1.3876

23	2.3851	1.3787
24	2.3564	1.3539
25	2.3296	1.3512
26	2.3288	1.3441
27	2.2594	1.3370
28	2.2433	1.2851
29	2.2311	1.2719
30	2.2269	1.2024
31	2.2064	1.1999
32	2.1928	1.1935
33	2.1692	1.1826
34	2.1505	1.1792
35	2.1390	1.1381
36	2.1275	1.1380
37	2.1184	1.1199
38	2.1109	1.1185
39	2.0865	1.1089
40	2.0843	1.1021
41	2.0646	1.0946
42	2.0422	1.0833
43	2.0208	1.0701
44	1.9814	1.0558
45	1.9728	1.0446
46	1.9582	1.0425
47	1.9547	1.0358
48	1.9543	1.0274
49	1.9530	1.0162
50	1.9450	1.0149
51	1.9316	0.9913
52	1.9302	0.9870
53	1.9123	0.9803
54	1.8710	0.9778
55	1.8592	0.9614
56	1.8570	0.9580
57	1.8460	0.9451
58	1.8177	0.9364
59	1.8078	0.9318
60	1.7817	0.9263
61	1.7652	0.9176
62	1.7198	0.9137
63	1.7184	0.9103
64	1.7130	0.8914
65	1.6933	0.8803
66	1.6895	0.8755
67	1.6882	0.8753
68	1.6873	0.8641
69	1.6870	0.8600
70	1.6712	0.8490
71	1.6566	0.8283
72	1.6527	0.8259
73	1.6368	0.8254
74	1.6250	0.8153
75	1.6238	0.8014
76	1.6005	0.7995
77	1.5837	0.7977
78	1.5656	0.7960
79	1.5306	0.7933
80	1.5273	0.7917

81	1.5227	0.7829
82	1.5166	0.7815
83	1.5084	0.7812
84	1.5025	0.7750
85	1.4926	0.7679
86	1.4885	0.7650
87	1.4829	0.7640
88	1.4738	0.7539
89	1.4499	0.7500
90	1.4246	0.7371
91	1.4231	0.7340
92	1.4181	0.7282
93	1.4166	0.7231
94	1.4057	0.7172
95	1.4049	0.7170
96	1.4017	0.7155
97	1.3886	0.7079
98	1.3707	0.7046
99	1.3682	0.7043
100	1.3615	0.7039
101	1.3601	0.7010
102	1.3533	0.6999
103	1.3489	0.6971
104	1.3331	0.6958
105	1.3204	0.6898
106	1.3122	0.6866
107	1.2997	0.6837
108	1.2968	0.6819
109	1.2943	0.6754
110	1.2883	0.6744
111	1.2819	0.6702
112	1.2791	0.6695
113	1.2771	0.6674
114	1.2692	0.6628
115	1.2691	0.6525
116	1.2550	0.6358
117	1.2357	0.6315
118	1.2327	0.6291
119	1.2202	0.6256
120	1.2200	0.6240
121	1.2195	0.6175
122	1.2110	0.6159
123	1.1983	0.6120
124	1.1937	0.6104
125	1.1913	0.6080
126	1.1719	0.6071
127	1.1653	0.6055
128	1.1651	0.6051
129	1.1636	0.6051
130	1.1542	0.6033
131	1.1235	0.5918
132	1.1117	0.5915
133	1.0942	0.5876
134	1.0894	0.5843
135	1.0891	0.5817
136	1.0888	0.5804
137	1.0758	0.5781
138	1.0744	0.5767

139	1.0685	0.5720
140	1.0678	0.5699
141	1.0671	0.5648
142	1.0521	0.5611
143	1.0483	0.5561
144	1.0446	0.5518
145	1.0287	0.5372
146	1.0161	0.5303
147	1.0069	0.5206
148	0.9700	0.5166
149	0.9679	0.4955
150	0.9675	0.4952
151	0.9548	0.4808
152	0.9390	0.4678
153	0.9357	0.4638
154	0.9217	0.4517
155	0.8818	0.4462
156	0.7315	0.4156
157	0.6755	0.3743
158	0.6201	0.3664

Duration Flows

The Facility PASSED

Flow(cfs)	Predev	Mit	Percentage	Pass/Fail
0.7876	6155	1140	18	Pass
0.8235	5143	898	17	Pass
0.8593	4322	705	16	Pass
0.8952	3644	574	15	Pass
0.9311	3105	470	15	Pass
0.9669	2699	384	14	Pass
1.0028	2398	324	13	Pass
1.0387	2084	268	12	Pass
1.0746	1852	227	12	Pass
1.1104	1633	195	11	Pass
1.1463	1455	169	11	Pass
1.1822	1281	154	12	Pass
1.2181	1154	127	11	Pass
1.2539	1027	112	10	Pass
1.2898	921	99	10	Pass
1.3257	821	88	10	Pass
1.3616	727	81	11	Pass
1.3974	659	75	11	Pass
1.4333	590	72	12	Pass
1.4692	529	64	12	Pass
1.5051	459	58	12	Pass
1.5409	412	52	12	Pass
1.5768	384	50	13	Pass
1.6127	358	45	12	Pass
1.6486	331	40	12	Pass
1.6844	301	38	12	Pass
1.7203	274	36	13	Pass
1.7562	254	32	12	Pass
1.7921	229	32	13	Pass
1.8279	218	32	14	Pass
1.8638	204	28	13	Pass
1.8997	192	25	13	Pass
1.9356	179	20	11	Pass
1.9714	161	18	11	Pass
2.0073	153	18	11	Pass
2.0432	142	13	9	Pass
2.0791	132	13	9	Pass
2.1149	125	13	10	Pass
2.1508	119	13	10	Pass
2.1867	109	13	11	Pass
2.2225	101	12	11	Pass
2.2584	93	10	10	Pass
2.2943	90	10	11	Pass
2.3302	86	8	9	Pass
2.3660	80	7	8	Pass
2.4019	75	7	9	Pass
2.4378	71	7	9	Pass
2.4737	69	6	8	Pass
2.5095	66	4	6	Pass
2.5454	64	4	6	Pass
2.5813	63	4	6	Pass
2.6172	60	4	6	Pass
2.6530	56	3	5	Pass

2.6889	53	3	5	Pass
2.7248	50	3	6	Pass
2.7607	49	3	6	Pass
2.7965	46	3	6	Pass
2.8324	46	2	4	Pass
2.8683	45	2	4	Pass
2.9042	43	2	4	Pass
2.9400	42	1	2	Pass
2.9759	38	1	2	Pass
3.0118	38	1	2	Pass
3.0477	38	1	2	Pass
3.0835	37	0	0	Pass
3.1194	37	0	0	Pass
3.1553	35	0	0	Pass
3.1912	34	0	0	Pass
3.2270	33	0	0	Pass
3.2629	33	0	0	Pass
3.2988	31	0	0	Pass
3.3347	28	0	0	Pass
3.3705	27	0	0	Pass
3.4064	26	0	0	Pass
3.4423	23	0	0	Pass
3.4781	23	0	0	Pass
3.5140	22	0	0	Pass
3.5499	22	0	0	Pass
3.5858	22	0	0	Pass
3.6216	22	0	0	Pass
3.6575	21	0	0	Pass
3.6934	21	0	0	Pass
3.7293	21	0	0	Pass
3.7651	20	0	0	Pass
3.8010	18	0	0	Pass
3.8369	17	0	0	Pass
3.8728	17	0	0	Pass
3.9086	17	0	0	Pass
3.9445	16	0	0	Pass
3.9804	16	0	0	Pass
4.0163	14	0	0	Pass
4.0521	14	0	0	Pass
4.0880	14	0	0	Pass
4.1239	14	0	0	Pass
4.1598	14	0	0	Pass
4.1956	14	0	0	Pass
4.2315	14	0	0	Pass
4.2674	14	0	0	Pass
4.3033	11	0	0	Pass
4.3391	10	0	0	Pass

Water Quality

Water Quality BMP Flow and Volume for POC #1

On-line facility volume: 0 acre-feet

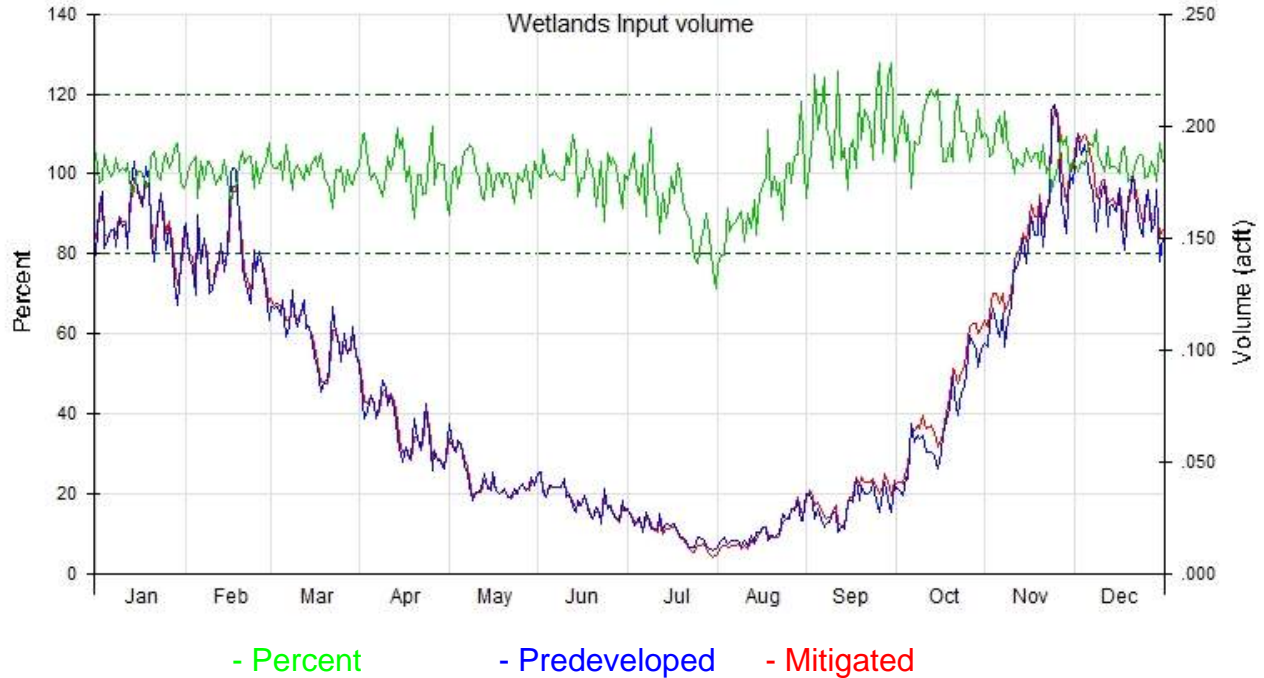
On-line facility target flow: 0 cfs.

Adjusted for 15 min: 0 cfs.

Off-line facility target flow: 0 cfs.

Adjusted for 15 min: 0 cfs.

Wetland Input Volumes



Wetlands Input Volume for POC 1

Average Annual Volume (acft)

Series 1: 501 POC 1 Predeveloped flow

Series 2: 801 POC 1 Mitigated flow

Month	Series 1	Series 2	Percent	Pass/Fail
Jan	4.8256	4.8722	101.0	Pass
Feb	4.0652	4.0614	99.9	Pass
Mar	3.3117	3.3313	100.6	Pass
Apr	1.9707	1.9974	101.4	Pass
May	1.3182	1.3044	99.0	Pass
Jun	0.9869	0.9889	100.2	Pass
Jul	0.6008	0.5661	94.2	Pass
Aug	0.5696	0.5428	95.3	Pass
Sep	0.9215	1.0232	111.0	Pass
Oct	2.0638	2.2773	110.3	Pass
Nov	4.3379	4.5353	104.5	Pass
Dec	5.1883	5.3376	102.9	Pass

Day	Predevel	Mitigated	Percent	Pass/Fail
Jan1	0.1422	0.1496	105.2	Pass
2	0.1638	0.1597	97.5	Pass
3	0.1704	0.1677	98.4	Pass
4	0.1452	0.1521	104.8	Pass
5	0.1488	0.1509	101.4	Pass
6	0.1537	0.1525	99.2	Pass
7	0.1535	0.1543	100.5	Pass
8	0.1458	0.1513	103.8	Pass
9	0.1587	0.1599	100.7	Pass
10	0.1554	0.1575	101.3	Pass
11	0.1560	0.1572	100.7	Pass
12	0.1455	0.1494	102.7	Pass
13	0.1730	0.1652	95.5	Pass
14	0.1844	0.1766	95.8	Pass

15	0.1710	0.1719	100.5	Pass
16	0.1687	0.1700	100.8	Pass
17	0.1643	0.1647	100.2	Pass
18	0.1821	0.1753	96.3	Pass
19	0.1757	0.1724	98.1	Pass
20	0.1530	0.1588	103.8	Pass
21	0.1392	0.1472	105.8	Pass
22	0.1597	0.1588	99.4	Pass
23	0.1703	0.1678	98.5	Pass
24	0.1621	0.1654	102.0	Pass
25	0.1446	0.1523	105.3	Pass
26	0.1552	0.1572	101.2	Pass
27	0.1430	0.1477	103.3	Pass
28	0.1307	0.1391	106.4	Pass
29	0.1198	0.1289	107.6	Pass
30	0.1390	0.1364	98.1	Pass
31	0.1546	0.1494	96.6	Pass
Feb1	0.1563	0.1530	97.9	Pass
2	0.1407	0.1433	101.8	Pass
3	0.1373	0.1416	103.1	Pass
4	0.1248	0.1303	104.4	Pass
5	0.1606	0.1507	93.8	Pass
6	0.1385	0.1430	103.3	Pass
7	0.1500	0.1478	98.5	Pass
8	0.1388	0.1432	103.2	Pass
9	0.1253	0.1290	102.9	Pass
10	0.1265	0.1279	101.2	Pass
11	0.1373	0.1336	97.3	Pass
12	0.1407	0.1401	99.5	Pass
13	0.1475	0.1455	98.6	Pass
14	0.1350	0.1397	103.5	Pass
15	0.1444	0.1420	98.4	Pass
16	0.1786	0.1649	92.3	Pass
17	0.1815	0.1730	95.3	Pass
18	0.1802	0.1732	96.1	Pass
19	0.1584	0.1619	102.2	Pass
20	0.1371	0.1451	105.8	Pass
21	0.1322	0.1359	102.8	Pass
22	0.1265	0.1314	103.9	Pass
23	0.1206	0.1259	104.4	Pass
24	0.1444	0.1393	96.5	Pass
25	0.1348	0.1390	103.1	Pass
26	0.1438	0.1405	97.7	Pass
27	0.1373	0.1388	101.1	Pass
28	0.1268	0.1302	102.7	Pass
29	0.1132	0.1217	107.5	Pass
Mar1	0.1195	0.1230	102.9	Pass
2	0.1183	0.1198	101.3	Pass
3	0.1196	0.1211	101.3	Pass
4	0.1152	0.1189	103.2	Pass
5	0.1225	0.1208	98.6	Pass
6	0.1058	0.1137	107.4	Pass
7	0.1106	0.1125	101.7	Pass
8	0.1268	0.1216	95.9	Pass
9	0.1158	0.1171	101.1	Pass
10	0.1102	0.1129	102.5	Pass
11	0.1163	0.1165	100.1	Pass
12	0.1225	0.1209	98.7	Pass

13	0.1095	0.1121	102.4	Pass
14	0.1100	0.1097	99.7	Pass
15	0.1026	0.1057	103.0	Pass
16	0.0941	0.0983	104.5	Pass
17	0.0931	0.0948	101.8	Pass
18	0.0814	0.0856	105.2	Pass
19	0.0857	0.0851	99.3	Pass
20	0.0865	0.0847	97.9	Pass
21	0.0932	0.0903	96.8	Pass
22	0.1191	0.1090	91.5	Pass
23	0.1075	0.1086	101.0	Pass
24	0.1024	0.1031	100.7	Pass
25	0.0948	0.0965	101.8	Pass
26	0.1072	0.1023	95.4	Pass
27	0.0983	0.0992	101.0	Pass
28	0.1024	0.1002	97.9	Pass
29	0.1100	0.1070	97.2	Pass
30	0.0976	0.0982	100.6	Pass
31	0.0932	0.0950	101.9	Pass
Apr1	0.0769	0.0841	109.4	Pass
2	0.0694	0.0764	110.2	Pass
3	0.0732	0.0757	103.5	Pass
4	0.0800	0.0787	98.4	Pass
5	0.0758	0.0761	100.4	Pass
6	0.0697	0.0692	99.3	Pass
7	0.0748	0.0725	96.9	Pass
8	0.0864	0.0814	94.2	Pass
9	0.0830	0.0829	99.9	Pass
10	0.0750	0.0783	104.4	Pass
11	0.0800	0.0808	100.9	Pass
12	0.0735	0.0775	105.4	Pass
13	0.0613	0.0682	111.3	Pass
14	0.0565	0.0601	106.4	Pass
15	0.0498	0.0542	108.8	Pass
16	0.0569	0.0560	98.3	Pass
17	0.0511	0.0520	101.7	Pass
18	0.0519	0.0506	97.5	Pass
19	0.0690	0.0613	88.8	Pass
20	0.0603	0.0601	99.7	Pass
21	0.0557	0.0555	99.6	Pass
22	0.0616	0.0583	94.6	Pass
23	0.0759	0.0721	95.0	Pass
24	0.0622	0.0653	105.1	Pass
25	0.0459	0.0514	111.8	Pass
26	0.0552	0.0537	97.2	Pass
27	0.0503	0.0517	102.8	Pass
28	0.0495	0.0506	102.1	Pass
29	0.0466	0.0477	102.4	Pass
30	0.0530	0.0504	95.0	Pass
May1	0.0667	0.0600	89.9	Pass
2	0.0575	0.0577	100.3	Pass
3	0.0543	0.0554	102.1	Pass
4	0.0595	0.0575	96.6	Pass
5	0.0577	0.0581	100.6	Pass
6	0.0485	0.0514	105.8	Pass
7	0.0449	0.0475	105.8	Pass
8	0.0393	0.0422	107.3	Pass
9	0.0324	0.0345	106.3	Pass

10	0.0363	0.0365	100.7	Pass
11	0.0365	0.0362	99.4	Pass
12	0.0382	0.0363	95.0	Pass
13	0.0443	0.0414	93.5	Pass
14	0.0382	0.0391	102.6	Pass
15	0.0374	0.0371	99.2	Pass
16	0.0454	0.0427	94.2	Pass
17	0.0374	0.0374	99.9	Pass
18	0.0355	0.0356	100.2	Pass
19	0.0375	0.0363	96.9	Pass
20	0.0379	0.0379	100.0	Pass
21	0.0344	0.0345	100.2	Pass
22	0.0343	0.0333	97.2	Pass
23	0.0382	0.0355	92.8	Pass
24	0.0359	0.0360	100.1	Pass
25	0.0387	0.0384	99.1	Pass
26	0.0399	0.0391	98.1	Pass
27	0.0372	0.0380	102.3	Pass
28	0.0387	0.0375	97.1	Pass
29	0.0434	0.0407	93.8	Pass
30	0.0392	0.0404	103.1	Pass
31	0.0445	0.0446	100.3	Pass
Jun1	0.0451	0.0446	99.0	Pass
2	0.0365	0.0387	105.9	Pass
3	0.0339	0.0344	101.3	Pass
4	0.0392	0.0390	99.5	Pass
5	0.0388	0.0387	100.0	Pass
6	0.0387	0.0390	100.8	Pass
7	0.0386	0.0383	99.2	Pass
8	0.0391	0.0385	98.6	Pass
9	0.0421	0.0414	98.4	Pass
10	0.0343	0.0362	105.4	Pass
11	0.0350	0.0358	102.4	Pass
12	0.0301	0.0331	109.8	Pass
13	0.0279	0.0294	105.3	Pass
14	0.0324	0.0305	94.3	Pass
15	0.0308	0.0305	98.9	Pass
16	0.0346	0.0342	98.8	Pass
17	0.0295	0.0313	106.1	Pass
18	0.0270	0.0278	102.8	Pass
19	0.0247	0.0251	101.5	Pass
20	0.0300	0.0276	91.9	Pass
21	0.0276	0.0273	99.1	Pass
22	0.0225	0.0232	103.1	Pass
23	0.0381	0.0335	88.0	Pass
24	0.0288	0.0303	105.2	Pass
25	0.0297	0.0304	102.4	Pass
26	0.0265	0.0276	104.1	Pass
27	0.0246	0.0250	101.8	Pass
28	0.0239	0.0230	96.6	Pass
29	0.0325	0.0297	91.5	Pass
30	0.0280	0.0280	99.8	Pass
Jul1	0.0289	0.0285	98.7	Pass
2	0.0263	0.0269	102.4	Pass
3	0.0216	0.0227	105.0	Pass
4	0.0228	0.0223	97.7	Pass
5	0.0254	0.0241	94.7	Pass
6	0.0188	0.0192	102.3	Pass

7	0.0272	0.0243	89.3	Pass
8	0.0261	0.0260	99.9	Pass
9	0.0200	0.0223	111.7	Pass
10	0.0200	0.0193	96.3	Pass
11	0.0201	0.0189	93.8	Pass
12	0.0268	0.0228	85.1	Pass
13	0.0189	0.0180	95.3	Pass
14	0.0224	0.0198	88.8	Pass
15	0.0214	0.0200	93.3	Pass
16	0.0212	0.0211	99.3	Pass
17	0.0220	0.0210	95.3	Pass
18	0.0184	0.0189	102.5	Pass
19	0.0162	0.0159	98.2	Pass
20	0.0164	0.0153	93.2	Pass
21	0.0152	0.0137	90.2	Pass
22	0.0122	0.0108	88.9	Pass
23	0.0121	0.0100	82.1	Pass
24	0.0122	0.0096	78.7	Fail
25	0.0160	0.0124	77.6	Fail
26	0.0153	0.0128	83.5	Pass
27	0.0151	0.0131	86.7	Pass
28	0.0129	0.0116	90.3	Pass
29	0.0108	0.0091	84.9	Pass
30	0.0101	0.0076	76.0	Fail
31	0.0111	0.0079	71.4	Fail
Aug1	0.0119	0.0092	77.2	Fail
2	0.0147	0.0118	79.8	Fail
3	0.0161	0.0129	79.9	Fail
4	0.0132	0.0121	91.3	Pass
5	0.0142	0.0121	85.6	Pass
6	0.0145	0.0127	87.4	Pass
7	0.0147	0.0129	88.0	Pass
8	0.0144	0.0130	89.9	Pass
9	0.0119	0.0108	90.7	Pass
10	0.0149	0.0123	83.1	Pass
11	0.0123	0.0111	90.3	Pass
12	0.0170	0.0147	86.5	Pass
13	0.0139	0.0130	93.4	Pass
14	0.0187	0.0158	84.5	Pass
15	0.0187	0.0177	94.8	Pass
16	0.0206	0.0201	97.3	Pass
17	0.0209	0.0207	98.8	Pass
18	0.0151	0.0168	111.3	Pass
19	0.0171	0.0161	94.2	Pass
20	0.0164	0.0162	99.3	Pass
21	0.0176	0.0167	94.8	Pass
22	0.0177	0.0173	97.8	Pass
23	0.0264	0.0233	88.4	Pass
24	0.0242	0.0247	102.4	Pass
25	0.0243	0.0250	102.8	Pass
26	0.0292	0.0286	97.7	Pass
27	0.0279	0.0292	104.6	Pass
28	0.0324	0.0340	104.9	Pass
29	0.0240	0.0284	118.2	Pass
30	0.0239	0.0260	108.8	Pass
31	0.0353	0.0331	93.8	Pass
Sep1	0.0360	0.0368	102.4	Pass
2	0.0318	0.0351	110.1	Pass

3	0.0244	0.0305	124.8	Fail
4	0.0289	0.0321	111.0	Pass
5	0.0248	0.0288	116.2	Pass
6	0.0208	0.0258	123.9	Fail
7	0.0222	0.0248	111.4	Pass
8	0.0233	0.0254	109.2	Pass
9	0.0273	0.0277	101.6	Pass
10	0.0265	0.0303	114.3	Pass
11	0.0184	0.0231	125.7	Fail
12	0.0210	0.0217	103.6	Pass
13	0.0201	0.0214	106.3	Pass
14	0.0323	0.0310	96.0	Pass
15	0.0325	0.0345	105.9	Pass
16	0.0317	0.0344	108.5	Pass
17	0.0422	0.0429	101.6	Pass
18	0.0330	0.0396	120.0	Fail
19	0.0395	0.0429	108.4	Pass
20	0.0354	0.0411	116.0	Pass
21	0.0360	0.0412	114.3	Pass
22	0.0373	0.0412	110.3	Pass
23	0.0410	0.0424	103.4	Pass
24	0.0326	0.0391	119.7	Pass
25	0.0278	0.0354	127.6	Fail
26	0.0372	0.0392	105.3	Pass
27	0.0408	0.0450	110.3	Pass
28	0.0334	0.0413	123.9	Fail
29	0.0276	0.0353	127.6	Fail
30	0.0402	0.0415	103.2	Pass
Oct1	0.0382	0.0405	106.2	Pass
2	0.0371	0.0412	111.1	Pass
3	0.0346	0.0400	115.6	Pass
4	0.0430	0.0465	108.0	Pass
5	0.0424	0.0476	112.1	Pass
6	0.0672	0.0649	96.6	Pass
7	0.0592	0.0640	108.0	Pass
8	0.0617	0.0662	107.3	Pass
9	0.0602	0.0648	107.6	Pass
10	0.0616	0.0708	114.8	Pass
11	0.0547	0.0647	118.3	Pass
12	0.0541	0.0652	120.6	Fail
13	0.0546	0.0661	121.1	Fail
14	0.0527	0.0630	119.6	Pass
15	0.0466	0.0565	121.1	Fail
16	0.0542	0.0599	110.5	Pass
17	0.0615	0.0634	103.2	Pass
18	0.0689	0.0712	103.3	Pass
19	0.0734	0.0791	107.7	Pass
20	0.0886	0.0913	103.1	Pass
21	0.0796	0.0912	114.6	Pass
22	0.0711	0.0847	119.2	Pass
23	0.0815	0.0903	110.8	Pass
24	0.0837	0.0926	110.6	Pass
25	0.0896	0.0986	110.1	Pass
26	0.1069	0.1102	103.1	Pass
27	0.1037	0.1117	107.8	Pass
28	0.1005	0.1121	111.5	Pass
29	0.0924	0.1073	116.2	Pass
30	0.1006	0.1098	109.2	Pass

31	0.1028	0.1134	110.4	Pass
Nov1	0.1012	0.1102	108.9	Pass
2	0.1121	0.1169	104.4	Pass
3	0.1188	0.1250	105.2	Pass
4	0.1115	0.1251	112.3	Pass
5	0.1057	0.1211	114.6	Pass
6	0.1161	0.1250	107.7	Pass
7	0.1015	0.1173	115.5	Pass
8	0.1133	0.1200	106.0	Pass
9	0.1200	0.1261	105.1	Pass
10	0.1391	0.1392	100.1	Pass
11	0.1366	0.1423	104.2	Pass
12	0.1407	0.1447	102.8	Pass
13	0.1495	0.1524	102.0	Pass
14	0.1390	0.1482	106.6	Pass
15	0.1463	0.1537	105.0	Pass
16	0.1596	0.1645	103.1	Pass
17	0.1515	0.1596	105.3	Pass
18	0.1517	0.1593	105.0	Pass
19	0.1669	0.1696	101.6	Pass
20	0.1459	0.1563	107.1	Pass
21	0.1634	0.1635	100.1	Pass
22	0.1657	0.1688	101.9	Pass
23	0.2071	0.1978	95.5	Pass
24	0.2094	0.2070	98.9	Pass
25	0.2019	0.2058	101.9	Pass
26	0.1663	0.1824	109.7	Pass
27	0.1632	0.1749	107.1	Pass
28	0.1523	0.1665	109.3	Pass
29	0.1784	0.1785	100.1	Pass
30	0.1747	0.1810	103.6	Pass
Dec1	0.1826	0.1876	102.8	Pass
2	0.1961	0.1971	100.5	Pass
3	0.1873	0.1933	103.2	Pass
4	0.1917	0.1963	102.4	Pass
5	0.1870	0.1950	104.3	Pass
6	0.1754	0.1886	107.6	Pass
7	0.1709	0.1828	107.0	Pass
8	0.1527	0.1695	111.0	Pass
9	0.1601	0.1677	104.8	Pass
10	0.1708	0.1751	102.6	Pass
11	0.1748	0.1756	100.5	Pass
12	0.1552	0.1658	106.8	Pass
13	0.1638	0.1661	101.4	Pass
14	0.1648	0.1676	101.7	Pass
15	0.1617	0.1639	101.4	Pass
16	0.1725	0.1725	100.0	Pass
17	0.1565	0.1654	105.7	Pass
18	0.1445	0.1542	106.7	Pass
19	0.1674	0.1640	97.9	Pass
20	0.1731	0.1715	99.1	Pass
21	0.1792	0.1791	99.9	Pass
22	0.1639	0.1698	103.6	Pass
23	0.1554	0.1631	105.0	Pass
24	0.1508	0.1575	104.4	Pass
25	0.1625	0.1608	99.0	Pass
26	0.1718	0.1707	99.4	Pass
27	0.1532	0.1580	103.1	Pass

28	0.1569	0.1582	100.8	Pass
29	0.1718	0.1687	98.2	Pass
30	0.1396	0.1505	107.8	Pass
31	0.1507	0.1544	102.5	Pass

LID Report

LID Technique	Used for Treatment ?	Total Volume Needs Treatment (ac-ft)	Volume Through Facility (ac-ft)	Infiltration Volume (ac-ft)	Cumulative Volume Infiltration Credit	Percent Volume Infiltrated	Water Quality	Percent Water Quality Treated	Comment
Vault 1 POC	<input type="checkbox"/>	1584.19			<input type="checkbox"/>	0.00			
Trapezoidal Pond 1 POC	<input type="checkbox"/>	1249.59			<input type="checkbox"/>	0.00			
Total Volume Infiltrated		2833.78	0.00	0.00		0.00	0.00	0%	No Treat Credit
Compliance with LID Standard 8% of 2-yr to 50% of 2-yr									Duration Analysis Result = Failed

Model Default Modifications

Total of 0 changes have been made.

PERLND Changes

No PERLND changes have been made.

IMPLND Changes

No IMPLND changes have been made.

Appendix
Predeveloped Schematic



Mitigated Schematic



Predeveloped UCI File

RUN

GLOBAL

```
WVHM4 model simulation
START      1901 10 01      END      2059 09 30
RUN INTERP OUTPUT LEVEL   3      0
RESUME     0 RUN          1
UNIT SYSTEM 1
```

END GLOBAL

FILES

```
<File> <Un#> <-----File Name----->***
<-ID->                                     ***
WDM      26      Hydroperiod.wdm
MESSU    25      PreHydroperiod.MES
          27      PreHydroperiod.L61
          28      PreHydroperiod.L62
          30      POCHydroperiod1.dat
```

END FILES

OPN SEQUENCE

```
INGRP          INDELT 00:15
  PERLND        16
  IMPLND        11
  IMPLND         1
  RCHRES         1
  COPY          501
  DISPLY         1
```

END INGRP

END OPN SEQUENCE

DISPLY

DISPLY-INFO1

```
# - #<-----Title----->***TRAN PIVL DIG1 FIL1  PYR DIG2 FIL2 YRND
1      On-site Pre          MAX          1      2      30      9
```

END DISPLY-INFO1

END DISPLY

COPY

TIMESERIES

```
# - # NPT NMN ***
1      1      1
501    1      1
```

END TIMESERIES

END COPY

GENER

OPCODE

```
#      # OPCODE ***
```

END OPCODE

PARAM

```
#      #          K ***
```

END PARAM

END GENER

PERLND

GEN-INFO

```
<PLS ><-----Name----->NBLKS  Unit-systems  Printer ***
# - #          User  t-series  Engl Metr ***
          in  out          ***
16      C, Lawn, Flat          1      1      1      1      27      0
```

END GEN-INFO

*** Section PWATER***

ACTIVITY

```
<PLS > ***** Active Sections *****
# - # ATMP SNOW PWAT  SED  PST  PWG  PQAL MSTL  PEST  NITR  PHOS  TRAC ***
16      0      0      1      0      0      0      0      0      0      0      0
```

END ACTIVITY

PRINT-INFO

```
<PLS > ***** Print-flags ***** PIVL  PYR
# - # ATMP SNOW PWAT  SED  PST  PWG  PQAL MSTL  PEST  NITR  PHOS  TRAC  *****
```

16 0 0 4 0 0 0 0 0 0 0 0 0 0 1 9
END PRINT-INFO

PWAT-PARM1
<PLS > PWATER variable monthly parameter value flags ***
- # CSNO RTOP UZFG VCS VUZ VNN VIFW VIRC VLE INFC HWT ***
16 0 0 0 0 0 0 0 0 0 0 0
END PWAT-PARM1

PWAT-PARM2
<PLS > PWATER input info: Part 2 ***
- # ***FOREST LZSN INFILT LSUR SLSUR KVARY AGWRC
16 0 4.5 0.03 400 0.05 0.5 0.996
END PWAT-PARM2

PWAT-PARM3
<PLS > PWATER input info: Part 3 ***
- # ***PETMAX PETMIN INFEXP INFILD DEEPFR BASETP AGWETP
16 0 0 2 2 0 0 0
END PWAT-PARM3

PWAT-PARM4
<PLS > PWATER input info: Part 4 ***
- # CEPSC UZSN NSUR INTFW IRC LZETP ***
16 0.1 0.25 0.25 6 0.5 0.25
END PWAT-PARM4

PWAT-STATE1
<PLS > *** Initial conditions at start of simulation
ran from 1990 to end of 1992 (pat 1-11-95) RUN 21 ***
- # *** CEPS SURS UZS IFWS LZS AGWS GWVS
16 0 0 0 0 2.5 1 0
END PWAT-STATE1

END PERLND

IMPLND

GEN-INFO
<PLS ><-----Name-----> Unit-systems Printer ***
- # User t-series Engl Metr ***
in out ***
11 PARKING/FLAT 1 1 1 27 0
1 ROADS/FLAT 1 1 1 27 0
END GEN-INFO
*** Section IWATER***

ACTIVITY
<PLS > ***** Active Sections *****
- # ATMP SNOW IWAT SLD IWG IQAL ***
11 0 0 1 0 0 0
1 0 0 1 0 0 0
END ACTIVITY

PRINT-INFO
<ILS > ***** Print-flags ***** PIVL PYR
- # ATMP SNOW IWAT SLD IWG IQAL *****
11 0 0 4 0 0 0 1 9
1 0 0 4 0 0 0 1 9
END PRINT-INFO

IWAT-PARM1
<PLS > IWATER variable monthly parameter value flags ***
- # CSNO RTOP VRS VNN RTLI ***
11 0 0 0 0 0
1 0 0 0 0 0
END IWAT-PARM1

IWAT-PARM2
<PLS > IWATER input info: Part 2 ***
- # *** LSUR SLSUR NSUR RETSC
11 400 0.01 0.1 0.1

1 400 0.01 0.1 0.1
END IWAT-PARM2

IWAT-PARM3
<PLS > IWATER input info: Part 3 ***
- # ***PETMAX PETMIN
11 0 0
1 0 0
END IWAT-PARM3

IWAT-STATE1
<PLS > *** Initial conditions at start of simulation
- # *** RETS SURS
11 0 0
1 0 0
END IWAT-STATE1

END IMPLND

SCHEMATIC
<-Source-> <--Area--> <-Target-> MBLK ***
<Name> # <-factor-> <Name> # Tbl# ***
Off-Site Property***
PERLND 16 0.62 RCHRES 1 2
PERLND 16 0.62 RCHRES 1 3
IMPLND 11 3.15 RCHRES 1 5
On-site Pre***
PERLND 16 3.119 COPY 501 12
PERLND 16 3.119 COPY 501 13
PERLND 16 3.119 COPY 501 14
IMPLND 11 1.97 COPY 501 15
Off-Site Flow***
PERLND 16 4.28 COPY 501 12
PERLND 16 4.28 COPY 501 13
PERLND 16 4.28 COPY 501 14
IMPLND 1 1.5 COPY 501 15

*****Routing*****
RCHRES 1 1 COPY 501 16
END SCHEMATIC

NETWORK
<-Volume-> <-Grp> <-Member-><--Mult-->Tran <-Target vols> <-Grp> <-Member-> ***
<Name> # <Name> # #<-factor->strg <Name> # # <Name> # # ***
COPY 501 OUTPUT MEAN 1 1 48.4 DISPLY 1 INPUT TIMSER 1

<-Volume-> <-Grp> <-Member-><--Mult-->Tran <-Target vols> <-Grp> <-Member-> ***
<Name> # <Name> # #<-factor->strg <Name> # # <Name> # # ***
END NETWORK

RCHRES
GEN-INFO
RCHRES Name Nexits Unit Systems Printer ***
- #<-----><----> User T-series Engr Metr LKFG ***
in out ***
1 Trapezoidal Pond-031 1 1 1 1 28 0 1
END GEN-INFO
*** Section RCHRES***

ACTIVITY
<PLS > ***** Active Sections *****
- # HYFG ADFG CNFG HTFG SDFG GQFG OXFG NUGF PKFG PHFG ***
1 1 0 0 0 0 0 0 0 0
END ACTIVITY

PRINT-INFO
<PLS > ***** Print-flags ***** PIVL PYR
- # HYDR ADCA CONS HEAT SED GQL OXRX NUTR PLNK PHCB PIVL PYR *****

3.166667	0.163722	0.400132	0.063864
3.250000	0.165840	0.413863	0.064699
3.333333	0.167969	0.427772	0.065523
3.416667	0.170110	0.441859	0.066337
3.500000	0.172262	0.456124	0.067141
3.583333	0.174426	0.470570	0.067936
3.666667	0.176601	0.485196	0.086016
3.750000	0.178788	0.500004	0.102647
3.833333	0.180986	0.514994	0.113838
3.916667	0.183196	0.530168	0.122971
4.000000	0.185417	0.545527	0.130921
4.083333	0.187649	0.561072	0.138078
4.166667	0.189893	0.576803	0.144654
4.250000	0.192149	0.592721	0.160608
4.333333	0.194416	0.608828	0.170824
4.416667	0.196694	0.625124	0.179649
4.500000	0.198984	0.641611	0.187676
4.583333	0.201286	0.658289	0.195140
4.666667	0.203598	0.675159	0.202171
4.750000	0.205923	0.692222	0.208851
4.833333	0.208259	0.709480	0.215236
4.916667	0.210606	0.726932	0.221369
5.000000	0.212965	0.744581	0.227280
5.083333	0.215335	0.762427	0.232995
5.166667	0.217717	0.780471	0.238535
5.250000	0.220110	0.798714	0.243916
5.333333	0.222515	0.817156	0.249154
5.416667	0.224931	0.835800	0.254259
5.500000	0.227359	0.854645	0.259243
5.583333	0.229798	0.873694	0.264114
5.666667	0.232249	0.892946	0.268881
5.750000	0.234711	0.912402	0.273549
5.833333	0.237184	0.932064	0.278127
5.916667	0.239669	0.951933	0.282619
6.000000	0.242166	0.972010	0.287029
6.083333	0.244674	0.992295	0.291364
6.166667	0.247194	1.012789	0.295626
6.250000	0.249725	1.033494	0.299820
6.333333	0.252267	1.054411	0.303948
6.416667	0.254821	1.075539	0.308015
6.500000	0.257386	1.096881	0.312023
6.583333	0.259963	1.118437	0.698266
6.666667	0.262552	1.140209	1.394140
6.750000	0.265152	1.162197	2.262147
6.833333	0.267763	1.184401	3.210032
6.916667	0.270386	1.206824	4.143880
7.000000	0.273020	1.229466	4.974055
7.083333	0.275666	1.252328	5.632565
7.166667	0.278323	1.275411	6.096732
7.250000	0.280992	1.298716	6.417490
7.333333	0.283672	1.322243	6.818561
7.416667	0.286364	1.345995	7.137813
7.500000	0.289067	1.369971	7.442974

END FTABLE 1

END FTABLES

EXT SOURCES

<-Volume->	<Member>	SsysSgap<--Mult-->	Tran	<-Target vols>	<-Grp>	<-Member->	***	
<Name>	#	<Name>	#	tem strg<-factor->	strg	<Name>	# #	***
WDM	2	PREC	ENGL	1	PERLND	1 999 EXTNL	PREC	
WDM	2	PREC	ENGL	1	IMPLND	1 999 EXTNL	PREC	
WDM	1	EVAP	ENGL	1	PERLND	1 999 EXTNL	PETINP	
WDM	1	EVAP	ENGL	1	IMPLND	1 999 EXTNL	PETINP	

END EXT SOURCES

EXT TARGETS

<-Volume->	<-Grp>	<-Member->	<--Mult-->	Tran	<-Volume->	<Member>	Tsys	Tgap	Amd	***
<Name>	#	<Name>	#	#<-factor->	strg	<Name>	#	<Name>	tem strg	strg***
COPY	501	OUTPUT	MEAN	1 1	48.4	WDM	501	FLOW	ENGL	REPL

```

RCHRES 1 HYDR RO 1 1 1 WDM 1002 FLOW ENGL REPL
RCHRES 1 HYDR STAGE 1 1 1 WDM 1003 STAG ENGL REPL
END EXT TARGETS

```

MASS-LINK

```

<Volume> <-Grp> <-Member-><--Mult--> <Target> <-Grp> <-Member->***
<Name> <Name> # #<-factor-> <Name> <Name> # #***
MASS-LINK 2
PERLND PWATER SURO 0.083333 RCHRES INFLOW IVOL
END MASS-LINK 2

MASS-LINK 3
PERLND PWATER IFWO 0.083333 RCHRES INFLOW IVOL
END MASS-LINK 3

MASS-LINK 5
IMPLND IWATER SURO 0.083333 RCHRES INFLOW IVOL
END MASS-LINK 5

MASS-LINK 12
PERLND PWATER SURO 0.083333 COPY INPUT MEAN
END MASS-LINK 12

MASS-LINK 13
PERLND PWATER IFWO 0.083333 COPY INPUT MEAN
END MASS-LINK 13

MASS-LINK 14
PERLND PWATER AGWO 0.083333 COPY INPUT MEAN
END MASS-LINK 14

MASS-LINK 15
IMPLND IWATER SURO 0.083333 COPY INPUT MEAN
END MASS-LINK 15

MASS-LINK 16
RCHRES ROFLOW COPY INPUT MEAN
END MASS-LINK 16

```

END MASS-LINK

END RUN

Mitigated UCI File

RUN

GLOBAL

WVHM4 model simulation
START 1901 10 01 END 2059 09 30
RUN INTERP OUTPUT LEVEL 3 0
RESUME 0 RUN 1 UNIT SYSTEM 1
END GLOBAL

FILES

<File>	<Un#>	<-----File Name----->	***
<-ID->			***
WDM	26	Hydroperiod.wdm	
MESSU	25	MitHydroperiod.MES	
	27	MitHydroperiod.L61	
	28	MitHydroperiod.L62	
	30	POCHydroperiod1.dat	

END FILES

OPN SEQUENCE

INGRP INDELT 00:15
PERLND 13
IMPLND 1
IMPLND 4
IMPLND 14
PERLND 16
IMPLND 11
RCHRES 1
RCHRES 2
COPY 1
COPY 501
COPY 601
DISPLY 1

END INGRP

END OPN SEQUENCE

DISPLY

DISPLY-INF01

#	-	#	<-----Title----->	***	TRAN	PIVL	DIG1	FIL1	PYR	DIG2	FIL2	YRND
1			Vault 1		MAX				1	2	30	9

END DISPLY-INF01

END DISPLY

COPY

TIMESERIES

#	-	#	NPT	NMN	***
1			1	1	
501			1	1	
601			1	1	

END TIMESERIES

END COPY

GENER

OPCODE

#	#	OPCD	***
---	---	------	-----

END OPCODE

PARM

#	#	K	***
---	---	---	-----

END PARM

END GENER

PERLND

GEN-INFO

<PLS >	<-----Name----->	NBLKS	Unit-systems		Printer		***
#	-	#	User	t-series	Engl	Metr	***
			in	out			***
13	C, Pasture, Flat	1	1	1	1	27	0
16	C, Lawn, Flat	1	1	1	1	27	0

END GEN-INFO

*** Section PWATER***

ACTIVITY

```

<PLS > ***** Active Sections *****
# - # ATMP SNOW PWAT SED PST PWG PQAL MSTL PEST NITR PHOS TRAC ***
13      0      0      1      0      0      0      0      0      0      0      0      0
16      0      0      1      0      0      0      0      0      0      0      0      0
END ACTIVITY

```

```

PRINT-INFO
<PLS > ***** Print-flags ***** PIVL PYR
# - # ATMP SNOW PWAT SED PST PWG PQAL MSTL PEST NITR PHOS TRAC *****
13      0      0      4      0      0      0      0      0      0      0      0      0      1      9
16      0      0      4      0      0      0      0      0      0      0      0      0      1      9
END PRINT-INFO

```

```

PWAT-PARM1
<PLS > PWATER variable monthly parameter value flags ***
# - # CSNO RTOP UZFG VCS VUZ VNN VIFW VIRC VLE INFC HWT ***
13      0      0      0      0      0      0      0      0      0      0      0
16      0      0      0      0      0      0      0      0      0      0      0
END PWAT-PARM1

```

```

PWAT-PARM2
<PLS > PWATER input info: Part 2 ***
# - # ***FOREST LZSN INFILT LRSUR SLSUR KVARV AGWRC
13      0      4.5      0.06      400      0.05      0.5      0.996
16      0      4.5      0.03      400      0.05      0.5      0.996
END PWAT-PARM2

```

```

PWAT-PARM3
<PLS > PWATER input info: Part 3 ***
# - # ***PETMAX PETMIN INFEXP INFILD DEEPFR BASETP AGWETP
13      0      0      2      2      0      0      0
16      0      0      2      2      0      0      0
END PWAT-PARM3

```

```

PWAT-PARM4
<PLS > PWATER input info: Part 4 ***
# - # CEPSC UZSN NSUR INTFW IRC LZETP ***
13      0.15      0.4      0.3      6      0.5      0.4
16      0.1      0.25      0.25      6      0.5      0.25
END PWAT-PARM4

```

```

PWAT-STATE1
<PLS > *** Initial conditions at start of simulation
ran from 1990 to end of 1992 (pat 1-11-95) RUN 21 ***
# - # *** CEPS SURS UZS IFWS LZS AGWS GWVS
13      0      0      0      0      2.5      1      0
16      0      0      0      0      2.5      1      0
END PWAT-STATE1

```

END PERLND

IMPLND

```

GEN-INFO
<PLS ><-----Name-----> Unit-systems Printer ***
# - # User t-series Engl Metr ***
in out ***
1 ROADS/FLAT 1 1 1 27 0
4 ROOF TOPS/FLAT 1 1 1 27 0
14 POND 1 1 1 27 0
11 PARKING/FLAT 1 1 1 27 0
END GEN-INFO
*** Section IWATER***

```

```

ACTIVITY
<PLS > ***** Active Sections *****
# - # ATMP SNOW IWAT SLD IWG IQAL ***
1      0      0      1      0      0      0
4      0      0      1      0      0      0
14     0      0      1      0      0      0
11     0      0      1      0      0      0
END ACTIVITY

```

```

PRINT-INFO
<ILS > ***** Print-flags ***** PIVL  PYR
# - # ATMP SNOW IWAT  SLD  IWG IQAL  *****
1   0   0   4   0   0   4   1   9
4   0   0   4   0   0   0   1   9
14  0   0   4   0   0   0   1   9
11  0   0   4   0   0   0   1   9
END PRINT-INFO

```

```

IWAT-PARM1
<PLS > IWATER variable monthly parameter value flags ***
# - # CSNO RTOP  VRS  VNN RTLI  ***
1   0   0   0   0   0
4   0   0   0   0   0
14  0   0   0   0   0
11  0   0   0   0   0
END IWAT-PARM1

```

```

IWAT-PARM2
<PLS > IWATER input info: Part 2      ***
# - # ***  LSUR    SLSUR    NSUR    RETSC
1   400    0.01    0.1    0.1
4   400    0.01    0.1    0.1
14  400    0.01    0.1    0.1
11  400    0.01    0.1    0.1
END IWAT-PARM2

```

```

IWAT-PARM3
<PLS > IWATER input info: Part 3      ***
# - # ***PETMAX  PETMIN
1   0        0
4   0        0
14  0        0
11  0        0
END IWAT-PARM3

```

```

IWAT-STATE1
<PLS > *** Initial conditions at start of simulation
# - # ***  RETS    SURS
1   0        0
4   0        0
14  0        0
11  0        0
END IWAT-STATE1

```

END IMPLND

```

SCHEMATIC
<-Source->          <--Area-->          <-Target->          MBLK    ***
<Name> #           <-factor->          <Name> #           Tbl#    ***
On-site Post***
PERLND 13          1.022          RCHRES 1           2
PERLND 13          1.022          RCHRES 1           3
IMPLND 1           2.506          RCHRES 1           5
IMPLND 4           0.987          RCHRES 1           5
IMPLND 14          0.574          RCHRES 1           5
Off-Site Property***
PERLND 16          0.62           RCHRES 2           2
PERLND 16          0.62           RCHRES 2           3
IMPLND 11          3.15           RCHRES 2           5
Off-site Flow***
PERLND 16          4.28           COPY 501           12
PERLND 16          4.28           COPY 601           12
PERLND 16          4.28           COPY 501           13
PERLND 16          4.28           COPY 601           13
PERLND 16          4.28           COPY 501           14
PERLND 16          4.28           COPY 601           14
IMPLND 1           1.5            COPY 501           15
IMPLND 1           1.5            COPY 601           15

```

*****Routing*****

```

PERLND 13          1.022      COPY      1      12
IMPLND  1          2.506      COPY      1      15
IMPLND  4          0.987      COPY      1      15
IMPLND 14          0.574      COPY      1      15
PERLND 13          1.022      COPY      1      13
PERLND 16          0.62       COPY      1      12
IMPLND 11          3.15       COPY      1      15
PERLND 16          0.62       COPY      1      13
RCHRES  1           1         COPY     501    16
RCHRES  2           1         COPY     501    16
END SCHEMATIC

```

NETWORK

```

<-Volume-> <-Grp> <-Member-><--Mult-->Tran <-Target vols> <-Grp> <-Member-> ***
<Name> # <Name> # #<-factor->strg <Name> # # <Name> # # ***
COPY 501 OUTPUT MEAN 1 1 48.4 DISPLY 1 INPUT TIMSER 1

```

```

<-Volume-> <-Grp> <-Member-><--Mult-->Tran <-Target vols> <-Grp> <-Member-> ***
<Name> # <Name> # #<-factor->strg <Name> # # <Name> # # ***
END NETWORK

```

RCHRES

GEN-INFO

```

RCHRES          Name          Nexits  Unit Systems  Printer          ***
# - #<-----><----> User T-series Engl Metr LKFG          ***
                               in out          ***
1      Vault 1                1      1      1      1      28      0      1
2      Trapezoidal Pond-032    1      1      1      1      28      0      1

```

END GEN-INFO

*** Section RCHRES***

ACTIVITY

```

<PLS > ***** Active Sections *****
# - # HYFG ADFG CNFG HTFG SDFG GQFG OXFG NUFQ PKFG PHFG ***
1      1      0      0      0      0      0      0      0      0      0
2      1      0      0      0      0      0      0      0      0      0

```

END ACTIVITY

PRINT-INFO

```

<PLS > ***** Print-flags ***** PIVL PYR *****
# - # HYDR ADCA CONS HEAT SED GQL OXRX NUTR PLNK PHCB PIVL PYR *****
1      4      0      0      0      0      0      0      0      0      0      1      9
2      4      0      0      0      0      0      0      0      0      0      1      9

```

END PRINT-INFO

HYDR-PARM1

```

RCHRES  Flags for each HYDR Section          ***
# - # VC A1 A2 A3 ODFVFG for each *** ODGTFG for each FUNCT for each
      FG FG FG FG possible exit *** possible exit possible exit
      * * * * * * * * * * * * * * * * * * * * * * * * * * * * * * * * * *
1      0 1 0 0      4 0 0 0 0 0      0 0 0 0 0 0      2 2 2 2 2
2      0 1 0 0      4 0 0 0 0 0      0 0 0 0 0 0      2 2 2 2 2

```

END HYDR-PARM1

HYDR-PARM2

```

# - # FTABNO          LEN          DELTH          STCOR          KS          DB50          ***
<-----><-----><-----><-----><-----><-----><----->          ***
1      1          0.03          0.0          0.0          0.5          0.0
2      2          0.02          0.0          0.0          0.5          0.0

```

END HYDR-PARM2

HYDR-INIT

```

RCHRES  Initial conditions for each HYDR section          ***
# - # *** VOL          Initial value of COLIND          Initial value of OUTDGT
      *** ac-ft          for each possible exit          for each possible exit
<-----><----->          <-----><-----><-----><-----><----->          *** <-----><-----><-----><-----><----->
1      0          4.0 0.0 0.0 0.0 0.0          0.0 0.0 0.0 0.0 0.0

```

2 0 4.0 0.0 0.0 0.0 0.0 0.0 0.0 0.0 0.0 0.0

END HYDR-INIT
 END RCHRES

SPEC-ACTIONS
 END SPEC-ACTIONS
 FTTABLES

FTABLE	1	92	4	Depth (ft)	Area (acres)	Volume (acre-ft)	Outflow1 (cfs)	Velocity (ft/sec)	Travel Time*** (Minutes)***
0.000000	0.496074	0.000000	0.000000						
0.047778	0.496074	0.023701	0.013704						
0.095556	0.496074	0.047403	0.019381						
0.143333	0.496074	0.071104	0.023737						
0.191111	0.496074	0.094805	0.027409						
0.238889	0.496074	0.118507	0.030644						
0.286667	0.496074	0.142208	0.033569						
0.334444	0.496074	0.165909	0.036258						
0.382222	0.496074	0.189611	0.038762						
0.430000	0.496074	0.213312	0.041113						
0.477778	0.496074	0.237013	0.043337						
0.525556	0.496074	0.260715	0.045452						
0.573333	0.496074	0.284416	0.047473						
0.621111	0.496074	0.308117	0.049412						
0.668889	0.496074	0.331819	0.051277						
0.716667	0.496074	0.355520	0.053077						
0.764444	0.496074	0.379221	0.054817						
0.812222	0.496074	0.402923	0.056505						
0.860000	0.496074	0.426624	0.058143						
0.907778	0.496074	0.450325	0.059736						
0.955556	0.496074	0.474027	0.061288						
1.003333	0.496074	0.497728	0.062801						
1.051111	0.496074	0.521429	0.064279						
1.098889	0.496074	0.545131	0.065724						
1.146667	0.496074	0.568832	0.067137						
1.194444	0.496074	0.592533	0.068522						
1.242222	0.496074	0.616235	0.069879						
1.290000	0.496074	0.639936	0.071210						
1.337778	0.496074	0.663637	0.072517						
1.385556	0.496074	0.687339	0.073800						
1.433333	0.496074	0.711040	0.075062						
1.481111	0.496074	0.734741	0.076303						
1.528889	0.496074	0.758443	0.077524						
1.576667	0.496074	0.782144	0.078726						
1.624444	0.496074	0.805845	0.079909						
1.672222	0.496074	0.829547	0.081076						
1.720000	0.496074	0.853248	0.082226						
1.767778	0.496074	0.876949	0.083360						
1.815556	0.496074	0.900651	0.084748						
1.863333	0.496074	0.924352	0.087767						
1.911111	0.496074	0.948053	0.091699						
1.958889	0.496074	0.971755	0.096260						
2.006667	0.496074	0.995456	0.101312						
2.054444	0.496074	1.019157	0.106769						
2.102222	0.496074	1.042859	0.112566						
2.150000	0.496074	1.066560	0.118653						
2.197778	0.496074	1.090261	0.124990						
2.245556	0.496074	1.113963	0.131544						
2.293333	0.496074	1.137664	0.138284						
2.341111	0.496074	1.161365	0.145186						
2.388889	0.496074	1.185067	0.152226						
2.436667	0.496074	1.208768	0.159384						
2.484444	0.496074	1.232469	0.166641						
2.532222	0.496074	1.256171	0.173980						
2.580000	0.496074	1.279872	0.181384						
2.627778	0.496074	1.303573	0.188838						
2.675556	0.496074	1.327275	0.196329						
2.723333	0.496074	1.350976	0.203844						
2.771111	0.496074	1.374677	0.211370						

2.818889	0.496074	1.398379	0.219434
2.866667	0.496074	1.422080	0.228446
2.914444	0.496074	1.445781	0.237635
2.962222	0.496074	1.469483	0.246997
3.010000	0.496074	1.493184	0.256528
3.057778	0.496074	1.516885	0.266225
3.105556	0.496074	1.540587	0.276084
3.153333	0.496074	1.564288	0.286104
3.201111	0.496074	1.587989	0.355237
3.248889	0.496074	1.611691	0.368609
3.296667	0.496074	1.635392	0.382183
3.344444	0.496074	1.659093	0.532973
3.392222	0.496074	1.682795	0.829622
3.440000	0.496074	1.706496	1.215079
3.487778	0.496074	1.730197	1.666915
3.535556	0.496074	1.753899	2.167461
3.583333	0.496074	1.777600	2.699612
3.631111	0.496074	1.801301	3.245821
3.678889	0.496074	1.825003	3.788201
3.726667	0.496074	1.848704	4.309169
3.774444	0.496074	1.872405	4.792441
3.822222	0.496074	1.896107	5.224280
3.870000	0.496074	1.919808	5.594941
3.917778	0.496074	1.943509	5.900297
3.965556	0.496074	1.967211	6.143608
4.013333	0.496074	1.990912	6.337431
4.061111	0.496074	2.014613	6.578119
4.108889	0.496074	2.038315	6.769957
4.156667	0.496074	2.062016	6.956226
4.204444	0.496074	2.085717	7.137384
4.252222	0.496074	2.109419	7.313833
4.300000	0.496074	2.133120	7.485922
4.347778	0.496074	2.156821	7.653960

END FTABLE 1
 FTABLE 2

91 4

Depth (ft)	Area (acres)	Volume (acre-ft)	Outflowl (cfs)	Velocity (ft/sec)	Travel Time*** (Minutes)***
0.000000	0.091753	0.000000	0.000000		
0.083333	0.093434	0.007716	0.010360		
0.166667	0.095127	0.015573	0.014651		
0.250000	0.096832	0.023571	0.017944		
0.333333	0.098548	0.031712	0.020720		
0.416667	0.100275	0.039996	0.023166		
0.500000	0.102014	0.048425	0.025377		
0.583333	0.103765	0.056999	0.027410		
0.666667	0.105527	0.065720	0.029303		
0.750000	0.107300	0.074587	0.031080		
0.833333	0.109085	0.083604	0.032762		
0.916667	0.110882	0.092769	0.034361		
1.000000	0.112689	0.102084	0.035888		
1.083333	0.114509	0.111551	0.037354		
1.166667	0.116340	0.121170	0.038764		
1.250000	0.118182	0.130941	0.040124		
1.333333	0.120036	0.140867	0.041440		
1.416667	0.121901	0.150948	0.042716		
1.500000	0.123778	0.161184	0.043954		
1.583333	0.125666	0.171578	0.045159		
1.666667	0.127565	0.182129	0.046332		
1.750000	0.129477	0.192839	0.047476		
1.833333	0.131399	0.203709	0.048593		
1.916667	0.133333	0.214739	0.049685		
2.000000	0.135279	0.225932	0.050754		
2.083333	0.137236	0.237286	0.051800		
2.166667	0.139205	0.248805	0.052826		
2.250000	0.141185	0.260488	0.053833		
2.333333	0.143176	0.272336	0.054820		
2.416667	0.145179	0.284351	0.055791		
2.500000	0.147194	0.296533	0.056745		
2.583333	0.149219	0.308884	0.057683		

2.666667	0.151257	0.321403	0.058606
2.750000	0.153306	0.334094	0.059514
2.833333	0.155366	0.346955	0.060409
2.916667	0.157438	0.359988	0.061291
3.000000	0.159521	0.373195	0.062161
3.083333	0.161616	0.386576	0.063018
3.166667	0.163722	0.400132	0.063864
3.250000	0.165840	0.413863	0.064699
3.333333	0.167969	0.427772	0.065523
3.416667	0.170110	0.441859	0.066337
3.500000	0.172262	0.456124	0.067141
3.583333	0.174426	0.470570	0.067936
3.666667	0.176601	0.485196	0.068616
3.750000	0.178788	0.500004	0.102647
3.833333	0.180986	0.514994	0.113838
3.916667	0.183196	0.530168	0.122971
4.000000	0.185417	0.545527	0.130921
4.083333	0.187649	0.561072	0.138078
4.166667	0.189893	0.576803	0.144654
4.250000	0.192149	0.592721	0.160608
4.333333	0.194416	0.608828	0.170824
4.416667	0.196694	0.625124	0.179649
4.500000	0.198984	0.641611	0.187676
4.583333	0.201286	0.658289	0.195140
4.666667	0.203598	0.675159	0.202171
4.750000	0.205923	0.692222	0.208851
4.833333	0.208259	0.709480	0.215236
4.916667	0.210606	0.726932	0.221369
5.000000	0.212965	0.744581	0.227280
5.083333	0.215335	0.762427	0.232995
5.166667	0.217717	0.780471	0.238535
5.250000	0.220110	0.798714	0.243916
5.333333	0.222515	0.817156	0.249154
5.416667	0.224931	0.835800	0.254259
5.500000	0.227359	0.854645	0.259243
5.583333	0.229798	0.873694	0.264114
5.666667	0.232249	0.892946	0.268881
5.750000	0.234711	0.912402	0.273549
5.833333	0.237184	0.932064	0.278127
5.916667	0.239669	0.951933	0.282619
6.000000	0.242166	0.972010	0.287029
6.083333	0.244674	0.992295	0.291364
6.166667	0.247194	1.012789	0.295626
6.250000	0.249725	1.033494	0.299820
6.333333	0.252267	1.054411	0.303948
6.416667	0.254821	1.075539	0.308015
6.500000	0.257386	1.096881	0.312023
6.583333	0.259963	1.118437	0.698266
6.666667	0.262552	1.140209	1.394140
6.750000	0.265152	1.162197	2.262147
6.833333	0.267763	1.184401	3.210032
6.916667	0.270386	1.206824	4.143880
7.000000	0.273020	1.229466	4.974055
7.083333	0.275666	1.252328	5.632565
7.166667	0.278323	1.275411	6.096732
7.250000	0.280992	1.298716	6.417490
7.333333	0.283672	1.322243	6.818561
7.416667	0.286364	1.345995	7.137813
7.500000	0.289067	1.369971	7.442974

END FTABLE 2

END FTABLES

EXT SOURCES

<-Volume->	<Member>	SsysSgap<--Mult-->	Tran	<-Target vols>	<-Grp>	<-Member->	***
<Name>	#	<Name>	#	tem strg<-factor->	strg	<Name>	# #
WDM	2	PREC	ENGL	1	PERLND	1 999 EXTNL	PREC
WDM	2	PREC	ENGL	1	IMPLND	1 999 EXTNL	PREC
WDM	1	EVAP	ENGL	1	PERLND	1 999 EXTNL	PETINP
WDM	1	EVAP	ENGL	1	IMPLND	1 999 EXTNL	PETINP

END EXT SOURCES

EXT TARGETS

<-Volume->	<-Grp>	<-Member->	<--Mult-->	Tran	<-Volume->	<Member>	Tsys	Tgap	Amd	***	
<Name>	#	<Name>	#	#<-factor->	strg	<Name>	#	<Name>	tem	strg	strg***
RCHRES	1	HYDR	RO	1	1	1	WDM	1000	FLOW	ENGL	REPL
RCHRES	1	HYDR	STAGE	1	1	1	WDM	1001	STAG	ENGL	REPL
COPY	1	OUTPUT	MEAN	1	1	48.4	WDM	701	FLOW	ENGL	REPL
COPY	501	OUTPUT	MEAN	1	1	48.4	WDM	801	FLOW	ENGL	REPL
COPY	601	OUTPUT	MEAN	1	1	48.4	WDM	901	FLOW	ENGL	REPL
RCHRES	2	HYDR	RO	1	1	1	WDM	1004	FLOW	ENGL	REPL
RCHRES	2	HYDR	STAGE	1	1	1	WDM	1005	STAG	ENGL	REPL

MASS-LINK

<Volume>	<-Grp>	<-Member->	<--Mult-->	<Target>	<-Grp>	<-Member->	***
<Name>	#	<Name>	#	#<-factor->	<Name>	<Name>	# #***
MASS-LINK		2					
PERLND	PWATER	SURO		0.083333	RCHRES	INFLOW	IVOL
END MASS-LINK		2					
MASS-LINK		3					
PERLND	PWATER	IFWO		0.083333	RCHRES	INFLOW	IVOL
END MASS-LINK		3					
MASS-LINK		5					
IMPLND	IWATER	SURO		0.083333	RCHRES	INFLOW	IVOL
END MASS-LINK		5					
MASS-LINK		12					
PERLND	PWATER	SURO		0.083333	COPY	INPUT	MEAN
END MASS-LINK		12					
MASS-LINK		13					
PERLND	PWATER	IFWO		0.083333	COPY	INPUT	MEAN
END MASS-LINK		13					
MASS-LINK		14					
PERLND	PWATER	AGWO		0.083333	COPY	INPUT	MEAN
END MASS-LINK		14					
MASS-LINK		15					
IMPLND	IWATER	SURO		0.083333	COPY	INPUT	MEAN
END MASS-LINK		15					
MASS-LINK		16					
RCHRES	ROFLOW				COPY	INPUT	MEAN
END MASS-LINK		16					

END MASS-LINK

END RUN

Predeveloped HSPF Message File

Mitigated HSPF Message File

Disclaimer

Legal Notice

This program and accompanying documentation are provided 'as-is' without warranty of any kind. The entire risk regarding the performance and results of this program is assumed by End User. Clear Creek Solutions Inc. and the governmental licensee or sublicensees disclaim all warranties, either expressed or implied, including but not limited to implied warranties of program and accompanying documentation. In no event shall Clear Creek Solutions Inc. be liable for any damages whatsoever (including without limitation to damages for loss of business profits, loss of business information, business interruption, and the like) arising out of the use of, or inability to use this program even if Clear Creek Solutions Inc. or their authorized representatives have been advised of the possibility of such damages. Software Copyright © by : Clear Creek Solutions, Inc. 2005-2023; All Rights Reserved.

Clear Creek Solutions, Inc.
6200 Capitol Blvd. Ste F
Olympia, WA. 98501
Toll Free 1(866)943-0304
Local (360)943-0304

www.clearcreeksolutions.com

Impervious Surface Table



Complete the following table as applicable to the proposed project (include onsite and offsite improvements):

Description ^a	Onsite	Offsite	Total
Existing Conditions			
Total Project Area ^b (ft ²)	268,786	17,883	286,669
Existing hard surface (ft ²)	86,084	12,457	98,541
Existing vegetation area (ft ²)	182,702	5,426	188,128
Proposed Conditions			
Total Project Area ^b (ft ²)	268,786	17,883	286,669
Amount of new hard surface (ft ²)	153,684	10,399	164,083
Amount of new pollution generating hard surface (PGHS) ^c (ft ²)	78,135	2,522	80,657
Amount of replaced hard surface (ft ²)	0	0	0
Amount of replaced PGHS ^d (ft ²)	0	0	0
Amount of new plus replaced hard surface (ft ²)	153,684	10,399	164,083
Amount of new + replaced PGHS (ft ²)	78,135	2,522	80,657
Amount of existing hard surfaces converted to vegetation (ft ²)	13,343	7,055	20,398
Amount of Land Disturbed (ft ²)	262,395	17,883	280,278
Vegetation to Lawn/Landscaped (acres)	1.688	0.010	1.698
Native Vegetation to Pasture (acres)	0	0	0
Existing hard surface to remain unaltered (ft ²)	0	0	0
Existing vegetation area to remain unaltered (ft ²)	6,391	0	6,391

a. All terms are defined in the 2019 Ecology Manual glossary.

b. The total project area in the existing condition should typically match the total project area in the proposed condition.

c. The "amount of new PGHS" should be part of or all of "amount of new hard surfaces"

d. The "amount of replaced PGHS" should be part of or all of the "amount of replaced hard surfaces".