

PRELIMINARY STORM DRAINAGE REPORT

FOR

**1200 7th Ave SE Townhomes
Puyallup, Washington**

June 2024

**Prepared for:
Vitaly Kravchishin**

**Prepared by:
Daniel Smith, P.E., Project Manager
429 29th Street NE, Suite D
Puyallup, WA 98372
(253) 848-4282**

**Approved By:
Daniel Smith, P.E., Senior Project Manager**

REPORT #19078.1



“I hereby state that this Drainage and Erosion/Sediment Control Plan for the 1200 7th Ave SE Townhomes project has been prepared by me or under my supervision and meets the standard of care and expertise which is usual and customary in this community of professional engineers. I understand that City of Puyallup does not and will not assume liability for the sufficiency, suitability or performance of drainage facilities prepared by me.”

This analysis is based on data and records either supplied to, or obtained by, C.E.S. NW, Inc. These documents are referenced within the text of the analysis. The analysis has been prepared utilizing procedures and practices within the standard accepted practices of the industry.

TABLE OF CONTENTS

PAGE

TABLE OF CONTENTS	1
STORM DRAINAGE	1
1. PROJECT OVERVIEW	1
2. EXISTING CONDITIONS SUMMARY	2
3. OFF-SITE ANALYSIS REPORT.....	3
4. PERMANENT STORMWATER CONTROL PLAN	3
5. DISCUSSION OF MINIMUM REQUIREMENTS	4
APPENDIX A GENERAL EXHIBITS	
VICINITY MAP	A-1
SOILS MAP AND DESCRIPTION (NRCS).....	A-2
APPENDIX B BASIN EXHIBITS	
PREDEVELOPED BASIN MAP	B-1
POST DEVELOPED BASIN MAP.....	B-2
DOWNSTREAM CONDITION MAP.....	B-3
FIRM PANEL (#53053C0342E)	B-4
APPENDIX C COMPUTER PRINTOUTS	
WWHM MODELING RESULTS.....	C-1
APPENDIX D OTHER REPORT	
GEOTECHNICAL REPORT.....	D-1

STORM DRAINAGE

1. Project Overview

This report accompanies the preliminary site plan, as submitted to the City of Puyallup for review and approval. This document provides site information, and the analysis used to prepare the storm drainage design for the 1200 7th Ave SE Townhome project. The *Washington State Department of Ecology Stormwater Management Manual for Western Washington, 2019 (Manual)*, and the City of Puyallup's modifications to that document establishes the methodology and design criteria used for this project.

The 1200 7th Ave SE Townhome project proposes 6 townhomes on a 0.48-acre parcel (7845001330). The project site is accessed from 7th Ave SE with a new commercial driveway approach. The project is located in the Puyallup River Water Resources Inventory Area (WRIA 10). The Vicinity Map has been included in Appendix 'A' of this report. A project summary is as follows:

Permit Applied for – Preliminary Site Plan

Address – 1200 7th Ave SE Puyallup, WA 98372

Parcel Numbers – 7845001330

Legal description – (Per statutory warranty deed filed under recording number 201910110806).

The west 33 feet of block 77, and the east 50 feet of block 78, Frank R. Spinning's first addition to the Town of Puyallup, according to the plat thereof recorded in Book 4 of Plats, page 86, in Pierce County, Washington.

Situate in the County of Pierce, State of Washington.

The property has historically been used as a single-family residence. Currently there is a single-family residence, a detached garage and sheds on site as depicted on the pre-developed basin map (Appendix 'B'). The existing house and garage are to be removed when construction permits are approved. The property has frontage along 7th Ave SE, which provides access to 6 units from a temporary asphalt driveway approach. Frontage improvements are not proposed since the City

has a capital improvement project 7th Ave SE which is to be completed in the near future. A fee in-lieu of frontage improvements will be paid to the City. Sewer, water, and stormwater improvements will be permitted under the site development permit. The project site proposes approximately 4,708 sq.ft. of rooftops, 6,586 sq.ft. of pavement, patios and walkways; therefore, according to Figure 2.4.1 of Volume I of the Manual, the project must evaluate all minimum requirements; see Section 5 of this report for a detailed discussion of each of the minimum requirements. A detention tank is proposed in the northern portion of the site for flow control. The project proposes 4,984 sq.ft. of pollution generating impervious surfaces (PGIS); therefore, runoff treatment is not required. Perforated stub-outs are proposed to connect the rooftops to the tank. All disturbed areas which are not converted to impervious surface will have soil amended (BMP T5.13).

2. Existing Conditions Summary

In the existing condition, the site is used as a single-family residence and yard. The existing topography is relatively flat with elevations between 53-54 (NAVD 88) and gradually slopes towards 7th Ave SE. Stormwater runoff from this site is currently collected by a closed conveyance system within 7th Ave SE which consists of a 30-inch concrete storm line on the north side of the roadway. Current site accessed is provided by a gravel driveway approach from 7th Ave SE which will be replaced with a temporary asphalt driveway approach as part of the site development permit.

Onsite soils have been identified as Puyallup fine sandy loam (31A a Type B soil) determined by the USDA SCS maps of Pierce County, Washington. A description of the USDA soils and a copy of the soil map for this portion of Pierce County have been included in Appendix 'A' of this report. A geotechnical engineer's report has been prepared by ESNW, dated April 9, 2020 and updated January 21, 2021, which documents poorly graded sands with fine content up to 87.50% across six test pits. Groundwater seepage observed at a depth between 3.5-feet to 5-feet. A small-scale PIT was performed in TP-5 at a depth of 3.5-feet and an infiltration rate was measured at 0-inches per hour. A copy of the geotechnical report is included in Appendix 'D'.

There is an existing gravity sewer main in 23rd Avenue Southwest, which will service the properties. There are no known aquifer recharge or wellhead protection areas that affect this

property. There are no known well or septic systems onsite. If a septic system or well is discovered onsite during construction, it will be decommissioned per Tacoma-Pierce County Health Department standards. The parcel and all the proposed improvements are located within Zone X, which is considered outside of the 100-year floodplain, per FEMA Map # 53053C0342E. A copy of the FIRM Panel map can be found in Appendix 'B' of this report.

3. Off-site Analysis Report

A quarter mile downstream analysis is required by the City of Puyallup. The project proposed an onsite detention tank to mitigate stormwater runoff from the post-developed site. The tank's riser releases stormwater matching 50 percent of the predeveloped 2-year storm event up to the predeveloped 50-year storm event, which discharges to a 30-inch public conveyance system on the north side of 7th Ave SE. Based on public GIS information, the runoff is conveyed west within 7th Ave SE towards 10th Street SE and an overpass with SR 512. The runoff outfalls to a 72-inch WSDOT conveyance pipe that flows north along SR 512. The ¼ mile drainage path concludes in WSDOT right-of-way. The runoff ultimately outfalls to the Puyallup River approximately 0.7 miles downstream of the site. A downstream map is included in Appendix 'B'. No adverse impacts are anticipated to the downstream system as a result of the development due to the proposed detention tank and bio-swale.

4. Permanent Stormwater Control Plan

Existing Site Hydrology

The existing site slopes towards 7th Ave SE as sheet flow. For pond sizing purposes the pre-developed basin (.491-acres) is modeled as a flat forested condition for C type soils.

The following is a summary of the pre-developed flow rates:

2-year.....	0.011-cfs
10-year.....	0.021-cfs
50-year.....	0.027-cfs
100-year.....	0.029-cfs

Please refer to the Appendix 'B' for more information of the existing site.

Developed Site Hydrology

Under the developed condition, the project site proposes approximately 4,708 sq.ft. of rooftops, 6,586 sq.ft. of pavement, patios and walkways. The landscape and yard areas can be modeled as “pasture” due to soil amendment per Ecology BMP T5.13. The runoff from rooftops will connect to the detention tank with a perforated stub-outs BMP T5.10C. The post developed basin is summarized in the below:

Sub-Basin	Land-use	WWHM Description	Area (acre)
Basin A	Landscaping (Amended Soils)	C, Pasture, Flat.	0.187
Basin B	Parking Lot and Walkways	Parking Lot, Flat	0.128
Basin C	Rooftops	Rooftops Flat	0.108
Bypass A	Landscaping (Amended Soils)	C, Pasture, Mod.	0.044
Bypass B	Driveway Approach	Parking Lot, Mod.	0.018
Bypass C	Walkway	Sidewalk, Flat	0.006
Total			0.491

Table 1 – Post Developed Basin

Storm Event	Pre-Developed Flow Rate (cfs)	Mitigated Flow Rate (cfs)
2	0.011	0.012
5	0.017	0.017
10	0.021	0.021
25	0.024	0.026
50	0.027	0.031
100	0.029	0.037

Table 2 –Flow Rate Summary

An 18-inch open top flat riser with three orifices is provided to control the mitigated discharge rates from the detention tank (facility). The following is a summary of the riser schedule:

Elevation	Type	Size.
48.00	Orifice	0.250-in
52.87	Orifice	0.500-in
53.66	Orifice	0.750-in

Table 3 – Pond Riser Schedule

Facility Sizing

The detention tank is designed to release stormwater matching 50 percent of 2-year storm event up to the 50-year storm event of the predeveloped site’s condition. As modelled by the WWHM computer program, the detention tank requires 514-linear feet of 5-foot diameter tank with a 4-foot riser. Since the project proposes less than 5,000 sq.ft. of PGIS it is exempt from runoff treatment. WWHM modeling report is included in Appendix ‘C’.

Conveyance Calculations

The project proposes an onsite closed conveyance system with catch basins, PVC and ductile iron pipes. To demonstrate the system’s capacity the shallowest pipe’s is analyzed with the manning’s equation and the total site’s 100-year storm event as calculated by the WWHM computer program. The pipe analyzed is 50-linear foot ductile iron pipe that connects to the existing storm system in 7th Ave SE. Computer modeling results are provided in Appendix ‘C’. A summary of the calculations is provided below:

- Pipe Reach Name: **Pipe 1**
- Structure Tributary Area: **0.446-ac**
- Pipe Diameter (in): **12-in**
- Pipe Length (ft): **50-ft**
- Pipe Slope (%): **1.62 %**
- Manning’s Coefficient (n): **0.012 (DI CL50)**
- Design Flow (cfs): **0.22-cfs (100-year)**
- Pipe-Full Flow (cfs): **2.73-cfs**
- Water Depth at Design Flow (in): **2.4-inches**
- Critical Depth (in): **2.4-inches**
- Velocity at Design Flow (fps): **1.95-fps**
- Velocity at Pipe-Full Flow (fps): **3.47-fps**
- Percent full at Design Flow (%): **15%**
- HGL for each Pipe Reach (elev): **50.03-feet**

5. Discussion of Minimum Requirements

The project proposes more than 5,000 sq.ft. of impervious surfaces; therefore, as required by Figure I-3.1 of Volume I of the Manual each minimum requirement applies.

Figure I-3.1: Flow Chart for Determining Requirements for New Development

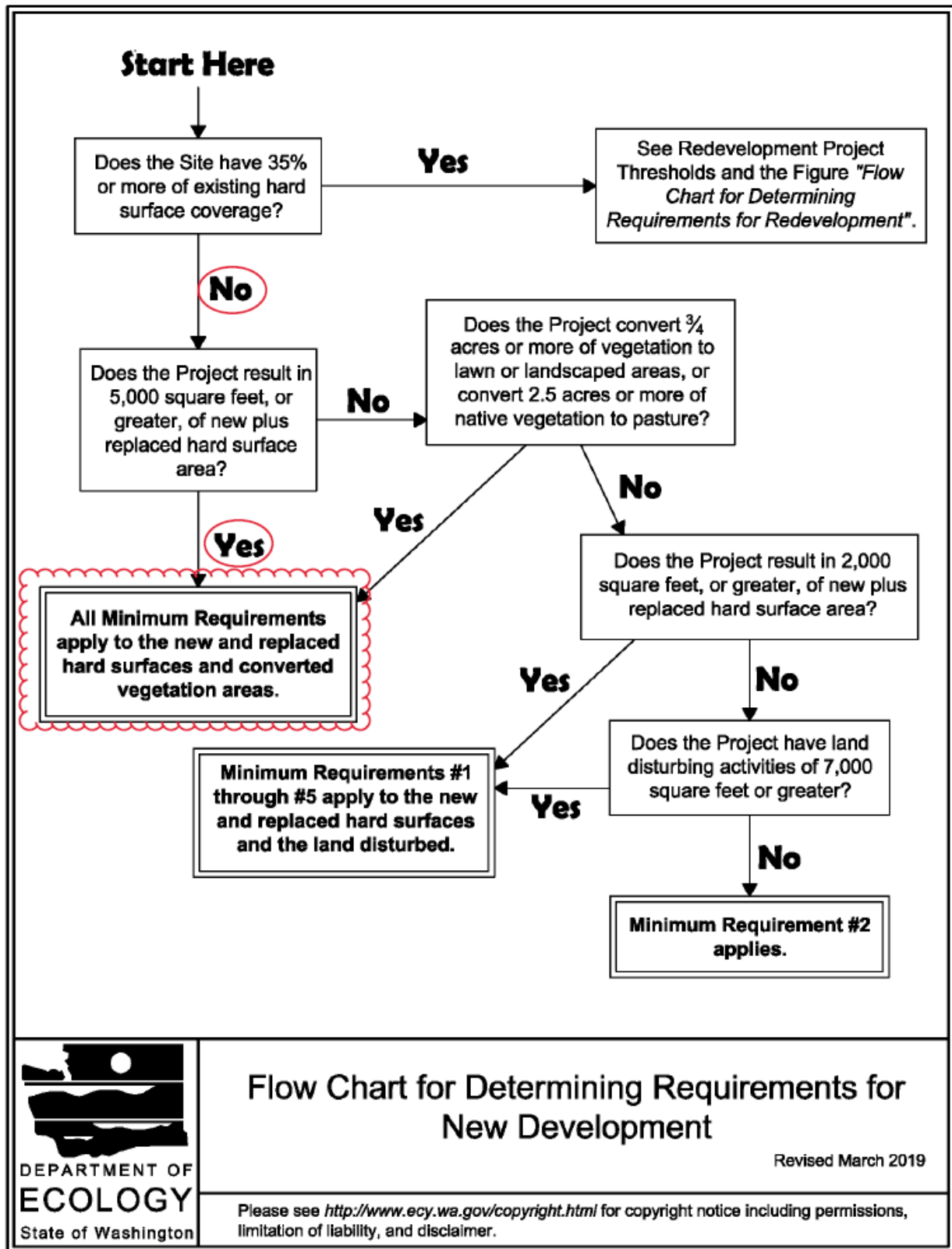

Flow Chart for Determining Requirements for New Development

Revised March 2019

Please see <http://www.ecy.wa.gov/copyright.html> for copyright notice including permissions, limitation of liability, and disclaimer.

The following is a summary of the minimum requirements as described in Section I-3.3 of Volume I of the Manual.

5.1 Minimum Requirement #1: Preparation of a Stormwater Site Plan

The Stormwater Site Plan is prepared and is provided with this document.

5.2 Minimum Requirement #2: Construction Stormwater Pollution Prevention (SWPP)

A SWPP Plan addressing all 13 elements will be provided as part of the final engineering submittal.

5.3 Minimum Requirement #3: Source Control of Pollution

Permanent source control BMPs are required for the development's daily operations, and the stormwater facilities must be maintained as described in the Operations and Maintenance Manual, which will be provided as part of the final engineering submittal.

5.4 Minimum Requirement #4: Preservation of Natural Drainage System and Outfalls

Under existing conditions, stormwater runoff is discharged into the public conveyance system on the north side of 7th Avenue Southeast. After being detained by the proposed tanks runoff will continue to be discharged to the public conveyance system.

5.5 Minimum Requirement #5: Onsite Stormwater Management

This project must meet minimum requirements 1-9 and is not flow control exempt; therefore, this project will evaluate BMP from List #2 for onsite stormwater management compliance. BMPs from List 2 were evaluated as follows:

Lawn and Landscape Areas

- **Soil Preservation and Amendment (Ecology BMP T5.13)**, all disturbed areas which are not converted to impervious areas shall apply soil amendment per Ecology BMP T5.13.

Roof Areas

- **Full Dispersion (BMP T5.20)** is deemed **infeasible** since the required forested or native condition is not available on site.
- **Downspout Infiltration (BMP T5.10A)** is deemed **infeasible** since the measured infiltration rate is 0-inches per hour.

- **Bioretention (BMP T7.30)** is deemed **infeasible** since the measured infiltration rate is 0-inches per hour.
- **Downspout Dispersion Systems (BMP T5.10B)** is deemed **infeasible** since 25-foot flow paths and trench sizes cannot be provided onsite.
- **Perforated Stub-out Connections (BM T5.10C)** are deemed **feasible** above elevation of 51.50 (NAVD 88) and are proposed for the rooftops.

Other Hard Surfaces

- **Full Dispersion (BMP T5.20)** is deemed **infeasible** since the required forested or native condition is not available on site.
- **Permeable Pavement (BMP T5.15) and Bioretention (BMP T7.30)** are deemed **infeasible** since the measured infiltration rate is 0-inches per hour.
- **Sheet Flow Dispersion (T5.12) and Concentrated Flow Dispersion (BMP T5.11)** are deemed **infeasible** for the parking lot since the minimum flow paths are not available onsite. No other BMPs are required for this surface type.

5.6 Minimum Requirement #6: Runoff Treatment

The project proposes less than 5,000 square feet of pollution generating impervious surfaces (PGIS); therefore, minimum requirement #6 is not applicable to this project.

5.7 Minimum Requirement #7: Flow Control

Detention tanks located under the parking lot are proposed for flow control. The detention tanks are sized with WWHM modeling program to match a pre-developed forested condition between ½ 2-year to the full 50-year storm events.

5.8 Minimum Requirement #8: Wetlands Protection

This requirement is not applicable to the project since there are no existing wetlands onsite or adjacent to the site.

5.9 Minimum Requirement #9: Operation and Maintenance

An Operation and Maintenance Manual will be provided as part of the final engineering submittal.

6. Other Permits

Other necessary permits and approvals include:

- SEPA
- Building Permits
-
- Right of Way
- Sanitary Side Sewer Permits
- Water Service Permits
- PSE

APPENDIX A

General Exhibits

Vicinity Map

A-1

Soils Map and Description (NRCS)

A-2



VICINITY MAP

Soil Map—Pierce County Area, Washington

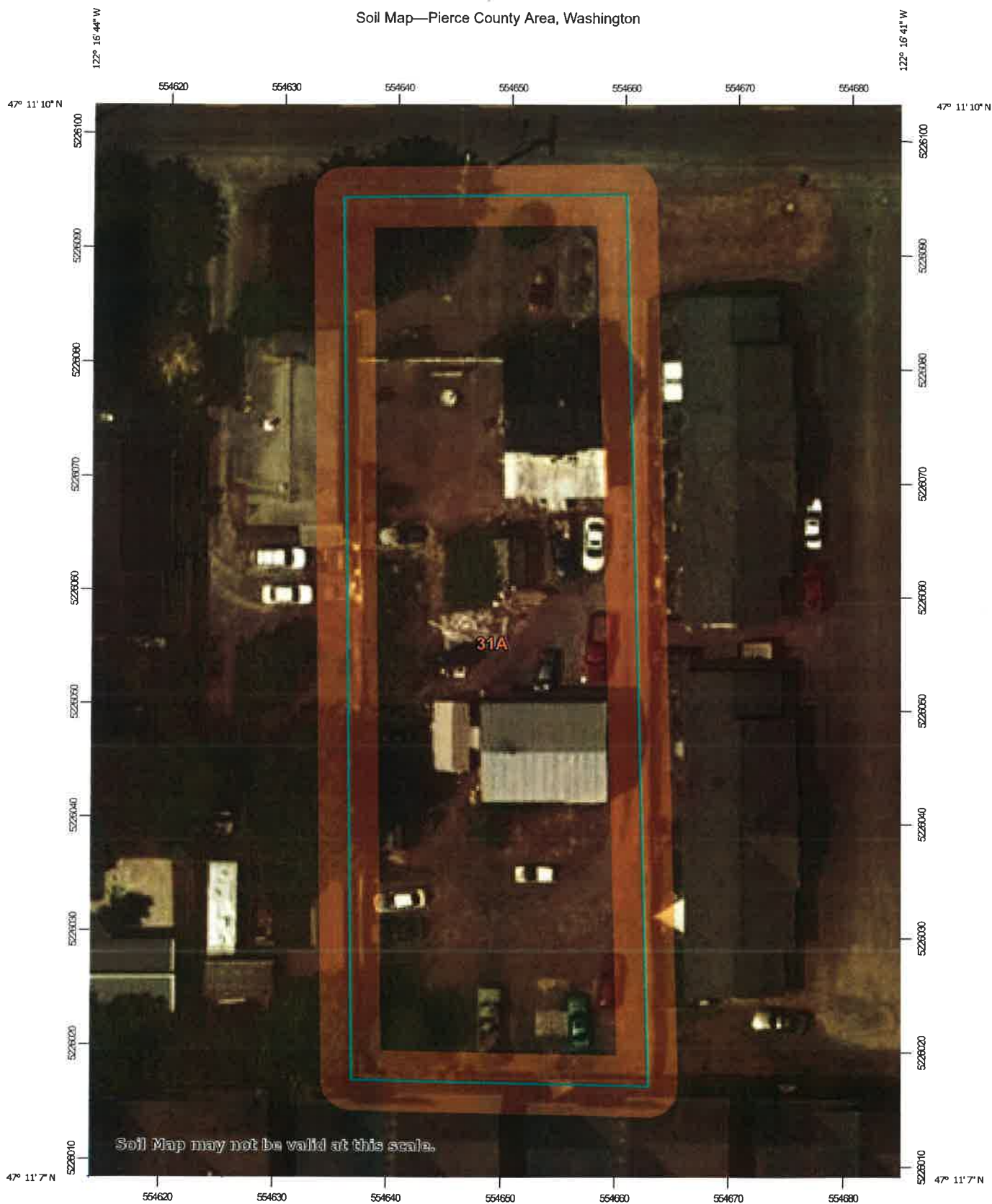

Map Scale: 1:458 if printed on A portrait (8.5" x 11") sheet.





































0 5 10 20 30 Meters

0 20 40 80 120 Feet

Map projection: Web Mercator Corner coordinates: WGS84 Edge tics: UTM Zone 10N WGS84



MAP LEGEND

- Area of Interest (AOI)**
-  Area of Interest (AOI)
- Soils**
-  Soil Map Unit Polygons
-  Soil Map Unit Lines
-  Soil Map Unit Points
- Special Point Features**
-  Blowout
-  Borrow Pit
-  Clay Spot
-  Closed Depression
-  Gravel Pit
-  Gravelly Spot
-  Landfill
-  Lava Flow
-  Marsh or swamp
-  Mine or Quarry
-  Miscellaneous Water
-  Perennial Water
-  Rock Outcrop
-  Saline Spot
-  Sandy Spot
-  Severely Eroded Spot
-  Sinkhole
-  Slide or Slip
-  Sodic Spot
-  Spoil Area
-  Stony Spot
-  Very Stony Spot
-  Wet Spot
-  Other
-  Special Line Features
- Water Features**
-  Streams and Canals
- Transportation**
-  Rails
-  Interstate Highways
-  US Routes
-  Major Roads
-  Local Roads
- Background**
-  Aerial Photography

MAP INFORMATION

The soil surveys that comprise your AOI were mapped at 1:24,000.

Warning: Soil Map may not be valid at this scale.

Enlargement of maps beyond the scale of mapping can cause misunderstanding of the detail of mapping and accuracy of soil line placement. The maps do not show the small areas of contrasting soils that could have been shown at a more detailed scale.

Please rely on the bar scale on each map sheet for map measurements.

Source of Map: Natural Resources Conservation Service
 Web Soil Survey URL:
 Coordinate System: Web Mercator (EPSG:3857)

Maps from the Web Soil Survey are based on the Web Mercator projection, which preserves direction and shape but distorts distance and area. A projection that preserves area, such as the Albers equal-area conic projection, should be used if more accurate calculations of distance or area are required.

This product is generated from the USDA-NRCS certified data as of the version date(s) listed below.

Soil Survey Area: Pierce County Area, Washington
 Survey Area Data: Version 14, Sep 10, 2018

Soil map units are labeled (as space allows) for map scales 1:50,000 or larger.

Date(s) aerial images were photographed: Jul 8, 2014—Jul 15, 2014

The orthophoto or other base map on which the soil lines were compiled and digitized probably differs from the background imagery displayed on these maps. As a result, some minor shifting of map unit boundaries may be evident.

Map Unit Legend

Map Unit Symbol	Map Unit Name	Acres in AOI	Percent of AOI
31A	Puyallup fine sandy loam	0.5	100.0%
Totals for Area of Interest		0.5	100.0%

Pierce County Area, Washington

31A—Puyallup fine sandy loam

Map Unit Setting

National map unit symbol: 2hq9

Elevation: 0 to 390 feet

Mean annual precipitation: 35 to 60 inches

Mean annual air temperature: 50 degrees F

Frost-free period: 170 to 200 days

Farmland classification: All areas are prime farmland

Map Unit Composition

Puyallup and similar soils: 85 percent

Minor components: 2 percent

Estimates are based on observations, descriptions, and transects of the mapunit.

Description of Puyallup

Setting

Landform: Flood plains, terraces

Parent material: Alluvium

Typical profile

H1 - 0 to 13 inches: ashy fine sandy loam

H2 - 13 to 29 inches: loamy fine sand

H3 - 29 to 60 inches: fine sand

Properties and qualities

Slope: 0 to 3 percent

Depth to restrictive feature: More than 80 inches

Natural drainage class: Well drained

Capacity of the most limiting layer to transmit water (Ksat): High
(1.98 to 5.95 in/hr)

Depth to water table: About 48 to 72 inches

Frequency of flooding: Occasional

Frequency of ponding: None

Available water storage in profile: Moderate (about 6.6 inches)

Interpretive groups

Land capability classification (irrigated): 3w

Land capability classification (nonirrigated): 3w

Hydrologic Soil Group: A

Forage suitability group: Droughty Soils (G002XN402WA)

Hydric soil rating: No

Minor Components

Briscot

Percent of map unit: 2 percent

Landform: Depressions

Hydric soil rating: Yes

Data Source Information

Soil Survey Area: Pierce County Area, Washington
Survey Area Data: Version 14, Sep 10, 2018

APPENDIX B

Basin Exhibits

Predeveloped Basin Map	B-1
Post Developed Basin Map	B-2
Downstream Condition Map	B-3
FIRM Panel (#53053C0342E)	B-4

1200 7TH AVE SE TOWNHOMES

A PORTION OF SEC. 03, T19N, R04E
WILLAMETTE MERIDIAN, PIERCE COUNTY, WASHINGTON

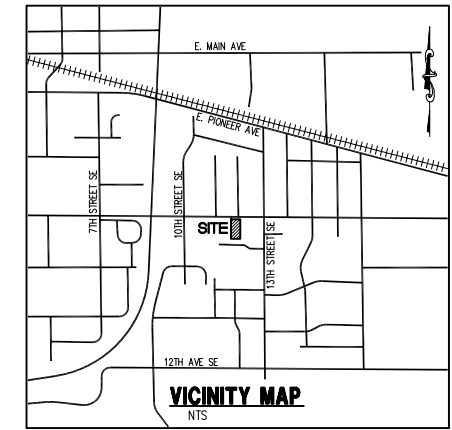

No.	Revision:	Date:

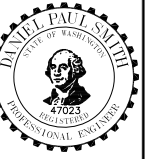

C.E.S. NW INC.
CIVIL ENGINEERING & SURVEYING
429 - 20TH ST. NE, SUITE D
POWELL, WA 98272
PH: (253) 848-4382
cesnw@cesnwinc.com

1200 7TH AVE SE TOWNHOMES
PRE-DEVELOPED BASIN MAP
VITALY KRAVCHISHIN

Project: SETACLLC@GMAIL.COM
Client: VITALY KRAVCHISHIN
Designed: D.P.S.
Drawn: D.P.S.
Checked: D.P.S.
Scale: 1"=20'
Date: 06/13/2024
Job No.: 19078
Sheet No.: **B-1**
1 of 2 Sheets

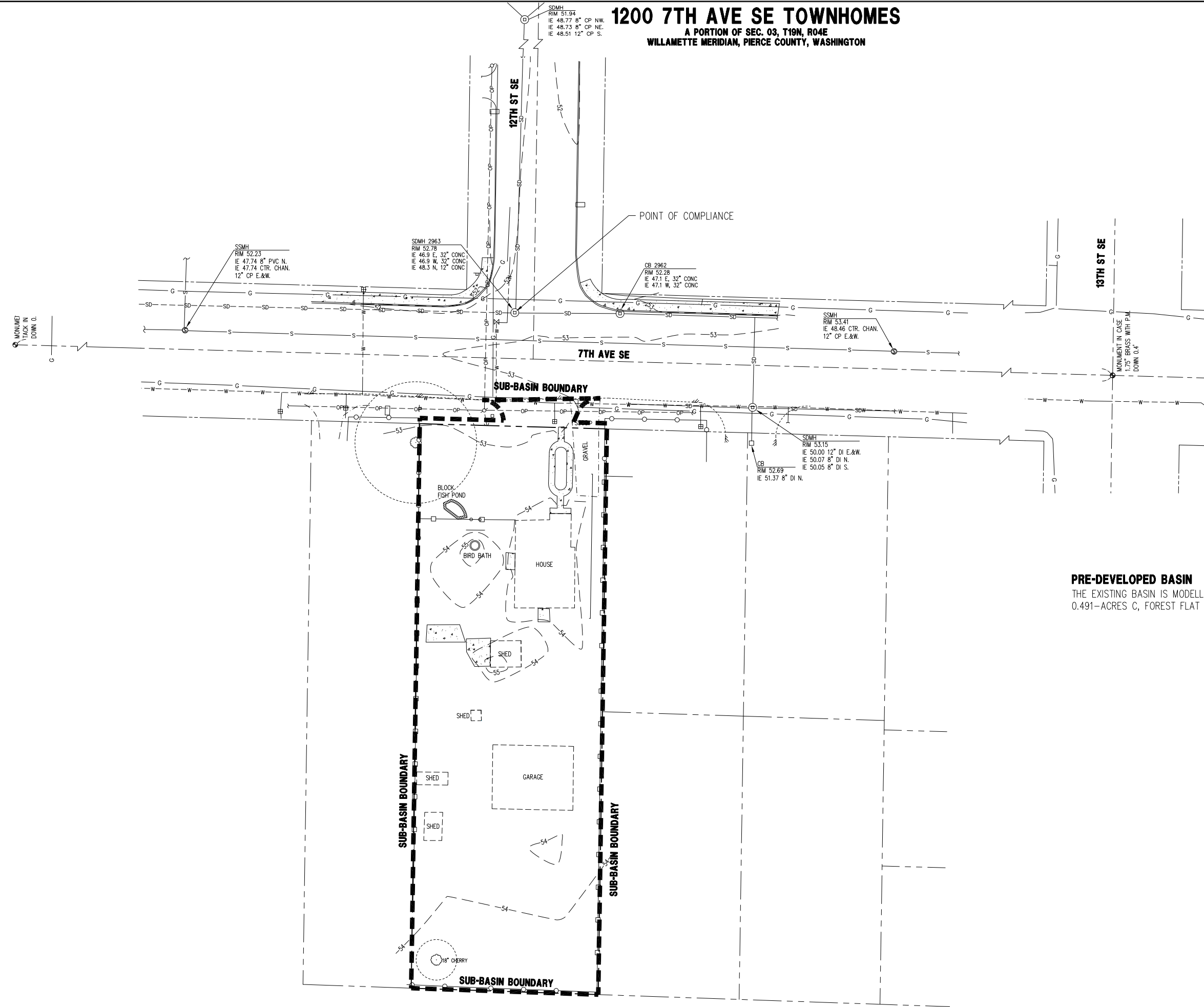

PRE-DEVELOPED BASIN
THE EXISTING BASIN IS MODELLED AS
0.491-ACRES C, FOREST FLAT

1200 7TH AVE SE TOWNHOMES
 A PORTION OF SEC. 03, T19N, R04E
 WILLAMETTE MERIDIAN, PIERCE COUNTY, WASHINGTON

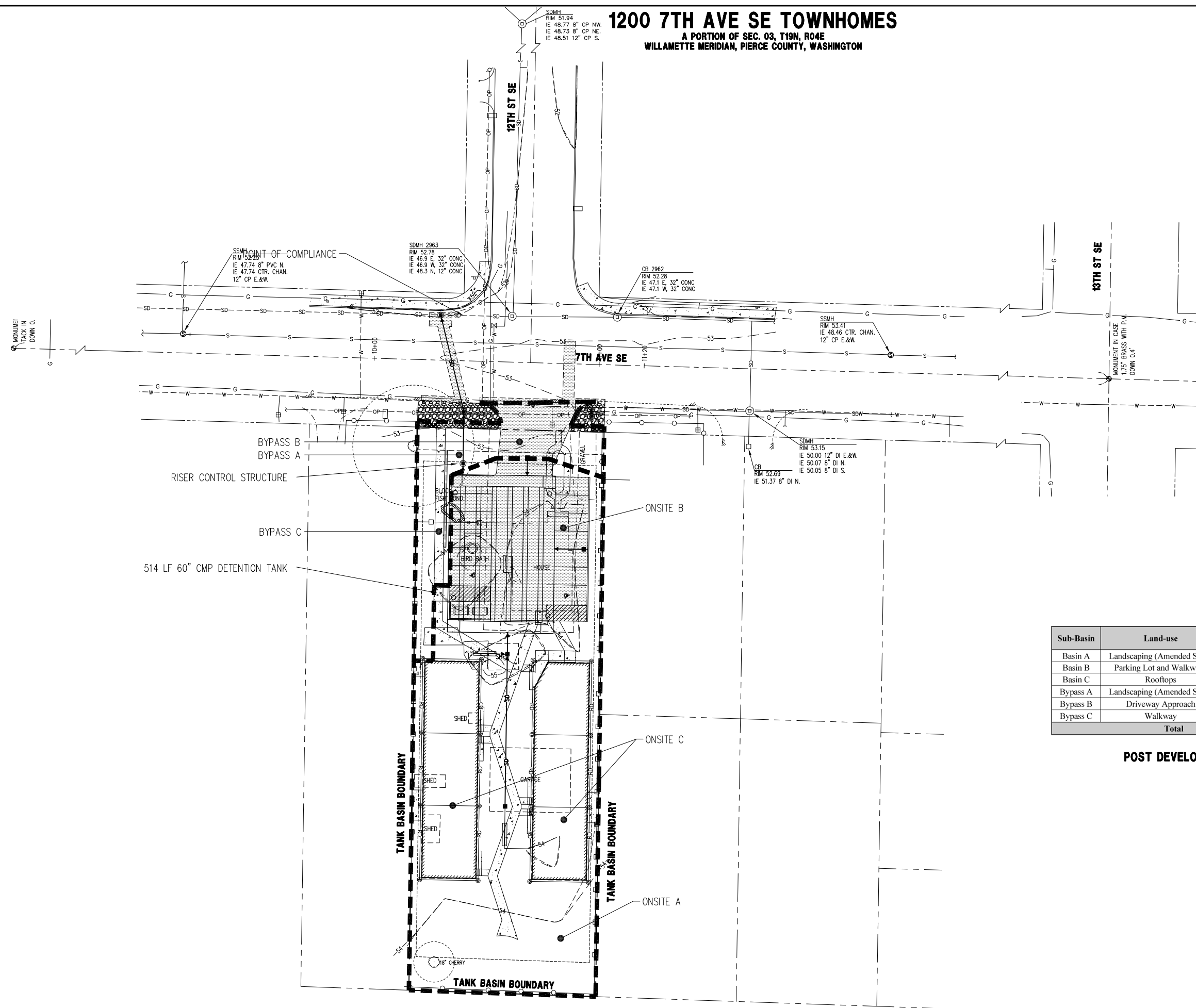
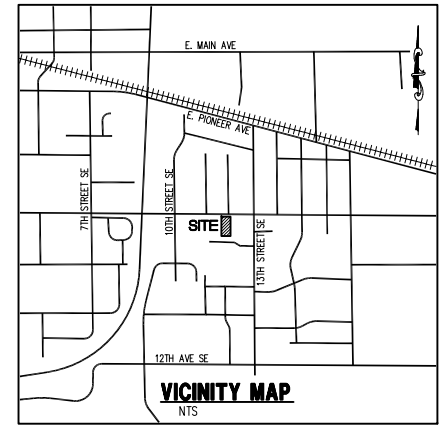

Sub-Basin	Land-use	WWHM Description	Area (acre)
Basin A	Landscaping (Amended Soils)	C, Pasture, Flat.	0.187
Basin B	Parking Lot and Walkways	Parking Lot, Flat	0.128
Basin C	Rooftops	Rooftops Flat	0.108
Bypass A	Landscaping (Amended Soils)	C, Pasture, Mod.	0.044
Bypass B	Driveway Approach	Parking Lot, Mod.	0.018
Bypass C	Walkway	Sidewalk, Flat	0.006
Total			0.491

POST DEVELOPED BASIN

No.	Revision:	Date:



C.E.S. NW INC.
 CIVIL ENGINEERING & SURVEYING
 429 - 29TH ST. NE, SUITE D
 PUYALLUP, WA 98372
 PH: (253) 948-4282
 cesurvey@cesnwinc.com

1200 7TH AVE SE TOWNHOMES
POST DEVELOPED BASIN MAP

Project: SETACLLC@ICLOUD.COM
 Client: VITALY KRAVCHISHIN
 Designed: DPS
 Drawn: DPS
 Checked: DPS
 Scale: 1"=20'
 Date: 06/13/2024
 Job No.: 19078

Downstream Map

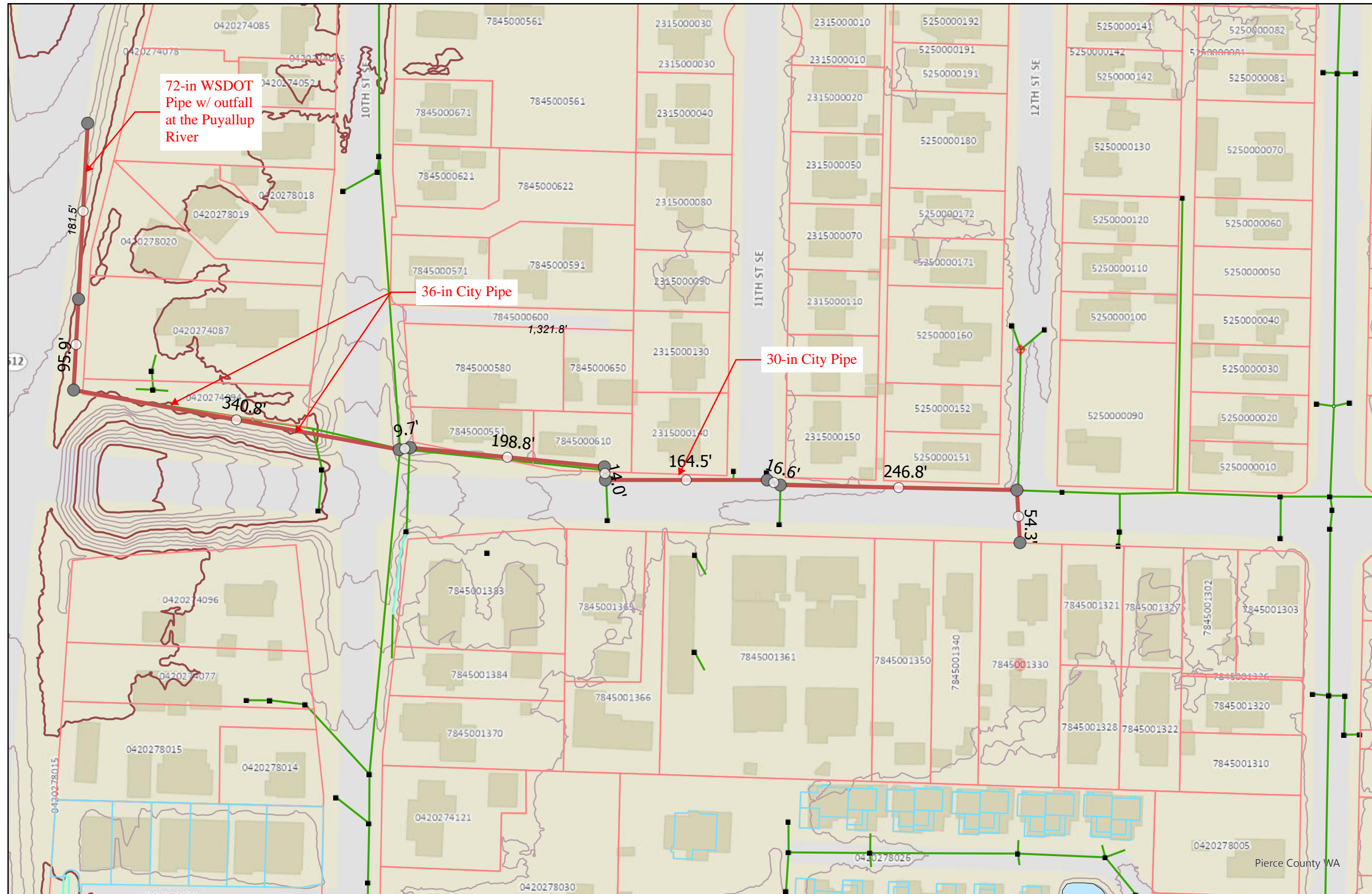

Legend

Tax Parcels

- Base Parcel
- Condominium

Drainage - Puyallup

- Manholes - Puyallup
- Inlets - Puyallup
- Channels - Puyallup
- Pipes - Puyallup
- Stormwater Facilities - Puyallup

Contours - 2017

- 10' Contour Line
- 2' Contour Line

0 20 40 80 Feet

CES • NW
 INCORPORATED
 CIVIL ENGINEERING & SURVEYING
 429 29th St NE, Suite D - Puyallup, WA 98372
 PH: 253.848.4282
 www.cesnwinc.com

The map features are approximate and are intended only to provide an indication of said feature. Additional areas that have not been mapped may be present. This is not a survey. Orthophotos and other data may not align. The County assumes no liability for variations ascertained by actual survey. ALL DATA IS EXPRESSLY PROVIDED 'AS IS' AND 'WITH ALL FAULTS'. The County makes no warranty of fitness for a particular purpose.

National Flood Hazard Layer FIRMette



47°11'20.64"N

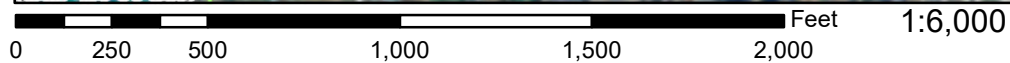
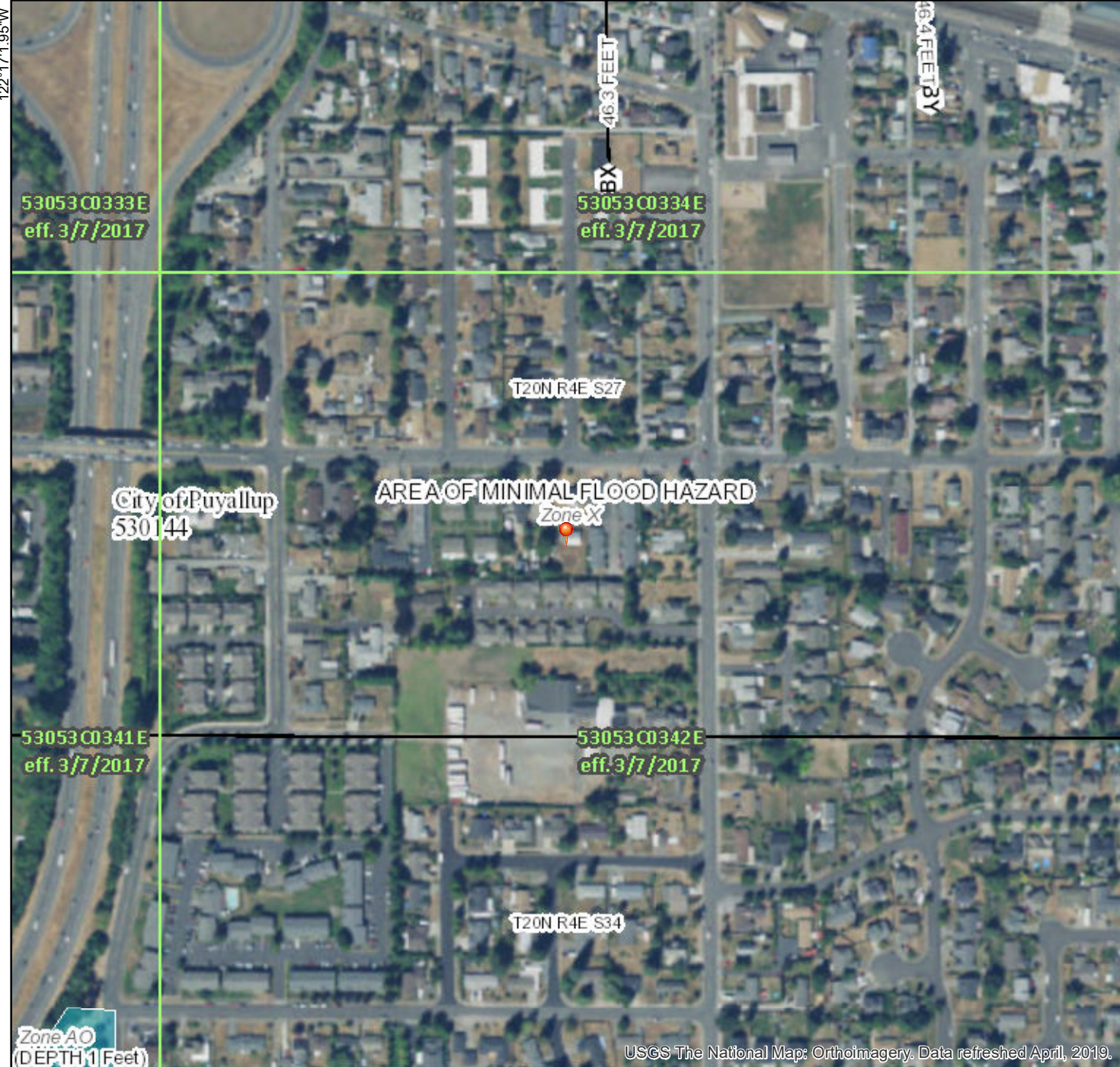

Legend

SEE FIS REPORT FOR DETAILED LEGEND AND INDEX MAP FOR FIRM PANEL LAYOUT

SPECIAL FLOOD HAZARD AREAS		Without Base Flood Elevation (BFE) Zone A, V, A99
		With BFE or Depth Zone AE, AO, AH, VE, AR
		Regulatory Floodway
OTHER AREAS OF FLOOD HAZARD		0.2% Annual Chance Flood Hazard, Areas of 1% annual chance flood with average depth less than one foot or with drainage areas of less than one square mile Zone X
		Future Conditions 1% Annual Chance Flood Hazard Zone X
		Area with Reduced Flood Risk due to Levee. See Notes. Zone X
		Area with Flood Risk due to Levee Zone D
OTHER AREAS		NO SCREEN Area of Minimal Flood Hazard Zone X
		Effective LOMRs
		Area of Undetermined Flood Hazard Zone D
GENERAL STRUCTURES		Channel, Culvert, or Storm Sewer
		Levee, Dike, or Floodwall
OTHER FEATURES		20.2 Cross Sections with 1% Annual Chance Water Surface Elevation
		17.5 Coastal Transect
		Base Flood Elevation Line (BFE)
		Limit of Study
		Jurisdiction Boundary
		Coastal Transect Baseline
MAP PANELS		Digital Data Available
		No Digital Data Available
		Unmapped

The pin displayed on the map is an approximate point selected by the user and does not represent an authoritative property location.

This map complies with FEMA's standards for the use of digital flood maps if it is not void as described below. The basemap shown complies with FEMA's basemap accuracy standards

The flood hazard information is derived directly from the authoritative NFHL web services provided by FEMA. This map was exported on **4/2/2020 at 6:13:10 PM** and does not reflect changes or amendments subsequent to this date and time. The NFHL and effective information may change or become superseded by new data over time.

This map image is void if the one or more of the following map elements do not appear: basemap imagery, flood zone labels, legend, scale bar, map creation date, community identifiers, FIRM panel number, and FIRM effective date. Map images for unmapped and unmodernized areas cannot be used for regulatory purposes.

122°16'24.49"W

47°10'56.19"N

APPENDIX C

Computer Printouts

WWHM Modeling Results

C-1

WWHM2012
PROJECT REPORT

General Model Information

WWHM2012 Project Name: 19078
Site Name: 1200 7th Street
Site Address: 1200 7th Street
City: Puyallup, WA
Report Date: 6/13/2024
Gage: 40 IN EAST
Data Start: 10/01/1901
Data End: 09/30/2059
Timestep: 15 Minute
Precip Scale: 1.000
Version Date: 2023/01/27
Version: 4.2.19

POC Thresholds

Low Flow Threshold for POC1:	50 Percent of the 2 Year
High Flow Threshold for POC1:	50 Year

Landuse Basin Data

Predeveloped Land Use

Basin 1

Bypass:	No
GroundWater:	No
Pervious Land Use C, Forest, Flat	acre 0.491
Pervious Total	0.491
Impervious Land Use	acre
Impervious Total	0
Basin Total	0.491

Mitigated Land Use

Post Dev

Bypass:	No
GroundWater:	No
Pervious Land Use	acre
C, Pasture, Flat	0.187
Pervious Total	0.187
Impervious Land Use	acre
ROOF TOPS FLAT	0.108
PARKING FLAT	0.128
Impervious Total	0.236
Basin Total	0.423

Bypass

Bypass:	Yes
GroundWater:	No
Pervious Land Use C, Pasture, Mod	acre 0.044
Pervious Total	0.044
Impervious Land Use SIDEWALKS FLAT PARKING MOD	acre 0.006 0.018
Impervious Total	0.024
Basin Total	0.068

Routing Elements
Predeveloped Routing

Mitigated Routing

Tank 1

Dimensions
 Depth: 5 ft.
 Tank Type: Circular
 Diameter: 5 ft.
 Length: 514 ft.
 Discharge Structure
 Riser Height: 4 ft.
 Riser Diameter: 18 in.
 Orifice 1 Diameter: 0.250 in. Elevation:0 ft.
 Orifice 2 Diameter: 0.500 in. Elevation:2.87 ft.
 Orifice 3 Diameter: 0.750 in. Elevation:3.66 ft.
 Element Flows To:
 Outlet 1 Outlet 2

Tank Hydraulic Table

Stage(feet)	Area(ac.)	Volume(ac-ft.)	Discharge(cfs)	Infilt(cfs)
0.0000	0.000	0.000	0.000	0.000
0.0556	0.012	0.000	0.000	0.000
0.1111	0.017	0.001	0.000	0.000
0.1667	0.021	0.002	0.000	0.000
0.2222	0.024	0.003	0.000	0.000
0.2778	0.027	0.005	0.000	0.000
0.3333	0.029	0.006	0.001	0.000
0.3889	0.031	0.008	0.001	0.000
0.4444	0.033	0.010	0.001	0.000
0.5000	0.035	0.012	0.001	0.000
0.5556	0.037	0.014	0.001	0.000
0.6111	0.038	0.016	0.001	0.000
0.6667	0.040	0.018	0.001	0.000
0.7222	0.041	0.020	0.001	0.000
0.7778	0.042	0.023	0.001	0.000
0.8333	0.044	0.025	0.001	0.000
0.8889	0.045	0.027	0.001	0.000
0.9444	0.046	0.030	0.001	0.000
1.0000	0.047	0.033	0.001	0.000
1.0556	0.048	0.035	0.001	0.000
1.1111	0.049	0.038	0.001	0.000
1.1667	0.049	0.041	0.001	0.000
1.2222	0.050	0.043	0.001	0.000
1.2778	0.051	0.046	0.001	0.000
1.3333	0.052	0.049	0.002	0.000
1.3889	0.052	0.052	0.002	0.000
1.4444	0.053	0.055	0.002	0.000
1.5000	0.054	0.058	0.002	0.000
1.5556	0.054	0.061	0.002	0.000
1.6111	0.055	0.064	0.002	0.000
1.6667	0.055	0.067	0.002	0.000
1.7222	0.056	0.070	0.002	0.000
1.7778	0.056	0.073	0.002	0.000
1.8333	0.056	0.077	0.002	0.000
1.8889	0.057	0.080	0.002	0.000
1.9444	0.057	0.083	0.002	0.000

2.0000	0.057	0.086	0.002	0.000
2.0556	0.058	0.089	0.002	0.000
2.1111	0.058	0.093	0.002	0.000
2.1667	0.058	0.096	0.002	0.000
2.2222	0.058	0.099	0.002	0.000
2.2778	0.058	0.102	0.002	0.000
2.3333	0.058	0.106	0.002	0.000
2.3889	0.058	0.109	0.002	0.000
2.4444	0.059	0.112	0.002	0.000
2.5000	0.059	0.115	0.002	0.000
2.5556	0.059	0.119	0.002	0.000
2.6111	0.058	0.122	0.002	0.000
2.6667	0.058	0.125	0.002	0.000
2.7222	0.058	0.128	0.002	0.000
2.7778	0.058	0.132	0.002	0.000
2.8333	0.058	0.135	0.002	0.000
2.8889	0.058	0.138	0.003	0.000
2.9444	0.058	0.141	0.004	0.000
3.0000	0.057	0.145	0.005	0.000
3.0556	0.057	0.148	0.005	0.000
3.1111	0.057	0.151	0.006	0.000
3.1667	0.056	0.154	0.006	0.000
3.2222	0.056	0.157	0.007	0.000
3.2778	0.056	0.161	0.007	0.000
3.3333	0.055	0.164	0.007	0.000
3.3889	0.055	0.167	0.008	0.000
3.4444	0.054	0.170	0.008	0.000
3.5000	0.054	0.173	0.008	0.000
3.5556	0.053	0.176	0.008	0.000
3.6111	0.052	0.179	0.009	0.000
3.6667	0.052	0.182	0.010	0.000
3.7222	0.051	0.185	0.013	0.000
3.7778	0.050	0.187	0.015	0.000
3.8333	0.049	0.190	0.016	0.000
3.8889	0.049	0.193	0.017	0.000
3.9444	0.048	0.196	0.018	0.000
4.0000	0.047	0.198	0.019	0.000
4.0556	0.046	0.201	0.228	0.000
4.1111	0.045	0.203	0.609	0.000
4.1667	0.044	0.206	1.096	0.000
4.2222	0.042	0.208	1.659	0.000
4.2778	0.041	0.211	2.272	0.000
4.3333	0.040	0.213	2.906	0.000
4.3889	0.038	0.215	3.534	0.000
4.4444	0.037	0.217	4.129	0.000
4.5000	0.035	0.219	4.665	0.000
4.5556	0.033	0.221	5.124	0.000
4.6111	0.031	0.223	5.495	0.000
4.6667	0.029	0.225	5.782	0.000
4.7222	0.027	0.226	6.003	0.000
4.7778	0.024	0.228	6.279	0.000
4.8333	0.021	0.229	6.499	0.000
4.8889	0.017	0.230	6.711	0.000
4.9444	0.012	0.231	6.917	0.000
5.0000	0.000	0.231	7.118	0.000
5.0556	0.000	0.000	7.312	0.000

Analysis Results

POC 1

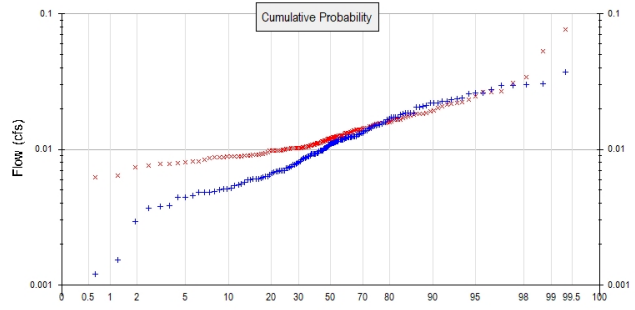
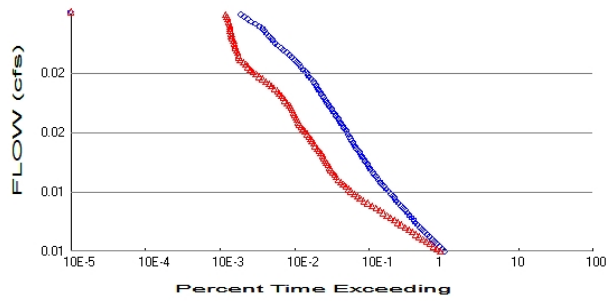

+ Predeveloped x Mitigated

Predeveloped Landuse Totals for POC #1

Total Pervious Area: 0.491
 Total Impervious Area: 0

Mitigated Landuse Totals for POC #1

Total Pervious Area: 0.231
 Total Impervious Area: 0.26

Flow Frequency Method: Log Pearson Type III 17B

Flow Frequency Return Periods for Predeveloped. POC #1

Return Period	Flow(cfs)
2 year	0.011094
5 year	0.017069
10 year	0.020523
25 year	0.024264
50 year	0.02667
100 year	0.028758

Flow Frequency Return Periods for Mitigated. POC #1

Return Period	Flow(cfs)
2 year	0.011955
5 year	0.016723
10 year	0.020602
25 year	0.026419
50 year	0.031488
100 year	0.037252

Annual Peaks

Annual Peaks for Predeveloped and Mitigated. POC #1

Year	Predeveloped	Mitigated
1902	0.009	0.012
1903	0.007	0.013
1904	0.012	0.018
1905	0.006	0.009
1906	0.003	0.009
1907	0.017	0.012
1908	0.012	0.010
1909	0.012	0.010
1910	0.017	0.013
1911	0.011	0.012

1912	0.037	0.026
1913	0.017	0.016
1914	0.004	0.034
1915	0.007	0.009
1916	0.011	0.013
1917	0.004	0.006
1918	0.012	0.013
1919	0.009	0.008
1920	0.011	0.011
1921	0.012	0.010
1922	0.012	0.014
1923	0.010	0.010
1924	0.005	0.014
1925	0.006	0.008
1926	0.011	0.011
1927	0.008	0.010
1928	0.008	0.010
1929	0.017	0.014
1930	0.011	0.015
1931	0.010	0.010
1932	0.008	0.010
1933	0.009	0.010
1934	0.023	0.021
1935	0.010	0.010
1936	0.009	0.011
1937	0.015	0.014
1938	0.009	0.009
1939	0.001	0.009
1940	0.010	0.016
1941	0.006	0.018
1942	0.015	0.016
1943	0.008	0.012
1944	0.016	0.018
1945	0.012	0.012
1946	0.007	0.012
1947	0.005	0.008
1948	0.024	0.012
1949	0.021	0.015
1950	0.006	0.009
1951	0.008	0.016
1952	0.031	0.020
1953	0.028	0.019
1954	0.010	0.010
1955	0.009	0.009
1956	0.005	0.008
1957	0.015	0.009
1958	0.030	0.077
1959	0.018	0.022
1960	0.005	0.009
1961	0.018	0.023
1962	0.010	0.010
1963	0.005	0.008
1964	0.005	0.024
1965	0.021	0.017
1966	0.006	0.009
1967	0.009	0.013
1968	0.010	0.011
1969	0.009	0.010

1970	0.014	0.012
1971	0.022	0.012
1972	0.014	0.031
1973	0.019	0.018
1974	0.010	0.014
1975	0.023	0.022
1976	0.012	0.017
1977	0.006	0.007
1978	0.020	0.018
1979	0.006	0.012
1980	0.012	0.014
1981	0.011	0.012
1982	0.005	0.009
1983	0.018	0.013
1984	0.008	0.012
1985	0.013	0.016
1986	0.011	0.009
1987	0.021	0.014
1988	0.013	0.009
1989	0.012	0.008
1990	0.014	0.011
1991	0.011	0.015
1992	0.014	0.016
1993	0.015	0.012
1994	0.022	0.012
1995	0.005	0.009
1996	0.024	0.022
1997	0.010	0.010
1998	0.012	0.012
1999	0.001	0.013
2000	0.009	0.011
2001	0.005	0.009
2002	0.016	0.017
2003	0.014	0.011
2004	0.012	0.012
2005	0.022	0.027
2006	0.007	0.011
2007	0.007	0.013
2008	0.012	0.011
2009	0.008	0.009
2010	0.007	0.011
2011	0.006	0.010
2012	0.009	0.011
2013	0.007	0.010
2014	0.005	0.010
2015	0.009	0.016
2016	0.004	0.011
2017	0.017	0.015
2018	0.030	0.053
2019	0.030	0.019
2020	0.009	0.013
2021	0.015	0.012
2022	0.006	0.014
2023	0.013	0.018
2024	0.026	0.026
2025	0.011	0.010
2026	0.018	0.015
2027	0.007	0.013

2028	0.006	0.006
2029	0.012	0.010
2030	0.023	0.016
2031	0.008	0.006
2032	0.004	0.009
2033	0.007	0.010
2034	0.007	0.008
2035	0.026	0.017
2036	0.014	0.010
2037	0.004	0.013
2038	0.011	0.012
2039	0.002	0.021
2040	0.007	0.010
2041	0.009	0.011
2042	0.026	0.014
2043	0.013	0.013
2044	0.017	0.014
2045	0.011	0.010
2046	0.013	0.014
2047	0.010	0.010
2048	0.013	0.009
2049	0.011	0.012
2050	0.008	0.010
2051	0.012	0.015
2052	0.007	0.011
2053	0.012	0.014
2054	0.015	0.019
2055	0.006	0.010
2056	0.005	0.013
2057	0.009	0.008
2058	0.010	0.014
2059	0.018	0.017

Ranked Annual Peaks

Ranked Annual Peaks for Predeveloped and Mitigated. POC #1

Rank	Predeveloped	Mitigated
1	0.0373	0.0766
2	0.0306	0.0533
3	0.0301	0.0343
4	0.0298	0.0309
5	0.0295	0.0270
6	0.0277	0.0265
7	0.0262	0.0264
8	0.0259	0.0245
9	0.0258	0.0232
10	0.0239	0.0223
11	0.0236	0.0218
12	0.0232	0.0217
13	0.0227	0.0214
14	0.0226	0.0207
15	0.0220	0.0203
16	0.0219	0.0193
17	0.0219	0.0190
18	0.0211	0.0186
19	0.0207	0.0183
20	0.0205	0.0183
21	0.0204	0.0183
22	0.0186	0.0181

23	0.0185	0.0177
24	0.0185	0.0175
25	0.0185	0.0173
26	0.0183	0.0170
27	0.0181	0.0166
28	0.0174	0.0166
29	0.0172	0.0165
30	0.0172	0.0165
31	0.0172	0.0161
32	0.0168	0.0160
33	0.0167	0.0159
34	0.0159	0.0156
35	0.0158	0.0156
36	0.0153	0.0156
37	0.0153	0.0156
38	0.0153	0.0154
39	0.0150	0.0153
40	0.0149	0.0152
41	0.0147	0.0151
42	0.0145	0.0148
43	0.0144	0.0147
44	0.0143	0.0145
45	0.0139	0.0145
46	0.0138	0.0144
47	0.0136	0.0144
48	0.0132	0.0142
49	0.0132	0.0140
50	0.0131	0.0139
51	0.0129	0.0139
52	0.0128	0.0139
53	0.0125	0.0139
54	0.0124	0.0138
55	0.0124	0.0137
56	0.0124	0.0136
57	0.0124	0.0133
58	0.0123	0.0133
59	0.0123	0.0132
60	0.0123	0.0132
61	0.0121	0.0131
62	0.0121	0.0131
63	0.0120	0.0131
64	0.0119	0.0129
65	0.0118	0.0127
66	0.0118	0.0126
67	0.0118	0.0126
68	0.0117	0.0126
69	0.0117	0.0126
70	0.0115	0.0125
71	0.0114	0.0125
72	0.0114	0.0125
73	0.0113	0.0124
74	0.0112	0.0124
75	0.0111	0.0123
76	0.0111	0.0123
77	0.0111	0.0121
78	0.0110	0.0121
79	0.0110	0.0120
80	0.0109	0.0119

81	0.0108	0.0119
82	0.0105	0.0119
83	0.0104	0.0118
84	0.0102	0.0117
85	0.0102	0.0116
86	0.0102	0.0116
87	0.0100	0.0115
88	0.0099	0.0115
89	0.0098	0.0115
90	0.0098	0.0113
91	0.0098	0.0112
92	0.0097	0.0111
93	0.0095	0.0111
94	0.0094	0.0111
95	0.0094	0.0110
96	0.0093	0.0110
97	0.0093	0.0109
98	0.0092	0.0108
99	0.0092	0.0107
100	0.0092	0.0107
101	0.0090	0.0107
102	0.0088	0.0105
103	0.0088	0.0105
104	0.0087	0.0105
105	0.0086	0.0104
106	0.0086	0.0104
107	0.0085	0.0104
108	0.0084	0.0103
109	0.0082	0.0103
110	0.0080	0.0103
111	0.0079	0.0103
112	0.0078	0.0102
113	0.0077	0.0102
114	0.0077	0.0102
115	0.0075	0.0102
116	0.0074	0.0101
117	0.0073	0.0100
118	0.0073	0.0100
119	0.0070	0.0100
120	0.0070	0.0099
121	0.0070	0.0099
122	0.0069	0.0098
123	0.0068	0.0098
124	0.0068	0.0098
125	0.0068	0.0098
126	0.0067	0.0098
127	0.0065	0.0097
128	0.0063	0.0096
129	0.0063	0.0094
130	0.0062	0.0093
131	0.0062	0.0092
132	0.0061	0.0092
133	0.0061	0.0091
134	0.0060	0.0091
135	0.0060	0.0090
136	0.0060	0.0090
137	0.0057	0.0090
138	0.0055	0.0089

139	0.0055	0.0089
140	0.0054	0.0089
141	0.0052	0.0088
142	0.0051	0.0088
143	0.0051	0.0088
144	0.0050	0.0088
145	0.0049	0.0087
146	0.0048	0.0086
147	0.0048	0.0083
148	0.0048	0.0082
149	0.0045	0.0082
150	0.0044	0.0080
151	0.0044	0.0079
152	0.0039	0.0078
153	0.0038	0.0078
154	0.0037	0.0076
155	0.0030	0.0074
156	0.0015	0.0064
157	0.0012	0.0062
158	0.0008	0.0059

Duration Flows

The Facility PASSED

Flow(cfs)	Predev	Mit	Percentage	Pass/Fail
0.0055	56841	49456	87	Pass
0.0058	52415	44426	84	Pass
0.0060	48365	39844	82	Pass
0.0062	44609	35672	79	Pass
0.0064	41213	32127	77	Pass
0.0066	38238	28875	75	Pass
0.0068	35473	25955	73	Pass
0.0070	32958	23329	70	Pass
0.0073	30526	20941	68	Pass
0.0075	28432	18753	65	Pass
0.0077	26493	16803	63	Pass
0.0079	24742	14942	60	Pass
0.0081	23130	13329	57	Pass
0.0083	21678	11961	55	Pass
0.0085	20315	10648	52	Pass
0.0087	19063	9557	50	Pass
0.0090	17856	8526	47	Pass
0.0092	16714	7640	45	Pass
0.0094	15606	6787	43	Pass
0.0096	14620	5994	40	Pass
0.0098	13717	5283	38	Pass
0.0100	12903	4670	36	Pass
0.0102	12099	4170	34	Pass
0.0105	11401	3824	33	Pass
0.0107	10681	3473	32	Pass
0.0109	9989	3147	31	Pass
0.0111	9368	2895	30	Pass
0.0113	8770	2678	30	Pass
0.0115	8199	2464	30	Pass
0.0117	7734	2278	29	Pass
0.0119	7257	2117	29	Pass
0.0122	6792	1999	29	Pass
0.0124	6426	1895	29	Pass
0.0126	6122	1781	29	Pass
0.0128	5828	1694	29	Pass
0.0130	5557	1621	29	Pass
0.0132	5277	1538	29	Pass
0.0134	5005	1474	29	Pass
0.0137	4790	1409	29	Pass
0.0139	4538	1361	29	Pass
0.0141	4339	1292	29	Pass
0.0143	4159	1235	29	Pass
0.0145	3944	1168	29	Pass
0.0147	3713	1102	29	Pass
0.0149	3537	1044	29	Pass
0.0151	3369	996	29	Pass
0.0154	3227	945	29	Pass
0.0156	3090	904	29	Pass
0.0158	2970	856	28	Pass
0.0160	2851	809	28	Pass
0.0162	2740	754	27	Pass
0.0164	2610	716	27	Pass
0.0166	2477	670	27	Pass

0.0169	2359	638	27	Pass
0.0171	2267	616	27	Pass
0.0173	2159	592	27	Pass
0.0175	2058	571	27	Pass
0.0177	1950	550	28	Pass
0.0179	1837	531	28	Pass
0.0181	1749	510	29	Pass
0.0183	1661	493	29	Pass
0.0186	1578	469	29	Pass
0.0188	1510	435	28	Pass
0.0190	1447	409	28	Pass
0.0192	1367	387	28	Pass
0.0194	1297	365	28	Pass
0.0196	1243	343	27	Pass
0.0198	1182	325	27	Pass
0.0201	1131	294	25	Pass
0.0203	1083	269	24	Pass
0.0205	1026	249	24	Pass
0.0207	980	225	22	Pass
0.0209	925	206	22	Pass
0.0211	871	186	21	Pass
0.0213	819	168	20	Pass
0.0215	772	153	19	Pass
0.0218	717	141	19	Pass
0.0220	668	132	19	Pass
0.0222	629	123	19	Pass
0.0224	588	113	19	Pass
0.0226	549	102	18	Pass
0.0228	508	99	19	Pass
0.0230	473	97	20	Pass
0.0233	428	95	22	Pass
0.0235	393	92	23	Pass
0.0237	363	88	24	Pass
0.0239	330	88	26	Pass
0.0241	300	86	28	Pass
0.0243	281	84	29	Pass
0.0245	264	79	29	Pass
0.0247	248	78	31	Pass
0.0250	233	78	33	Pass
0.0252	219	76	34	Pass
0.0254	205	75	36	Pass
0.0256	186	75	40	Pass
0.0258	163	74	45	Pass
0.0260	144	72	50	Pass
0.0262	129	70	54	Pass
0.0265	117	68	58	Pass
0.0267	105	65	61	Pass

Water Quality

Water Quality BMP Flow and Volume for POC #1

On-line facility volume: 0 acre-feet

On-line facility target flow: 0 cfs.

Adjusted for 15 min: 0 cfs.

Off-line facility target flow: 0 cfs.

Adjusted for 15 min: 0 cfs.

LID Report

LID Technique	Used for Treatment ?	Total Volume Needs Treatment (ac-ft)	Volume Through Facility (ac-ft)	Infiltration Volume (ac-ft)	Cumulative Volume Infiltration Credit	Percent Volume Infiltrated	Water Quality	Percent Water Quality Treated	Comment
Tank 1 POC	<input type="checkbox"/>	111.41			<input type="checkbox"/>	0.00			
Total Volume Infiltrated		111.41	0.00	0.00		0.00	0.00	0%	No Treat. Credit
Compliance with LID Standard 8% of 2-yr to 50% of 2-yr									Duration Analysis Result = Failed

Model Default Modifications

Total of 0 changes have been made.

PERLND Changes

No PERLND changes have been made.

IMPLND Changes

No IMPLND changes have been made.

Appendix
Predeveloped Schematic



Basin 1
0.49ac

Mitigated Schematic

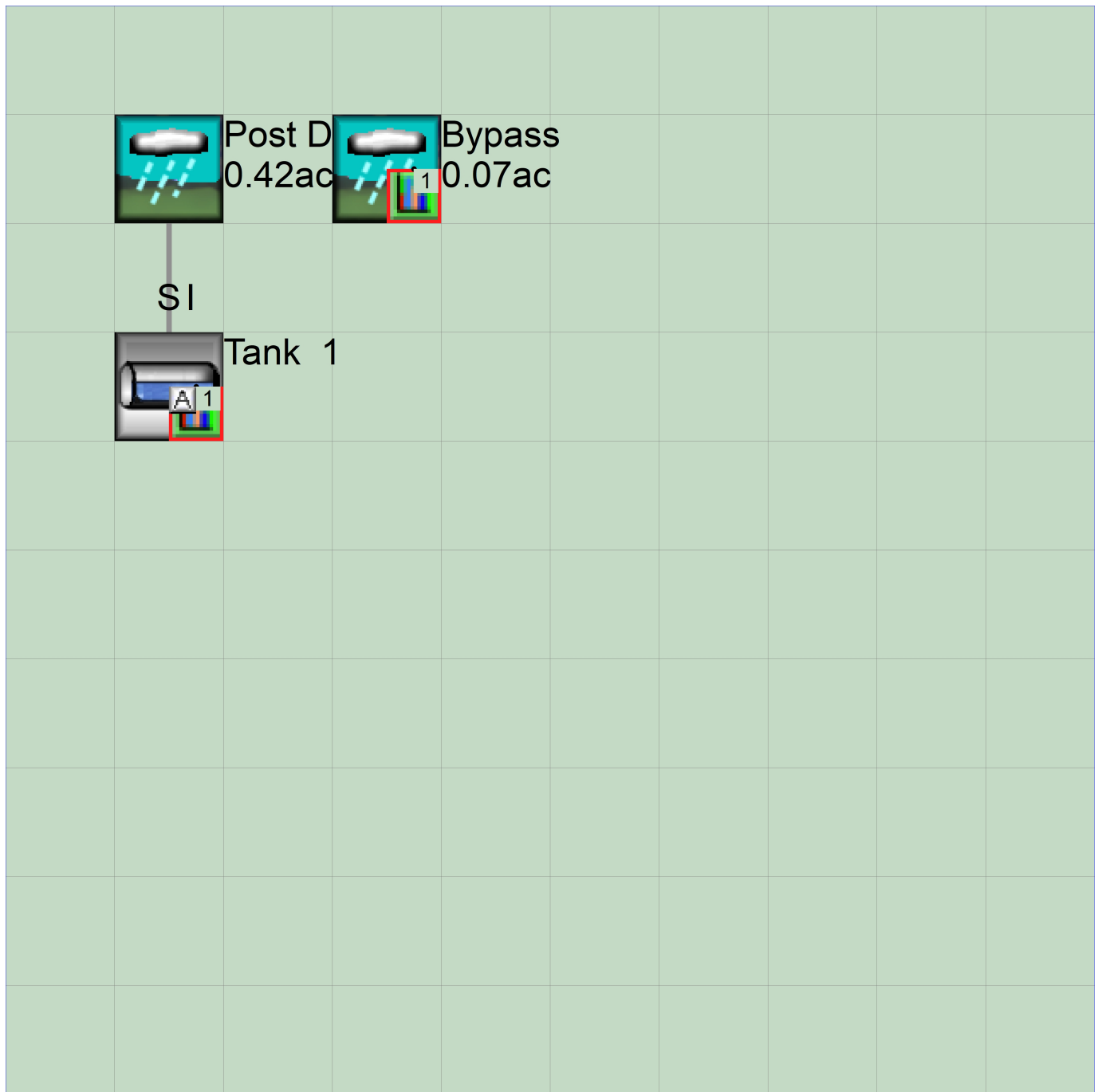

Predeveloped UCI File

RUN

GLOBAL

```
WVHM4 model simulation
START      1901 10 01      END      2059 09 30
RUN INTERP OUTPUT LEVEL   3      0
RESUME     0 RUN          1
UNIT SYSTEM 1
```

END GLOBAL

FILES

```
<File> <Un#> <-----File Name----->***
<-ID->                                     ***
WDM      26      19078.wdm
MESSU    25      Pre19078.MES
          27      Pre19078.L61
          28      Pre19078.L62
          30      POC190781.dat
```

END FILES

OPN SEQUENCE

```
INGRP              INDELT 00:15
  PERLND           10
  COPY             501
  DISPLY           1
```

END INGRP

END OPN SEQUENCE

DISPLY

DISPLY-INFO1

```
# - #<-----Title----->***TRAN PIVL DIG1 FIL1  PYR DIG2 FIL2 YRND
1      Basin 1              MAX              1      2      30      9
```

END DISPLY-INFO1

END DISPLY

COPY

TIMESERIES

```
# - # NPT NMN ***
1      1      1
501    1      1
```

END TIMESERIES

END COPY

GENER

OPCODE

```
#      # OPCD ***
```

END OPCODE

PARM

```
#      #          K ***
```

END PARM

END GENER

PERLND

GEN-INFO

```
<PLS ><-----Name----->NBLKS  Unit-systems  Printer ***
# - #              User  t-series  Engl Metr ***
              in  out          ***
```

```
10      C, Forest, Flat      1      1      1      1      27      0
```

END GEN-INFO

*** Section PWATER***

ACTIVITY

```
<PLS > ***** Active Sections *****
# - # ATMP SNOW PWAT  SED  PST  PWG  PQAL MSTL PEST NITR PHOS TRAC ***
10      0      0      1      0      0      0      0      0      0      0      0      0
```

END ACTIVITY

PRINT-INFO

```
<PLS > ***** Print-flags ***** PIVL  PYR
# - # ATMP SNOW PWAT  SED  PST  PWG  PQAL MSTL PEST NITR PHOS TRAC *****
10      0      0      4      0      0      0      0      0      0      0      0      0      1      9
```

END PRINT-INFO

```

PWAT-PARM1
<PLS > PWATER variable monthly parameter value flags ***
# - # CSNO RTOP UZFG VCS VUZ VNN VIFW VIRC VLE INFC HWT ***
10 0 0 0 0 0 0 0 0 0 0 0
END PWAT-PARM1

PWAT-PARM2
<PLS > PWATER input info: Part 2 ***
# - # ***FOREST LZSN INFILT LRSUR SLSUR KVARY AGWRC
10 0 4.5 0.08 400 0.05 0.5 0.996
END PWAT-PARM2

PWAT-PARM3
<PLS > PWATER input info: Part 3 ***
# - # ***PETMAX PETMIN INFEXP INFILD DEEPFR BASETP AGWETP
10 0 0 2 2 0 0 0
END PWAT-PARM3

PWAT-PARM4
<PLS > PWATER input info: Part 4 ***
# - # CEPSC UZSN NSUR INTFW IRC LZETP ***
10 0.2 0.5 0.35 6 0.5 0.7
END PWAT-PARM4

PWAT-STATE1
<PLS > *** Initial conditions at start of simulation
ran from 1990 to end of 1992 (pat 1-11-95) RUN 21 ***
# - # *** CEPS SURS UZS IFWS LZS AGWS GWVS
10 0 0 0 0 2.5 1 0
END PWAT-STATE1

END PERLND

IMPLND
GEN-INFO
<PLS ><-----Name-----> Unit-systems Printer ***
# - # User t-series Engl Metr ***
in out ***
END GEN-INFO
*** Section IWATER***

ACTIVITY
<PLS > ***** Active Sections *****
# - # ATMP SNOW IWAT SLD IWG IQAL ***
END ACTIVITY

PRINT-INFO
<ILS > ***** Print-flags ***** PIVL PYR
# - # ATMP SNOW IWAT SLD IWG IQAL *****
END PRINT-INFO

IWAT-PARM1
<PLS > IWATER variable monthly parameter value flags ***
# - # CSNO RTOP VRS VNN RTLI ***
END IWAT-PARM1

IWAT-PARM2
<PLS > IWATER input info: Part 2 ***
# - # *** LRSUR SLSUR NSUR RETSC
END IWAT-PARM2

IWAT-PARM3
<PLS > IWATER input info: Part 3 ***
# - # ***PETMAX PETMIN
END IWAT-PARM3

IWAT-STATE1
<PLS > *** Initial conditions at start of simulation
# - # *** RETS SURS
END IWAT-STATE1

```

END IMPLND

SCHEMATIC

<-Source->	<Name> #	<--Area-->	<-factor-->	<-Target->	<Name> #	MBLK	Tbl#	***
Basin	1***							
PERLND	10	0.491		COPY	501	12		
PERLND	10	0.491		COPY	501	13		

*****Routing*****
END SCHEMATIC

NETWORK

<-Volume->	<-Grp>	<-Member->	<--Mult-->	Tran	<-Target vols>	<-Grp>	<-Member->	***	
<Name> #		<Name> #	#	<-factor-->strg	<Name> #	#	<Name> #	***	
COPY	501	OUTPUT	MEAN	1 1	48.4	DISPLY	1	INPUT	TIMSER 1

<-Volume->	<-Grp>	<-Member->	<--Mult-->	Tran	<-Target vols>	<-Grp>	<-Member->	***
<Name> #		<Name> #	#	<-factor-->strg	<Name> #	#	<Name> #	***

END NETWORK

RCHRES

GEN-INFO

RCHRES	Name	Nexits	Unit	Systems	Printer	***
# - #	<----->	<---->	User	T-series	Engl Metr	LKFG
			in	out		

END GEN-INFO
*** Section RCHRES***

ACTIVITY

<PLS > ***** Active Sections *****

# - #	HYFG	ADFG	CNFG	HTFG	SDFG	GQFG	OXFG	NUFG	PKFG	PHFG	***

END ACTIVITY

PRINT-INFO

<PLS > ***** Print-flags ***** PIVL PYR

# - #	HYDR	ADCA	CONS	HEAT	SED	GQL	OXRX	NUTR	PLNK	PHCB	PIVL	PYR	*****

END PRINT-INFO

HYDR-PARM1

RCHRES	Flags	for each HYDR	Section	***	ODGTFG	for each	FUNCT	for each
# - #	VC	A1	A2	A3	ODFVFG	for each	***	possible
	FG	FG	FG	FG	possible	exit	***	possible
	*	*	*	*	*	*	*	possible
	*	*	*	*	*	*	*	exit

END HYDR-PARM1

HYDR-PARM2

# - #	FTABNO	LEN	DELTH	STCOR	KS	DB50	***
<----->	<----->	<----->	<----->	<----->	<----->	<----->	***

END HYDR-PARM2

HYDR-INIT

RCHRES	Initial	conditions	for each HYDR	section	***
# - #	***	VOL	Initial	value of COLIND	Initial
	***	ac-ft	for each	possible	exit
			for each	possible	exit

END HYDR-INIT

END RCHRES

SPEC-ACTIONS

END SPEC-ACTIONS

FTABLES

END FTABLES

EXT SOURCES

<-Volume->	<Member>	SsysSgap	<--Mult-->	Tran	<-Target vols>	<-Grp>	<-Member->	***
<Name> #	<Name> #	tem	strg	<-factor-->strg	<Name> #	#	<Name> #	***
WDM	2	PREC	ENGL	1	PERLND	1 999	EXTNL	PREC
WDM	2	PREC	ENGL	1	IMPLND	1 999	EXTNL	PREC

```
WDM      1 EVAP      ENGL      1          PERLND    1 999 EXTNL  PETINP
WDM      1 EVAP      ENGL      1          IMPLND    1 999 EXTNL  PETINP
```

END EXT SOURCES

EXT TARGETS

```
<-Volume-> <-Grp> <-Member-><--Mult-->Tran <-Volume-> <Member> Tsys Tgap Amd ***
<Name>      #      <Name> # #<-factor->strg <Name>      # <Name>      tem strg strg***
COPY      501 OUTPUT MEAN    1 1      48.4      WDM      501 FLOW      ENGL      REPL
END EXT TARGETS
```

MASS-LINK

```
<Volume>   <-Grp> <-Member-><--Mult-->      <Target>      <-Grp> <-Member->***
<Name>     #      <Name> # #<-factor->      <Name>      <Name> # #***
  MASS-LINK      12
PERLND      PWATER SURO          0.083333      COPY      INPUT  MEAN
  END MASS-LINK      12
```

```
  MASS-LINK      13
PERLND      PWATER IFWO          0.083333      COPY      INPUT  MEAN
  END MASS-LINK      13
```

END MASS-LINK

END RUN

Mitigated UCI File

RUN

GLOBAL

WVHM4 model simulation
START 1901 10 01 END 2059 09 30
RUN INTERP OUTPUT LEVEL 3 0
RESUME 0 RUN 1 UNIT SYSTEM 1
END GLOBAL

FILES

<File>	<Un#>	<-----File Name----->	***
<-ID->			***
WDM	26	19078.wdm	
MESSU	25	Mit19078.MES	
	27	Mit19078.L61	
	28	Mit19078.L62	
	30	POC190781.dat	

END FILES

OPN SEQUENCE

INGRP INDELT 00:15
PERLND 13
IMPLND 4
IMPLND 11
PERLND 14
IMPLND 8
IMPLND 12
RCHRES 1
COPY 1
COPY 501
COPY 601
DISPLY 1

END INGRP

END OPN SEQUENCE

DISPLY

DISPLY-INF01

#	-	#	<-----Title----->	***	TRAN	PIVL	DIG1	FIL1	PYR	DIG2	FIL2	YRND
1			Tank 1		MAX				1	2	30	9

END DISPLY-INF01

END DISPLY

COPY

TIMESERIES

#	-	#	NPT	NMN	***
1			1	1	
501			1	1	
601			1	1	

END TIMESERIES

END COPY

GENER

OPCODE

#	#	OPCD	***

END OPCODE

PARM

#	#	K	***

END PARM

END GENER

PERLND

GEN-INFO

<PLS >	<-----Name----->	NBLKS	Unit-systems	Printer	***	
#	-	#	User	t-series	Engl Metr	***
			in	out		***
13	C, Pasture, Flat	1	1	1	27	0
14	C, Pasture, Mod	1	1	1	27	0

END GEN-INFO

*** Section PWATER***

ACTIVITY

<PLS > ***** Active Sections *****

```

# - # ATMP SNOW PWAT SED PST PWG PQAL MSTL PEST NITR PHOS TRAC ***
13      0      0      1      0      0      0      0      0      0      0      0      0
14      0      0      1      0      0      0      0      0      0      0      0      0
END ACTIVITY

```

PRINT-INFO

```

<PLS > ***** Print-flags ***** PIVL PYR
# - # ATMP SNOW PWAT SED PST PWG PQAL MSTL PEST NITR PHOS TRAC *****
13      0      0      4      0      0      0      0      0      0      0      0      1      9
14      0      0      4      0      0      0      0      0      0      0      0      1      9
END PRINT-INFO

```

PWAT-PARM1

```

<PLS > PWATER variable monthly parameter value flags ***
# - # CSNO RTOP UZFG VCS VUZ VNN VIFW VIRC VLE INFC HWT ***
13      0      0      0      0      0      0      0      0      0      0      0
14      0      0      0      0      0      0      0      0      0      0      0
END PWAT-PARM1

```

PWAT-PARM2

```

<PLS > PWATER input info: Part 2 ***
# - # ***FOREST LZSN INFILT LSUR SLSUR KVARY AGWRC
13      0      4.5      0.06      400      0.05      0.5      0.996
14      0      4.5      0.06      400      0.1      0.5      0.996
END PWAT-PARM2

```

PWAT-PARM3

```

<PLS > PWATER input info: Part 3 ***
# - # ***PETMAX PETMIN INFEXP INFILD DEEPFR BASETP AGWETP
13      0      0      2      2      0      0      0
14      0      0      2      2      0      0      0
END PWAT-PARM3

```

PWAT-PARM4

```

<PLS > PWATER input info: Part 4 ***
# - # CEPSC UZSN NSUR INTFW IRC LZETP ***
13      0.15      0.4      0.3      6      0.5      0.4
14      0.15      0.4      0.3      6      0.5      0.4
END PWAT-PARM4

```

PWAT-STATE1

```

<PLS > *** Initial conditions at start of simulation
ran from 1990 to end of 1992 (pat 1-11-95) RUN 21 ***
# - # *** CEPS SURS UZS IFWS LZS AGWS GWVS
13      0      0      0      0      2.5      1      0
14      0      0      0      0      2.5      1      0
END PWAT-STATE1

```

END PERLND

IMPLND

GEN-INFO

```

<PLS ><-----Name-----> Unit-systems Printer ***
# - # User t-series Engr Metr ***
in out ***
4      ROOF TOPS/FLAT      1      1      1      27      0
11     PARKING/FLAT      1      1      1      27      0
8      SIDEWALKS/FLAT     1      1      1      27      0
12     PARKING/MOD      1      1      1      27      0
END GEN-INFO
*** Section IWATER***

```

ACTIVITY

```

<PLS > ***** Active Sections *****
# - # ATMP SNOW IWAT SLD IWG IQAL ***
4      0      0      1      0      0      0
11     0      0      1      0      0      0
8      0      0      1      0      0      0
12     0      0      1      0      0      0
END ACTIVITY

```

PRINT-INFO

<ILS > ***** Print-flags ***** PIVL PYR										
#	-	#	ATMP	SNOW	IWAT	SLD	IWG	IQAL	*****	
4			0	0	4	0	0	4	1	9
11			0	0	4	0	0	0	1	9
8			0	0	4	0	0	0	1	9
12			0	0	4	0	0	0	1	9

END PRINT-INFO

IWAT-PARM1

<PLS > IWATER variable monthly parameter value flags ***							
#	-	#	CSNO	RTOP	VRS	VNM RTLI	***
4			0	0	0	0	0
11			0	0	0	0	0
8			0	0	0	0	0
12			0	0	0	0	0

END IWAT-PARM1

IWAT-PARM2

<PLS > IWATER input info: Part 2 ***							
#	-	#	***	LSUR	SLSUR	NSUR	RETSC
4				400	0.01	0.1	0.1
11				400	0.01	0.1	0.1
8				400	0.01	0.1	0.1
12				400	0.05	0.1	0.08

END IWAT-PARM2

IWAT-PARM3

<PLS > IWATER input info: Part 3 ***					
#	-	#	***	PETMAX	PETMIN
4				0	0
11				0	0
8				0	0
12				0	0

END IWAT-PARM3

IWAT-STATE1

<PLS > *** Initial conditions at start of simulation					
#	-	#	***	RETS	SURS
4				0	0
11				0	0
8				0	0
12				0	0

END IWAT-STATE1

END IMPLND

SCHEMATIC

<-Source->		<--Area-->	<-Target->	MBLK	***
<Name>	#	<-factor->	<Name>	#	Tbl#
Post Dev	***				
PERLND	13	0.187	RCHRES	1	2
PERLND	13	0.187	RCHRES	1	3
IMPLND	4	0.108	RCHRES	1	5
IMPLND	11	0.128	RCHRES	1	5
Bypass	***				
PERLND	14	0.044	COPY	501	12
PERLND	14	0.044	COPY	601	12
PERLND	14	0.044	COPY	501	13
PERLND	14	0.044	COPY	601	13
IMPLND	8	0.006	COPY	501	15
IMPLND	8	0.006	COPY	601	15
IMPLND	12	0.018	COPY	501	15
IMPLND	12	0.018	COPY	601	15

*****Routing*****

PERLND	13	0.187	COPY	1	12
IMPLND	4	0.108	COPY	1	15
IMPLND	11	0.128	COPY	1	15
PERLND	13	0.187	COPY	1	13

0.333333	0.029434	0.006633	0.000979
0.388889	0.031602	0.008330	0.001058
0.444444	0.033580	0.010141	0.001131
0.500000	0.035399	0.012058	0.001199
0.555556	0.037083	0.014072	0.001264
0.611111	0.038649	0.016176	0.001326
0.666667	0.040112	0.018364	0.001385
0.722222	0.041481	0.020631	0.001441
0.777778	0.042766	0.022972	0.001496
0.833333	0.043975	0.025382	0.001548
0.888889	0.045114	0.027857	0.001599
0.944444	0.046187	0.030393	0.001648
1.000000	0.047199	0.032988	0.001696
1.055556	0.048155	0.035636	0.001743
1.111111	0.049057	0.038337	0.001788
1.166667	0.049908	0.041086	0.001832
1.222222	0.050711	0.043881	0.001875
1.277778	0.051468	0.046720	0.001917
1.333333	0.052181	0.049599	0.001958
1.388889	0.052852	0.052517	0.001999
1.444444	0.053482	0.055471	0.002038
1.500000	0.054074	0.058459	0.002077
1.555556	0.054627	0.061478	0.002115
1.611111	0.055144	0.064528	0.002153
1.666667	0.055625	0.067605	0.002190
1.722222	0.056071	0.070708	0.002226
1.777778	0.056484	0.073834	0.002261
1.833333	0.056863	0.076983	0.002296
1.888889	0.057209	0.080152	0.002331
1.944444	0.057524	0.083339	0.002365
2.000000	0.057807	0.086543	0.002399
2.055556	0.058059	0.089761	0.002432
2.111111	0.058281	0.092993	0.002464
2.166667	0.058472	0.096236	0.002497
2.222222	0.058634	0.099490	0.002528
2.277778	0.058766	0.102751	0.002560
2.333333	0.058868	0.106019	0.002591
2.388889	0.058941	0.109291	0.002621
2.444444	0.058985	0.112567	0.002652
2.500000	0.058999	0.115844	0.002682
2.555556	0.058985	0.119122	0.002711
2.611111	0.058941	0.122398	0.002741
2.666667	0.058868	0.125670	0.002770
2.722222	0.058766	0.128938	0.002798
2.777778	0.058634	0.132199	0.002827
2.833333	0.058472	0.135452	0.002855
2.888889	0.058281	0.138696	0.002881
2.944444	0.058059	0.141927	0.002906
3.000000	0.057807	0.145146	0.002929
3.055556	0.057524	0.148350	0.002950
3.111111	0.057209	0.151537	0.002969
3.166667	0.056863	0.154706	0.002985
3.222222	0.056484	0.157855	0.002999
3.277778	0.056071	0.160981	0.003011
3.333333	0.055625	0.164084	0.003021
3.388889	0.055144	0.167161	0.003028
3.444444	0.054627	0.170210	0.003033
3.500000	0.054074	0.173230	0.003036
3.555556	0.053482	0.176218	0.003037
3.611111	0.052852	0.179172	0.003035
3.666667	0.052181	0.182090	0.003031
3.722222	0.051468	0.184969	0.003025
3.777778	0.050711	0.187807	0.003017
3.833333	0.049908	0.190603	0.003007
3.888889	0.049057	0.193352	0.002995
3.944444	0.048155	0.196052	0.002981
4.000000	0.047199	0.198701	0.002965
4.055556	0.046187	0.201296	0.002947
4.111111	0.045114	0.203832	0.002927
4.166667	0.043975	0.206307	0.002904

```

4.222222 0.042766 0.208717 1.659765
4.277778 0.041481 0.211058 2.272392
4.333333 0.040112 0.213324 2.906782
4.388889 0.038649 0.215513 3.534867
4.444444 0.037083 0.217617 4.129241
4.500000 0.035399 0.219631 4.665341
4.555556 0.033580 0.221548 5.124227
4.611111 0.031602 0.223359 5.495822
4.666667 0.029434 0.225055 5.782567
4.722222 0.027029 0.226625 6.003411
4.777778 0.024317 0.228053 6.279069
4.833333 0.021181 0.229319 6.498982
4.888889 0.017394 0.230395 6.711685
4.944444 0.012369 0.231230 6.917845
5.000000 0.001000 0.231689 7.118031

```

END FTABLE 1

END FTABLES

EXT SOURCES

```

<-Volume-> <Member> SsysSgap<--Mult-->Tran <-Target vols> <-Grp> <-Member-> ***
<Name> # <Name> # tem strg<-factor->strg <Name> # # <Name> # # ***
WDM 2 PREC ENGL 1 PERLND 1 999 EXTNL PREC
WDM 2 PREC ENGL 1 IMPLND 1 999 EXTNL PREC
WDM 1 EVAP ENGL 1 PERLND 1 999 EXTNL PETINP
WDM 1 EVAP ENGL 1 IMPLND 1 999 EXTNL PETINP

```

END EXT SOURCES

EXT TARGETS

```

<-Volume-> <-Grp> <-Member-><--Mult-->Tran <-Volume-> <Member> Tsys Tgap Amd ***
<Name> # <Name> # #<-factor->strg <Name> # <Name> tem strg strg***
RCHRES 1 HYDR RO 1 1 1 WDM 1002 FLOW ENGL REPL
RCHRES 1 HYDR STAGE 1 1 1 WDM 1003 STAG ENGL REPL
COPY 1 OUTPUT MEAN 1 1 48.4 WDM 701 FLOW ENGL REPL
COPY 501 OUTPUT MEAN 1 1 48.4 WDM 801 FLOW ENGL REPL
COPY 601 OUTPUT MEAN 1 1 48.4 WDM 901 FLOW ENGL REPL

```

END EXT TARGETS

MASS-LINK

```

<Volume> <-Grp> <-Member-><--Mult--> <Target> <-Grp> <-Member->***
<Name> <Name> # #<-factor-> <Name> <Name> # #***
MASS-LINK 2
PERLND PWATER SURO 0.083333 RCHRES INFLOW IVOL
END MASS-LINK 2

MASS-LINK 3
PERLND PWATER IFWO 0.083333 RCHRES INFLOW IVOL
END MASS-LINK 3

MASS-LINK 5
IMPLND IWATER SURO 0.083333 RCHRES INFLOW IVOL
END MASS-LINK 5

MASS-LINK 12
PERLND PWATER SURO 0.083333 COPY INPUT MEAN
END MASS-LINK 12

MASS-LINK 13
PERLND PWATER IFWO 0.083333 COPY INPUT MEAN
END MASS-LINK 13

MASS-LINK 15
IMPLND IWATER SURO 0.083333 COPY INPUT MEAN
END MASS-LINK 15

MASS-LINK 16
RCHRES ROFLOW COPY INPUT MEAN
END MASS-LINK 16

```

END MASS-LINK

END RUN

Predeveloped HSPF Message File

Mitigated HSPF Message File

Disclaimer

Legal Notice

This program and accompanying documentation are provided 'as-is' without warranty of any kind. The entire risk regarding the performance and results of this program is assumed by End User. Clear Creek Solutions Inc. and the governmental licensee or sublicensees disclaim all warranties, either expressed or implied, including but not limited to implied warranties of program and accompanying documentation. In no event shall Clear Creek Solutions Inc. be liable for any damages whatsoever (including without limitation to damages for loss of business profits, loss of business information, business interruption, and the like) arising out of the use of, or inability to use this program even if Clear Creek Solutions Inc. or their authorized representatives have been advised of the possibility of such damages. Software Copyright © by : Clear Creek Solutions, Inc. 2005-2024; All Rights Reserved.

Clear Creek Solutions, Inc.
6200 Capitol Blvd. Ste F
Olympia, WA. 98501
Toll Free 1(866)943-0304
Local (360)943-0304

www.clearcreeksolutions.com

Channel Report

<Name>

Circular

Diameter (ft) = 1.00

Invert Elev (ft) = 1.00

Slope (%) = 0.50

N-Value = 0.012

Calculations

Compute by: Known Q

Known Q (cfs) = 0.22

Highlighted

Depth (ft) = 0.20

Q (cfs) = 0.220

Area (sqft) = 0.11

Velocity (ft/s) = 1.95

Wetted Perim (ft) = 0.93

Crit Depth, Y_c (ft) = 0.20

Top Width (ft) = 0.80

EGL (ft) = 0.26

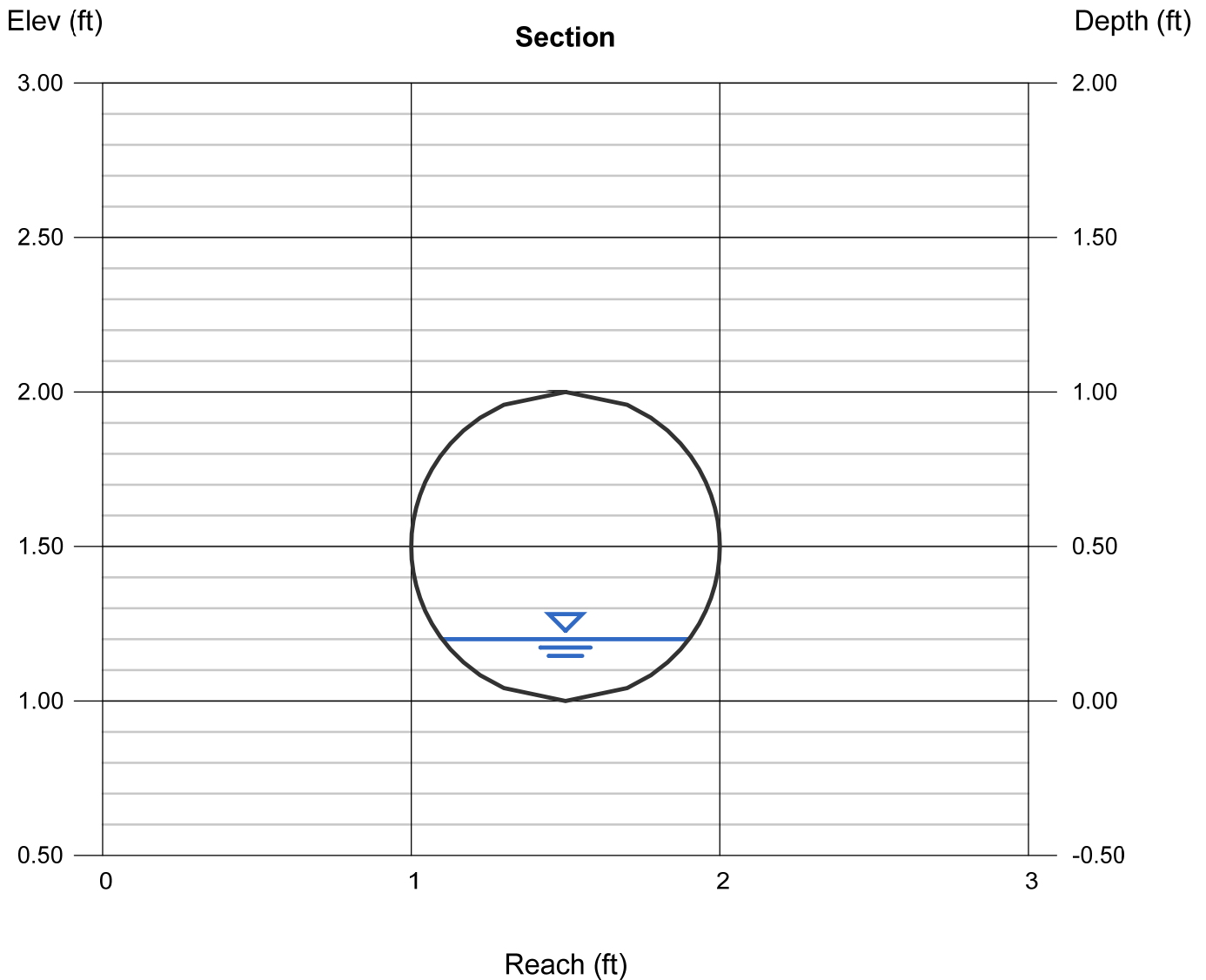

APPENDIX D

Other Studies

Geotechnical Study Report

D-1



April 9, 2020
Updated January 21, 2021
ES-7182

Earth Solutions NW LLC

Geotechnical Engineering, Construction
Observation/Testing and Environmental Services

Tac Build, LLC
729 North Stadium Way
Tacoma, Washington 98403

Attention: Mr. Michael Hopkins

**Subject: Preliminary Geotechnical Evaluation
Proposed Townhomes
1200 – 7th Avenue Southeast
Puyallup, Washington**

Reference: CES NW, Inc.
Preliminary Site Plan, dated June 9, 2020

Puyallup Municipal Code (PMC) Chapter 21.06: Critical Areas

J. Eric Schuster et al.
Geologic Map of the Tacoma 1:100,000-scale Quadrangle, Washington, 2015

Stephen P. Palmer et al.
Liquefaction Susceptibility Map of Pierce County, Washington, 2004

United States Department of Agriculture (USDA)
Natural Resources Conservation Service (NRCS)
Online Web Soil Survey (WSS) resource

Washington State Department of Ecology
2014 Stormwater Management Manual for Western Washington

Dear Mr. Hopkins:

As requested, Earth Solutions NW, LLC (ESNW), has prepared this letter for the proposed project. The letter was prepared in general accordance with the scope of services outlined in the November 2020 change order to our original proposal, which was authorized by you. A summary of the subsurface exploration on site and preliminary geotechnical recommendations to aid with the site design are provided in this letter.

Project Description

We understand that the existing improvements will be razed, and a new townhome development will be constructed. The proposal consists of six townhomes, a parking area (providing access from 7th Avenue Southeast), and an open space area between the proposed townhomes and the southern property line.

The referenced preliminary site plan indicates the parking area is to be comprised of pervious pavement. Based on our discussion with the project civil engineer as a result of our subsurface exploration, we understand that the stormwater management scheme may be modified.

Surface Conditions

The subject site is located south of the intersection between 7th Avenue Southeast and 12th Street Southeast, in Puyallup, Washington. The approximate location of the property is illustrated on Plate 1 (Vicinity Map). The site consists of one tax parcel (Pierce County Parcel No. 7845001330), totaling about 20,000 square feet. The site is surrounded to the east, south, and west by residential structures and to the north by 7th Avenue Southeast.

Subsurface Conditions

An ESNW representative observed, logged, and sampled three test pits on March 5, 2020. Three additional test pits were excavated on December 22, 2020. The test pits were excavated within accessible site areas, using a mini trackhoe and operator retained by ESNW. The test pits were completed to evaluate and classify site soils, characterize groundwater conditions within accessible site areas, and perform in-situ infiltration testing.

The approximate locations of the test pits are depicted on Plate 2 (Test Pit Location Plan). Please refer to the attached test pit logs for a more detailed description of subsurface conditions. Representative soil samples collected at the test pit locations were analyzed in general accordance with both Unified Soil Classification System (USCS) and USDA methods and procedures.

Topsoil and Fill

Where encountered at surface grades, the topsoil was about 6 to 12 inches thick. The topsoil was characterized by the observed dark brown hue, the presence of fine organics, and small root intrusions.

Fill was encountered at test pit locations TP-1, TP-2, TP-5, and TP-6 to depths of about two to four feet below the existing ground surface (bgs). The fill was characterized as sandy silt and poorly graded sand with silt, in a loose to medium dense and moist to wet condition. Small pieces of brick and glass were observed in the fill.

Native Soil

Underlying the topsoil and fill, native soil consisted primarily of poorly graded sand (USCS: SP or SP-SM) with layers of sandy silt (USCS: ML) present. The poorly graded sand layer ranged in thickness between about three feet to more than seven feet. The in-situ density of the native soil was characterized primarily as "medium dense" at each test location, and the in-situ moisture content was characterized as "moist" or "wet" depending on the presence of groundwater. The maximum exploration depth was approximately nine feet bgs.

Geologic Setting

The referenced geologic map resource identifies alluvium (Qa) as the primary native soil unit underlying the subject site and proximate areas. As reported on the geologic map resource, alluvium is typified by well-rounded and moderately to well-sorted beds of fluvial silt, sand, and gravel. The referenced WSS resource identifies Puyallup fine sandy loam (Map Unit Symbol: 31A) as the primary soil unit underlying the subject development area. The Puyallup series was formed in alluvial deposits as a result of the Mount Rainier watershed. Based on our field observations, the on-site native soil is consistent with the local geologic mapping of alluvium.

Groundwater

The groundwater table was encountered at all test pits during our March 2020 and December 2020 explorations at depths of about three and one-half to five-and-one-half feet bgs. Groundwater was allowed to stabilize at TP-4 to a depth of approximately four feet bgs. Shallower groundwater seepage was encountered at depths of roughly two-and-one-half and three feet bgs. It should be noted that seepage rates and elevations fluctuate depending on many factors, including precipitation duration and intensity, the time of year, and soil conditions. In general, groundwater flow rates are higher during the winter, spring, and early summer months.

Geologically Hazardous Areas

We reviewed the referenced PMC chapter to determine the presence of geologically hazardous areas on site. Based on our field observations and our review of the PMC, the subject site lies within a seismic hazard area. The three remaining geologically hazardous areas recognized by the PMC—erosion hazard area, landslide hazard area, and volcanic hazard area—are not applicable to the subject site.

According to PMC 21.06.1210(3)(c), seismic hazard areas are defined as “areas subject to severe risk of damage as a result of earthquake-induced ground shaking, slope failure, settlement or subsidence, soil liquefaction, or tsunamis.” The referenced liquefaction susceptibility map indicates the site and surrounding areas possess high liquefaction susceptibility. Based on our field observations, it is our opinion that the site is correctly mapped within a seismic hazard area, and the site possesses moderate to high susceptibility to liquefaction during a seismic event. Given the level of existing development surrounding the subject site, it is our opinion that the presence of a seismic hazard area does not preclude the proposed townhome development; however, appropriate mitigation measures should be incorporated into the plans, as discussed in this letter.

Preliminary Geotechnical Recommendations

The primary geotechnical considerations for the proposal are associated with structural fill placement and compaction, earthwork and grading activities, foundation support, and stormwater management. Based on our field observations and our understanding of the proposed development, pertinent geotechnical recommendations and design parameters are provided below.

In-situ and Imported Soil

The native alluvium is moisture sensitive, and successful use of the native alluvium as structural fill will largely be dictated by the moisture content at the time of placement and compaction. If the native alluvium cannot be successfully compacted, the use of an imported soil may be necessary.

Performing grading activities during summer months of relatively low rainfall activity is recommended to minimize site degradation. In our opinion, a contingency should be provided in the project budget for the export of soil that cannot be successfully compacted as structural fill, particularly if grading activities take place during periods of extended rainfall activity. In general, soil with an appreciable fines content (greater than 5 percent) typically degrades rapidly when exposed to periods of rainfall.

Imported soil intended for use as structural fill should be evaluated by ESNW during construction. The imported soil must be able to achieve the necessary moisture content, as determined by the Modified Proctor Method (ASTM D1557), at the time of placement and compaction. During wet weather conditions, imported soil intended for use as structural fill should consist of a well-graded, granular soil with a fines content of 5 percent or less (where the fines content is defined as the percent passing the Number 200 sieve, based on the minus three-quarter-inch fraction).

Structural Fill

Structural fill is defined as compacted soil placed in foundation, slab-on-grade, roadway, permanent slope, retaining wall, and utility trench backfill areas. Structural fill placed and compacted during site grading activities should meet the following specifications:

- | | |
|----------------------------------|-------------------------------|
| • Structural fill material | Granular soil* |
| • Moisture content | At or slightly above optimum† |
| • Relative compaction (minimum) | 95 percent (Modified Proctor) |
| • Loose lift thickness (maximum) | 12 inches |

* *The existing soil may not be suitable for use as structural fill unless the soil is at (or slightly above) the optimum moisture content at the time of placement and compaction*

† *Soil shall not be placed dry of optimum and should be evaluated by ESNW during construction*

Foundations

The proposed residential structures may be supported on conventional continuous and spread footing foundations bearing on either compact structural fill or competent native soil. In general, competent native soil should be encountered at a depth of roughly two to three feet bgs. Existing fill intended for reuse as structural fill must be free of debris and should be evaluated by ESNW prior to use. In general, if loose or unsuitable soil conditions are exposed at foundation subgrade elevations, additional mechanical compactive effort or overexcavation and replacement with suitable structural fill will likely be necessary.

Provided foundations will be supported as prescribed, the following parameters may be used for design:

- Allowable soil bearing capacity 2,500 psf
- Passive earth pressure 250 pcf (equivalent fluid)
- Coefficient of friction 0.35

A one-third increase in the allowable soil bearing capacity may be assumed for short-term wind and seismic loading conditions. The above passive pressure and friction values include a factor-of-safety of 1.5. With structural loading as expected, about one inch of total static settlement and about one-half inch of differential static settlement is anticipated. Most of the anticipated settlement should occur during construction when dead loads are applied.

Seismic Design

The 2015 International Building Code recognizes the American Society of Civil Engineers (ASCE) for seismic site class definitions. Based on the soil conditions observed at the test pit locations, in accordance with Table 20.3-1 of the ASCE Minimum Design Loads for Buildings and Other Structures manual, Site Class E should be used for design.

As summarized in the *Geologically Hazardous Areas* section of this letter, site susceptibility to liquefaction is characterized as moderate to high. Based on our experience with alluvial soil, liquefaction-induced settlement of the native soil may be roughly two to four inches and would likely not occur uniformly. ESNW can provide supplementary recommendations for soil improvement if the settlement estimates provided in this section are not tolerable, which may include a surcharge program, using grid foundations supported on at least two feet of structural fill, or pile-supported foundations.

Slab-on-Grade Floors

Slab-on-grade floors for the proposed residential structures should be supported on firm and unyielding subgrades comprised of competent native soil, compacted structural fill, or new structural fill. Unstable or yielding subgrade areas should be recompacted or overexcavated and replaced with suitable structural fill prior to slab construction.

A capillary break, consisting of at least four inches of free-draining crushed rock or gravel, should be placed below each slab. The free-draining material should have a fines content of 5 percent or less (where the fines content is defined as the percent passing the Number 200 sieve, based on the minus three-quarter-inch fraction). In areas where slab moisture is undesirable, installation of a vapor barrier below each slab should be considered. If a vapor barrier is to be utilized, it should be a material specifically designed for use as a vapor barrier and should be installed in accordance with the specifications of the manufacturer.

Retaining Walls

Retaining walls must be designed to resist earth pressures and applicable surcharge loads. The following parameters may be used for design:

- Active earth pressure (unrestrained condition) 40 pcf (equivalent fluid)
- At-rest earth pressure (restrained condition) 60 pcf
- Traffic surcharge* (passenger vehicles) 70 psf (rectangular distribution)
- Passive earth pressure 250 pcf (equivalent fluid)
- Coefficient of friction 0.35
- Seismic surcharge 8H psf†

* Where applicable

† Where H equals the retained height (in feet)

The above design parameters are based on a level backfill condition and level grade at the wall toe under the assumption that native soil will be retained. If a significant zone of imported structural fill will be retained directly behind the wall, less stringent design parameters can be provided. Revised design values will be necessary if sloping grades are to be used above or below retaining walls. Additional surcharge loading from adjacent foundations, sloped backfill, or other relevant loads should be included in the retaining wall design.

Retaining walls should be backfilled with free-draining material that extends along the height of the wall and a distance of at least 18 inches behind the wall. The upper 12 inches of the wall backfill may consist of a less permeable soil if desired. A perforated drainpipe should be placed along the base of the wall and connected to an approved discharge location. A typical retaining wall drainage detail is provided on Plate 3. If drainage is not provided, hydrostatic pressures should be included in the wall design.

Drainage

Groundwater will likely be encountered in site excavations, especially those necessary to construct utility trenches. Temporary measures to control surface water runoff and groundwater during construction would likely involve interceptor trenches and sumps. ESNW should be consulted during preliminary grading to both identify areas of seepage and provide recommendations to reduce the potential for seepage-related instability.

Finish grades must be designed to direct surface drain water away from structures and slopes. Water must not be allowed to pond adjacent to structures. In our opinion, foundation drains should be installed along building perimeter footings. A typical foundation drain detail is provided on Plate 4.

Infiltration Evaluation

The referenced preliminary site plan indicates the parking area will be comprised of pervious pavement. ESNW performed one small-scale Pilot Infiltration Test (PIT) at TP-5 at a depth of approximately three and one-half feet bgs. The PIT was performed outside of the building footprint. During the soaking and test periods, no measurable rate was obtained, i.e., the infiltration rate was 0 inches per hour. After the PIT was deemed complete, the test pit was advanced an additional five and one-half feet. Groundwater seepage was observed directly beneath the test depth and on intermittent silt layers, to the maximum exploration depth of about nine feet bgs.

Based on the results of our testing, ESNW interprets the sandy silt to represent an impermeable layer. Per the guidance provided in BMP T5.15 of the referenced 2014 Manual, endorsed by the City of Puyallup, it is our opinion that the impermeable sandy silt layer would create saturated conditions within one foot of the bottom of the lowest pavement gravel base course. As such, permeable pavement should not be considered feasible from a geotechnical standpoint. In addition, the presence of relatively shallow groundwater would preclude the use of deeper infiltration galleries.

In general, based on our field observations, the subject site is not suitable for infiltration. The presence of both uniform, shallow groundwater conditions and a uniformly present impermeable layer render infiltration impracticable from a geotechnical standpoint.

Limitations

This letter has been prepared for the exclusive use of Tac Build, LLC, and its representatives. No warranty, express or implied, is made. The recommendations and conclusions provided in this letter are professional opinions consistent with the level of care and skill that is typical of other members in the profession currently practicing under similar conditions in this area. Variations in the soil and groundwater conditions encountered at the test pit locations may exist and may not become evident until construction. ESNW should reevaluate the contents of this letter if variations are encountered.

We trust this letter meets your current needs. Please call if you have any questions about this letter or if we can be of further assistance.

Sincerely,

EARTH SOLUTIONS NW, LLC



Samuel E. Suruda, G.I.T.
Staff Geologist



Keven D. Hoffmann, P.E.
Senior Project Manager

Attachments: Plate 1 – Vicinity Map
Plate 2 – Test Pit Location Plan
Plate 3 – Retaining Wall Drainage Detail
Plate 4 – Footing Drain Detail
Test Pit Logs
Grain Size Distribution

cc: CES NW, Inc.
Attention: Mr. Daniel Smith, P.E. (Email only)



Reference:
Pierce County, Washington
OpenStreetMap.org





Earth Solutions NW LLC

Geotechnical Engineering, Construction
Observation/Testing and Environmental Services



Vicinity Map
1200 – 7th Ave Townhomes
Puyallup, Washington

Drwn. MRS	Date 01/19/2021	Proj. No. 7182
Checked SES	Date Jan. 2021	Plate 1

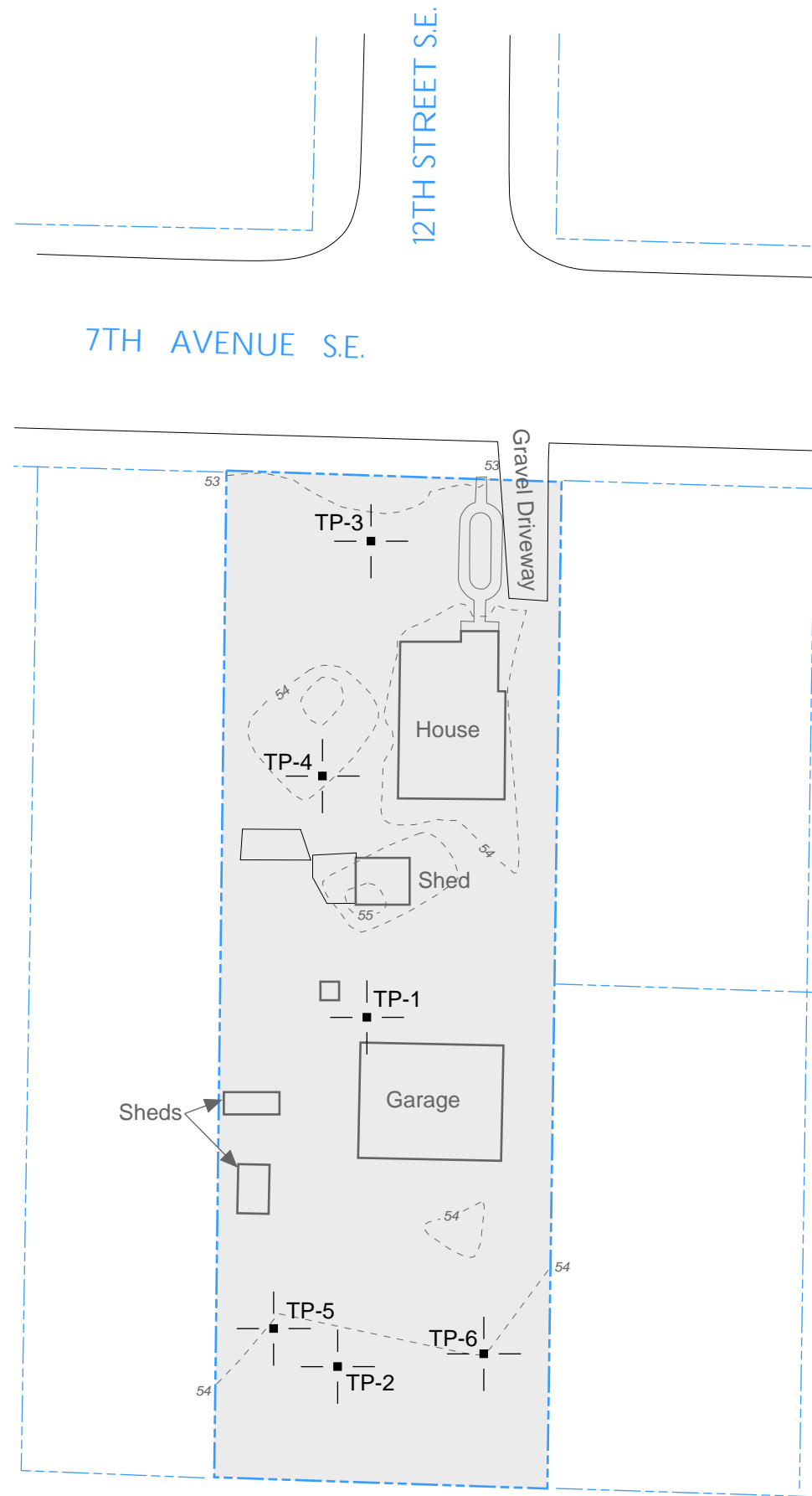
NOTE: This plate may contain areas of color. ESNW cannot be responsible for any subsequent misinterpretation of the information resulting from black & white reproductions of this plate.



LEGEND

- TP-1 | Approximate Location of ESNW Test Pit, Proj. No. ES-7182, Mar./Dec. 2020
-  Subject Site
-  Existing Building

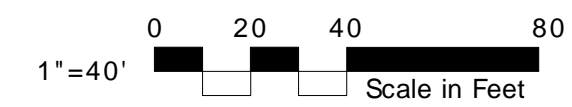
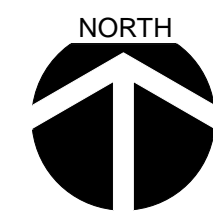

NOTE: The graphics shown on this plate are not intended for design purposes or precise scale measurements, but only to illustrate the approximate test locations relative to the approximate locations of existing and / or proposed site features. The information illustrated is largely based on data provided by the client at the time of our study. ESNW cannot be responsible for subsequent design changes or interpretation of the data by others.

NOTE: This plate may contain areas of color. ESNW cannot be responsible for any subsequent misinterpretation of the information resulting from black & white reproductions of this plate.

Test Pit Location Plan
 1200 – 7th Ave Townhomes
 Puyallup, Washington

Earth Solutions NW LLC
 Geotechnical Engineering, Construction
 Observation/Testing and Environmental Services



Drwn. By MRS
Checked By SES
Date 01/19/2021
Proj. No. 7182
Plate 2

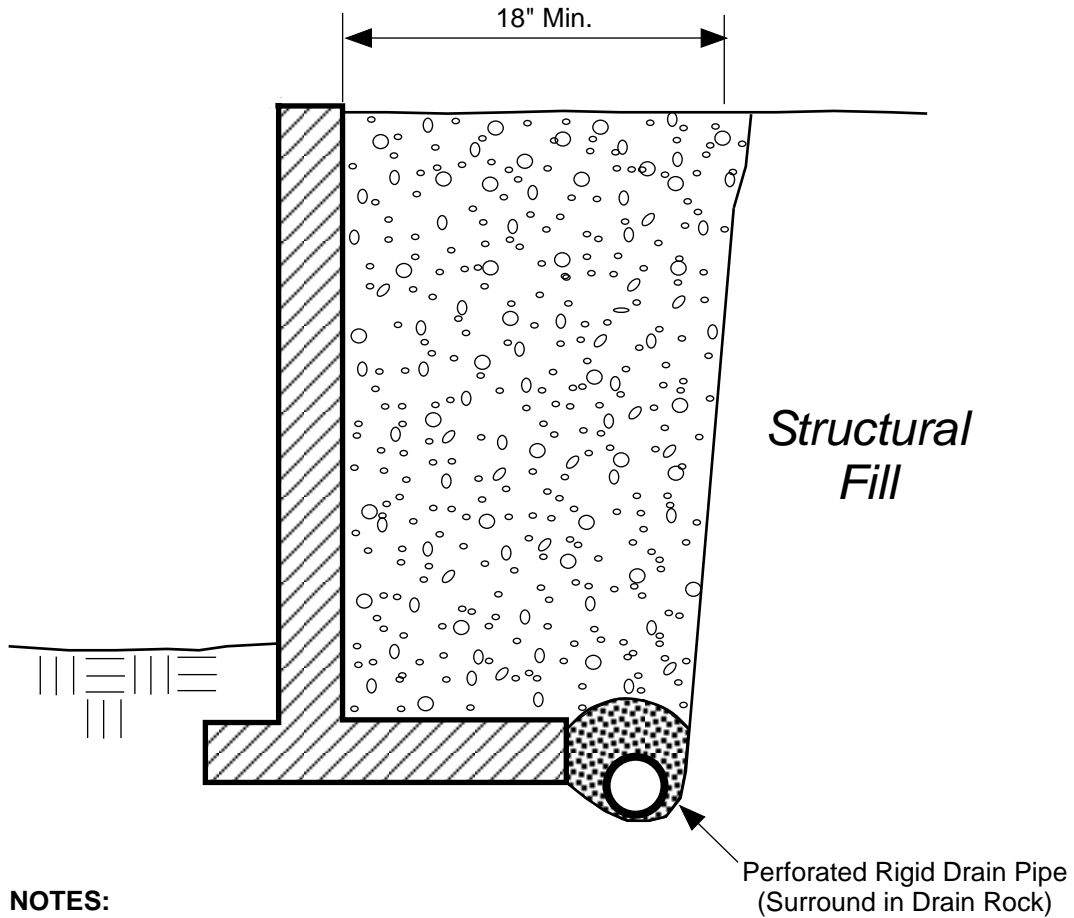

NOTES:

- Free-draining Backfill should consist of soil having less than 5 percent fines. Percent passing No. 4 sieve should be 25 to 75 percent.
- Sheet Drain may be feasible in lieu of Free-draining Backfill, per ESNW recommendations.
- Drain Pipe should consist of perforated, rigid PVC Pipe surrounded with 1-inch Drain Rock.

SCHMATIC ONLY - NOT TO SCALE
NOT A CONSTRUCTION DRAWING

LEGEND:

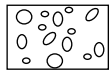

Free-draining Structural Backfill



1-inch Drain Rock

		Earth Solutions NW_{LLC} Geotechnical Engineering Construction Observation/Testing and Environmental Services	
Retaining Wall Drainage Detail 1200 – 7th Ave Townhomes Puyallup, Washington			
Drwn. MRS	Date 01/19/2021	Proj. No. 7182	
Checked SES	Date Jan. 2021	Plate 3	

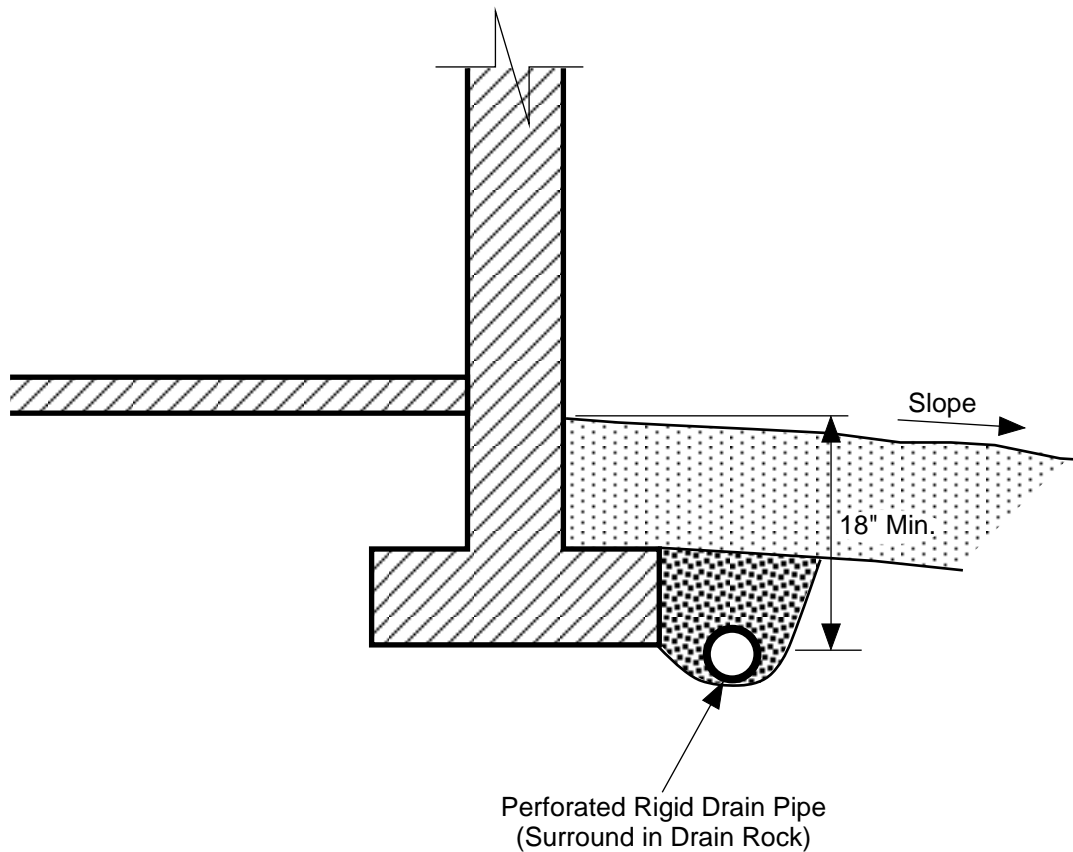

NOTES:

- Do NOT tie roof downspouts to Footing Drain.
- Surface Seal to consist of 12" of less permeable, suitable soil. Slope away from building.

SCHEMATIC ONLY - NOT TO SCALE
NOT A CONSTRUCTION DRAWING

LEGEND:

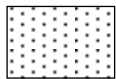

Surface Seal: native soil or other low-permeability material.

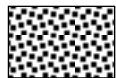

1-inch Drain Rock

	Earth Solutions NW_{LLC} Geotechnical Engineering, Construction Observation/Testing and Environmental Services	
	Footing Drain Detail 1200 – 7th Ave Townhomes Puyallup, Washington	
Drwn. MRS	Date 01/19/2021	Proj. No. 7182
Checked SES	Date Jan. 2021	Plate 4

Earth Solutions NW_{LLC}

SOIL CLASSIFICATION CHART

MAJOR DIVISIONS			SYMBOLS		TYPICAL DESCRIPTIONS	
			GRAPH	LETTER		
COARSE GRAINED SOILS MORE THAN 50% OF MATERIAL IS LARGER THAN NO. 200 SIEVE SIZE	GRAVEL AND GRAVELLY SOILS CLEAN GRAVELS (LITTLE OR NO FINES)	(LITTLE OR NO FINES)		GW	WELL-GRADED GRAVELS, GRAVEL - SAND MIXTURES, LITTLE OR NO FINES	
				GP	POORLY-GRADED GRAVELS, GRAVEL - SAND MIXTURES, LITTLE OR NO FINES	
				GM	SILTY GRAVELS, GRAVEL - SAND - SILT MIXTURES	
	(APPRECIABLE AMOUNT OF FINES)	(APPRECIABLE AMOUNT OF FINES)		GC	CLAYEY GRAVELS, GRAVEL - SAND - CLAY MIXTURES	
			SAND AND SANDY SOILS CLEAN SANDS (LITTLE OR NO FINES)		SW	WELL-GRADED SANDS, GRAVELLY SANDS, LITTLE OR NO FINES
					SP	POORLY-GRADED SANDS, GRAVELLY SAND, LITTLE OR NO FINES
	(APPRECIABLE AMOUNT OF FINES)	(APPRECIABLE AMOUNT OF FINES)		SM	SILTY SANDS, SAND - SILT MIXTURES	
				SC	CLAYEY SANDS, SAND - CLAY MIXTURES	
	FINE GRAINED SOILS MORE THAN 50% OF MATERIAL IS SMALLER THAN NO. 200 SIEVE SIZE	SILTS AND CLAYS LIQUID LIMIT LESS THAN 50	LIQUID LIMIT LESS THAN 50		ML	INORGANIC SILTS AND VERY FINE SANDS, ROCK FLOUR, SILTY OR CLAYEY FINE SANDS OR CLAYEY SILTS WITH SLIGHT PLASTICITY
				CL	INORGANIC CLAYS OF LOW TO MEDIUM PLASTICITY, GRAVELLY CLAYS, SANDY CLAYS, SILTY CLAYS, LEAN CLAYS	
				OL	ORGANIC SILTS AND ORGANIC SILTY CLAYS OF LOW PLASTICITY	
SILTS AND CLAYS LIQUID LIMIT GREATER THAN 50		LIQUID LIMIT GREATER THAN 50		MH	INORGANIC SILTS, MICACEOUS OR DIATOMACEOUS FINE SAND OR SILTY SOILS	
				CH	INORGANIC CLAYS OF HIGH PLASTICITY	
				OH	ORGANIC CLAYS OF MEDIUM TO HIGH PLASTICITY, ORGANIC SILTS	
HIGHLY ORGANIC SOILS				PT	PEAT, HUMUS, SWAMP SOILS WITH HIGH ORGANIC CONTENTS	

DUAL SYMBOLS are used to indicate borderline soil classifications.



The discussion in the text of this report is necessary for a proper understanding of the nature of the material presented in the attached logs.



Earth Solutions NW, LLC
 15365 N.E. 90th Street, Suite 100
 Redmond, Washington 98052
 Telephone: 425-449-4704
 Fax: 425-449-4711

TEST PIT NUMBER TP-1

PROJECT NUMBER ES-7182 PROJECT NAME 1200 – 7th Ave Townhomes
 DATE STARTED 3/5/20 COMPLETED 3/5/20 GROUND ELEVATION 55 ft TEST PIT SIZE _____
 EXCAVATION CONTRACTOR NW Excavating GROUND WATER LEVELS:
 EXCAVATION METHOD _____ ∇ AT TIME OF EXCAVATION 5.5 ft
 LOGGED BY SES CHECKED BY KDH AT END OF EXCAVATION ---
 NOTES Depth of Topsoil & Sod 12": grass AFTER EXCAVATION ---

DEPTH (ft)	SAMPLE TYPE NUMBER	TESTS	U.S.C.S.	GRAPHIC LOG	MATERIAL DESCRIPTION
0					
			TPSL		Dark brown TOPSOIL (Fill) 54.0
		MC = 8.7% Fines = 7.9%	SP-SM		Dark gray poorly graded SAND with silt, loose to medium dense, moist (Fill) -moderate caving to BOH -groundwater seepage [USDA Classification: slightly gravelly SAND] 51.0
5		MC = 32.2%	ML		Dark gray sandy SILT, medium dense, wet ∇ -groundwater table, becomes water bearing 48.0
		MC = 27.7%			

Test pit terminated at 7.0 feet below existing grade due to caving. Groundwater seepage encountered at 3.0 feet and groundwater table encountered at 5.5 feet during excavation. Caving observed from 2.0 feet to BOH.





Earth Solutions NW, LLC
 15365 N.E. 90th Street, Suite 100
 Redmond, Washington 98052
 Telephone: 425-449-4704
 Fax: 425-449-4711

TEST PIT NUMBER TP-2

PAGE 1 OF 1

PROJECT NUMBER ES-7182 PROJECT NAME 1200 – 7th Ave Townhomes
 DATE STARTED 3/5/20 COMPLETED 3/5/20 GROUND ELEVATION 54 ft TEST PIT SIZE _____
 EXCAVATION CONTRACTOR NW Excavating GROUND WATER LEVELS:
 EXCAVATION METHOD _____ ∇ AT TIME OF EXCAVATION 5.5 ft
 LOGGED BY SES CHECKED BY KDH AT END OF EXCAVATION ---
 NOTES Surface Conditions: grass AFTER EXCAVATION ---

DEPTH (ft)	SAMPLE TYPE NUMBER	TESTS	U.S.C.S.	GRAPHIC LOG	MATERIAL DESCRIPTION
0					
		MC = 33.0% Fines = 87.5%	ML		Gray sandy SILT, loose to medium dense, wet (Fill) -mottled texture [USDA Classification: slightly gravelly LOAM] 52.0
		MC = 17.4% Fines = 5.8%	SP-SM		Dark gray poorly graded SAND with silt, medium dense, moist -groundwater seepage -moderate caving to BOH -becomes wet [USDA Classification: gravelly SAND] 48.0 ∇ -groundwater table
5		MC = 71.6% MC = 31.9% Fines = 25.3%	ML		Gray SILT, medium dense, water bearing -wood debris [USDA Classification: slightly gravelly LOAM] 46.0

Test pit terminated at 8.0 feet below existing grade. Groundwater seepage encountered at 3.0 feet and groundwater table encountered at 5.5 feet during excavation. Caving observed from 4.0 feet to BOH



Earth Solutions NW, LLC
 15365 N.E. 90th Street, Suite 100
 Redmond, Washington 98052
 Telephone: 425-449-4704
 Fax: 425-449-4711

TEST PIT NUMBER TP-3

PROJECT NUMBER ES-7182 PROJECT NAME 1200 – 7th Ave Townhomes
 DATE STARTED 3/5/20 COMPLETED 3/5/20 GROUND ELEVATION 53 ft TEST PIT SIZE _____
 EXCAVATION CONTRACTOR NW Excavating GROUND WATER LEVELS:
 EXCAVATION METHOD _____ ∇ AT TIME OF EXCAVATION 5.0 ft
 LOGGED BY SES CHECKED BY KDH AT END OF EXCAVATION ---
 NOTES Surface Conditions: grass AFTER EXCAVATION ---

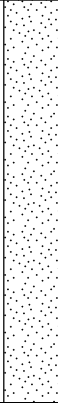
DEPTH (ft)	SAMPLE TYPE NUMBER	TESTS	U.S.C.S.	GRAPHIC LOG	MATERIAL DESCRIPTION
0					
		MC = 26.9% Fines = 56.3%	ML		Brown sandy SILT, medium dense, moist -root intrusions to 1.5' -massive (blocky) bedding, iron oxide staining [USDA Classification: slightly gravelly LOAM] -groundwater seepage at 2.5' 50.5
5		MC = 19.9% Fines = 4.0%	SP		Dark gray poorly graded SAND, medium dense, wet [USDA Classification: slightly gravelly coarse SAND] -moderate caving to BOH ∇ -groundwater table, becomes water bearing
		MC = 25.3%			-wood debris to BOH 44.5
		MC = 45.9%			Test pit terminated at 8.5 feet below existing grade. Groundwater seepage encountered at 2.5 feet and groundwater table encountered at 5.0 feet during excavation. Caving observed from 4.0 feet to BOH.



Earth Solutions NW, LLC
 15365 N.E. 90th Street, Suite 100
 Redmond, Washington 98052
 Telephone: 425-449-4704
 Fax: 425-449-4711

TEST PIT NUMBER TP-4

PROJECT NUMBER ES-7182 PROJECT NAME 1200 – 7th Ave Townhomes
 DATE STARTED 12/22/20 COMPLETED 12/22/20 GROUND ELEVATION 54 ft TEST PIT SIZE _____
 EXCAVATION CONTRACTOR NW Excavating GROUND WATER LEVELS:
 EXCAVATION METHOD _____ ∇ AT TIME OF EXCAVATION 5.0 ft
 LOGGED BY SES CHECKED BY KDH AT END OF EXCAVATION ---
 NOTES Depth of Topsoil & Sod 6": grass AFTER EXCAVATION ---

DEPTH (ft)	SAMPLE TYPE NUMBER	TESTS	U.S.C.S.	GRAPHIC LOG	MATERIAL DESCRIPTION		
0			TPSL		Dark brown TOPSOIL, minimal root intrusions	53.5	
		MC = 8.5%	SP		Black poorly graded SAND, medium dense, damp		
		MC = 14.8%					
5						-groundwater table (after excavation) ∇ -moderate caving to BOH -groundwater table (during excavation)	
		MC = 28.8%				47.0	





Test pit terminated at 7.0 feet below existing grade. Groundwater table stabilized at 4.0 feet during excavation. Caving observed from 4.0 feet to BOH.



Earth Solutions NW, LLC
 15365 N.E. 90th Street, Suite 100
 Redmond, Washington 98052
 Telephone: 425-449-4704
 Fax: 425-449-4711

TEST PIT NUMBER TP-5

PROJECT NUMBER ES-7182 PROJECT NAME 1200 – 7th Ave Townhomes
 DATE STARTED 12/22/20 COMPLETED 12/22/20 GROUND ELEVATION 54 ft TEST PIT SIZE _____
 EXCAVATION CONTRACTOR NW Excavating GROUND WATER LEVELS:
 EXCAVATION METHOD _____ AT TIME OF EXCAVATION ---
 LOGGED BY SES CHECKED BY KDH AT END OF EXCAVATION ---
 NOTES Depth of Topsoil & Sod 12": grass AFTER EXCAVATION ---

DEPTH (ft)	SAMPLE TYPE NUMBER	TESTS	U.S.C.S.	GRAPHIC LOG	MATERIAL DESCRIPTION	
0						
			TPSL		Dark brown TOPSOIL, shallow root intrusions (Fill)	53.0
			Fill		Construction debris (bricks, wood) (Fill)	51.5
5		MC = 39.3% Fines = 71.9%	ML		Gray sandy SILT, stiff, wet -infiltration test [USDA Classification: slightly gravelly LOAM] -groundwater seepage -moderate caving to BOH	49.0
		MC = 34.7%	SP		Black poorly graded SAND, medium dense, wet -interbedded silt layers -wood pieces present in silt	
		MC = 22.2% Fines = 1.3%			[USDA Classification: slightly gravelly SAND]	45.0

Test pit terminated at 9.0 feet below existing grade. Groundwater seepage encountered at 3.5 feet during excavation. Caving observed from 4.0 feet to BOH.



Earth Solutions NW, LLC
 15365 N.E. 90th Street, Suite 100
 Redmond, Washington 98052
 Telephone: 425-449-4704
 Fax: 425-449-4711

TEST PIT NUMBER TP-6

PAGE 1 OF 1

PROJECT NUMBER ES-7182 PROJECT NAME 1200 – 7th Ave Townhomes
 DATE STARTED 12/22/20 COMPLETED 12/22/20 GROUND ELEVATION 54 ft TEST PIT SIZE _____
 EXCAVATION CONTRACTOR NW Excavating GROUND WATER LEVELS:
 EXCAVATION METHOD _____ ∇ AT TIME OF EXCAVATION 7.0 ft
 LOGGED BY SES CHECKED BY KDH AT END OF EXCAVATION ---
 NOTES Depth of Topsoil & Sod 12": grass AFTER EXCAVATION ---

DEPTH (ft)	SAMPLE TYPE NUMBER	TESTS	U.S.C.S.	GRAPHIC LOG	MATERIAL DESCRIPTION	
0						
			TPSL		Dark brown TOPSOIL, minimal root intrusions (Fill)	53.0
			Fill		Construction debris in ML (bricks, wood) (Fill)	51.5
		MC = 41.1%	ML		Gray sandy SILT, stiff, wet -mottled texture -groundwater seepage, moderate caving to BOH	49.0
5			SP-SM		Black poorly graded SAND with silt, medium dense, wet -interbedded ML layers 1.5" thick ∇ -groundwater table	46.0

MC = 36.5%
 Test pit terminated at 8.0 feet below existing grade. Groundwater table encountered at 7.0 feet and groundwater seepage encountered at 3.5 feet during excavation. Caving observed from 3.5 feet to BOH.



Earth Solutions NW, LLC
 15365 N.E. 90th Street, Suite 100
 Redmond, Washington 98052
 Telephone: 425-449-4704
 Fax: 425-449-4711

GRAIN SIZE DISTRIBUTION

PROJECT NUMBER ES-7182

PROJECT NAME 1200 - 7th Ave Townhomes

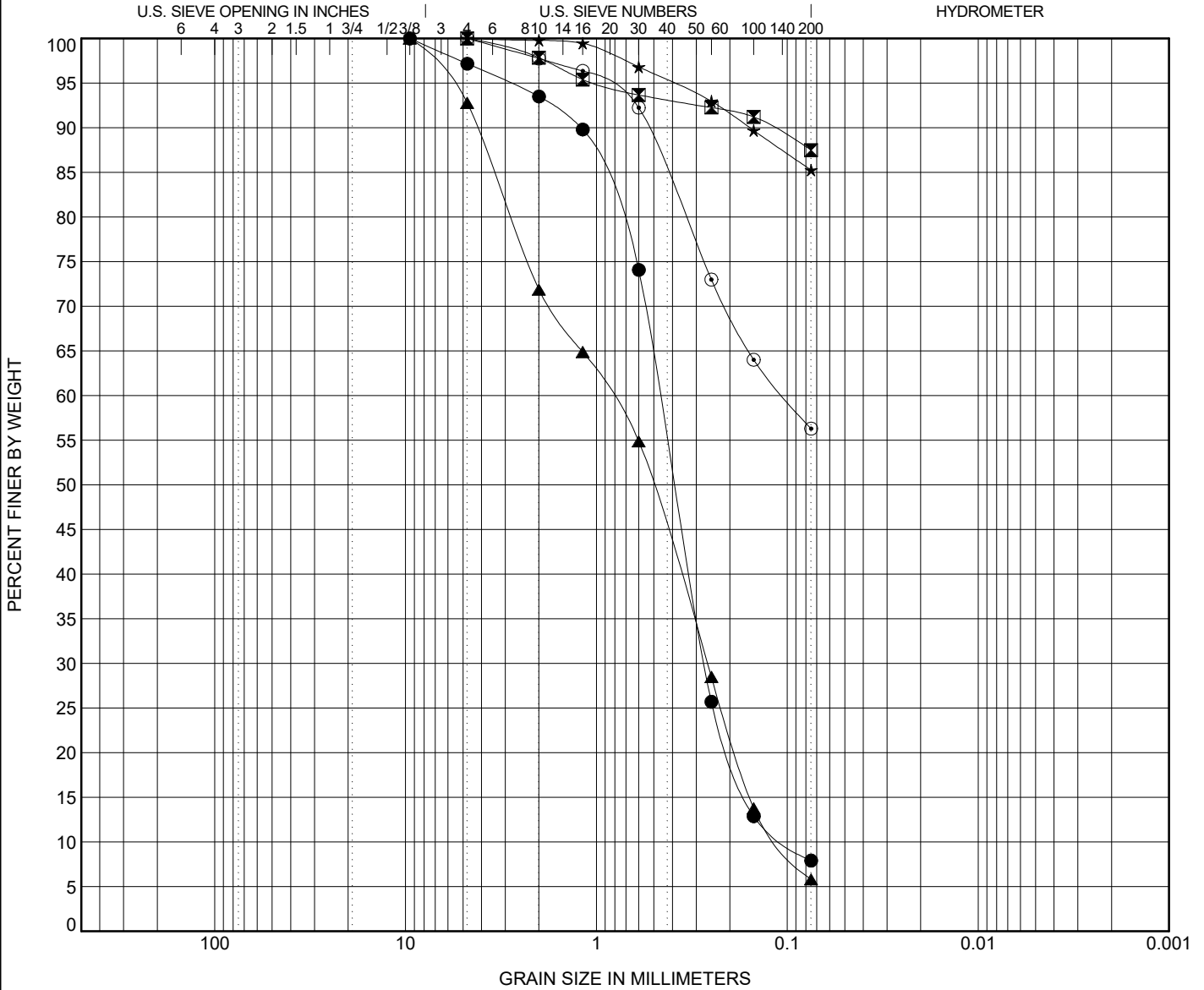

COBBLES	GRAVEL		SAND			SILT OR CLAY
	coarse	fine	coarse	medium	fine	

Specimen Identification			Classification						Cc	Cu		
●	TP-01	3.0ft.	USDA: Dark Gray Slightly Gravelly Sand. USCS: SP-SM.						1.56	4.63		
☒	TP-02	1.5ft.	USDA: Gray Slightly Gravelly Loam. USCS: ML.									
▲	TP-02	5.0ft.	USDA: Dark Gray Gravelly Sand. USCS: SP-SM.						0.75	7.86		
★	TP-02	7.0ft.	USDA: Gray Slightly Gravelly Loam. USCS: ML.									
⊙	TP-03	1.0ft.	USDA: Brown Slightly Gravelly Loam. USCS: Sandy ML.									
Specimen Identification			D100	D90	D60	D30	D10	LL	PL	PI	%Silt	%Clay
●	TP-01	3.0ft.	9.5	1.215	0.465	0.27	0.1				7.9	
☒	TP-02	1.5ft.	4.75	0.12							87.5	
▲	TP-02	5.0ft.	9.5	4.232	0.849	0.263	0.108				5.8	
★	TP-02	7.0ft.	4.75	0.157							85.3	
⊙	TP-03	1.0ft.	4.75	0.542	0.105						56.3	

GRAIN SIZE USDA WITH D90 ES-7182 1200 - 7TH AVE TOWNHOMES.GPJ GINT US LAB.GDT 4/9/20



Earth Solutions NW, LLC
 15365 N.E. 90th Street, Suite 100
 Redmond, Washington 98052
 Telephone: 425-449-4704
 Fax: 425-449-4711

GRAIN SIZE DISTRIBUTION

PROJECT NUMBER ES-7182

PROJECT NAME 1200 - 7th Ave Townhomes

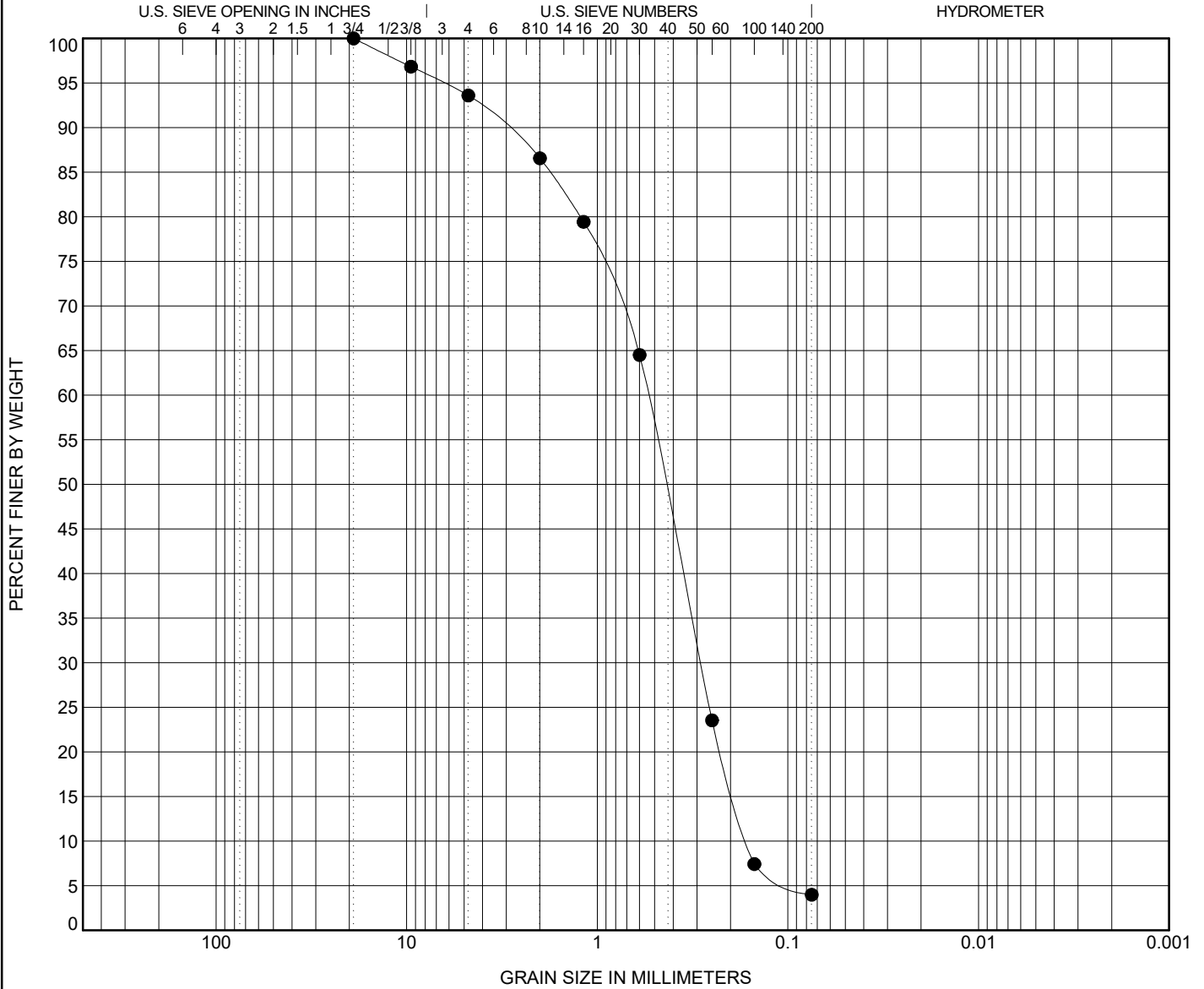

COBBLES	GRAVEL		SAND			SILT OR CLAY
	coarse	fine	coarse	medium	fine	

Specimen Identification		Classification							Cc	Cu
●	TP-03 3.0ft.	UDSA: Dark Gray Slightly Gravelly Coarse Sand. USCS: SP.							0.93	3.35

Specimen Identification		D100	D90	D60	D30	D10	LL	PL	PI	%Silt	%Clay
●	TP-03 3.0ft.	19	3.051	0.545	0.287	0.163				4.0	

GRAIN SIZE USDA WITH D90 ES-7182 1200 - 7TH AVE TOWNHOMES.GPJ GINT US LAB.GDT 4/9/20



Earth Solutions NW, LLC
 15365 N.E. 90th Street, Suite 100
 Redmond, Washington 98052
 Telephone: 425-449-4704
 Fax: 425-449-4711

GRAIN SIZE DISTRIBUTION

PROJECT NUMBER ES-7182

PROJECT NAME 1200 - 7th Ave Townhomes

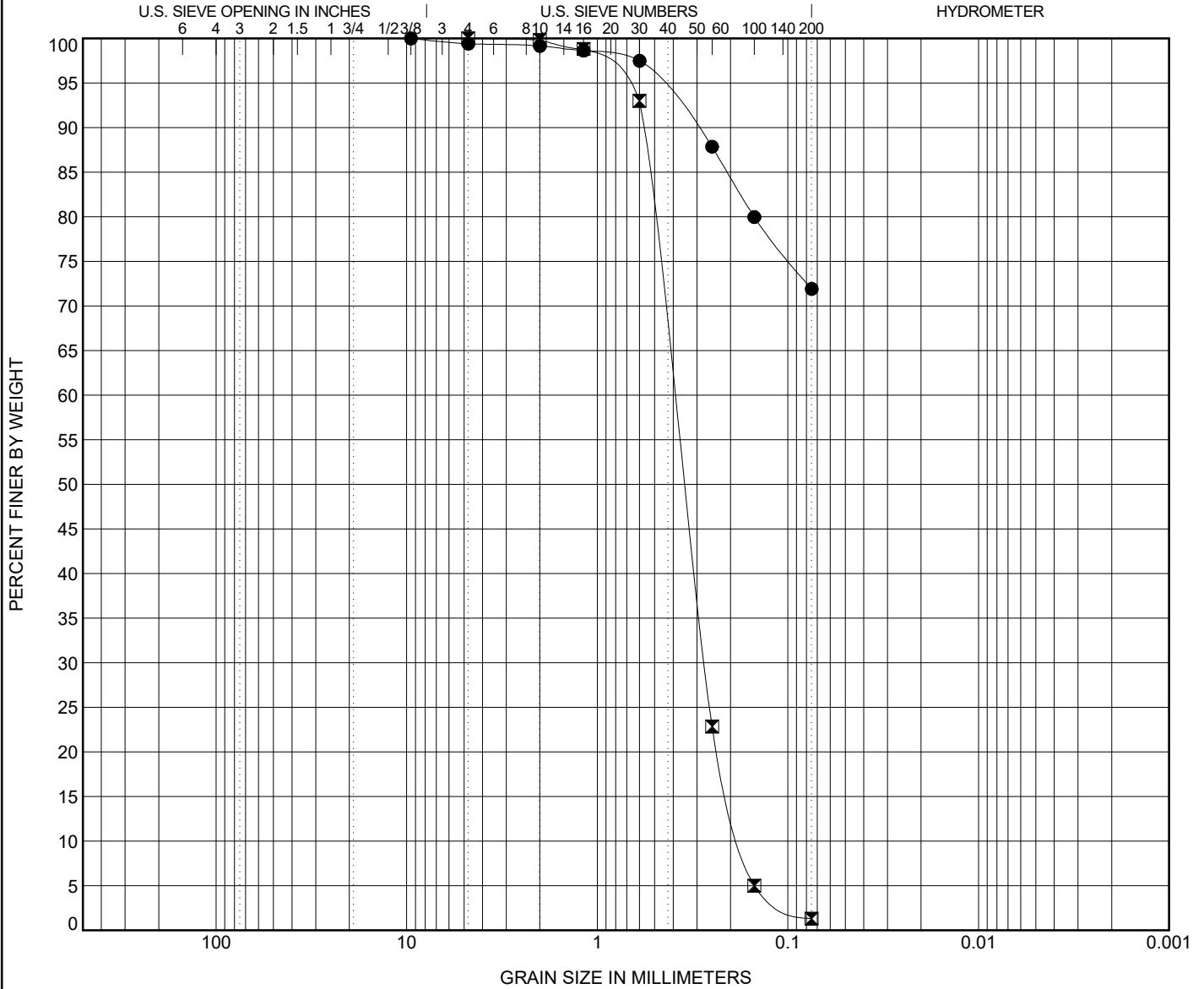

COBBLES	GRAVEL		SAND			SILT OR CLAY
	coarse	fine	coarse	medium	fine	

Specimen Identification			Classification						Cc	Cu	
●	TP-05	3.50ft.	USDA: Gray Slightly Gravelly Loam. USCS: ML with Sand.								
☒	TP-05	9.00ft.	USDA: Gray Slightly Gravelly Sand. USCS: SP.						1.09	2.30	
Specimen Identification			D100	D60	D30	D10	LL	PL	PI	%Silt	%Clay
●	TP-05	3.5ft.	9.5							71.9	
☒	TP-05	9.0ft.	4.75	0.397	0.273	0.173				1.3	

GRAIN SIZE USDA ES-7182 1200 - 7TH AVE TOWNHOMES.GPJ GINT US LAB.GDT 12/28/20