



Geotechnical Engineering
Construction Observation/Testing
Environmental Services



**GEOTECHNICAL ENGINEERING STUDY
SUNSET POINTE
2301 - 23RD STREET SOUTHEAST
PUYALLUP, WASHINGTON**

ES-5559

1805 - 136th Place N.E., Suite 201 - Bellevue, WA 98005
(425) 449-4704 Fax (425) 449-4711
www.earthsolutionsnw.com

PREPARED FOR

PETER CHEN

**January 11, 2018
Updated May 26, 2023**



**Chase G. Halsen, L.G., L.E.G.
Senior Project Geologist**

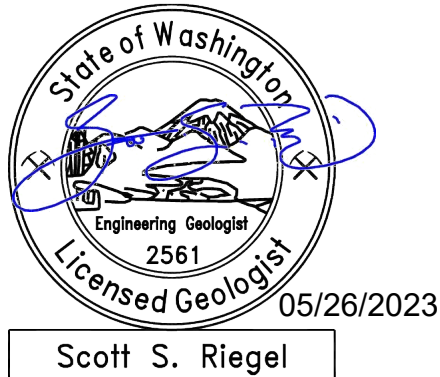

**Scott S. Riegel, L.G., L.E.G.
Associate Principal Geologist**

**GEOTECHNICAL ENGINEERING STUDY
SUNSET POINTE
2301 – 23RD STREET SOUTHEAST
PUYALLUP, WASHINGTON**

ES-5559

**Earth Solutions NW, LLC
15365 Northeast 90th Street, Suite 100
Redmond, Washington 98052
Phone: 425-449-4704 | Fax: 425-449-4711
www.earthsolutionsnw.com**

Important Information about This

Geotechnical-Engineering Report

Subsurface problems are a principal cause of construction delays, cost overruns, claims, and disputes.

While you cannot eliminate all such risks, you can manage them. The following information is provided to help.

The Geoprofessional Business Association (GBA) has prepared this advisory to help you – assumedly a client representative – interpret and apply this geotechnical-engineering report as effectively as possible. In that way, you can benefit from a lowered exposure to problems associated with subsurface conditions at project sites and development of them that, for decades, have been a principal cause of construction delays, cost overruns, claims, and disputes. If you have questions or want more information about any of the issues discussed herein, contact your GBA-member geotechnical engineer. Active engagement in GBA exposes geotechnical engineers to a wide array of risk-confrontation techniques that can be of genuine benefit for everyone involved with a construction project.

Understand the Geotechnical-Engineering Services Provided for this Report

Geotechnical-engineering services typically include the planning, collection, interpretation, and analysis of exploratory data from widely spaced borings and/or test pits. Field data are combined with results from laboratory tests of soil and rock samples obtained from field exploration (if applicable), observations made during site reconnaissance, and historical information to form one or more models of the expected subsurface conditions beneath the site. Local geology and alterations of the site surface and subsurface by previous and proposed construction are also important considerations. Geotechnical engineers apply their engineering training, experience, and judgment to adapt the requirements of the prospective project to the subsurface model(s). Estimates are made of the subsurface conditions that will likely be exposed during construction as well as the expected performance of foundations and other structures being planned and/or affected by construction activities.

The culmination of these geotechnical-engineering services is typically a geotechnical-engineering report providing the data obtained, a discussion of the subsurface model(s), the engineering and geologic engineering assessments and analyses made, and the recommendations developed to satisfy the given requirements of the project. These reports may be titled investigations, explorations, studies, assessments, or evaluations. Regardless of the title used, the geotechnical-engineering report is an engineering interpretation of the subsurface conditions within the context of the project and does not represent a close examination, systematic inquiry, or thorough investigation of all site and subsurface conditions.

Geotechnical-Engineering Services are Performed for Specific Purposes, Persons, and Projects, and At Specific Times

Geotechnical engineers structure their services to meet the specific needs, goals, and risk management preferences of their clients. A geotechnical-engineering study conducted for a given civil engineer

will not likely meet the needs of a civil-works constructor or even a different civil engineer. Because each geotechnical-engineering study is unique, each geotechnical-engineering report is unique, prepared *solely* for the client.

Likewise, geotechnical-engineering services are performed for a specific project and purpose. For example, it is unlikely that a geotechnical-engineering study for a refrigerated warehouse will be the same as one prepared for a parking garage; and a few borings drilled during a preliminary study to evaluate site feasibility will not be adequate to develop geotechnical design recommendations for the project.

Do not rely on this report if your geotechnical engineer prepared it:

- for a different client;
- for a different project or purpose;
- for a different site (that may or may not include all or a portion of the original site); or
- before important events occurred at the site or adjacent to it; e.g., man-made events like construction or environmental remediation, or natural events like floods, droughts, earthquakes, or groundwater fluctuations.

Note, too, the reliability of a geotechnical-engineering report can be affected by the passage of time, because of factors like changed subsurface conditions; new or modified codes, standards, or regulations; or new techniques or tools. *If you are the least bit uncertain* about the continued reliability of this report, contact your geotechnical engineer before applying the recommendations in it. A minor amount of additional testing or analysis after the passage of time – if any is required at all – could prevent major problems.

Read this Report in Full

Costly problems have occurred because those relying on a geotechnical-engineering report did not read the report in its entirety. Do not rely on an executive summary. Do not read selective elements only. *Read and refer to the report in full.*

You Need to Inform Your Geotechnical Engineer About Change

Your geotechnical engineer considered unique, project-specific factors when developing the scope of study behind this report and developing the confirmation-dependent recommendations the report conveys. Typical changes that could erode the reliability of this report include those that affect:

- the site's size or shape;
- the elevation, configuration, location, orientation, function or weight of the proposed structure and the desired performance criteria;
- the composition of the design team; or
- project ownership.

As a general rule, *always* inform your geotechnical engineer of project or site changes – even minor ones – and request an assessment of their impact. *The geotechnical engineer who prepared this report cannot accept*

responsibility or liability for problems that arise because the geotechnical engineer was not informed about developments the engineer otherwise would have considered.

Most of the “Findings” Related in This Report Are Professional Opinions

Before construction begins, geotechnical engineers explore a site’s subsurface using various sampling and testing procedures. *Geotechnical engineers can observe actual subsurface conditions only at those specific locations where sampling and testing is performed.* The data derived from that sampling and testing were reviewed by your geotechnical engineer, who then applied professional judgement to form opinions about subsurface conditions throughout the site. Actual sitewide-subsurface conditions may differ – maybe significantly – from those indicated in this report. Confront that risk by retaining your geotechnical engineer to serve on the design team through project completion to obtain informed guidance quickly, whenever needed.

This Report’s Recommendations Are Confirmation-Dependent

The recommendations included in this report – including any options or alternatives – are confirmation-dependent. In other words, they are not final, because the geotechnical engineer who developed them relied heavily on judgement and opinion to do so. Your geotechnical engineer can finalize the recommendations *only after observing actual subsurface conditions* exposed during construction. If through observation your geotechnical engineer confirms that the conditions assumed to exist actually do exist, the recommendations can be relied upon, assuming no other changes have occurred. *The geotechnical engineer who prepared this report cannot assume responsibility or liability for confirmation-dependent recommendations if you fail to retain that engineer to perform construction observation.*

This Report Could Be Misinterpreted

Other design professionals’ misinterpretation of geotechnical-engineering reports has resulted in costly problems. Confront that risk by having your geotechnical engineer serve as a continuing member of the design team, to:

- confer with other design-team members;
- help develop specifications;
- review pertinent elements of other design professionals’ plans and specifications; and
- be available whenever geotechnical-engineering guidance is needed.

You should also confront the risk of constructors misinterpreting this report. Do so by retaining your geotechnical engineer to participate in prebid and preconstruction conferences and to perform construction-phase observations.

Give Constructors a Complete Report and Guidance

Some owners and design professionals mistakenly believe they can shift unanticipated-subsurface-conditions liability to constructors by limiting the information they provide for bid preparation. To help prevent the costly, contentious problems this practice has caused, include the complete geotechnical-engineering report, along with any attachments or appendices, with your contract documents, *but be certain to note*

conspicuously that you’ve included the material for information purposes only. To avoid misunderstanding, you may also want to note that “informational purposes” means constructors have no right to rely on the interpretations, opinions, conclusions, or recommendations in the report. Be certain that constructors know they may learn about specific project requirements, including options selected from the report, *only* from the design drawings and specifications. Remind constructors that they may perform their own studies if they want to, and *be sure to allow enough time* to permit them to do so. Only then might you be in a position to give constructors the information available to you, while requiring them to at least share some of the financial responsibilities stemming from unanticipated conditions. Conducting prebid and preconstruction conferences can also be valuable in this respect.

Read Responsibility Provisions Closely

Some client representatives, design professionals, and constructors do not realize that geotechnical engineering is far less exact than other engineering disciplines. This happens in part because soil and rock on project sites are typically heterogeneous and not manufactured materials with well-defined engineering properties like steel and concrete. That lack of understanding has nurtured unrealistic expectations that have resulted in disappointments, delays, cost overruns, claims, and disputes. To confront that risk, geotechnical engineers commonly include explanatory provisions in their reports. Sometimes labeled “limitations,” many of these provisions indicate where geotechnical engineers’ responsibilities begin and end, to help others recognize their own responsibilities and risks. *Read these provisions closely.* Ask questions. Your geotechnical engineer should respond fully and frankly.

Geoenvironmental Concerns Are Not Covered

The personnel, equipment, and techniques used to perform an environmental study – e.g., a “phase-one” or “phase-two” environmental site assessment – differ significantly from those used to perform a geotechnical-engineering study. For that reason, a geotechnical-engineering report does not usually provide environmental findings, conclusions, or recommendations; e.g., about the likelihood of encountering underground storage tanks or regulated contaminants. *Unanticipated subsurface environmental problems have led to project failures.* If you have not obtained your own environmental information about the project site, ask your geotechnical consultant for a recommendation on how to find environmental risk-management guidance.

Obtain Professional Assistance to Deal with Moisture Infiltration and Mold

While your geotechnical engineer may have addressed groundwater, water infiltration, or similar issues in this report, the engineer’s services were not designed, conducted, or intended to prevent migration of moisture – including water vapor – from the soil through building slabs and walls and into the building interior, where it can cause mold growth and material-performance deficiencies. Accordingly, *proper implementation of the geotechnical engineer’s recommendations will not of itself be sufficient to prevent moisture infiltration.* **Confront the risk of moisture infiltration** by including building-envelope or mold specialists on the design team. **Geotechnical engineers are not building-envelope or mold specialists.**



Telephone: 301/565-2733

e-mail: info@geoprofessional.org www.geoprofessional.org



January 11, 2018
Updated May 26, 2023
ES-5559

Earth Solutions NW LLC

Geotechnical Engineering, Construction
Observation/Testing and Environmental Services

Peter Chen
4709 Memory Lane West
University Place, Washington 98488

Greetings:

Earth Solutions NW, LLC (ESNW) is pleased to present this report in support of the proposed project. Based on the results of our investigation, the proposed residential plat is feasible from a geotechnical standpoint. Our study indicates the site is underlain by areas of existing fill that overly Vashon drift glacial deposits. Light to heavy perched groundwater seepage was encountered at three test pit locations at an approximate exposure depth of about one-and-one-half to six feet below the existing ground surface. As such, it is our opinion that the contractor should be prepared to manage zones of perched groundwater seepage during construction.

In our opinion, the proposed residential structures may be constructed on conventional continuous and spread footing foundations bearing upon competent native soil, recompacted native soil, recompacted existing fill, or suitable structural fill placed directly on competent native soils. In general, native soils suitable for foundation support are anticipated to be encountered at depths of approximately two to five feet below the existing ground surface. Areas underlain by existing fill may require additional preparation efforts to establish suitable and uniform bearing conditions. Additional preparation activities will likely involve overexcavating unsuitable existing fill and restoring grades with suitable structural fill. Re-working and re-compacting the in-place fill may be feasible in areas where the fill is devoid of organic and deleterious material but must be evaluated by ESNW during grading. Areas of deeper fill (if encountered) may require additional or complete over excavation and restoration or alternative foundation support designs. In general, where loose or unsuitable soil conditions are exposed at foundation subgrade elevations, compaction of soils to the specifications of structural fill, or overexcavation and replacement with a suitable structural fill material, will be necessary.

Stormwater management is currently proposed using dispersion/level spreader BMPs for roadways and on targeted lots. Based on the soil and groundwater conditions and the results of representative in-situ infiltration testing it is our opinion that infiltration is considered infeasible in the areas tested. Further discussion of infiltration feasibility is provided in this report.

Originally completed in January 2018, this report has been updated to reflect the current proposed site layout and to provide responses to comments prepared by the City of Puyallup (see attached DRT letter). The current project proposal no longer includes the development of the northernmost site parcel (currently referred to as Parcel A). As such, soil and groundwater exposed at test pits TP-14 through TP-18 were not utilized as a basis for the recommendations and evaluations provided in this report.

Recommendations for foundation design, site preparation, drainage, and other pertinent development aspects are provided in this study. We appreciate the opportunity to be of service to you on this project. If you have questions regarding the content of this geotechnical engineering study, please call.

Sincerely,

EARTH SOLUTIONS NW, LLC



Chase G. Halsen, L.G., L.E.G
Senior Project Geologist

Table of Contents

ES-5559

	<u>PAGE</u>
<u>INTRODUCTION</u>	1
<u>General</u>	1
<u>Project Description</u>	2
<u>SITE CONDITIONS</u>	2
<u>Surface</u>	2
<u>Subsurface</u>	3
Topsoil and Fill	3
Native Soil	3
Geologic Setting	4
Groundwater	4
<u>Geologically Hazardous Areas</u>	4
Landslide Hazard	5
Erosion Hazard	6
<u>DRT Comments and Response</u>	6
<u>DISCUSSION AND RECOMMENDATIONS</u>	8
<u>General</u>	8
<u>Site Preparation and Earthwork</u>	8
Temporary Erosion Control	9
Stripping	9
In-situ and Imported Soils	9
Subgrade Preparation	10
Structural Fill	10
Slope Fill	10
<u>Temporary Excavations and Slopes</u>	11
<u>Foundations</u>	11
<u>Seismic Design</u>	12
<u>Slab-on-Grade Floors</u>	13
<u>Retaining Walls</u>	13
<u>Drainage</u>	14
Infiltration Feasibility Evaluation	14
Stormwater System	15
<u>Utility Support and Trench Backfill</u>	15
<u>Preliminary Pavement Sections</u>	15
<u>LIMITATIONS</u>	16
<u>Additional Services</u>	16

Table of Contents

Cont'd

ES-5559

GRAPHICS

Plate 1	Vicinity Map
Plate 2	Test Pit Location Plan
Plate 3	Slope Fill Detail
Plate 4	Retaining Wall Drainage Detail
Plate 5	Footing Drain Detail

APPENDICES

Appendix A	Subsurface Exploration Test Pit Logs
Appendix B	Laboratory Test Results

**GEOTECHNICAL ENGINEERING STUDY
SUNSET POINTE
2301 – 23RD STREET SOUTHEAST
PUYALLUP, WASHINGTON**

ES-5559

INTRODUCTION

General

This geotechnical engineering study (study) was prepared for the proposed residential plat to be completed at 2301 – 23rd Street Southeast in Puyallup, Washington. The purpose of this study was to provide geotechnical recommendations for currently proposed development plans. Our scope of services for completing this study included the following:

- Completion of test pits for purposes of characterizing site soils.
- Completion of laboratory testing of soil samples collected at the test pit locations.
- Conduction of engineering analyses and preparation of this report.

The following documents and maps were reviewed as part of our study preparation:

- Sunset Pointe Preliminary Plat Set, prepared by CES NW, Inc., dated May 22, 2023;
- Puyallup Municipal Code Chapter 21.06;
- Development Review Team Letter, prepared by the City of Puyallup, dated May 16, 2022;
- Online Web Soil Survey (WSS) resource, maintained by the Natural Resources Conservation Service under the United States Department of Agriculture;
- Liquefaction Susceptibility for Pierce County incorporating data from the Washington State Department of Natural Resources, dated September 2004, and;
- Geologic Map of the South Half of the Tacoma Quadrangle, Washington, by Timothy J. Walsh, 1987.

Project Description

We understand the site will be developed into a residential plat consisting of 18 residential lots and general site improvements. Stormwater management will be provided using dispersion/level spreader BMPs at some locations. At the time of report submission, building load plans were not available for review; however, based on our experience with similar developments, the proposed residential structures will likely be two to three stories in height and constructed using relatively lightly loaded wood framing supported on conventional foundations. Perimeter footing loads of about 1 to 2 kips per lineal foot (klf) are expected. Slab-on-grade loading is anticipated to be approximately 150 pounds per square foot (psf). We understand that grade fills of up to 20 feet will be necessary to achieve design elevations across the building pads and grading will occur in a stepped configuration where practical do reduce the site modifications required. Deeper excavations will likely be required to construct the stormwater pond.

If the above design assumptions are incorrect or change, ESNW should be contacted to review the recommendations provided in this report. ESNW should review the final designs to confirm that appropriate geotechnical recommendations have been incorporated into the plans.

SITE CONDITIONS

Surface

The subject site is located east of the intersection between 19th Avenue Southeast and 21st Street Southeast in Puyallup, Washington. The approximate location of the subject site is depicted on Plate 1 (Vicinity Map). The irregular-shaped property is comprised of two adjoining tax parcels (Pierce County Parcel Nos. 042035-3027) totaling approximately 9.09 acres.

The site is bordered on all sides primarily by existing residential development. A sewer and water easement is present on site, trending roughly east to west along the entire northern edge of the development area. A relay station is present within the east-central site area. Multiple barn and storage structures appear to have been present within the southern site area but had been demolished before our fieldwork. Based on our field observations, it appears that the land has been previously modified through the placement of fill material. It appears that the fill had been placed to establish an access pathway to the southern site area, to level sloping areas, and fill an existing natural trough feature. Based on our observations, it is our opinion the site modification was likely not associated with recent development. Current topography varies across the site; however, maintains an overall northerly/northeasterly declivity. Approximately 30 to 35 feet of total elevation change occurs within the proposed development area. Three existing wetlands (designated A-C on the referenced plans) are present within the central site area.

Subsurface

The subsurface explorations and in-situ filed testing consisted of the following:

- October 24, 2017: Completing 19 test pits were conducted across the entire site area (including Parcel A).
- May 15, 2019: Completing four test pits were conducted and targeted to the proposed stormwater management pond (Tract B). Three shallow groundwater monitoring piezometers were installed during this exploration.
- January 22, 2020: Completing two test pits were performed to conduct small-scale pilot infiltration testing at representative site areas. A shallow, groundwater monitoring piezometer was installed at both test pit locations.

Each exploration and in-situ testing program was observed, logged, and sampled by an ESNW representative and completed using machinery and an operator retained by our firm and completed to assess and classify subsurface soil and groundwater conditions across the site. The approximate locations of the test pits are depicted on Plate 2 (Test Pit Location Plan). Please refer to the test pit logs provided in Appendix A for a more detailed description of subsurface conditions. Representative soil samples collected at the test pit locations were analyzed in accordance with the Unified Soil Classification System (USCS) and United States Department of Agriculture (USDA) methods and procedures.

Topsoil and Fill

Topsoil was encountered generally within the upper 2 to 18 inches of existing grades at the test pit locations. The topsoil was characterized by dark brown color, the presence of fine organic material, and small root intrusions.

Fill was observed at the majority of the test pit locations, ranging in approximate depths from 1 to 13 feet below the existing ground surface (bgs). The fill was observed to be variable in nature, typically consisting of silty sand to sandy silt, and encountered in a loose to medium dense and moist condition. In general, the majority of the fill was observed to be free of debris, except isolated areas of brick and wire debris and trace organics. Due to the high variability in texture of the fill soils, ESNW should be retained to evaluate the suitability of fill encountered during construction.

Native Soil

Underlying topsoil and fill, native soils were encountered consisting of soils associated with and representative of glacial drift deposits. In general, the predominant native soil type should be considered silty sand with or without gravel (USCS: SM). However, localized areas and depositional lenses of poorly graded sand and silt (USCS: SP and ML, respectively) were encountered. The native soils were typically encountered in a medium dense and moist conditions.

Geologic Setting

The referenced geologic map resource identifies Vashon undifferentiated drift (Qdv) across the site and surrounding areas. Although not specifically characterized within the geologic map resource, Vashon drift typically consists of glacial till, glaciofluvial, and glaciolacustrine sediments. The reference WSS resource indicates soils of the Everett very gravelly sandy loam, Indianola loamy sand, and Kitsap silt loam (Map Unit Symbols: 13B, 18C, 20B, and 20C, respectively). These soil groups are typically associated with moraines, eskers, kames, and terrace landforms, derived from glacial outwash and glaciolacustrine material. The variability in the makeup of the native soils is generally consistent with that of Vashon drift.

Groundwater

Perched groundwater seepage was encountered at TP-4, TP-201, and TP-202 during the subsurface explorations. In general, the seepage was exposed at depths of about one-and-one-half to six feet bgs and characterized as light to heavy.

In our opinion, the contractor should anticipate, and be prepared to manage, zones of perched groundwater seepage during construction, especially within deeper excavations depending on the time of year grading occurs. Groundwater seepage is common within glacial sediments, particularly within relatively permeable lenses and/or atop dense to very dense, unweathered deposits. Seepage rates and elevations fluctuate depending on many factors, including precipitation duration and intensity, the time of year, and soil conditions. In general, groundwater flow rates are higher during the wetter, winter months.

ESNW is currently performing a groundwater monitoring program for the site at three of the previously installed shallow wells. The results of the program and applicable design recommendations will be provided in a summary letter separate from this report.

Geologically Hazardous Areas

In preparation of this report, we reviewed the applicable city of Puyallup mapping and geologically hazardous area code section 21.06.

Landslide Hazard

As defined in Puyallup Municipal Code (PMC) 21.06.1210, landslide and erosion hazard areas include those identified by the U.S. Department of Agriculture Natural Resources Conservation Service as having a moderate to severe, severe, or very severe erosion hazard because of natural characteristics, including vegetative cover, soil texture, slope, gradient, and rainfall patterns, or human-induced changes to natural characteristics. Landslide and erosion hazard areas include areas with the following characteristics:

- Areas that have shown mass movement during the Holocene epoch (from 10,000 years ago to the present) or that are underlain or covered by mass wastage debris of that epoch;
- Slopes that are parallel or subparallel to planes of weakness (such as bedding planes, joint systems, and fault planes) in subsurface materials;
- Slopes having gradients steeper than 80 percent subject to rock fall during seismic shaking;
- Areas potentially unstable because of stream incision or stream bank erosion;
- Areas located in a canyon, ravine, or on an active alluvial fan, presently or potentially subject to inundation by debris flows or flooding;
- Any area with a slope of 40 percent or steeper and a vertical relief of 10 or more feet, except areas composed of consolidated rock and properly engineered manmade slopes/retained fill. A slope is delineated by establishing its toe and top and measured by averaging the inclination over at least 10 feet of vertical relief;
- Areas with a severe limitation for building development because of slope conditions, according to the Natural Resource Conservations Service, and;
- Areas meeting all three of the following criteria: (A) slopes steeper than 15 percent, except that slopes of less than 15 percent may be considered erosion hazard areas if they have certain unstable soil and drainage characteristics; (B) hillsides intersecting geologic contacts with a relatively permeable sediment overlying a relatively impermeable sediment or bedrock; and (C) wet season springs or groundwater seepage.

Based on the conditions encountered during our subsurface explorations, review of available topographic information, and review of the referenced slope schematic (which includes delineations of slopes greater than 40 percent), it appears that the majority of the site does not contain a landslide hazard, as defined by the PMC, except as noted below.

Slopes of 40 percent or greater have been delineated within the central site area and are associated with the sidewalls of Wetland A and Wetland C. However, these slopes are isolated and relatively minor in extent. Based on a review of the referenced preliminary plat plan set, a 25-foot buffer has been applied to each respective steep slope feature. Although the buffer appears to intersect the northwest corner of Lot 14, it is outside of the proposed building pad area; therefore, is outside future structural improvements.

In general, the development areas of the site do not contain a landslide hazard. Although some areas on site may meet the PMC criteria for landslide hazard, they are isolated and limited in occurrence. In our opinion, the site does not contain a hazard that would preclude successful development. However, remediation of unsuitable existing soils and groundwater drainage improvements will likely be necessary to assist in maintaining or improving post-construction soil stability. As such, ESNW should be present during grading activities to help identify areas of unsuitable soil and groundwater seepage and provide such mitigation recommendations. From a geotechnical standpoint, provided the recommendations of the referenced report and those contained within this letter are incorporated into the project designs, it is our opinion, based on our understanding of the current scope, the project can be developed as is currently proposed.

Erosion Hazard

As delineated in Puyallup Municipal Code (PMC) 21.06.1210, erosion hazard areas include those identified by the U.S. Department of Agriculture Natural Resources Conservation Service as having a moderate to severe, severe, or very severe erosion hazard because of natural characteristics, including vegetative cover, soil texture, slope, gradient, and rainfall patterns, or human-induced changes to natural characteristics.

Site soils are considered to have moderate to severe erosion potential when exposed to precipitation. In our opinion, provided appropriate temporary and permanent erosion and sediment control (ESC) measures are incorporated into final designs, the potential for erosion will remain low both during and after construction. Site BMPs and other means of sediment and surface flow control measures should be actively maintained during construction to ensure proper performance and functions. While seasonal grading restrictions may not be required for this project, we recommend the developer be prepared to employ enhanced ESC measures during the rainy season and be prepared to suspend grading activities if adequate BMPs cannot perform as intended during intense precipitation.

Provided the above recommendations and considerations are included with the construction plan and sequence, it is our opinion that the proposed development will not adversely affect soil stability on adjacent properties. Please note that our evaluation and corresponding lot recommendations are based on plans and site layouts made available to ESNW during report preparation. If site layout plans change, ESNW should be notified to provide updated recommendations.

DRT Comments and Response

For ease of review and clarity, this section of the report will be focused on responding to geotechnically related jurisdictional comments provided in the referenced DRT letter. Some elements of this response may be a duplicated from the discussion, evaluations, and/or recommendations provided in this report.

Planning and Review Comment 4: *A 25' native growth protection area (NGPA) shall be provided on the rear of lot 13 due to slopes and protective buffer areas of 40% (or more) slopes and wetlands, per the Geotech report. These areas shall be landscaped and landscape plan shall be provided for these lots during final landscape plan and approval. February 2022, staff follow up comment: Please revise the lot layout with this protection area shown on the plat sheet(s) as 40% (or more) area (using the same call out as on Tract A) and show buffer setback.*

ESNW Response: As indicated on the referenced plan set, a NGPA easement of 35' feet has been incorporated along the east property line and encompasses all or a part of Lots 8 through 13. Furthermore, a 25-foot buffer has been incorporated in sloping areas that meet or exceed 40 percent, both of which are located around Wetland A or C. The slope buffer in proximity to Wetland A encompasses a part of Lot 14; however does not encroach into the building envelope for that lot. With respect to Wetland C, the slope buffer does not encroach on any adjacent lot areas.

Engineering Review Comment 2: *First and foremost, there will be no further review of the civil portion of the Major Plat due to the non-response to repeated requests for detailed long term groundwater monitoring. In addition, 2 test pits are not adequate for a site this size. Infiltration must be shown as infeasible in order for the project to claim that it is infeasible and not use it. Provide detailed account of testing and tabulated results.*

ESNW Response: Site subsurface conditions were explored in October 2017, May 2019, and January 2020 and indicated variability concerning soil types present and grain size distribution across the site. Per USDA testing methods and procedures, native soils are also classified as slightly gravelly sand, gravelly loamy coarse sand, very gravelly loamy sand, and loam. Fines contents were about 6 percent within the sands, 26 to 40 percent within the sandy loam, and 58 to 98 percent within the gravelly loam and loam, as indicated by the sieve results of representative samples. To further evaluate site infiltration potential, two small-scale pilot infiltration tests (PITs) were performed in January 2020. The following table depicts each infiltration test location, encountered soil type, test depth, measured rate, appropriate safety factors, and recommended design rate.

Location	Soil Type	Test Depth (ft bgs)	Measured Rate (in/hr)	Correction Factors			Recommended Design Rate (in/hr)
				CF _v	CF _t	CF _m	
TP-201	ML	4.0	0	0.33	0.5	0.9	0
TP-202	ML	4.0	0	0.33	0.5	0.9	0

In accordance with our previous evaluations and recommendations, it is our opinion that infiltration be considered infeasible for the proposed project. Based on the soil and groundwater conditions exposed during each subsurface exploration, and the observed field infiltration rate of zero in/hr. at both PIT locations, it is our opinion that infiltration infeasibility has been sufficiently demonstrated.

Engineering Review Comment 6b: *The stormwater pond is located within a steep slope buffer. Per the DOE stormwater manual, the facility shall not be located above a slope that exceeds 15 percent.*

Engineering Review Comment 6d: The stormwater pond will be a City-owned infrastructure. The city does not accept its current location above a steep slope that leads to a wetland. This configuration will likely cause additional maintenance and has a potential for failure over time. The pond shall be relocated.

ESNW Response: From a geotechnical standpoint, construction of the stormwater pond at the proposed location may be considered feasible provided that lateral water migration can be sufficiently prevented. In our opinion, this can be achieved by including a low-permeable liner in the pond construction. Liners can consist of a geo-membrane or compacted soil that meets the requirements of the governing stormwater manual.

Engineering Review Comment 7: *Does the soils within the wetland tract have any capabilities of infiltrating?*

ESNW Response: From a geotechnical standpoint, infiltration should not be considered within the wetland areas. The presence of perennial, ponded water indicates that the wetland area is underlying by a confining or restrictive layer. Vertical transmission of water may occur; however, based on the soil conditions encountered at the test pit locations and or field observations, it would likely be a nearly negligible amount in concurrence with lateral water migration, however, it is not expected to the degree which would allow for successful, targeted infiltration designs to the area.

DISCUSSION AND RECOMMENDATIONS

General

Based on the results of our investigation, the construction of the proposed residential development is feasible from a geotechnical standpoint. The primary geotechnical considerations associated with the proposed development include foundation support, slab-on-grade subgrade support, the suitability of using on-site soils as structural fill, and construction of the stormwater facility(s).

Site Preparation and Earthwork

Initial site preparation activities will consist of installing temporary erosion control measures, establishing grading limits, and performing clearing and site stripping. Subsequent earthwork activities will involve mass site grading and related infrastructure improvements.

Temporary Erosion Control

The following temporary erosion control measures are offered:

- Temporary construction entrances and drive lanes, consisting of at least six inches of quarry spalls, should be considered to both minimize off-site soil tracking and provide a stable access entrance surface. The placement of a geotextile fabric beneath the quarry spalls will provide greater stability if needed. Existing asphalt/gravel drive lanes can be considered for use as a temporary construction entrance and should be observed by ESNW before construction.
- Silt fencing should be placed around the site perimeter.
- When not in use, soil stockpiles should be covered or otherwise protected.
- Temporary measures for controlling surface water runoff, such as interceptor trenches, sumps, or interceptor swales, should be installed before beginning earthwork activities.
- Dry soils disturbed during construction should be wetted to minimize dust.

Additional BMPs, as specified by the project civil engineer and indicated on the plans, should be incorporated into construction activities. Temporary erosion control measures should be continually maintained and improved to provide proper function over the course of construction.

Stripping

Topsoil was encountered generally within the upper 2 to 18 inches of existing grades at the test pit locations. Based on the encountered conditions, an average topsoil thickness of about eight to nine inches may be assumed ESNW should be retained to observe site stripping activities at the time of construction so that the degree of required stripping may be assessed. The exposed subgrade may still possess root elements, other organic material, or be present in a loose condition. As such, ESNW should evaluate the exposed soil subgrade to determine if further stripping or in-situ compaction efforts prior to fill operations or finish grading is necessary. Over-stripping should be avoided, as it is unnecessary and may result in increased project development costs. Topsoil and organic-rich soil are neither suitable for foundation support nor for use as structural fill. Topsoil and organic-rich soil may be used in non-structural areas if desired.

In-situ and Imported Soils

On-site soils are highly moisture sensitive; therefore, successful use as structural fill largely being dictated by the moisture content at the time of placement and compaction. Remedial measures, such as soil aeration and/or cement treatment (where allowed by the local jurisdiction or utility district), may be necessary as part of site grading and earthwork activities. Existing fill soils to be used within structural applications must be free of deleterious debris, especially concerning construction-like debris and organic material. If the on-site soils cannot be successfully compacted, the use of an imported soil may be necessary. In our opinion, a contingency should be provided in the project budget for the export of soil that cannot be successfully compacted as structural fill if grading activities take place during periods of extended rainfall activity. Soils with fine contents greater than 5 percent typically degrade rapidly when exposed to periods of rainfall.

Imported soil intended for use as structural fill should consist of a well-graded, granular soil with a moisture content that is at (or slightly above) the optimum level. During wet weather conditions, imported soil intended for use as structural fill should consist of a well-graded, granular soil with a fines content of 5 percent or less (where the fines content is defined as the percent passing the Number 200 sieve, based on the minus three-quarter-inch fraction).

Subgrade Preparation

Following site stripping, cuts and fills will be completed to establish proposed subgrade elevations across the site. To establish a suitable subgrade for structural elements, recompaction of existing fill soils will likely be necessary for some areas. Due to the variable thickness and extent of the existing fill, it is our opinion that structural elements within the deeper fill areas be underlain by at least four feet of structural fill. It may be possible to recompact and reuse existing fill provided that it is free of deleterious material and contain a moisture content that is near optimum and is approved by ESNW at the time of placement and compaction.

Subgrades founded in competent native soils can likely be compacted in situ with mechanical equipment until a uniformly firm and unyielding condition is achieved. ESNW should observe the subgrade(s) during initial site preparation activities to confirm soil conditions are as anticipated and to provide supplementary recommendations for subgrade preparation, as necessary.

Please note the above considerations are based on current site layout plans available to ESNW, as depicted on the Test Pit Location Plan attached to this report. Should site layout designs change, ESNW should be informed and allowed to reevaluate necessary preparation efforts in relation to corresponding Lot numbers.

Structural Fill

Structural fill is defined as compacted soil placed in the foundation, slab-on-grade, roadway, permanent slope, retaining wall, and utility trench backfill areas. Soils placed in structural areas should be placed in loose lifts of 12 inches or less and compacted to a relative compaction of 95 percent, based on the laboratory maximum dry density as determined by the Modified Proctor Method (ASTM D1557). Soils intended for use as structural fill should be generally free of organic and deleterious material. For soil placed in utility trenches underlying structural areas, compaction requirements are dictated by the local city, county, or utility district, and are typically specified to a relative compaction of at least 95 percent.

Slope Fill

Structural fill placed along sloping areas (where a "sloping area" is defined as an area inclined at 15 percent or steeper) should be placed on a level bench as depicted on Plate 3 (Slope Fill Detail). Benches must be "keyed" into the slope and subsequently filled and compacted with suitable structural fill before continuing to the next bench. Sloping finish grades should be "overbuilt" using a bench-style fill and cut to the design gradient to ensure a permanent compacted slope face is maintained. ESNW should observe structural fill placement to confirm subgrade conditions and provide additional drainage recommendations, as necessary.

Temporary Excavations and Slopes

Excavation activities will likely expose loose to medium dense fill and weathered native soils that transition to medium dense to dense native soils at depth. Based on the soil conditions observed at the test pit locations, the following allowable temporary slope inclinations, as a function of horizontal to vertical (H:V) inclination, may be used. The applicable Federal Occupation Safety and Health Administration (OSHA) and Washington Industrial Safety and Health Act (WISHA) soil classifications are also provided:

- Loose to medium dense soil 1.5H:1V (Type C)
- Areas containing groundwater seepage 1.5H:1V (Type C)
- Dense to very dense native soil 0.75H:1V (Type A)

Steeper temporary slope inclinations within undisturbed, very dense native deposits may be feasible based on the soil and groundwater conditions exposed within the excavations. Steeper inclinations may be considered and must be subsequently approved, by ESNW at the time of grading.

Permanent slopes should be planted with vegetation to enhance stability and minimize erosion and should maintain a maximum gradient of 2H:1V or inclination prescribed by the governing jurisdiction. The presence of perched groundwater may cause localized sloughing of temporary slopes due to excess seepage forces. An ESNW representative should observe temporary and permanent slopes to confirm the slope inclinations are suitable for the exposed soil conditions and to provide additional excavation and slope recommendations, as necessary. If the recommended temporary slope inclinations cannot be achieved, temporary shoring may be necessary to support excavations.

Foundations

In our opinion, the proposed residential structures may be constructed on conventional continuous and spread footing foundations bearing upon competent native soil, recompacted native soil, recompacted existing fill, or suitable structural fill placed directly on competent native soils. In general, native soils competent for foundation support are anticipated to be encountered at approximate depths of two to five feet below the existing ground surface elevation. Areas underlain by existing fill may require additional preparation techniques to establish suitable and uniform bearing conditions, such as overexcavating unsuitable existing fill and restoring grades with suitable structural fill. Re-working and re-compacting the in-place fill may be feasible in areas where the fill is devoid of organic and deleterious material but must be evaluated by ESNW during grading. Areas of deeper fill may require additional or complete over excavation and restoration or alternative foundation support implementations (see Subgrade Preparation section of the report). In general, where loose or unsuitable soil conditions are exposed at foundation subgrade elevations, compaction of soils to the specifications of structural fill, or overexcavation and replacement with a suitable structural fill material, will be necessary.

Provided the foundations will be supported as described above, the following parameters may be used for the design:

- Allowable soil bearing capacity 2,500 psf
- Passive earth pressure 300 pcf (equivalent fluid)
- Coefficient of friction 0.40

A one-third increase in the allowable soil bearing capacity may be assumed for short-term wind and seismic loading conditions. The above passive pressure and friction values include a factor-of-safety of 1.5. With structural loading as expected, total settlement in the range of one inch and differential settlement of about one-half inch is anticipated. The majority of the settlements should occur during construction, as dead loads are applied.

Seismic Design

The 2018 International Building Code (2018 IBC) recognizes the most recent edition of the Minimum Design Loads for Buildings and Other Structures manual (ASCE 7-16) for seismic design, specifically concerning earthquake loads. Based on the soil conditions encountered at the test pit locations, the parameters and values provided below are recommended for seismic design per the 2018 IBC.

Parameter	Value
Site Class	D*
Mapped short period spectral response acceleration, $S_s (g)$	1.255
Mapped 1-second period spectral response acceleration, $S_1 (g)$	0.432
Short period site coefficient, F_a	1.0
Long period site coefficient, F_v	1.868 [†]
Adjusted short period spectral response acceleration, $S_{MS} (g)$	1.255
Adjusted 1-second period spectral response acceleration, $S_{M1} (g)$	0.807 [†]
Design short period spectral response acceleration, $S_{DS} (g)$	0.837
Design 1-second period spectral response acceleration, $S_{D1} (g)$	0.538 [†]

* Assumes medium dense native soil conditions, encountered to a maximum depth of 18 feet bgs during the October 207, May 2019, and January 2020 field exploration, remain medium dense (if not become denser) to at least 100 feet bgs.

† Values assume F_v may be determined using linear interpolation per Table 11.4-2 in ASCE 7-16.

As indicated in the table footnote, several of the seismic design values provided above are dependent on the assumption that site-specific ground motion analysis (per Section 11.4.8 of ASCE 7-16) will not be required for the subject project. ESNW recommends the validity of this assumption be confirmed at the earliest available opportunity during the planning and early design stages of the project. Further discussion between the project structural engineer, the project owner, and ESNW may be prudent to determine the possible impacts to the structural design due to increased earthquake load requirements under the 2018 IBC. ESNW can provide additional consulting services to aid with design efforts, including supplementary geotechnical and geophysical investigation, upon request.

Liquefaction is a phenomenon where saturated or loose soil suddenly loses internal strength and behaves as a fluid. This behavior is in response to increased pore water pressures resulting from an earthquake or another intense ground shaking. In our opinion, site susceptibility to liquefaction may be considered low. The depth of the regional groundwater table and the encountered in-situ density of the native soil were the primary bases for this opinion.

Slab-on-Grade Floors

Slab-on-grade floors for the proposed residential structures should be supported on a well-compacted, firm, and unyielding subgrade. Where feasible, competent native soil exposed at the slab-on-grade subgrade level can likely be compacted in situ to the specifications of structural fill. Unstable or yielding areas of the subgrade should be recompacted, or overexcavated and replaced with suitable structural fill, before construction of the slab.

A capillary break consisting of a minimum of four inches of free-draining crushed rock or gravel should be placed below the slab. The free-draining material should have a fines content of 5 percent or less (where the fines content is defined as the percent passing the Number 200 sieve, based on the minus three-quarter-inch fraction). In areas where slab moisture is undesirable, the installation of a vapor barrier below the slab should be considered. If a vapor barrier is to be utilized, it should be a material specifically designed for use as a vapor barrier and should be installed in accordance with the specifications of the manufacturer.

Retaining Walls

Retaining walls must be designed to resist earth pressures and applicable surcharge loads. The following parameters may be used for the design:

- Active earth pressure (yielding condition) 35 pcf (equivalent fluid)
- At-rest earth pressure (restrained condition) 55 pcf
- Traffic surcharge (passenger vehicles) 70 psf (rectangular distribution)*
- Passive earth pressure 300 pcf (equivalent fluid)
- Coefficient of friction 0.40
- Seismic surcharge 8H psf**

* Where applicable.

** Where H equals the retained height (in feet).

The above design parameters are based on a level backfill condition and level grade at the wall toe. Revised design values will be necessary if sloping grades are to be used above or below retaining walls. Additional surcharge loading from adjacent foundations, sloped backfill, or other relevant loads should be included in the retaining wall design.

Retaining walls should be backfilled with free-draining material that extends along the height of the wall and a distance of at least 18 inches behind the wall. The upper 12 inches of the wall backfill may consist of a less permeable soil if desired. A perforated drainpipe should be placed along the base of the wall and connected to an approved discharge location. A typical retaining wall drainage detail is provided on Plate 4. If drainage is not provided, hydrostatic pressures should be included in the wall design.

Drainage

Based on our field observations, isolated zones of perched groundwater seepage should be anticipated within site excavations depending on the time of year grading occurs. Temporary measures to control surface water runoff and groundwater seepage during construction would likely involve interceptor trenches and sumps. ESNW should be consulted during preliminary grading to identify areas of seepage and provide recommendations to reduce the potential for instability related to seepage effects.

Finish grades must be designed to direct surface drain water away from structures and slopes. Water must not be allowed to pond adjacent to structures or slopes. In our opinion, foundation drains should be installed along building perimeter footings. A typical foundation drain detail is provided on Plate 5.

Infiltration Feasibility Evaluation

Site subsurface conditions were initially explored in October 2017, May 2019, and January 2020 and indicated variability concerning soil types present and grain size distribution across the site. Per USDA testing methods and procedures, native soils are also classified as slightly gravelly sand, gravelly loamy coarse sand, very gravelly loamy sand, and loam. Fines contents were about 6 percent within the sands, 26 to 40 percent within the sandy loam, and 58 to 98 percent within the gravelly loam and loam, as indicated by the sieve results of representative samples. To further evaluate site infiltration potential, two small-scale pilot infiltration tests (PITs) were performed in January 2020. The following table depicts each infiltration test location, encountered soil type, test depth, measured rate, appropriate safety factors, and recommended design rate.

Location	Soil Type	Test Depth (ft bgs)	Measured Rate (in/hr)	Correction Factors			Recommended Design Rate (in/hr)
				CF _v	CF _t	CF _m	
TP-201	ML	4.0	0	0.33	0.5	0.9	0
TP-202	ML	4.0	0	0.33	0.5	0.9	0

In accordance with our previous evaluations and recommendations, it is our opinion that infiltration be considered infeasible for the proposed project. Based on the soil and groundwater conditions exposed during each subsurface exploration, and the observed field infiltration rate of zero in/hr. at both PIT locations, it is our opinion that infiltration infeasibility has been sufficiently demonstrated.

Stormwater System

We understand that roof runoff will be collected and conveyed to individual lot dispersion/level spreader BMPs. The intent of this configuration is to reduce the potential for concentrated discharge and recharge the site wetland/pond areas to preserve functions and values of those features. In our opinion, this approach is acceptable from a geotechnical standpoint.

Utility Support and Trench Backfill

In our opinion, on-site soils will generally be suitable for the support of utilities. Remedial measures may be necessary for some areas to provide support for utilities, such as overexcavation and replacement with structural fill and/or placement of geotextile fabric. Groundwater seepage may be encountered within utility excavations, and caving of trench walls may occur where groundwater is encountered. Depending on the time of year and conditions encountered, dewatering, as well as temporary trench shoring, may be necessary during utility trench excavation and installation.

Successful use will depend on the soil's moisture content at the time of placement and compaction. The silt soils encountered at our test pit locations is not suitable for utility trench backfill. Moisture conditioning of the soils may be necessary at some locations before use as structural fill. Each section of the utility lines must be adequately supported in the bedding material. Utility trench backfill should consist of and be placed and compacted to the specifications of structural fill as previously detailed in this report, or to the applicable specifications of the governing jurisdiction or agency.

Preliminary Pavement Sections

The performance of site pavements is largely related to the condition of the underlying subgrade. To ensure adequate pavement performance, the subgrade should be in a firm and unyielding condition when subjected to proofrolling with a loaded dump truck. Structural fill in pavement areas should be compacted to the specifications previously detailed in this report. Soft, wet, or otherwise unsuitable subgrade areas may still exist after base grading activities. Areas containing unsuitable or yielding subgrade conditions will require remedial measures, such as over-excavation and/or placement of thicker crushed rock or structural fill sections, before pavement.

We anticipate new pavement sections will be subjected primarily to passenger vehicle traffic. For lightly loaded pavement areas subjected primarily to passenger vehicles, the following preliminary pavement sections may be considered:

- A minimum of two inches of hot mix asphalt (HMA) placed over four inches of crushed rock base (CRB), or;
- A minimum of two inches of HMA placed over three inches of asphalt-treated base (ATB).

For heavy-loaded pavement areas such as main interior access roads and areas subject to occasional large commercial vehicle traffic, the following preliminary pavement sections may be considered:

- Three inches of HMA placed over six inches of CRB, or;
- Three inches of HMA placed over three inches of ATB.

The HMA, ATB, and CRB materials should conform to WSDOT specifications. All soil base material should be compacted to a relative compaction of 95 percent, based on the laboratory maximum dry density as determined by a modified proctor test (ASTM D1557). Final pavement design recommendations, including recommendations for heavy traffic areas, access roads, and frontage improvement areas, can be provided once final traffic loading has been determined. Road standards utilized by the governing jurisdiction may supersede the recommendations provided in this report. If the roadway will be constructed with an inverted crown, additional drainage recommendations may be necessary, as evaluated and recommended by ESNW at the time of construction.

LIMITATIONS

The recommendations and conclusions provided in this study are professional opinions consistent with the level of care and skill that is typical of other members in the profession currently practicing under similar conditions in this area. A warranty is neither expressed nor implied. Variations in the soil and groundwater conditions observed at the test pit locations may exist and may not become evident until construction. ESNW should reevaluate the conclusions provided in this study if variations are encountered.

Additional Services

ESNW should have an opportunity to review final project plans with respect to the geotechnical recommendations provided in this report. ESNW should also be retained to provide testing and consultation services during construction.

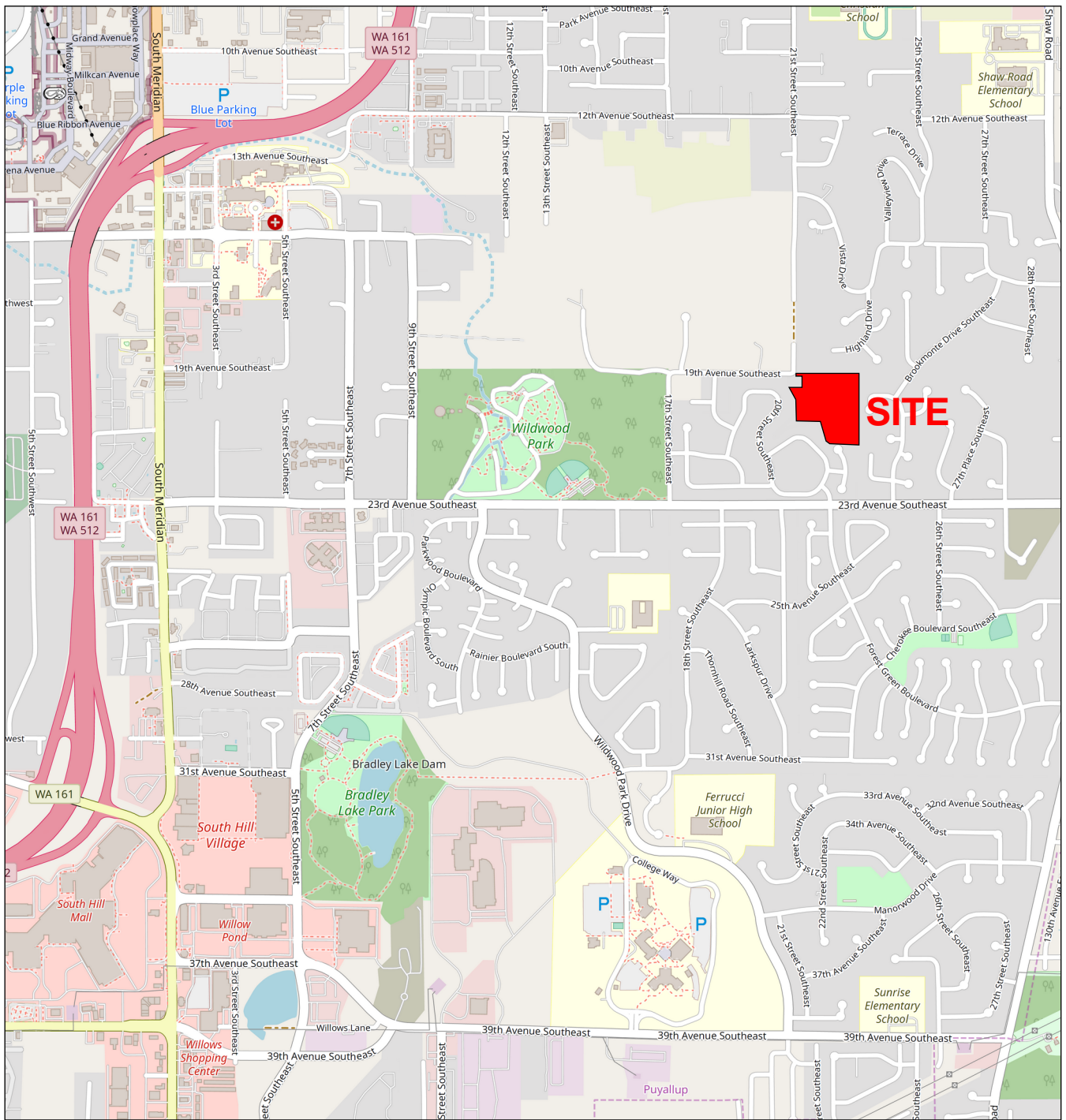

Reference:
 Pierce County, Washington
 OpenStreetMap.org



NOTE: This plate may contain areas of color. ESNW cannot be responsible for any subsequent misinterpretation of the information resulting from black & white reproductions of this plate.



Earth Solutions NW LLC
 Geotechnical Engineering, Construction
 Observation/Testing and Environmental Services

Vicinity Map
 Sunset Pointe
 Puyallup, Washington

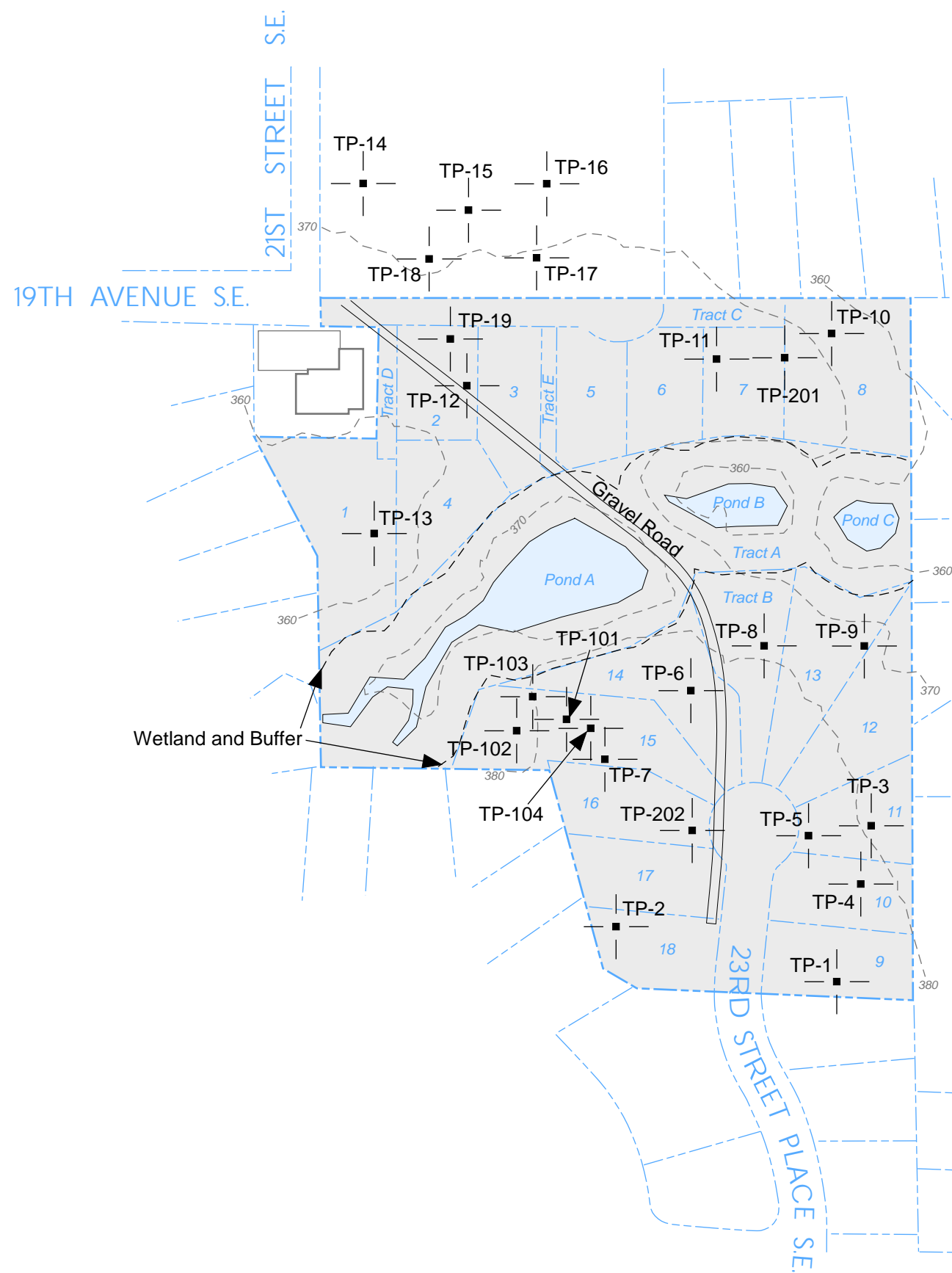
Drwn. CAM	Date 04/05/2023	Proj. No. 5559
Checked CGH	Date April 2023	Plate 1



LEGEND

- TP-201 | Approximate Location of ESNW Test Pit, Proj. No. ES-5559.03, Jan. 2020
- TP-101 | Approximate Location of ESNW Test Pit, Proj. No. ES-5559, May 2019
- TP-1 | Approximate Location of ESNW Test Pit, Proj. No. ES-5559, Oct. 2017
-  Subject Site
-  Existing Building
-  Proposed Lot Number

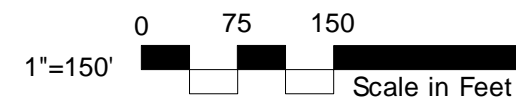
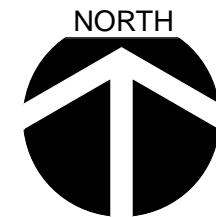

NOTE: The graphics shown on this plate are not intended for design purposes or precise scale measurements, but only to illustrate the approximate test locations relative to the approximate locations of existing and / or proposed site features. The information illustrated is largely based on data provided by the client at the time of our study. ESNW cannot be responsible for subsequent design changes or interpretation of the data by others.

NOTE: This plate may contain areas of color. ESNW cannot be responsible for any subsequent misinterpretation of the information resulting from black & white reproductions of this plate.



Drwn. By
CAM

Checked By
CGH

Date
05/26/2023

Proj. No.
5559

Plate
2

SCHEMATIC ONLY - NOT TO SCALE
NOT A CONSTRUCTION DRAWING

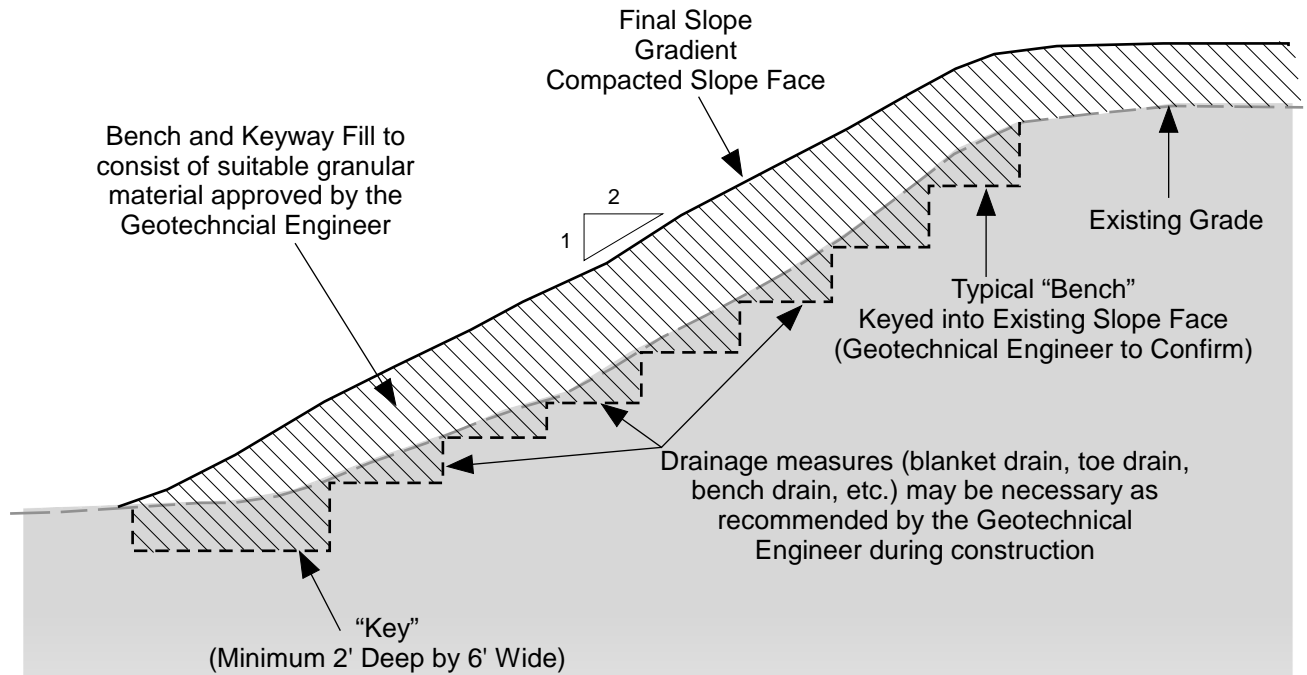

NOTES:

- Slope should be stripped of topsoil and unsuitable materials prior to excavating Keyway or benches.
- Benches will typically be equal to a bulldozer blade width of approximately 8 feet but shall be at least 4 feet.
- Final slope gradient should be 2H : 1V.
- Final slope face should be densified by over-building with compacted fill and trimming back to shape or by compaction with a bulldozer or vibratory drum roller.
- Planting or hydroseeding slope face with a rapid growth deep-rooted vegetative mat will reduce erosion potential of slope area.
- Use of pegged-in-place jute matting or geotechnical fabric will help maintain the seed and mulch in place until the root system has an opportunity to germinate.
- Structural fill should be placed in thin loose lifts not exceeding 12 inches in thickness. Each lift should be compacted to no less than the degree specified in the "Site Preparation and Earthwork" section of this report. No additional lift should be placed until compaction is achieved.



Earth Solutions NW_{LLC}

Geotechnical Engineering, Construction
Observation/Testing and Environmental Services

Slope Fill Detail
Sunset Pointe
Puyallup, Washington

Drwn. MRS	Date 10/09/2018	Proj. No. 5559
Checked CGH	Date Oct. 2018	Plate 3

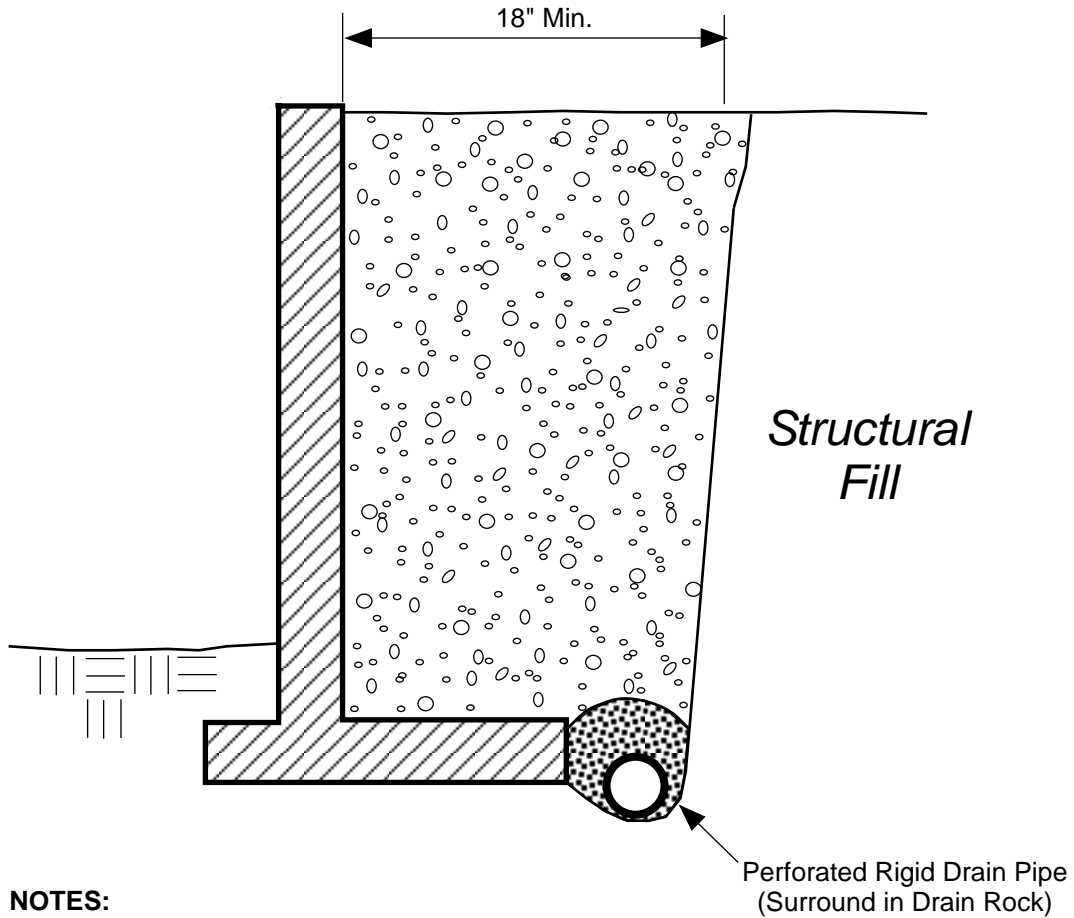

NOTES:

- Free-draining Backfill should consist of soil having less than 5 percent fines. Percent passing No. 4 sieve should be 25 to 75 percent.
- Sheet Drain may be feasible in lieu of Free-draining Backfill, per ESNW recommendations.
- Drain Pipe should consist of perforated, rigid PVC Pipe surrounded with 1-inch Drain Rock.

SCHMATIC ONLY - NOT TO SCALE
NOT A CONSTRUCTION DRAWING

LEGEND:

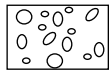

Free-draining Structural Backfill

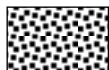

1-inch Drain Rock

		Earth Solutions NW_{LLC} Geotechnical Engineering, Construction Observation/Testing and Environmental Services
Retaining Wall Drainage Detail Sunset Pointe Puyallup, Washington		
Drwn. MRS	Date 10/09/2018	Proj. No. 5559
Checked CGH	Date Oct. 2018	Plate 4

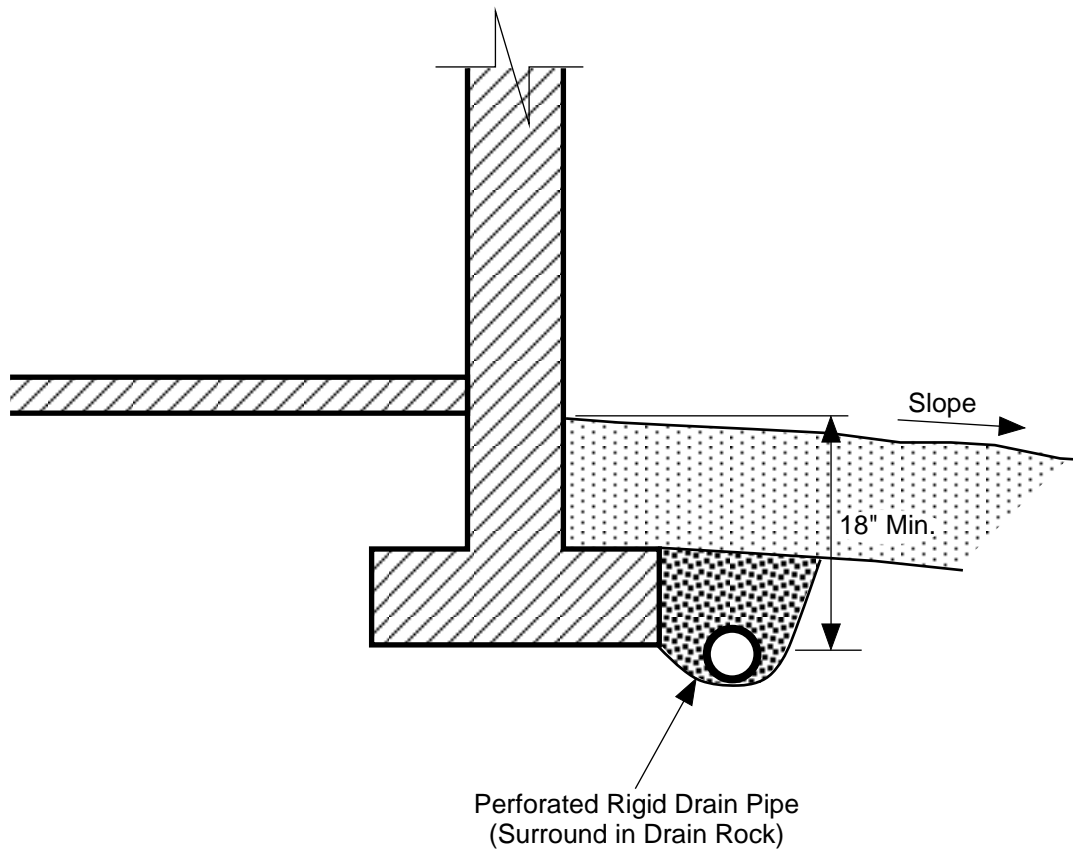

NOTES:

- Do NOT tie roof downspouts to Footing Drain.
- Surface Seal to consist of 12" of less permeable, suitable soil. Slope away from building.

SCHEMATIC ONLY - NOT TO SCALE
NOT A CONSTRUCTION DRAWING

LEGEND:

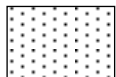

Surface Seal: native soil or other low-permeability material.

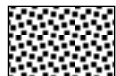

1-inch Drain Rock

	Earth Solutions NW_{LLC} Geotechnical Engineering, Construction Observation/Testing and Environmental Services	
	Footing Drain Detail Sunset Pointe Puyallup, Washington	
Drwn. MRS	Date 10/09/2018	Proj. No. 5559
Checked CGH	Date Oct. 2018	Plate 5

Appendix A

Subsurface Exploration Test Pit Logs

ES-5559

Subsurface conditions at the subject site were explored by an ESNW representative on October 24, 2017, May 15, 2019, and January 22, 2020. A total of 25 test pits were excavated at accessible areas of the site using an operator and trackhoe retained by ESNW. The approximate locations of the test pits are illustrated on Plate 2 of this study. The test pits logs are provided in this Appendix. The test pits were excavated to a maximum depth of approximately 18 feet bgs.

The final logs represent the interpretations of the field logs and the results of laboratory analyses. The stratification lines on the logs represent the approximate boundaries between soil types. In actuality, the transitions may be more gradual.

Coarse-Grained Soils - More Than 50% Retained on No. 200 Sieve		Moisture Content		Symbols	
Gravels - More Than 50% of Coarse Fraction Retained on No. 4 Sieve		GW	Well-graded gravel with or without sand, little to no fines	Dry - Absence of moisture, dusty, dry to the touch	
		GP	Poorly graded gravel with or without sand, little to no fines	Damp - Perceptible moisture, likely below optimum MC	
		GM	Silty gravel with or without sand	Moist - Damp but no visible water, likely at/near optimum MC	
		GC	Clayey gravel with or without sand	Wet - Water visible but not free draining, likely above optimum MC	
Sands - 50% or More of Coarse Fraction Passes No. 4 Sieve		SW	Well-graded sand with or without gravel, little to no fines	Saturated/Water Bearing - Visible free water, typically below groundwater table	
		SP	Poorly graded sand with or without gravel, little to no fines		
		SM	Silty sand with or without gravel		
		SC	Clayey sand with or without gravel		
Terms Describing Relative Density and Consistency					
Coarse-Grained Soils:		Test Symbols & Units			
Density	SPT blows/foot	Fines = Fines Content (%)			
Very Loose	< 4	MC = Moisture Content (%)			
Loose	4 to 9	DD = Dry Density (pcf)			
Medium Dense	10 to 29	Str = Shear Strength (tsf)			
Dense	30 to 49	PID = Photoionization Detector (ppm)			
Very Dense	≥ 50	OC = Organic Content (%)			
Fine-Grained Soils:		CEC = Cation Exchange Capacity (meq/100 g)			
Consistency	SPT blows/foot	LL = Liquid Limit (%)			
Very Soft	< 2	PL = Plastic Limit (%)			
Soft	2 to 3	PI = Plasticity Index (%)			
Medium Stiff	4 to 7				
Stiff	8 to 14				
Very Stiff	15 to 29				
Hard	≥ 30				
Fine-Grained Soils - 50% or More Passes No. 200 Sieve		Component Definitions			
Silt and Clays Liquid Limit Less Than 50		ML	Silt with or without sand or gravel; sandy or gravelly silt	<u>Descriptive Term</u>	<u>Size Range and Sieve Number</u>
		CL	Clay of low to medium plasticity; lean clay with or without sand or gravel; sandy or gravelly lean clay	Boulders	Larger than 12"
		OL	Organic clay or silt of low plasticity	Cobbles	3" to 12"
		Silt and Clays Liquid Limit 50 or More		MH	Elastic silt with or without sand or gravel; sandy or gravelly elastic silt
CH	Clay of high plasticity; fat clay with or without sand or gravel; sandy or gravelly fat clay			Coarse Gravel	3" to 3/4"
OH	Organic clay or silt of medium to high plasticity			Fine Gravel	3/4" to No. 4 (4.75 mm)
Highly Organic Soils		PT	Peat, muck, and other highly organic soils	Sand	No. 4 (4.75 mm) to No. 200 (0.075 mm)
				Coarse Sand	No. 4 (4.75 mm) to No. 10 (2.00 mm)
Fill		FILL	Made Ground	Medium Sand	No. 10 (2.00 mm) to No. 40 (0.425 mm)
				Fine Sand	No. 40 (0.425 mm) to No. 200 (0.075 mm)
		Modifier Definitions			
		<u>Percentage by Weight (Approx.)</u>	<u>Modifier</u>		
		< 5	Trace (sand, silt, clay, gravel)		
		5 to 14	Slightly (sandy, silty, clayey, gravelly)		
		15 to 29	Sandy, silty, clayey, gravelly		
		> 30	Very (sandy, silty, clayey, gravelly)		
Classifications of soils in this geotechnical report and as shown on the exploration logs are based on visual field and/or laboratory observations, which include density/consistency, moisture condition, grain size, and plasticity estimates, and should not be construed to imply field or laboratory testing unless presented herein. Visual-manual and/or laboratory classification methods of ASTM D2487 and D2488 were used as an identification guide for the Unified Soil Classification System.					



Earth Solutions NW LLC

Geotechnical Engineering, Construction
Observation/Testing and Environmental Services

EXPLORATION LOG KEY



Earth Solutions NW, LLC
 15365 N.E. 90th Street, Suite 100
 Redmond, Washington 98052
 Telephone: 425-449-4704
 Fax: 425-449-4711

TEST PIT NUMBER TP-201

PROJECT NUMBER ES-5559.03 PROJECT NAME Sunset Pointe
 DATE STARTED 1/22/20 COMPLETED 1/22/20 GROUND ELEVATION 374 ft
 EXCAVATION CONTRACTOR NW Excavating LATITUDE _____ LONGITUDE _____
 LOGGED BY CGH CHECKED BY SSR GROUND WATER LEVEL:
 NOTES Depth of Topsoil & Sod 6": grass AT TIME OF EXCAVATION _____
 SURFACE CONDITIONS _____ AFTER EXCAVATION _____

DEPTH (ft)	SAMPLE TYPE NUMBER	TESTS	U.S.C.S.	GRAPHIC LOG	MATERIAL DESCRIPTION	
0			TPSL		Dark brown TOPSOIL, root intrusions to 1'	373.5
		MC = 20.7	ML		Tan SILT, medium dense, moist to wet -mottled texture	
		MC = 32.6 Fines = 88.9			[USDA Classification: LOAM]	369.5
5		MC = 15.1	SP		Gray poorly graded SAND, dense, moist to wet	
		MC = 30.7	ML		-heavy iron oxide staining at contact, light groundwater seepage at 6'	368.0
		MC = 30.5 Fines = 78.7			Gray SILT with sand, dense, moist to wet -minor iron oxide staining throughout [USDA Classification: slightly gravelly LOAM]	366.0
Test pit terminated at 8.0 feet below existing grade. Groundwater seepage encountered at 6.0 feet during excavation. No caving observed.						



Earth Solutions NW, LLC
 15365 N.E. 90th Street, Suite 100
 Redmond, Washington 98052
 Telephone: 425-449-4704
 Fax: 425-449-4711

TEST PIT NUMBER TP-202

PROJECT NUMBER ES-5559.03 PROJECT NAME Sunset Pointe
 DATE STARTED 1/22/20 COMPLETED 1/22/20 GROUND ELEVATION 388 ft
 EXCAVATION CONTRACTOR NW Excavating LATITUDE _____ LONGITUDE _____
 LOGGED BY CGH CHECKED BY SSR GROUND WATER LEVEL:
 NOTES Depth of Topsoil & Sod 6": grass AT TIME OF EXCAVATION _____
 SURFACE CONDITIONS _____ AFTER EXCAVATION _____

DEPTH (ft)	SAMPLE TYPE NUMBER	TESTS	U.S.C.S.	GRAPHIC LOG	MATERIAL DESCRIPTION	
0						
		MC = 31.9 MC = 19.4 Fines = 58.7 MC = 31.8 MC = 13.3 Fines = 39.9	TPSL		Dark brown TOPSOIL, root intrusions to 6"	387.5
			FILL		Crushed rock (Fill) -light perched groundwater seepage	386.5
			SM		Tan silty SAND, medium dense, moist ~<8" sand lens	385.3
			ML		Tan sandy SILT, dense, moist -becomes gray	
			SM		Gray silty SAND, dense, moist -light iron oxide staining	
5					-increased sand content [USDA Classification: slightly gravelly fine sandy LOAM]	380.0
					Test pit terminated at 8.0 feet below existing grade. Groundwater seepage encountered at 1.0 foot during excavation. No caving observed.	



Earth Solutions NW, LLC
 15365 N.E. 90th Street, Suite 100
 Redmond, Washington 98052
 Telephone: 425-449-4704
 Fax: 425-449-4711

TEST PIT NUMBER TP-101

PROJECT NUMBER ES-5559 PROJECT NAME Sunset Pointe
 DATE STARTED 5/15/19 COMPLETED 5/19/19 GROUND ELEVATION 383 ft
 EXCAVATION CONTRACTOR NW Excavating LATITUDE _____ LONGITUDE _____
 LOGGED BY CGH CHECKED BY SSR GROUND WATER LEVEL:
 NOTES Depth of Topsoil & Sod 12": heavy bramble ∇ AT TIME OF EXCAVATION _____
 SURFACE CONDITIONS _____ AFTER EXCAVATION _____

DEPTH (ft)	SAMPLE TYPE NUMBER	TESTS	U.S.C.S.	GRAPHIC LOG	MATERIAL DESCRIPTION	
0						
			TPSL		Dark brown TOPSOIL, root intrusions to 12"	
				1.0		382.0
		MC = 13.8	SM		Gray silty SAND with gravel, dense, moist (Fill)	
5		MC = 20.0		5.5	-sand lens ~12" thick	377.5
			ML		Gray SILT, medium dense, moist (Fill)	
10		MC = 27.3 Fines = 90.0			-becomes brown, increased fines [USDA Classification: slightly gravelly LOAM]	
			ML		Tan SILT, medium dense, wet [USDA Classification: LOAM]	370.0
15		MC = 31.9 Fines = 95.8		15.0		368.0
		MC = 35.3	SM		Tan silty SAND, medium dense, wet to saturated -minor iron oxide staining	
				18.0	-sand lens 6"- 12" thick	365.0
		MC = 28.5			Test pit terminated at 18.0 feet below existing grade. No groundwater encountered during excavation. No caving observed.	

GENERAL BH / TP / WELL - 5559.GPJ - GINT US.GDT - 4/5/23



Earth Solutions NW, LLC
 15365 N.E. 90th Street, Suite 100
 Redmond, Washington 98052
 Telephone: 425-449-4704
 Fax: 425-449-4711

TEST PIT NUMBER TP-102

PROJECT NUMBER ES-5559 PROJECT NAME Sunset Pointe
 DATE STARTED 5/15/19 COMPLETED 5/15/19 GROUND ELEVATION 376 ft
 EXCAVATION CONTRACTOR NW Excavating LATITUDE _____ LONGITUDE _____
 LOGGED BY CGH CHECKED BY SSR GROUND WATER LEVEL:
 NOTES Depth of Topsoil & Sod 12": heavy bramble AT TIME OF EXCAVATION _____
 SURFACE CONDITIONS _____ AFTER EXCAVATION _____

DEPTH (ft)	SAMPLE TYPE NUMBER	TESTS	U.S.C.S.	GRAPHIC LOG	MATERIAL DESCRIPTION	
0						
			TPSL		Dark brown TOPSOIL, root intrusions to 2.25'	375.0
			SM		Brown silty SAND, loose, moist	373.5
5		MC = 25.4 Fines = 98.3			Gray SILT, dense, moist [USDA Classification: LOAM] -heavy iron oxide staining	
		MC = 32.0 Fines = 92.5	ML		-becomes brown, wet [USDA Classification: LOAM]	
					-becomes wet to saturated	
		MC = 35.2				366.5



Test pit terminated at 9.5 feet below existing grade. No groundwater encountered during excavation. No caving observed.



Earth Solutions NW, LLC
 15365 N.E. 90th Street, Suite 100
 Redmond, Washington 98052
 Telephone: 425-449-4704
 Fax: 425-449-4711

TEST PIT NUMBER TP-103

PROJECT NUMBER ES-5559 PROJECT NAME Sunset Pointe
 DATE STARTED 5/15/19 COMPLETED 5/15/19 GROUND ELEVATION 384 ft
 EXCAVATION CONTRACTOR NW Excavating LATITUDE _____ LONGITUDE _____
 LOGGED BY CGH CHECKED BY SSR GROUND WATER LEVEL:
 NOTES Depth of Topsoil & Sod 8": heavy bush AT TIME OF EXCAVATION _____
 SURFACE CONDITIONS _____ AFTER EXCAVATION _____

DEPTH (ft)	SAMPLE TYPE NUMBER	TESTS	U.S.C.S.	GRAPHIC LOG	MATERIAL DESCRIPTION	
0						
			TPSL		Dark brown TOPSOIL, root intrusions to 6.25' (Fill)	383.4
					Gray silty SAND with gravel, medium dense to dense, moist (Fill)	
		MC = 11.3			-asphalt debris	
5			SM			
		MC = 10.4			-increased sand content	
		MC = 11.7			-erratic silt interbeds	
10						
		MC = 20.2				373.0

Test pit terminated at 11.0 feet below existing grade. No groundwater encountered during excavation. No caving observed.



Earth Solutions NW, LLC
 15365 N.E. 90th Street, Suite 100
 Redmond, Washington 98052
 Telephone: 425-449-4704
 Fax: 425-449-4711

TEST PIT NUMBER TP-104

PROJECT NUMBER ES-5559 PROJECT NAME Sunset Pointe
 DATE STARTED 5/15/19 COMPLETED 5/15/19 GROUND ELEVATION 383 ft
 EXCAVATION CONTRACTOR NW Excavating LATITUDE _____ LONGITUDE _____
 LOGGED BY CGH CHECKED BY SSR GROUND WATER LEVEL:
 NOTES Depth of Topsoil & Sod 8": grass AT TIME OF EXCAVATION _____
 SURFACE CONDITIONS _____ AFTER EXCAVATION _____



DEPTH (ft)	SAMPLE TYPE NUMBER	TESTS	U.S.C.S.	GRAPHIC LOG	MATERIAL DESCRIPTION	
0						
			TPSL		Dark brown TOPSOIL, root intrusions to 12"	382.4
		MC = 19.9	SM		Gray silty SAND with gravel, medium dense to dense, moist -becomes brown -becomes gray	
5		MC = 23.5			-heavy iron oxide staining	378.0
			ML		Gray SILT, loose, moist to wet -becomes brown, wet	
10		MC = 29.8 Fines = 93.5			[USDA Classification: LOAM]	372.0

Test pit terminated at 11.0 feet below existing grade. No groundwater encountered during excavation. No caving observed.



Earth Solutions NW, LLC
 15365 N.E. 90th Street, Suite 100
 Redmond, Washington 98052
 Telephone: 425-449-4704
 Fax: 425-449-4711

PROJECT NUMBER ES-5559 PROJECT NAME Sunset Pointe
 DATE STARTED 10/24/17 COMPLETED 10/24/17 GROUND ELEVATION _____
 EXCAVATION CONTRACTOR NW Excavating LATITUDE _____ LONGITUDE _____
 LOGGED BY CGH CHECKED BY HTW GROUND WATER LEVEL:
 NOTES Depth of Topsoil & Sod 1"- 3": grass AT TIME OF EXCAVATION _____
 SURFACE CONDITIONS _____ AFTER EXCAVATION _____

DEPTH (ft)	SAMPLE TYPE NUMBER	TESTS	U.S.C.S.	GRAPHIC LOG	MATERIAL DESCRIPTION
0			Rock		0.5 Crushed Rock (Fill)
			ML		1.0 Brown SILT, loose, moist
		MC = 7.4 Fines = 6.2	SP-SM		Brown poorly graded SAND with silt, medium dense, moist
5					[USDA Classification: slightly gravelly SAND]
		MC = 4.4			-increased gravel content -becomes medium dense to dense
		MC = 7.4			-increased cobbles

Test pit terminated at 9.0 feet below existing grade. No groundwater encountered during excavation. No caving observed.



Earth Solutions NW, LLC
 15365 N.E. 90th Street, Suite 100
 Redmond, Washington 98052
 Telephone: 425-449-4704
 Fax: 425-449-4711

TEST PIT NUMBER TP-2

PROJECT NUMBER ES-5559 PROJECT NAME Sunset Pointe
 DATE STARTED 10/24/17 COMPLETED 10/24/17 GROUND ELEVATION _____
 EXCAVATION CONTRACTOR NW Excavating LATITUDE _____ LONGITUDE _____
 LOGGED BY CGH CHECKED BY HTW GROUND WATER LEVEL:
 NOTES Depth of Topsoil & Sod 4": brush AT TIME OF EXCAVATION _____
 SURFACE CONDITIONS _____ AFTER EXCAVATION _____

DEPTH (ft)	SAMPLE TYPE NUMBER	TESTS	U.S.C.S.	GRAPHIC LOG	MATERIAL DESCRIPTION
0			TPSL		0.3 Dark brown TOPSOIL (Fill), root intrusions to 7'
			Fill		1.0 Clean washed ROCK (Fill)
		MC = 21.6	ML		Brown/tan sandy SILT, medium dense, moist -light iron oxide staining 2'- 4'
5			SP		5.0 Gray poorly graded SAND, medium dense to dense, moist
		MC = 9.5	ML		6.5 Tan sandy SILT, dense, moist
			SP		8.0 Gray poorly graded SAND with gravel, dense, moist
		MC = 4.8			9.0 -caving caused by excavation activities

Test pit terminated at 9.0 feet below existing grade. No groundwater seepage encountered during excavation. Caving observed from 6.0 to 6.5 feet and 8.0 feet to BOH.



Earth Solutions NW, LLC
 15365 N.E. 90th Street, Suite 100
 Redmond, Washington 98052
 Telephone: 425-449-4704
 Fax: 425-449-4711

TEST PIT NUMBER TP-3

PAGE 1 OF 1

PROJECT NUMBER ES-5559 PROJECT NAME Sunset Pointe
 DATE STARTED 10/24/17 COMPLETED 10/24/17 GROUND ELEVATION _____
 EXCAVATION CONTRACTOR NW Excavating LATITUDE _____ LONGITUDE _____
 LOGGED BY CGH CHECKED BY HTW GROUND WATER LEVEL:
 NOTES Depth of Topsoil & Sod 18": brush AT TIME OF EXCAVATION _____
 SURFACE CONDITIONS _____ AFTER EXCAVATION _____

DEPTH (ft)	SAMPLE TYPE NUMBER	TESTS	U.S.C.S.	GRAPHIC LOG	MATERIAL DESCRIPTION
0					
			TPSL		Dark brown TOPSOIL (Fill), intrusions to 7'
		MC = 8.9			Gray silty SAND with gravel, medium dense, moist (Fill)
5		MC = 8.1 Fines = 15.9	SM		-clean washed rock ~4" thick -becomes brown dense [USDA Classification: very gravelly loamy SAND]
					7.0
			ML		Gray SILT with sand, medium dense, moist (Fill)
		MC = 19.2			9.0



Test pit terminated at 9.0 feet below existing grade. No groundwater encountered during excavation. No caving observed.



Earth Solutions NW, LLC
 15365 N.E. 90th Street, Suite 100
 Redmond, Washington 98052
 Telephone: 425-449-4704
 Fax: 425-449-4711

TEST PIT NUMBER TP-4

PROJECT NUMBER ES-5559 PROJECT NAME Sunset Pointe
 DATE STARTED 10/24/17 COMPLETED 10/24/17 GROUND ELEVATION _____
 EXCAVATION CONTRACTOR NW Excavating LATITUDE _____ LONGITUDE _____
 LOGGED BY CGH CHECKED BY HTW GROUND WATER LEVEL: _____
 NOTES Depth of Topsoil & Sod 2": brush AT TIME OF EXCAVATION _____
 SURFACE CONDITIONS _____ AFTER EXCAVATION _____

DEPTH (ft)	SAMPLE TYPE NUMBER	TESTS	U.S.C.S.	GRAPHIC LOG	MATERIAL DESCRIPTION
0					
5		MC = 12.3	SM		Brown silty SAND, loose to medium dense, moist (Fill) -root intrusions to 9' -heavy perched groundwater seepage
10		MC = 19.3	ML		Gray SILT with sand, loose to medium dense, wet (Fill) -trace organics -light iron oxide staining
15		MC = 22.1	ML		Brown sandy SILT, dense, moist -light iron oxide staining
		MC = 27.4			

Test pit terminated at 15.0 feet below existing grade. Groundwater encountered seepage encountered at 4.0 feet during excavation. Caving observed from 0.0 to 9.0 feet.



Earth Solutions NW, LLC
 15365 N.E. 90th Street, Suite 100
 Redmond, Washington 98052
 Telephone: 425-449-4704
 Fax: 425-449-4711

PROJECT NUMBER ES-5559 PROJECT NAME Sunset Pointe
 DATE STARTED 10/24/17 COMPLETED 10/24/17 GROUND ELEVATION _____
 EXCAVATION CONTRACTOR NW Excavating LATITUDE _____ LONGITUDE _____
 LOGGED BY CGH CHECKED BY HTW GROUND WATER LEVEL:
 NOTES Depth of Topsoil & Sod 12": brush AT TIME OF EXCAVATION _____
 SURFACE CONDITIONS _____ AFTER EXCAVATION _____

DEPTH (ft)	SAMPLE TYPE NUMBER	TESTS	U.S.C.S.	GRAPHIC LOG	MATERIAL DESCRIPTION
0					
			TPSL		Dark brown TOPSOIL, root intrusions to 3'
		MC = 7.2			Brown silty SAND, medium dense, moist -becomes tan, damp to moist
5		MC = 20.9	SM		-becomes dense -light iron oxide staining
		MC = 12.4			-becomes gray, very dense -moderate cementation, light iron oxide staining

Test pit terminated at 9.5 feet below existing grade. No groundwater encountered during excavation. No caving observed.





Earth Solutions NW, LLC
 15365 N.E. 90th Street, Suite 100
 Redmond, Washington 98052
 Telephone: 425-449-4704
 Fax: 425-449-4711

TEST PIT NUMBER TP-6

PAGE 1 OF 1

PROJECT NUMBER ES-5559 PROJECT NAME Sunset Pointe
 DATE STARTED 10/24/17 COMPLETED 10/24/17 GROUND ELEVATION _____
 EXCAVATION CONTRACTOR NW Excavating LATITUDE _____ LONGITUDE _____
 LOGGED BY CGH CHECKED BY HTW GROUND WATER LEVEL:
 NOTES Depth of Topsoil & Sod 2"- 4": grass AT TIME OF EXCAVATION _____
 SURFACE CONDITIONS _____ AFTER EXCAVATION _____

DEPTH (ft)	SAMPLE TYPE NUMBER	TESTS	U.S.C.S.	GRAPHIC LOG	MATERIAL DESCRIPTION
0					
			SM		Brown silty SAND, medium dense, moist (Fill) -root intrusions to 7'
				2.0	
				2.5	Relic TOPSOIL Horizon
		MC = 20.5	ML		Brown sandy SILT, medium dense, moist (Fill) -minor brick debris -becomes gray
5					
		MC = 10.0	SP		Brown poorly graded SAND, dense, moist -light iron oxide staining
10					
		MC = 31.7			-becomes wet to saturated
12.0					

Test pit terminated at 12.0 feet below existing grade. No groundwater encountered during excavation. No caving observed.



Earth Solutions NW, LLC
 15365 N.E. 90th Street, Suite 100
 Redmond, Washington 98052
 Telephone: 425-449-4704
 Fax: 425-449-4711

PROJECT NUMBER ES-5559 PROJECT NAME Sunset Pointe
 DATE STARTED 10/24/17 COMPLETED 10/24/17 GROUND ELEVATION _____
 EXCAVATION CONTRACTOR NW Excavating LATITUDE _____ LONGITUDE _____
 LOGGED BY CGH CHECKED BY HTW GROUND WATER LEVEL:
 NOTES Depth of Topsoil & Sod 6"- 8": brush AT TIME OF EXCAVATION _____
 SURFACE CONDITIONS _____ AFTER EXCAVATION _____

DEPTH (ft)	SAMPLE TYPE NUMBER	TESTS	U.S.C.S.	GRAPHIC LOG	MATERIAL DESCRIPTION
0			TPSL		Dark brown TOPSOIL, root intrusions to 7'
		MC = 9.5	SM		Brown silty SAND, loose to medium dense, moist -light to moderate iron staining -becomes gray, very dense
5					
		MC = 18.0			-becomes wet

Test pit terminated at 9.0 feet below existing grade. No groundwater encountered during excavation. No caving observed.



Earth Solutions NW, LLC
 15365 N.E. 90th Street, Suite 100
 Redmond, Washington 98052
 Telephone: 425-449-4704
 Fax: 425-449-4711

TEST PIT NUMBER TP-9

PROJECT NUMBER ES-5559 PROJECT NAME Sunset Pointe
 DATE STARTED 10/24/17 COMPLETED 10/24/17 GROUND ELEVATION _____
 EXCAVATION CONTRACTOR NW Excavating LATITUDE _____ LONGITUDE _____
 LOGGED BY CGH CHECKED BY HTW GROUND WATER LEVEL:
 NOTES Depth of Topsoil & Sod 4": grass AT TIME OF EXCAVATION _____
 SURFACE CONDITIONS _____ AFTER EXCAVATION _____

DEPTH (ft)	SAMPLE TYPE NUMBER	TESTS	U.S.C.S.	GRAPHIC LOG	MATERIAL DESCRIPTION	
0						
		MC = 21.7 Fines = 81.2	TPSL		0.5	Dark brown TOPSOIL, root intrusions to 3'
			ML			Brown SILT with sand, medium dense to dense, moist [USDA Classification: LOAM] -becomes gray -light iron oxide staining
5			SP		6.0 6.5	Gray poorly graded SAND, dense, moist

MC = 3.9



Test pit terminated at 6.5 feet below existing grade. No groundwater encountered during excavation. No caving observed.



Earth Solutions NW, LLC
 15365 N.E. 90th Street, Suite 100
 Redmond, Washington 98052
 Telephone: 425-449-4704
 Fax: 425-449-4711

TEST PIT NUMBER TP-10

PROJECT NUMBER ES-5559 PROJECT NAME Sunset Pointe
 DATE STARTED 10/24/17 COMPLETED 10/24/17 GROUND ELEVATION _____
 EXCAVATION CONTRACTOR NW Excavating LATITUDE _____ LONGITUDE _____
 LOGGED BY CGH CHECKED BY HTW GROUND WATER LEVEL:
 NOTES Depth of Topsoil & Sod 2": grass AT TIME OF EXCAVATION _____
 SURFACE CONDITIONS _____ AFTER EXCAVATION _____

DEPTH (ft)	SAMPLE TYPE NUMBER	TESTS	U.S.C.S.	GRAPHIC LOG	MATERIAL DESCRIPTION
0					
			SM		Gray silty SAND, medium dense, moist (Fill) -root intrusions to 3.5'
		MC = 12.4	TPSL		Relic TOPSOIL Horizon
					Brown silty SAND, medium dense, moist -becomes gray, dense
5		MC = 18.7	SM		
		MC = 8.9			

Test pit terminated at 9.0 feet below existing grade. No groundwater encountered during excavation. No caving observed.



Earth Solutions NW, LLC
 15365 N.E. 90th Street, Suite 100
 Redmond, Washington 98052
 Telephone: 425-449-4704
 Fax: 425-449-4711

TEST PIT NUMBER TP-11

PAGE 1 OF 1

PROJECT NUMBER ES-5559 PROJECT NAME Sunset Pointe
 DATE STARTED 10/24/17 COMPLETED 10/24/17 GROUND ELEVATION _____
 EXCAVATION CONTRACTOR NW Excavating LATITUDE _____ LONGITUDE _____
 LOGGED BY CGH CHECKED BY HTW GROUND WATER LEVEL:
 NOTES Depth of Topsoil & Sod 6": grass AT TIME OF EXCAVATION _____
 SURFACE CONDITIONS _____ AFTER EXCAVATION _____

DEPTH (ft)	SAMPLE TYPE NUMBER	TESTS	U.S.C.S.	GRAPHIC LOG	MATERIAL DESCRIPTION
0					
			TPSL		Dark brown TOPSOIL, root intrusions to 4'
		MC = 21.1			Tan silty SAND, medium dense, moist -moderate iron oxide staining to 4'
5		MC = 20.1	SM		-intermittent light iron oxide staining -becomes dense
10		MC = 16.0			

Test pit terminated at 10.0 feet below existing grade. No groundwater encountered during excavation. No caving observed.



Earth Solutions NW, LLC
 15365 N.E. 90th Street, Suite 100
 Redmond, Washington 98052
 Telephone: 425-449-4704
 Fax: 425-449-4711

TEST PIT NUMBER TP-12

PROJECT NUMBER ES-5559 PROJECT NAME Sunset Pointe
 DATE STARTED 10/24/17 COMPLETED 10/24/17 GROUND ELEVATION _____
 EXCAVATION CONTRACTOR NW Excavating LATITUDE _____ LONGITUDE _____
 LOGGED BY CGH CHECKED BY HTW GROUND WATER LEVEL:
 NOTES Depth of Topsoil & Sod 2": grass AT TIME OF EXCAVATION _____
 SURFACE CONDITIONS _____ AFTER EXCAVATION _____

DEPTH (ft)	SAMPLE TYPE NUMBER	TESTS	U.S.C.S.	GRAPHIC LOG	MATERIAL DESCRIPTION
0					
					Brown sandy SILT, medium dense, moist -root intrusions to 3'
		MC = 15.2 Fines = 60.2	ML		-becomes gray [USDA Classification: LOAM]
5					
		MC = 17.3			
				6.0	

Test pit terminated at 6.0 feet below existing grade. No groundwater encountered during excavation. No caving observed.



Earth Solutions NW, LLC
 15365 N.E. 90th Street, Suite 100
 Redmond, Washington 98052
 Telephone: 425-449-4704
 Fax: 425-449-4711

TEST PIT NUMBER TP-13

PROJECT NUMBER ES-5559 PROJECT NAME Sunset Pointe
 DATE STARTED 10/24/17 COMPLETED 10/24/17 GROUND ELEVATION _____
 EXCAVATION CONTRACTOR NW Excavating LATITUDE _____ LONGITUDE _____
 LOGGED BY CGH CHECKED BY HTW GROUND WATER LEVEL:
 NOTES Depth of Topsoil & Sod 4": grass AT TIME OF EXCAVATION _____
 SURFACE CONDITIONS _____ AFTER EXCAVATION _____

DEPTH (ft)	SAMPLE TYPE NUMBER	TESTS	U.S.C.S.	GRAPHIC LOG	MATERIAL DESCRIPTION
0					Brown sandy SILT, loose to medium dense, moist
5		MC = 27.3	ML		-becomes gray
		MC = 23.9			
10		MC = 16.0	SP	9.5 10.0	Gray poorly graded SAND with gravel, dense, wet

Test pit terminated at 10.0 feet below existing grade. No groundwater encountered during excavation. No caving observed.



Earth Solutions NW, LLC
 15365 N.E. 90th Street, Suite 100
 Redmond, Washington 98052
 Telephone: 425-449-4704
 Fax: 425-449-4711

TEST PIT NUMBER TP-14

PROJECT NUMBER ES-5559 PROJECT NAME Sunset Pointe
 DATE STARTED 10/24/17 COMPLETED 10/24/17 GROUND ELEVATION _____
 EXCAVATION CONTRACTOR NW Excavating LATITUDE _____ LONGITUDE _____
 LOGGED BY CGH CHECKED BY HTW GROUND WATER LEVEL:
 NOTES Depth of Topsoil & Sod 6"- 8": grass AT TIME OF EXCAVATION _____
 SURFACE CONDITIONS _____ AFTER EXCAVATION _____

DEPTH (ft)	SAMPLE TYPE NUMBER	TESTS	U.S.C.S.	GRAPHIC LOG	MATERIAL DESCRIPTION
0					
			TPSL		Dark brown TOPSOIL, root intrusions to 3'
		MC = 15.2	SM		Brown silty SAND, loose to medium dense, moist -becomes gray, medium dense -light iron oxide staining
5		MC = 7.1	SP		Gray poorly graded SAND, dense, moist
10		MC = 12.5	SM		Brown silty SAND, dense, moist
		MC = 9.0			

Test pit terminated at 12.0 feet below existing grade. No groundwater encountered during excavation. No caving observed.





Earth Solutions NW, LLC
 15365 N.E. 90th Street, Suite 100
 Redmond, Washington 98052
 Telephone: 425-449-4704
 Fax: 425-449-4711

TEST PIT NUMBER TP-15

PAGE 1 OF 1

PROJECT NUMBER ES-5559 PROJECT NAME Sunset Pointe
 DATE STARTED 10/24/17 COMPLETED 10/24/17 GROUND ELEVATION _____
 EXCAVATION CONTRACTOR NW Excavating LATITUDE _____ LONGITUDE _____
 LOGGED BY CGH CHECKED BY HTW GROUND WATER LEVEL:
 NOTES Surface Conditions: brush AT TIME OF EXCAVATION _____
 SURFACE CONDITIONS _____ AFTER EXCAVATION _____

DEPTH (ft)	SAMPLE TYPE NUMBER	TESTS	U.S.C.S.	GRAPHIC LOG	MATERIAL DESCRIPTION
0					
5		MC = 18.9	SM		Brown silty SAND, loose, moist (Fill) -trace to moderate organics throughout -root intrusions to 12'
10		MC = 91.3 Fines = 79.0			[USDA Classification: gravelly loamy coarse SAND] -becomes wet
15		MC = 28.6	ML		Gray sandy SILT, medium dense, moist
					Test pit terminated at 16.0 feet below existing grade. No groundwater encountered during excavation. No caving observed.

GENERAL BH / TP / WELL - 5559.GPJ - GINT US.GDT - 4/5/23



Earth Solutions NW, LLC
 15365 N.E. 90th Street, Suite 100
 Redmond, Washington 98052
 Telephone: 425-449-4704
 Fax: 425-449-4711

TEST PIT NUMBER TP-16

PROJECT NUMBER ES-5559 PROJECT NAME Sunset Pointe
 DATE STARTED 10/24/17 COMPLETED 10/24/17 GROUND ELEVATION _____
 EXCAVATION CONTRACTOR NW Excavating LATITUDE _____ LONGITUDE _____
 LOGGED BY CGH CHECKED BY HTW GROUND WATER LEVEL:
 NOTES Surface Conditions: brush AT TIME OF EXCAVATION _____
 SURFACE CONDITIONS _____ AFTER EXCAVATION _____

DEPTH (ft)	SAMPLE TYPE NUMBER	TESTS	U.S.C.S.	GRAPHIC LOG	MATERIAL DESCRIPTION
0					
		MC = 30.8	SM		Dark brown silty SAND, loose, wet -root intrusions to 3'
5		MC = 16.5			-becomes brown, medium dense, moist
		MC = 7.9			-becomes gray

6.0



Test pit terminated at 6.0 feet below existing grade. No groundwater encountered during excavation. No caving observed.



Earth Solutions NW, LLC
 15365 N.E. 90th Street, Suite 100
 Redmond, Washington 98052
 Telephone: 425-449-4704
 Fax: 425-449-4711

TEST PIT NUMBER TP-17

PROJECT NUMBER ES-5559 PROJECT NAME Sunset Pointe
 DATE STARTED 10/24/17 COMPLETED 10/24/17 GROUND ELEVATION _____
 EXCAVATION CONTRACTOR NW Excavating LATITUDE _____ LONGITUDE _____
 LOGGED BY CGH CHECKED BY HTW GROUND WATER LEVEL:
 NOTES Depth of Topsoil & Sod 4": brush AT TIME OF EXCAVATION _____
 SURFACE CONDITIONS _____ AFTER EXCAVATION _____

DEPTH (ft)	SAMPLE TYPE NUMBER	TESTS	U.S.C.S.	GRAPHIC LOG	MATERIAL DESCRIPTION
0					
5		MC = 24.1	SM		Brown silty SAND, loose, wet (Fill) -root intrusions to 7'
		MC = 6.3	SM		Tan silty SAND, medium dense, moist



Test pit terminated at 7.5 feet below existing grade. No groundwater encountered during excavation. No caving observed.



Earth Solutions NW, LLC
 15365 N.E. 90th Street, Suite 100
 Redmond, Washington 98052
 Telephone: 425-449-4704
 Fax: 425-449-4711

TEST PIT NUMBER TP-18

PROJECT NUMBER ES-5559 PROJECT NAME Sunset Pointe
 DATE STARTED 10/24/17 COMPLETED 10/24/17 GROUND ELEVATION _____
 EXCAVATION CONTRACTOR NW Excavating LATITUDE _____ LONGITUDE _____
 LOGGED BY CGH CHECKED BY HTW GROUND WATER LEVEL:
 NOTES Depth of Topsoil & Sod 2"- 3": brush AT TIME OF EXCAVATION _____
 SURFACE CONDITIONS _____ AFTER EXCAVATION _____

DEPTH (ft)	SAMPLE TYPE NUMBER	TESTS	U.S.C.S.	GRAPHIC LOG	MATERIAL DESCRIPTION
0					
		MC = 14.9	SM		Brown silty SAND, loose, moist (Fill) -root intrusions to 3'
5					-wire debris
		MC = 6.3	SM		Tan silty SAND, medium dense, moist

Test pit terminated at 6.0 feet below existing grade. No groundwater encountered during excavation. No caving observed.



Earth Solutions NW, LLC
 15365 N.E. 90th Street, Suite 100
 Redmond, Washington 98052
 Telephone: 425-449-4704
 Fax: 425-449-4711

TEST PIT NUMBER TP-19

PAGE 1 OF 1

PROJECT NUMBER ES-5559 PROJECT NAME Sunset Pointe
 DATE STARTED 10/24/17 COMPLETED 10/24/17 GROUND ELEVATION _____
 EXCAVATION CONTRACTOR NW Excavating LATITUDE _____ LONGITUDE _____
 LOGGED BY CGH CHECKED BY HTW GROUND WATER LEVEL:
 NOTES Depth of Topsoil & Sod 10": brush AT TIME OF EXCAVATION _____
 SURFACE CONDITIONS _____ AFTER EXCAVATION _____

DEPTH (ft)	SAMPLE TYPE NUMBER	TESTS	U.S.C.S.	GRAPHIC LOG	MATERIAL DESCRIPTION
0					
			TPSL		Dark brown TOPSOIL, root intrusions to 2'
		MC = 13.0		1.0	Gray silty SAND, medium dense, moist
			SM		-becomes dense
5		MC = 15.4		5.0	

Test pit terminated at 5.0 feet below existing grade. No groundwater encountered during excavation. No caving observed.

Appendix B
Laboratory Test Results
ES-5559



Earth Solutions NW, LLC
 15365 N.E. 90th Street, Suite 100
 Redmond, Washington 98052
 Telephone: 425-449-4704
 Fax: 425-449-4711

GRAIN SIZE DISTRIBUTION

PROJECT NUMBER ES-5559.03

PROJECT NAME Sunset Pointe

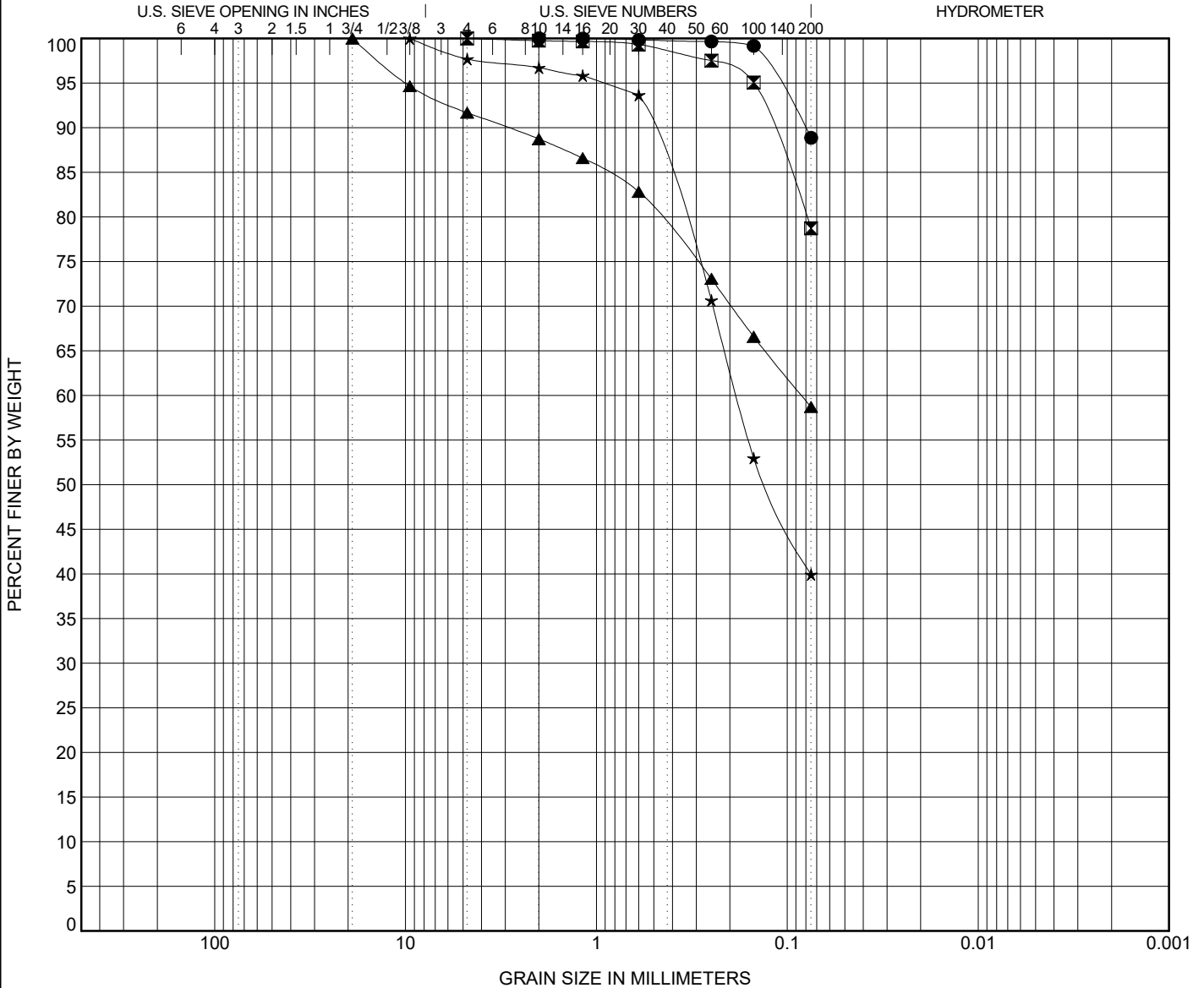



Earth Solutions NW
 1805 - 136th Place N.E., Suite 201
 Bellevue, Washington 98005
 Telephone: 425-449-4704
 Fax: 425-449-4711

GRAIN SIZE DISTRIBUTION

PROJECT NUMBER **ES-5559**

PROJECT NAME **Sunset Pointe**

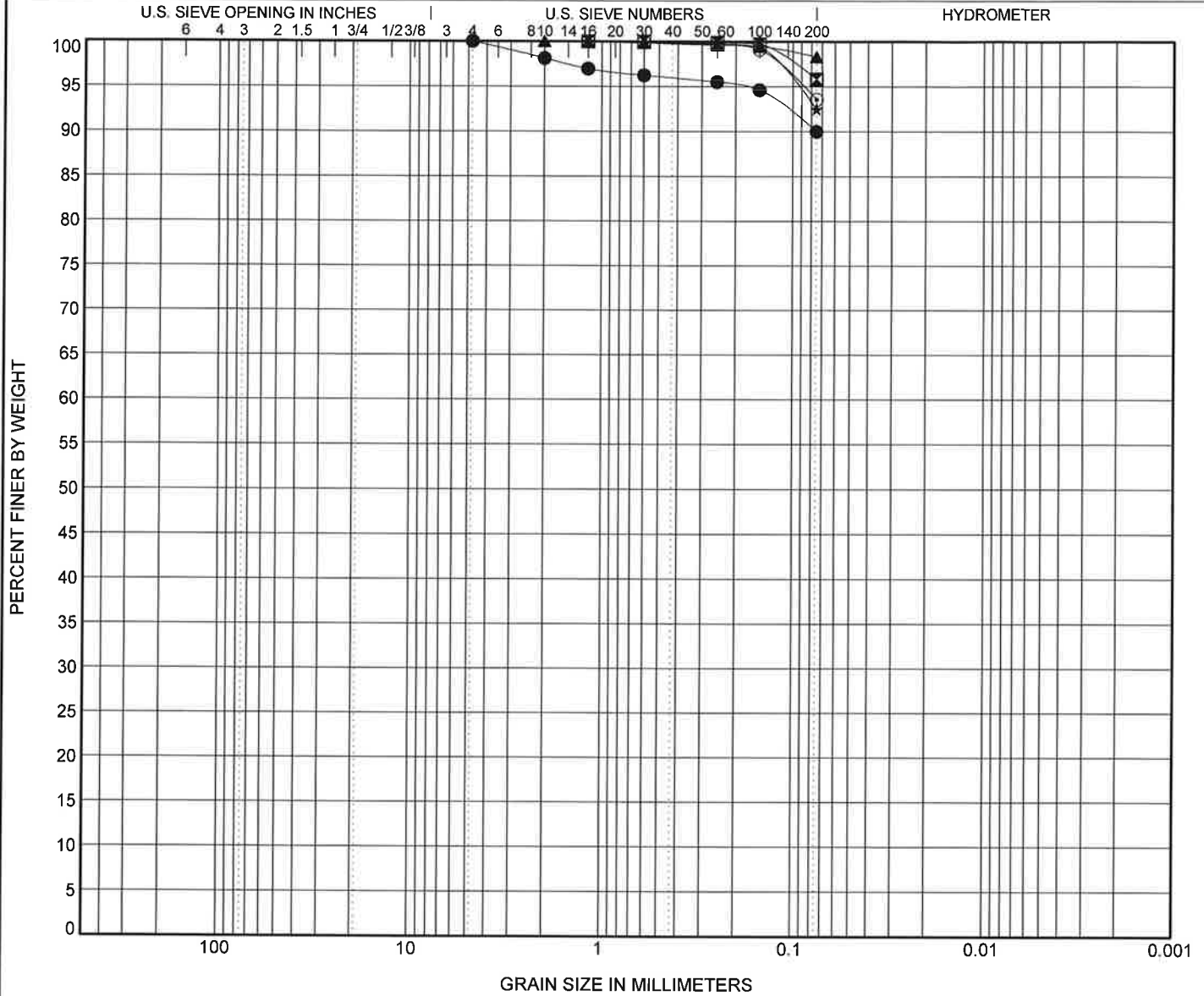

COBBLES	GRAVEL		SAND			SILT OR CLAY
	coarse	fine	coarse	medium	fine	

Specimen Identification	Classification					Cc	Cu
● TP-101 10.00ft.	USDA: Gray Slightly Gravelly Loam. USCS: ML.						
☒ TP-101 14.00ft.	USDA: Tan Loam. USCS: ML.						
▲ TP-102 3.00ft.	USDA: Gray Loam. USCS: ML.						
★ TP-102 6.00ft.	USDA Brown Loam. USCS: ML.						
◎ TP-104 11.00ft.	USDA: Brown Loam. USCS: ML.						

Specimen Identification	D100	D60	D30	D10	LL	PL	PI	%Silt	%Clay
● TP-101 10.0ft.	4.75							90.0	
☒ TP-101 14.0ft.	1.18							95.8	
▲ TP-102 3.0ft.	2							98.3	
★ TP-102 6.0ft.	1.18							92.5	
◎ TP-104 11.0ft.	1.18							93.5	

GRAIN SIZE USDA ES-5559 SUNSET POINTE.GPJ GINT US LAB GDT 6/24/19



Earth Solutions NW, LLC
 1805 - 136th PL N.E., Suite 201
 Bellevue, WA 98005
 Telephone: 425-449-4704
 Fax: 425-449-4711

GRAIN SIZE DISTRIBUTION

CLIENT Peter Chen

PROJECT NAME Sunset Pointe

PROJECT NUMBER ES-5559

PROJECT LOCATION Puyallup, Washington

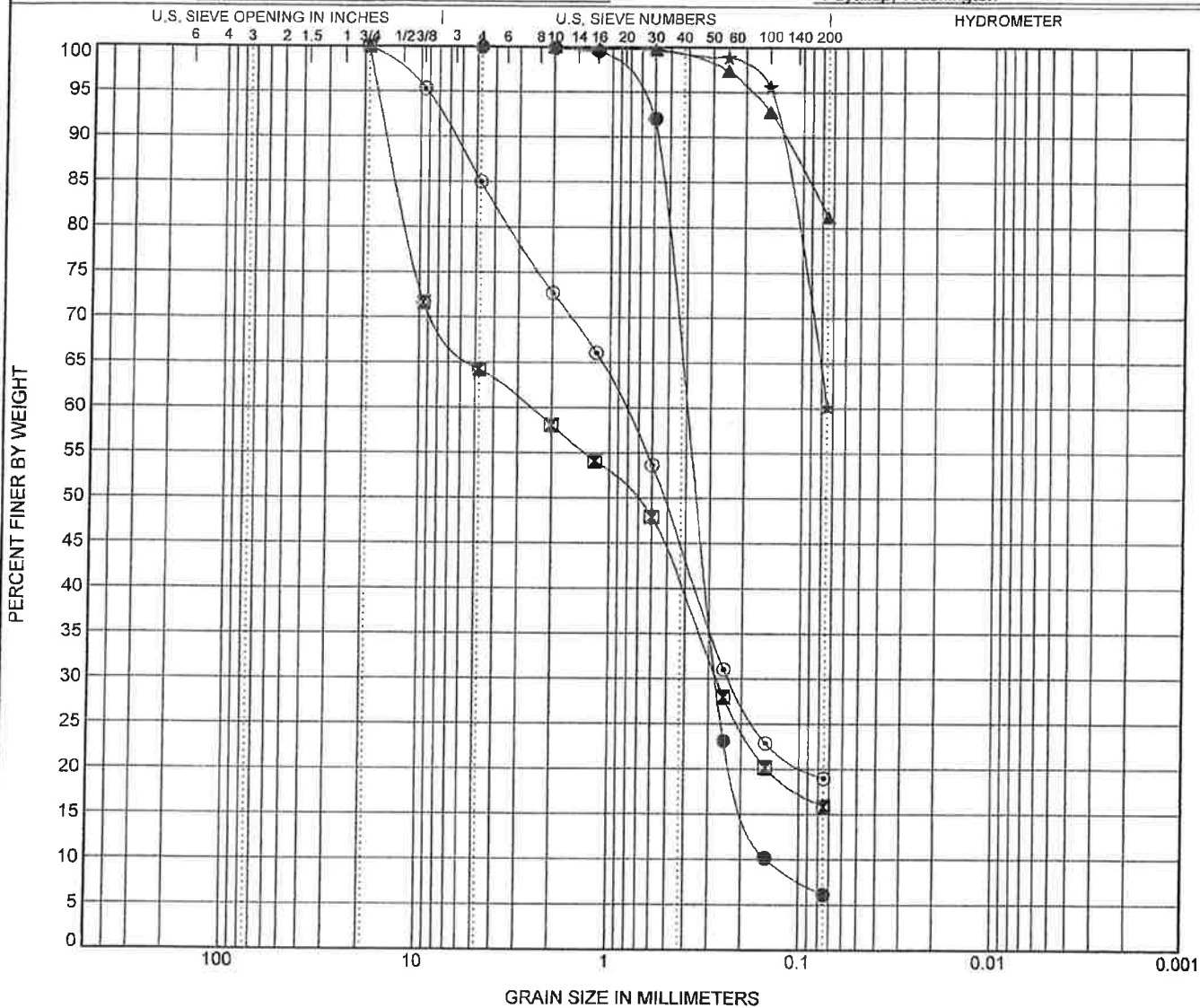

COBBLES	GRAVEL		SAND			SILT OR CLAY
	coarse	fine	coarse	medium	fine	

Specimen Identification	Classification	Cc	Cu						
● TP-01 3.00ft.	USDA: Brown Slightly Gravelly Sand. USCS: SP-SM.	1.28	2.74						
☒ TP-03 5.00ft.	USDA: Brown Very Gravelly Loamy Sand. USCS: SM with Gravel.								
▲ TP-09 2.50ft.	USDA: Gray Loam. USCS: ML with Sand.								
★ TP-12 4.00ft.	USDA: Brown Loam. USCS: Sandy ML.								
◎ TP-15 10.50ft.	USDA: Brown Gravelly Loamy Coarse Sand. USCS: SM with Gravel.								
Specimen Identification	D100	D60	D30	D10	LL	PL	PI	%Silt	%Clay
● TP-01 3.0ft.	4.75	0.399	0.273	0.146				6.2	
☒ TP-03 5.0ft.	19	2.638	0.273					15.9	
▲ TP-09 2.5ft.	2							81.2	
★ TP-12 4.0ft.	2							60.2	
◎ TP-15 10.5ft.	19	0.847	0.234					19.0	

GRAIN SIZE USDA ES-5559 SUNSET POINTE.GPJ GINT US LAB.GDT 11/10/17

Report Distribution

ES-5559

EMAIL ONLY

**Peter Chen
4709 Memory Lane West
University Place, Washington 98488**

EMAIL ONLY

**CES NW, Inc.
429 – 29th Street Northeast, Suite D
Puyallup, Washington 98372**

Attention: Fred Brown, P.E.